

ARMY TM 9-1025-211-34 MARINE CORPS TM 08198A-34/3

SUPERSEDES COPY DATED 15 July 1980

TECHNICAL MANUAL

DIRECT SUPPORT AND GENERAL SUPPORT MAINTENANCE MANUAL

FOR

HOWITZER, MEDIUM, TOWED:
155-MM, M198
(1025-01-026-6648) (EIC:3EL)

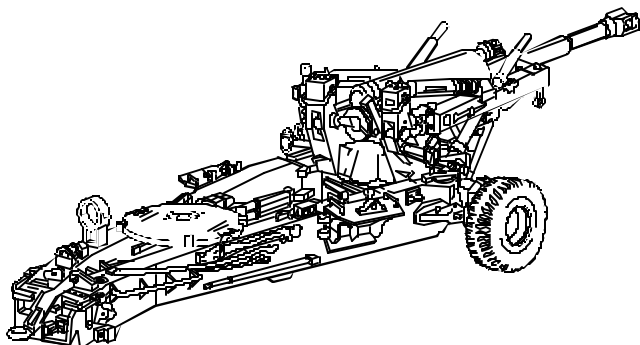

INTRODUCTION	PAGE 1-1
--------------	-------------

M199 CANNON MAINTENANCE INSTRUCTIONS	PAGE 2-23
--	--------------

M45 RECOIL MECHANISM MAINTENANCE INSTRUCTIONS	PAGE 2-58
---	--------------

M39 CARRIAGE MAINTENANCE INSTRUCTIONS	PAGE 2-138
---	---------------

AUXILIARY EQUIPMENT MAINTENANCE INSTRUCTIONS	PAGE 2-387
--	---------------

GENERAL SUPPORT MAINTENANCE INSTRUCTIONS	PAGE 3-1
--	-------------

LUBRICATION INSTRUCTIONS APPX E

DISTRIBUTION STATEMENT A. Approved for public release: distribution is unlimited.

HEADQUARTERS, DEPARTMENT OF THE ARMY
HEADQUARTERS, U.S. MARINE CORPS

MAY 1991

WARNING

RADIOACTIVE MATERIAL(S)



TRITIUM GAS (H₃)

This item contains radioactive material. Control of this radioactive material is mandated by Federal law. Immediately report any suspected lost or damaged items to your Radiation Safety Officer. If your Radiation Safety Officer cannot be reached, contact the TACOM-RI safety office during regular duty hours; or call the Rock Island Arsenal Police Dept. at DSN 793-6135 after duty hours.

All personnel who operate and/or maintain fire control equipment must be aware of the following special precautions:

Use adhesives, cleaning solvents, and cleaning compounds in well-ventilated area away from open flame. Adhesives, cleaning solvents, and sealing compounds are harmful to skin and clothing and may give off harmful vapor.

LOCAL RSO: _____ TELEPHONE: _____

A. RULES and REGULATIONS: Copies of the following rules and regulations are maintained at TACOM-RI, Rock Island, IL 61299-7630. Copies may be requested or information obtained by contacting the TACOM-RI Radiation Safety Officer (RSO), DSN 793-2962/2965, Commercial (309) 782-2962/2965.

- (1) 10CFR Part 19–Notices, Instructions and Reports to Workers; Inspections.
- (2) 10CFR Part 20–Standards for Protection Against Radiation.
- (3) 10CFR Part 21–Reporting of Defects and Noncompliance.
- (4) NRC license, license conditions, and license application.

B. SAFETY PRECAUTIONS: The radioactive material used in this instrument is tritium gas (H₃) sealed or in glass tubes. These sources illuminate the instrumentation for night operations. Tampering with or removal of the sources in the field is prohibited by Federal law. In the event there is no illumination, notify the local RSO or TACOM-RI RSO. If skin contact is made with any area contaminated with tritium, wash immediately with soap and water.

The beta radiation emitted by tritium is a hazard only if the vial or source is broken. Tritium can be taken into the body by inhalation, ingestion, or skin absorption/injection. If the vial is broken, the tritium gas will dissipate into the surrounding air. If released in a confined space such as a storage locker, container, unventilated room, or military vehicle, tritium is absorbed by lungs from air or by skin contact with contaminated surfaces. However, the body naturally eliminates absorbed tritium.

C. IDENTIFICATION: Instruments containing radioactive self-luminous vials are identified by means of radioactive warning labels (see above). These labels should not be defaced or removed and should be replaced immediately when necessary. Refer to the local RSO or the TACOM-RI RSO for instructions on handling, storage, or disposal.

WARNING (Cont)

RADIOACTIVE MATERIAL(S) (Cont)



TRITIUM GAS (H₃)

D. STORAGE: Spare equipment must be stored in the shipping container, as received, until installed on the weapon. Storage of these items is recommended to be in an outdoor shed-type storage or unoccupied building.

E. SHIPPING: All radioactively illuminated instruments will be evacuated to the appropriate echelon for inspection and repair. Non-illuminated instruments will be disposed of as radioactive waste. Contact installation Radiation Safety Officer.

F. EMERGENCY PROCEDURES: If a source breaks or is not illuminated, follow "SWIMN":

Stop - and think.

Warn - nearby personnel of situation to avoid additional exposure. Immediately open doors/hatches if exiting room/vehicle/area is not possible. If exiting, move upwind for 15 minutes.

Isolate - Do not handle broken tritium devices with bare hands. Use gloves (if available) or a bag. Quickly place item in plastic bag (item 4.1, appx B) (or, if bag not immediately available, wrap in plastic) and, if possible, move to a non-contaminated area. Wait for release by RSO to reduce spread of contamination.

Minimize - wash hands.

Notify - call the Radiation Safety Officer (RSO).

BATTERY WARNINGS



WARNING



Lithium – Thionyl Chloride (Li-SOCl₂) non-rechargeable batteries present a fire, explosion, and vapor hazard. Do not recharge, disassemble, heat above 212 °F (100 °C), incinerate, puncture, crush, short circuit the terminals, or expose contents to water. If they are abused, the high energy level can result in extreme heat or fire.

If battery enclosure shows signs of overheating or becomes hot to the touch, immediately turn off equipment (use on/off switch if supplied, or turn off by unscrewing/removing the battery caps).

Li-SOCl₂ batteries contain liquid SOCl₂, which fumes on contact with air. The fumes or vapors are highly toxic and the liquid is highly corrosive. Therefore, if you smell a sharp suffocating odor or hear a hissing sound, immediately turn off the equipment (use on/off switch if supplied, or turn off by unscrewing/removing the battery caps) and leave the area until odor dissipates. NOTE: Personnel can detect the smell at 1 ppm while concentrations of 10 ppm are dangerous. Once the odor has dissipated, always handle leaking batteries with personal protective equipment meeting ANSI or NIOSH/MSHA requirements.

Use only appropriate batteries for each particular item. Consult the technical manual for the correct battery. Never mix rechargeable batteries with non-rechargeable batteries to prevent damage and potential injury. Never short-circuit the terminals. Pay careful attention to the polarity diagram on battery enclosure. Do not install batteries backwards or severe equipment damage may result.

Use only class "D" fire extinguisher to extinguish batteries.

WARNING (Cont)

BATTERY WARNINGS (Cont)

Storage and Shipping

Store batteries in original packaging until ready for use. Examine packages/batteries for bulging, cracking, or signs of leakage before putting the batteries into equipment. Remove any damaged batteries from service and dispose of in accordance with local regulations. NOTE: When handling batteries that show signs of leaking, bulging, swelling, or deformity, personal protective equipment meeting ANSI or NIOSH/MSHA requirements must be used.

Store in cool, dry, well-ventilated areas separated from other combustible and hazardous materials. Storage of batteries over 100 °F (38 °C) will cause rapid loss of power.

Do not accumulate or store waste batteries for disposal for more than 90 days.

Do not mix hazardous and non-hazardous waste in the same package.

Do not package any battery if it is hot/warm. Package batteries only when they are cool to the touch.

Batteries designated for disposal shall be collected, transported, and disposed of in a manner that will prevent short-circuit (isolate by taping metal poles/terminals). Destroy physical integrity of battery by compaction or mutilation.

Non-usable batteries shall be disposed of in accordance with local regulations. Contact your local environmental office for instructions. Li-SOCl₂ batteries are classified as hazardous waste.

GENERAL WARNINGS

Do not drop tank of compressed nitrogen gas. When using in confined areas, use extreme care; gas could cause asphyxiation.

Do not purge or charge a collimator that has a damaged or broken radioactive light source.

Do not disassemble the radioactive reticle assembly.

First Aid

For further information on first aid, see FM 21-11.

HOWITZER

In raising nitrogen pressure in the recoil mechanism, failure to open or close valves when indicated could result in injury.

In charging the recoil mechanism with nitrogen when air cylinder assembly, recuperator cylinder assembly, or replenisher cylinder assembly are replaced, failure to open or close valves when indicated could result in injury.

In draining oil reserves with the cannon installed, cannon tube must be at zero elevation to prevent recoil mechanism and cannon from sliding out of battery in the event all the reserves are drained out of the system.

Safety strut assemblies must be installed when indicated to prevent accidental elevation of cannon which could result in injury.

Failure to bleed off all pressure in the recuperator cylinder assembly/equilibrators assembly when indicated could lead to severe injury.

WARNING (Cont)

GENERAL WARNINGS (Cont)

Use care when removing heavy components or parts. Use sling and hoist where indicated and have correct amount of personnel available where needed.

Do not remove both trails at the same time unless cannon and recoil mechanism have been removed. Ensure weapon is properly supported and is safe from tipping.

When removing and installing heavy items, make sure to have sufficient personnel and adequate lifting equipment. Equipment can cause serious injury if dropped.

Avoid prolonged contact with cleaning solvents and adhesives. To prevent damage to eyes, skin, and lungs: Always use cleaning solvents and adhesives in a well ventilated area. Do not permit smoking. Do not use near open flames. Wear gloves and eye protection.

For safety precautions, prior to beginning any painting operations, refer to TM 43-0139. Improper application or removal of CARC paint can be extremely hazardous to your health.

All lifting devices must be checked in accordance with local Standing Operating Procedure (SOP) to make sure they are in good working condition before starting lifting operation.

Cleaning Solvent is toxic and flammable. Use in well-ventilated area. Avoid breathing the vapors and keep away from ignition sources.

Local safety welding procedures must be followed when performing welding operation.

Safety glasses must be worn when performing drilling operations.

RECOIL EXERCISER

The components of the M45 Recoil Mechanism recoil exerciser are heavy; caution should be taken when handling them.

To avoid injury and/or death, be sure to clear the howitzer before starting exercise of M45 Recoil Mechanism.

Do not operate the recoil exerciser with the cannon tube locked in the tube stow/travel lock position. Howitzer damage and/or personnel injury may occur.

Stand clear of the howitzer while operating the recoil exerciser. Ensure other personnel are also at a safe distance to avoid injury.

M45 Recoil Mechanism will move out of battery once airline is opened. To avoid injury or damage, ensure all personnel and lines are clear.

To prevent injury to personnel, ensure that power switch of pump is either in the OFF position or the REMOTE ON position and that flow lever is in the OFF position before connection of electrical power.

To prevent injury to personnel, relieve oil pressure at fill port of pump.

Ensure all hydraulic pressure has been released before disconnecting hose assembly. To avoid injury to personnel, do not remove hydraulic hose when hydraulic cylinder is extended.

LIST OF EFFECTIVE PAGES

Dates of issue for original and changed pages are:

Original..... 0..... 23 May 1991
 Change..... 1..... 18 August 1997
 Change..... 2..... 28 February 1999
 Change..... 3..... 15 March 2002
 Change..... 4..... 30 September 2003

TOTAL NUMBER OF PAGES IN THIS PUBLICATION IS 584, CONSISTING OF THE FOLLOWING:

Page No.	*Change No.	Page No.	*Change No.	Page No.	*Change No.
Front Cover	4	2-50 - 2-57	0	2-156	1
A - B	4	2-58 - 2-59	3	2-157	2
Change instruction sheets for Change 4	4	2-60	0	2-158 - 2-159	0
Change instruction sheets for Change 3	3	2-61	1	2-160 -2-162	1
Change instruction sheets for Change 2	2	2-62 Blank	1	2-163 Deleted	1
Change instruction sheets for Change 1	1	2-63 - 2-64 Deleted	1	2-164	1
i	4	2-65	1	2-165 - 2-167	0
ii	3	2-66 - 2-76	0	2-168	1
2-6	1	2-77	1	2-169	0
2-7	0	2-78 - 2-79	0	2-170	1
2-8 - 2-9	1	2-80	3	2-171	0
2-10 - 2-14	0	2-80.1 - 2-80.12 Added	3	2-172	1
2-15	1	2-81	0	2-173	0
2-16	0	2-82	3	2-174	1
2-16.1 - 2-16.4 Added	3	2-83 - 2-84	0	2-175 - 2-177	0
2-17	3	2-85	3	2-178	3
2-18	1	2-86	0	2-179	1
2-19	2	2-87	3	2-180	3
2-20	3	2-88	1	2-180.1 Added	3
2-20.1 - 2-20.6 Added	3	2-88.1 - 2-88.6 Added	1	2-180.2 blank Added	3
2-21	3	2-89 - 2-110	0	2-181	0
2-22	0	2-111	3	2-182	1
2-23 - 2-24	3	2-112 - 2-118	0	2-183 - 2-189	0
2-24.1 Added	1	2-118.1 - 2-118.2	3	2-190 - 2-191	1
2-24.2 blank Added	1	Added		2-192 - 2-194	0
2-25 - 2-26	3	2-119 blank	3	2-195	2
2-27 - 2-33	0	2-120 - 2-121	3	2-196 - 2-203	0
2-34	3	2-122 - 2-136	0	2-204	1
2-35 - 2-41	0	2-136.1 - 2-136.10	3	2-205 - 2-216	0
2-42 - 2-43	3	Added		2-217	1
2-44 - 2-46	0	2-137	3	2-218	0
2-47	3	2-138	2	2-219	1
		2-139 - 2-141	1	2-220 - 2-228	0
		2-142 - 2-150	0	2-229	1
		2-151	3	2-230 - 2-231	0
		2-152 - 2-155 Deleted	1		

Page No.	*Change No.	Page No.	*Change No.	Page No.	*Change No.
2-232 - 2-233	1	2-315 blank	1	2-397 - 2-399	0
2-234 - 2-237	0	2-316	1	2-400	1
2-238 - 2-241	1	2-318	1	2-401	0
2-242 - 2-243	3	2-319 blank	1	2-402	1
2-244	1	2-320	1	2-402.1 Added	1
2-244.1	3	2-321	0	2-402.2 blank Added	1
2-244.2 blank Added	1	2-322	1	2-403 - 2-404	0
2-245	0	2-323	0	2-405	1
2-246 - 2-252	1	2-324	2	2-406	0
2-252.1 - 2-252.5 Added	1	2-325 - 2-326	0	3-1 - 3-4	0
2-252.6 blank Added	1	2-327	1	3-5 - 3-10	1
2-253 - 2-254	1	2-328	0	3-10.1 - 3.10.2 Added	1
2-255 - 2-256	3	2-329 blank	1	3-11	1
2-257	1	2-330 - 2-333	1	3-12 blank	0
2-258 - 2-264	0	2-334 blank	1	A-1	1
2-264.1 Added	2	2-335 - 2-340	0	A-2	3
2-264.2 - 2-264.10	3	2-341	1	B-1 - B-5	3
2-164.11 - 2-264.12 Added	3	2-342 - 2-346	0	B-6 blank Added	1
2-265 blank	2	2-346.1 Added	1	C-1	0
2-266	2	2-346.2 blank Added	1	C-2 - C-6	1
2-267 blank	1	2-347 - 2-352 Deleted	1	C-7	0
2-268 - 2-269	1	2-353 blank	1	C-8	1
2-270 blank	1	2-354	1	C-9 - C-12	0
2-271 - 2-272	1	2-355 - 2-356	0	C-13 - C-14	1
2-273 - 2-274 Deleted	1	2-356.1 Added	1	C-15	0
2-275	1	2-356.2 blank Added	1	C-16	2
2-276	0	2-357	1	C-17 - C-21 Added	3
2-277 - 2-279	1	2-358 - 2-361	0	C-22 blank Added	3
2-280 - 2-282	0	2-362 - 2-363	1	D-1 - D-3	0
2-283	1	2-364 - 2-369	0	D-4 blank	0
2-284 - 2-285 Deleted	1	2-370	1	E-1 - E-6	3
2-286	1	2-371 - 2-372	0	E-7 - E-10 Added	3
2-286.1 Added	2	2-373	3	Index-1	0
2-286.2 blank Added	2	2-374	0	Index-2 - Index-4	1
2-287 - 2-288 Deleted	1	2-375	2	Index-5 - Index-9	3
2-289	2	2-376	1	Index-10	0
2-290	1	2-377 - 2-378	0	Index-11	3
2-291 - 2-304	0	2-379	1	Index-12	0
2-305 - 2-306	1	2-380	2	Distribution Page	0
2-307	0	2-380.1 Added	2	Distribution Page Back	0
2-308	1	2-380.2 blank Added	2	blank	
2-309 blank	1	2-381 - 2-382	1	DA Form 2028 Sample	3
2-310	1	2-383 - 2-385	0	(front and back)	
2-311 blank	1	2-386	1	DA Form 2028 (front	3
2-312	1	2-387	3	and back)	
2-313 blank	1	2-388 - 2-395	0	Metric Chart	0
2-314	1	2-396	3	Back Cover	3
		2-396.1 - 2-396.2	3		
		2-396.3 - 2-396.10 Added	3		

*Zero in this column indicates an original page

B Change 4

CHANGE

NO. 4

HEADQUARTERS
DEPARTMENT OF THE ARMY
U.S. MARINE CORPS
WASHINGTON, D.C., 30 September 2003

TECHNICAL MANUAL
DIRECT SUPPORT AND GENERAL SUPPORT
MAINTENANCE MANUAL
FOR
HOWITZER, MEDIUM, TOWED
155MM: M198
(NSN 1025-01-026-6648) (EIC:3EL)

DISTRIBUTION STATEMENT A. Approved for public release: distribution is unlimited.

TM 9-1025-211-34, 23 May 1991, is changed as follows:

1. Remove old pages and insert new pages as indicated below.
2. New or changed material is indicated by a vertical bar in the margin of the page.
3. Added or revised illustrations are indicated by a vertical bar adjacent to the illustration or miniature pointing hands in the affected areas.
4. The front cover has been changed to indicate an address change in the distribution statement.

Remove Pages

A and B
i and ii
Cover

Insert Pages

A and B
i and ii
Cover

File this sheet in the front of the manual for reference purposes.

By Order of the Secretary of the Army and Commandant of the Marine Corps:

PETER J. SCHOOMAKER
General, United States Army
Chief of Staff

R. P. SHOCKEY
Director, Program Support
Marine Corps Systems Command

Official:

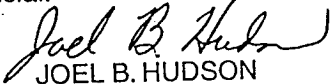
JOEL B. HUDSON
Administrative Assistant to the
Secretary of the Army

0306710

DISTRIBUTION: To be distributed in accordance with the Initial Distribution Number (IDN) 400549 requirements for TM 9-1025-211-34.

CHANGE
NO. 3

HEADQUARTERS
DEPARTMENT OF THE ARMY
U.S. MARINE CORPS
WASHINGTON, D.C., 15 March 2002

TECHNICAL MANUAL
DIRECT SUPPORT AND GENERAL SUPPORT
MAINTENANCE MANUAL
FOR
HOWITZER, MEDIUM, TOWED
155MM: M198
(NSN 1025-01-026-6648) (EIC:3EL)

DISTRIBUTION STATEMENT C. Distribution authorized to U.S. Government agencies and their contractors. This publication is required for administration and operational purposes, as determined 16 September 1994. Other requests for this document shall be referred to ATTN: AMSTA-LC-CIP-WT, TACOM-ROCK ISLAND, 1 Rock Island Arsenal, Rock Island, IL 61299-7630. Marine Corps: Request for this document must be referred to: Commandant of the Marine Corps (ARD), Washington, D.C. 20380-0001.

TM 9-1025-211-34, 23 May 1991, is changed as follows:

1. Remove old pages and insert new pages as indicated below.
2. New or changed material is indicated by a vertical bar in the margin of the page.
3. Added or revised illustrations are indicated by a vertical bar adjacent to the illustration or miniature pointing hands in the affected areas.
4. The front cover has been changed to indicate an address change in the distribution statement.

Remove Pages

a through c/(d blank)
None
i and ii
1-3 and 1-4
2-1 through 2-4
None
2-17 through 2-24
2-25 and 2-26
2-33 and 2-34
2-41 through 2-44
2-47 and 2-48
2-57 through 2-60
2-79 through 2-80
None

Insert Pages

a through d
A and B
i and ii
1-3 and 1-4
2-1 through 2-4
2-16.1 through 2-16.4
2-17 through 2-24
2-25 and 2-26
2-33 and 2-34
2-41 through 2-44
2-47 and 2-48
2-57 through 2-60
2-79 and 2-80
2-80.1 through 2-80.12

Remove Pages

2-81 and 2-82
2-85 through 2-88
2-111 and 2-112
None
2-119 through 2-122
2-137 and 2-138
2-151 and 2-156
2-177 through 2-180
2-241 through 2-244.1/(2-244.2 blank)
2-255 and 2-256
2-264.1 through 2-264.10
2-373 and 2-374
2-387 and 2-388
2-395 through 2-396.1/(2-396.2 blank)
A-1 and A-2
B-1 through B-5/(B-6 blank)
None
E-1 through E-6
Index-5 through Index-12
DA Form 2028-2 Sample
DA Form 2028-2
Front Cover

Insert Pages

2-81 and 2-82
2-85 through 2-88
2-111 and 2-112
2-118.1 and 2-118.2
(2-119 blank)/2-120 through 2-122
2-136.1 through 2-138
2-151 and 2-156
2-177 through 2-180.1/(2-180.2 blank)
2-241 through 2-244.1/(2-244.2 blank)
2-255 and 2-256
2-264.1 through 2-264.12
2-373 and 2-374
2-387 and 2-388
2-395 through 2-396.10
A-1 and A-2
B-1 through B-5/(B-6 blank)
C-17 through C-21/(C-22 blank)
E-1 through E-10
Index-5 through Index-12
DA Form 2028 Sample
DA Form 2028
Front Cover

File this sheet in the front of the manual for reference purposes.

By Order of the Secretary of the Army and Commandant of the Marine Corps:

ERIC K. SHINSEKI
General, United States Army
Chief of Staff

R. P. SHOCKEY
Director, Program Support
Marine Corps Systems Command

Official:

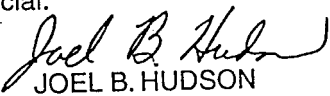
JOEL B. HUDSON
Administrative Assistant to the
Secretary of the Army

0200301

DISTRIBUTION: To be distributed in accordance with the Initial Distribution Number (IDN) 400549 requirements for TM 9-1025-211-34.

CHANGE

NO. 2

**TECHNICAL MANUAL
DIRECT SUPPORT AND GENERAL SUPPORT
MAINTENANCE MANUAL
FOR
HOWITZER, MEDIUM, TOWED
155MM: M198
(NSN 1025-01-026-6648) (EIC:3EL)**

DISTRIBUTION STATEMENT C. Distribution authorized to U.S. Government agencies and their contractors. This publication is required for administration and operational purposes, as determined 1 May 1988. Other requests for this document shall be referred to Director, Armament and Chemical Acquisition and Logistic Activity, ATTN: AMSTA-AC-NML, Rock Island, IL 61299-7630. Marine Corps: Request for this document must be referred to: Commandant of the Marine Corps (ARD), Washington, D.C. 20380-0001.

TM 9-1025-211-34, 23 May 1991, is changed as follows:

1. Whenever the use of SC 5180-95-CL-A43 is indicated, replace with SC 5180-95-A12 (Artillery and Mechanic's Ordnance Tool Kit).
2. Remove old pages and insert new pages as indicated below.
3. New or changed material is indicated by a vertical bar in the margin of the page.
4. Added or revised illustrations are indicated by a vertical bar adjacent to the illustration or miniature pointing hands in the affected areas.

Remove Pages

a and b
i and ii
1-3 through 1-9/(1-10 blank)
2-19 and 2-20
2-137 and 2-138
2-157 and 2-158
2-195 and 2-196
2-252.5/(2-252.6 blank)
2-265 and 2-266
None
None
2-289 and 2-290
2-323 and 2-324
2-375 and 2-376
2-379 and 2-380
None

Insert Pages

a and b
i and ii
1-3 through 1-9/(1-10 blank)
2-19 and 2-20
2-137 and 2-138
2-157 and 2-158
2-195 and 2-196
2-252.5/(2-252.6 blank)
2-264.1 through 2-264.10
(2-265 blank)/2-266
2-286.1/(2-286.2 blank)
2-289 and 2-290
2-323 and 2-324
2-375 and 2-376
2-379 and 2-380
2-380.1/(2-380.2 blank)

Remove Pages

B-1 through B-4
C-15/(C-16 blank)
Index-5 and Index-6
2028 (front and back)
Back Cover

Insert Pages

B-1 through B-4
C-15 and C-16
Index-5 and Index-6
2028 (front and back)
Back Cover

File this sheet in the front of the manual for reference purposes.

By Order of the Secretary of the Army and Commandant of the Marine Corps:

DENNIS J REIMER
General, United States Army
Chief of Staff

D.C. LEWIS
Colonel, USMC
Marine Corps Systems Command

Official:

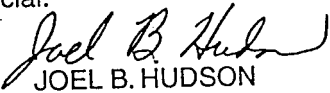
JOEL B. HUDSON
*Administrative Assistant to the
Secretary of the Army*

05519

DISTRIBUTION: To be distributed in accordance with the Initial Distribution Number (IDN) 400549 requirements for TM 9-1025-211-34.

CHANGE NO.

NO. 1

HEADQUARTERS
DEPARTMENT OF THE ARMY
U.S. MARINE CORPS
WASHINGTON, D.C. 18AUG1997

DIRECT SUPPORT AND GENERAL SUPPORT
MAINTENANCE MANUAL
FOR
HOWITZER, MEDIUM, TOWED: 155-MM, M198
(1025-01-026-6648) (EIC:3EL)

DISTRIBUTION STATEMENT C. Distribution authorized to U.S. Government agencies and their contractors. This publication is required for administration and operational purposes, as determined 1 May 1988. Other requests for this document shall be referred to Director, Armament and Chemical Acquisition and Logistics Activity, ATTN: AMSTA-AC-NML, Rock Island, IL 61299-7630. Marine Corps: Request for this document must be referred to: Commandant of the Marine Corps (ARE-B), Washington, D.C. 20380-0001.

TM 9-1025-211-34, 23 May 1991, is changed as follows to reflect configuration changes, approved suggestions from users, and changes in maintenance level of some procedures:

1. Remove old pages and insert new pages as indicated below.
2. New or changed material is indicated by a vertical bar in the margin of the page.
3. Added or revised illustrations are indicated by miniature pointing hands in the affected areas.

Remove pages

a and b
i and ii
1-3 through 1-6
2-5 through 2-10
2-15 through 2-20
2-23 and 2-24
None
2-33 and 2-34
2-41 through 2-44
2-47 through 2-50
2-57 through 2-62
2-63 and 2-64
2-65 and 2-66
2-77 and 2-78
2-87 and 2-88
None
2-111 and 2-112
2-139 through 2-142

Insert pages

a through c/(d blank)
i and ii
1-3 through 1-6
2-5 through 2-10
2-15 through 2-20
2-23 and 2-24
2-24.1/(2-24.2 blank)
2-33 and 2-34
2-41 through 2-44
2-47 through 2-50
2-57 through 2-61/(2-62 blank)
None
2-65 and 2-66
2-77 and 2-78
2-87 and 2-88
2-88.1 through 2-88.6
2-111 and 2-112
2-139 through 2-142

2-151 through 2-156	2-151 and 2-156
2-157 through 2-162	2-157 through 2-162
2-163 and 2-164	(2-163 blank)/2-164
2-167 through 2-174	2-167 through 2-174
2-177 through 2-182	2-177 through 2-182
2-189 through 2-192	2-189 through 2-192
2-203 and 2-204	2-203 and 2-204
2-217 through 2-220	2-217 through 2-220
2-229 through 2-234	2-229 through 2-234
2-237 through 2-244	2-237 through 2-244
None	2-244.1/(2-244.2 blank)
2-245 through 2-252	2-245 through 2-252
None	2-252.1 through 2-252.5/(2-252.6 blank)
2-253 through 2-258	2-253 through 2-258
2-265 and 2-266	2-265 and 2-266
2-267 and 2-268	(2-267 blank)/2-268
2-269 and 2-270	2-269/(2-270 blank)
2-271 through 2-274	2-271 and 2-272
2-275 through 2-280	2-275 through 2-280
2-283 through 2-288	2-283 and 2-286
2-289 and 2-290	2-289 and 2-290
2-305 through 2-308	2-305 through 2-308
2-3-309 and 2-310	(2-309 blank)/2-310
2-311 and 2-312	(2-311 blank)/2-312
2-313 and 2-314	(2-313 blank)/3-314
2-315 and 2-316	(2-315 blank)/2-316
2-317 and 2-318	2-317 and 2-318
2-319 and 2-320	(2-319 blank)/2-320
2-321 and 2-322	2-321 and 2-322
2-327 and 2-328	2-327 and 2-328
2-329 and 2-330	(2-229 blank)/2-330
2-331 through 2-334	2-331 through 2-333/(2-334 blank)
2-341 and 2-342	2-341 and 2-342
None	2-346.1/(2-346.2 blank)
2-347 through 2-354	(2-353 blank)/2-354
None	2-356.1/(2-356.2 blank)
2-357 and 2-358	2-357 and 2-358
2-361 through 2-364	2-361 through 2-364
2-369 and 2-370	2-369 and 2-370
2-375 and 2-376	2-375 and 2-376
2-379 through 2-382	2-379 through 2-382
2-385 and 2-386	2-385 and 2-386
2-395 and 2-396	2-395 and 2-396
None	2-396.1/(2-396.2 blank)
2-399 through 2-402	2-399 through 2-402
None	2-402.1/(2-402.2 blank)
2-405 and 2-406	2-405 and 2-406
3-5 through 3-10	3-5 through 3-10
None	3-10.1 and 3-10.2
3-11/(3-12 blank)	3-11/(3-12 blank)
A-1 and A-2	A-1 and A-2

B-3 through B-5/(B-6 blank)
C-1 through C-8
C-13 through C-15/(C-16 blank)
None
Index-1 through Index-10
Cover

B-3 through B-5/(B-6 blank)
C-1 through C-8
C-13 through C-15/(C-16 blank)
E-1 through E-6
Index-1 through Index-10
Cover

4. File this change sheet in the front of the publication for reference purposes.

By Order of the Secretary of the Army and Commandant of the Marine Corps:

DENNIS J REIMER
General, United States Army
Chief of Staff

Official:

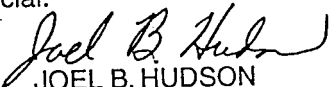
JOEL B. HUDSON
Administrative Assistant to the
Secretary of the Army

03786

DISTRIBUTION: To be distributed in accordance with the Initial Distribution Number (IDN) 400549 requirements for TM 9-1025-211-34.

DIRECT SUPPORT AND GENERAL SUPPORT MAINTENANCE MANUAL

**FOR
 HOWITZER, MEDIUM, TOWED: 155-MM, M198
 (1025-01-026-6648)**

REPORTING ERRORS AND RECOMMENDING IMPROVEMENTS

You can help improve this publication. If you find any mistakes or if you know of a way to improve the procedures, please let us know. Submit your DA Form 2028 (Recommended Changes to Publications and Blank Forms), through the Internet, on the Army Electronic Product Support (AEPS) website. The Internet address is <http://aeeps.ria.army.mil>. If you need a password, scroll down and click on "ACCESS REQUEST FORM". The DA Form 2028 is located in the ONLINE FORMS PROCESSING section of the AEPS. Fill out the form and click on SUBMIT. Using this form on the AEPS will enable us to respond quicker to your comments and better manage the DA Form 2028 program. You may also mail, fax, or email your letter, or DA Form 2028 direct to: AMSTA-LC-CI / TECH PUBS, TACOM-RI, 1 Rock Island Arsenal, Rock Island, IL 61299-7630. The email address is TACOM-TECH-PUBS@ria.army.mil. The fax number is DSN 793-0726 or Commercial (309) 782-0726. Marine Corps users submit NAVMC 10772 to: Commander, Marine Corps Logistics Bases (Code 850), 814 Radford Blvd., Albany, GA 31704-1128.

DISTRIBUTION STATEMENT A. Approved for public release: distribution is unlimited.

TABLE OF CONTENTS

	Page
HOW TO USE THIS MANUAL	iii
CHAPTER 1	
INTRODUCTION	1-1
Section I General Information	1-1
Section II Equipment Description and Data.....	1-4
Section III Principles of Operation.....	1-9

*This manual supersedes TM 9-1025-211-34, dated 15 July 1980, including all changes in their entirety.

ARMY TM 9-1025-211-34
MARINE CORPS TM 08198A-34/3

CHAPTER	2	DIRECT SUPPORT MAINTENANCE INSTRUCTIONS	2-1
Section	I	Repair Parts, Special Tools, TMDE, and Support Equipment	2-1
	II	Troubleshooting.....	2-1
	III	M199 Cannon — Maintenance Instructions	2-23
	IV	M45 Recoil Mechanism — Maintenance Instructions	2-58
	V	M39 Carriage — Maintenance Instructions.....	2-138
	VI	Auxiliary Equipment — Maintenance Instructions	2-387
	VII	M198 Howitzer — Maintenance Instructions	2-396.10
	VIII	Preparation for Storage of Shipment	2-406
	IX	Pre-embarkation Inspection of Materiel in Units Alerted for Overseas Movement	2-406
CHAPTER	3	GENERAL SUPPORT MAINTENANCE INSTRUCTIONS	3-1
Section	I	Troubleshooting.....	3-1
	II	General Support Maintenance Procedures	3-3
APPENDIX	A	REFERENCES	A-1
APPENDIX	B	EXPENDABLE/DURABLE SUPPLIES AND MATERIALS LIST.....	B-1
APPENDIX	C	ILLUSTRATED LIST OF MANUFACTURED ITEMS.....	C-1
APPENDIX	D	TORQUE LIMITS.....	D-1
APPENDIX	E	LUBRICATION INSTRUCTIONS	E-1
ALPHABETICAL INDEX			Index-1

HOW TO USE THIS MANUAL

GENERAL

- a. Whenever the masculine gender (i.e., crewman, repairman) is used in the manual, it includes both masculine and feminine genders.
- b. References in this manual are to pages or to other publications.
- c. Throughout this manual, the text is keyed to the illustrations by numbered callouts. When an item is called out in a procedure, a number in parentheses in the text corresponds with a circled number on the illustration.
- d. In most illustrations for the maintenance procedures, the howitzer is shown with the ballistic shields removed (for clarity).
- e. Procedures for unmodified howitzers, where applicable, are provided before procedures for modified howitzers.

INDEXES

- a. **Front Cover Index.** A page reference index of often used portions of the manual.
- b. **Table of Contents.** Lists all chapters and their sections, the appendixes, and an alphabetical index and gives page references to where they begin.
- c. **Official Names, Nomenclature, and Designations.** Throughout this manual, most items are referred to by their official nomenclatures. On page 1-3, the items referred to by their common names are listed alphabetically, followed by their official nomenclature.
- d. **Chapter Indexes.** Lists each section contained in the chapter and a page reference to the first page of the section.
- e. **Section Indexes.** Lists each paragraph contained in the section and a page reference to the first page of the paragraph.
- f. **Symptom Index.** This quick guide to troubleshooting lists common malfunctions in alphabetical order with a page reference to test or inspection and corrective action.
- g. **Alphabetical Index.** This index at the back of the book tells you where in the manual to find a particular subject.

MAINTENANCE PROCEDURES

There are two maintenance chapters. Chapter 2 contains direct support maintenance instructions and is divided into four individual maintenance sections covering the cannon, recoil mechanism, carriage, and auxiliary equipment. Chapter 3 covers instructions for general support maintenance. Each maintenance section contains detailed procedures for the maintenance tasks.

- a. **Initial Setup.** Is a list of everything needed in order to do the maintenance task:

- (1) **Special tools** — Lists tools that are contained in TM 9-1025-211-34P.

HOW TO USE THIS MANUAL (cont)

MAINTENANCE PROCEDURES (cont)

(2) **Materials/parts** — Lists 100 percent replaceable parts and expendable/durable items.

(3) **Personnel required** — Lists the number of personnel needed if more than one.

(4) **References** — Lists other publications containing necessary information.

(5) **Equipment conditions** — Lists conditions to be met before starting the procedures. The reference on the left of the condition is a page reference to instructions for setting up the condition.

b. Step-By-Step Procedures. Are illustrated procedures for maintenance authorized in the MAC (TM 9-1025-211-20&P). To replace parts, see TM 9-1025-211-34P.

CHAPTER 1 INTRODUCTION

Chapter Index

Section		Page
I.	General Information.....	1-1
II.	Equipment Description and Data.....	1-4
III.	Principles of Operation	1-9

Section I. GENERAL INFORMATION

Section Index

Paragraph		Page
1-1.	Scope.....	1-3
1-2.	Maintenance forms, records, and reports.....	1-3
1-3.	Destruction of Army materiel to prevent enemy use.....	1-3
1-4.	Preparation for storage or shipment.....	1-3
1-5.	Official nomenclature, names, and designations.....	1-3
1-6.	Reporting equipment improvement recommendations (EIR)	1-3
1-7.	Corrosion prevention and control (CPC)	1-4

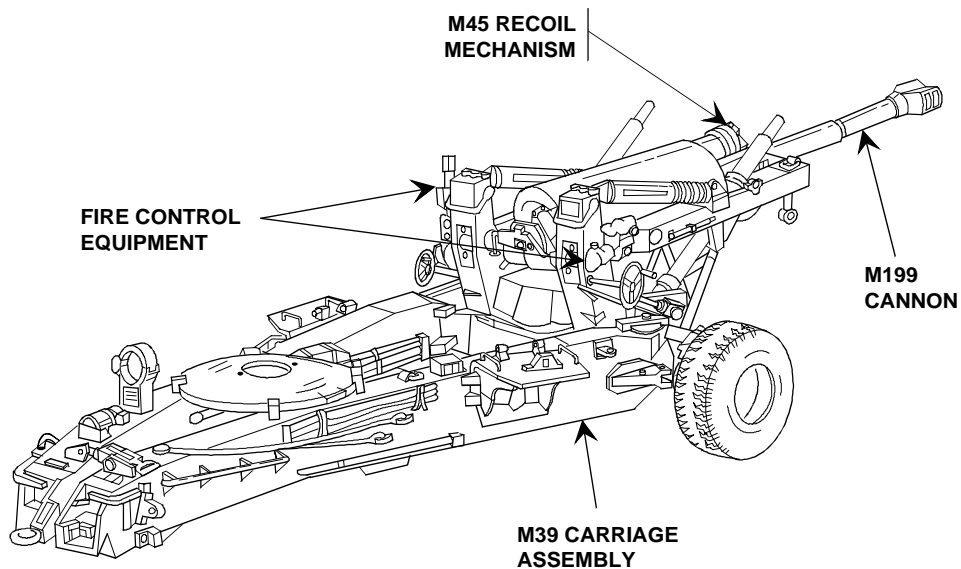

FULL EXTERNAL VIEW OF M198 155-MM MEDIUM TOWED HOWITZER

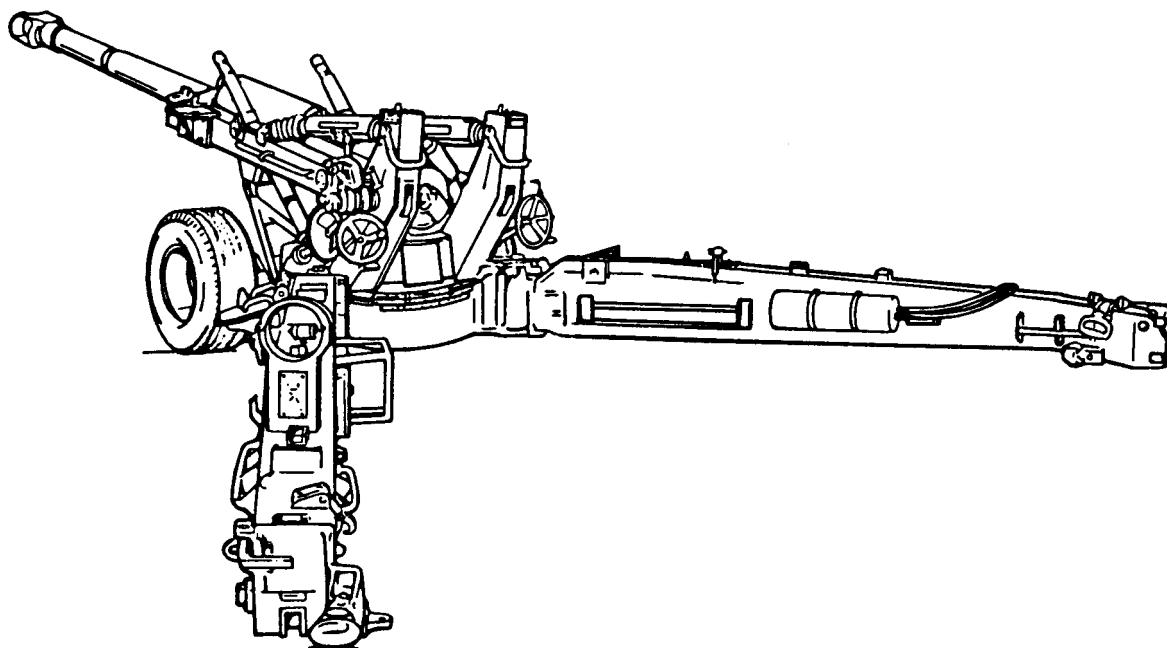

LEFT REAR VIEW

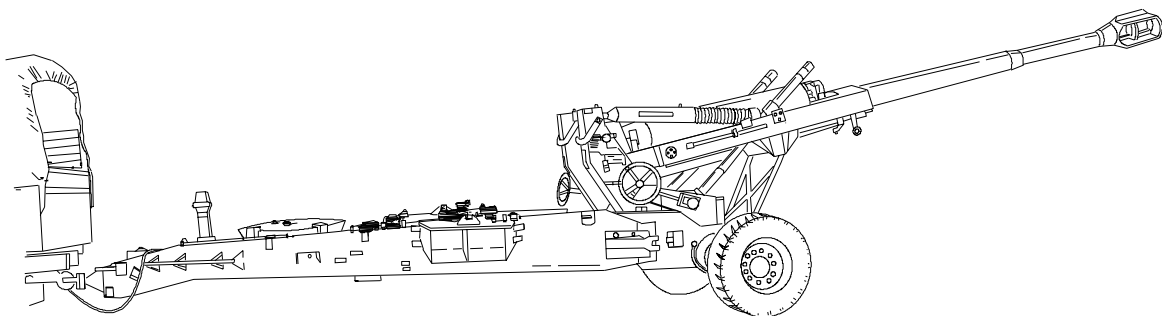

TOWED POSITION

1-1. SCOPE

- a. **Type of Manual.** Direct support and general support maintenance manual.
- b. **Model Number and Equipment Name.** Howitzer, Medium, Towed: 155-mm, M198.
- c. **Purpose of Equipment.** To provide artillery fire in support of ground-gaining troops.

1-2. MAINTENANCE FORMS, RECORDS, AND REPORTS

Department of the Army forms and procedures used for equipment maintenance will be those prescribed by DA PAM 738-750, The Army Maintenance Management System. Marine Corps personnel will use TM 4700-15/1, Equipment Record Procedures.

1-3. DESTRUCTION OF ARMY MATERIEL TO PREVENT ENEMY USE

Refer to TM 9-1025-211-20&P.

1-4. PREPARATION FOR STORAGE OR SHIPMENT

Refer to TM 9-1025-211-20&P.

1-5. OFFICIAL NOMENCLATURE, NAMES, AND DESIGNATIONS

This listing includes nomenclature cross-references used in this manual.

Common Name	Official Nomenclature
Bearing seat.....	Ball socket seat
Bleed valve assembly.....	Angle safety-relief-assembly valve
Bushing	Self-aligning bearing
Bushing clamp.....	Flange
Clevis assembly	Shackle
Capscrew	Internal wrench bolt
Dipstick.....	Liquid gage rod cap
Emergency relay valve	Automatic-bleed-down direct emergency linear valve
Flat washer.....	Non-metallic grommet
Linear baseplate.....	Speed shift base assembly
Oil reserve indicator	Pressure indicator
Paint	Polyurethane coating
Rest.....	Hand screw jack cap
Sensing bulb.....	Thermal sensing element

1-6. REPORTING EQUIPMENT IMPROVEMENT RECOMMENDATIONS (EIR)

If your M198 howitzer needs improvement, let us know. Send us an EIR. You, the user, are the only one who can tell us what you don't like about your equipment. Let us know why you don't like the design. Put it on an SF 368, Product Quality Deficiency Report. Mail it to us at ATTN: AMSTA-AR-QAW-C, TACOM-ARDEC, 1 Rock Island Arsenal, Rock Island, IL 61299-7300. FAX: Commercial (309) 782-6653, DSN 793-6653. E-mail: qawqdrs@ria.army.mil. Marine Corps personnel are encouraged to submit SF 368 in accordance with MCO 4855.10, Quality Deficiency report. We'll send you a reply.

1-7. CORROSION PREVENTION AND CONTROL (CPC)

a. Corrosion prevention and control (CPC) of Army materiel is a continuing concern. It is important that any corrosion problems with this item be reported so that the problem can be corrected and improvements can be made to prevent the problem in future items.

b. While corrosion is typically associated with rusting of metals, it can also include deterioration of other materials such as rubber and plastic. Unusual cracking, softening, swelling, or breaking of these materials may be a corrosion problem. If a corrosion problem is identified, it can be reported using SF 368, Product Quality Deficiency Report. Use of key words such as "corrosion", "rust", "deterioration", or "cracking" will ensure that the information is identified as a CPC problem. Submit the form to: ATTN: AMSTA-AR-QAW-C, TACOM-ARDEC, 1 Rock Island Arsenal, Rock Island, IL 61299-7300. FAX: Commercial (309) 782-6653, DSN 793-6653. E-Mail: qawqdrs@ria.army.mil. Marine Corps users submit Product Quality Deficiency Report to: Commander, ATTN: (Code 822-2), Marine Corps Logistics Bases, 814 Radford Blvd., Albany, GA 31704-1128.

Section II. EQUIPMENT DESCRIPTION AND DATA

Section Index

Paragraph	Page
1-8. Equipment characteristics, capabilities, and features	1-4
1-9. Location and description of major components	1-4
1-10. Modification and system improvement package	1-5
1-11. Equipment data	1-6

1-8. EQUIPMENT CHARACTERISTICS, CAPABILITIES, AND FEATURES

a. The purpose of the M198 howitzer is to provide general support field artillery firing for the light division by providing both nuclear and non-nuclear firing.

b. The M198 howitzer is a medium weight, low profile, split trail, extended range weapon. It may be displaced rapidly and has a 6400-mil speed shift. The howitzer may be towed by a vehicle or airlifted by a CH47D helicopter. The carriage has retractable wheels. The top carriage assembly can be rotated 180 degrees to decrease the overall length for shipment or storage.

c. The fire control equipment is operated by a gunner on the left side controlling direction (deflection) adjustments and an assistant gunner on the right side controlling elevation settings. It can also be operated by a gunner on the left side controlling both elevation and direction (deflection) settings. All light vials, reticles, and counters on the fire control and accessory equipment are radioactively illuminated.

1-9. LOCATION AND DESCRIPTION OF MAJOR COMPONENTS

Refer to TM 9-1025-211-20&P.

1-10. MODIFICATION AND SYSTEM IMPROVEMENT PACKAGE

NOTE

This manual covers both modified and unmodified M198 howitzers. Illustrations and procedures are for the modified howitzer, unless procedures for both modified and unmodified components or assemblies are required for clarity. Procedures that are for the modified howitzer and do not pertain to the unmodified howitzer can be ignored.

All US Army and US Marine Corps M198 howitzers are scheduled to be equipped with a system improvement package (MWO 9-1025-211-50-3). This MWO will affect the M39 carriage assembly only. The following is a brief description of the MWO and areas affected.

a. Top Carriage Assembly.

- (1) **Equilibrators:** Warnings on ballistic shields telling repairmen that nitrogen pressure must be bled to zero PSI before performing maintenance.
- (2) **Equilibrator adjustment screw:** Improved adjustment screw components which make adjustment of equilibrators easier, and covers to keep debris from the screw and slide area.
- (3) **Adjustment scales and pointers:** Moved to inside of top carriage uprights to eliminate entanglement of camouflage nets.
- (4) **Top carriage:** Self-contained automatic traverse lock which is easier to engage and eliminates damage to hydraulic brake line.
- (5) **Traverse mechanism shim:** Eliminates interference between traversing angle drive unit and actuator arm.
- (6) **Universal joint bellows:** Help contain lubricants where they belong.
- (7) **Cradle assembly:** Gussets welded to travel lock area to strengthen the travel lock struts.

b. Bottom Carriage Assembly.

- (1) **Suspension:** New axle bushings help eliminate excessive friction when raising the howitzer to the towed position.
- (2) **Firing baseplate:** New lock mechanism makes it easier to lock base plate in position.
- (3) **Hydraulic brake system:** The brake precheck system is a more efficient way to check brake condition prior to towing howitzer.
- (4) **Snorkel breather system:** Connects power booster to trail to eliminate water intake into the power booster during fording operations.
- (5) **Drain cock:** Provides crew easier access to bleed pressure in the emergency air tank.
- (6) **Covers and standoffs for brake lines, and brake hose assembly hookup diagram:** Help keep howitzer brake system operable.
- (7) **Lifting handle assemblies:** Located on either trail to provide extended lifting capacity to the howitzer.
- (8) **Retention assemblies:** Positive hold-downs for spade keys and airlift clevis assemblies, and receptacles for spade key and trail lock pins.

1-10. MODIFICATION AND SYSTEM IMPROVEMENT PACKAGE (cont)

(9) **Cam lock assembly:** Provides a positive lock for the trail lock mechanism.

(10) **Spade bracket and airlift eye bolt weldments:** Provide protection to help eliminate damage to these areas.

NOTE

Other modifications improving the M198 Howitzer are outlined below. The HyPAK modification procedures will be provided for both modified and unmodified configurations.

c. Breech Mechanism Assembly: A change in the release lever of the breechblock assembly adds a "click" to the latch so the user can be sure that the breech is closed. This feature improves safety during nighttime operations. Machining the lower lug of the breech ring assembly allows high angle firing (over 1200 mils).

d. Equilibrator Support Cover Modification: This is to correct and prevent future cracking in/around the top carriage towers, especially in the welded area around the bosses and top plate.

e. HyPAK (Hydraulic Power Assist Kit): This will be installed on some howitzers and is an electrically powered hydraulic system designed to be the primary method of raising and lowering the M198 wheels during howitzer emplacement, displacement, and carriage speed shifting.

1-11. EQUIPMENT DATA

a. Howitzer Performance Data.

Brakes:

Parking Manually operated disk
 Service Air/oil power disk

Breech lifeOriginal and five tubes

Breech type Screw block, interrupted thread

Dimensions (travel conditions):

Ground clearance at ball of firing baseplate 13 in. (0.33 m)
 Height at muzzle brake (towed position) 9 ft 6 in. (2.89 m)

Length:

Firing position (without spades) 36 ft 2 in. (11.02 m)
 Stowed position 24 ft 5 in. (7.44 m)
 Towed position 40 ft 6 in. (12.34 m)
 Tread (center-to-center) 7 ft 9 in. (2.36 m)
 Width (towed position) 9 ft 2 in. (2.79 m)

EFC rating TM 9-1000-202-14

Zone	EFC
8-S	1.000
8	0.500
7 Red	0.500
7 White	0.150
3-6	0.075
Green	0.075

Handwheel load:

Elevating 180 in.-lb (20.37 N-m)
 Traversing 120 in.-lb (13.50 N-m)

HyPAK	77 lb (34.96 kg)
Slave cable	70 lb (31.75 kg)
WHEELS	
Raising	65 sec ± 10 sec
Lowering	30 sec ± 10 sec
SPEED SHIFT	
Lowering	14 sec ± 5 sec
Length of recoil (zone 8 (M203)):	
Min to 500 mils	65 in. ± 6 (165.10 cm ± 15.24)
501 to 800 mils	56 in. ± 7 (142.24 cm ± 17.78)
801 to max mils	50 in. ± 2 (127.0 cm ± 5.08)
Lunette load (30 in. (76.20 cm)):	
Stowed position	3500 lb (1587.60 kg)
Towed position	500 lb (226.80 kg)
Maximum ranges	30,000 m (32,808 yd) w/M203 propelling charge, charge 8 (w/RAP rd, M549A1) 5000 to 9900 m (5468.1 to 10826.8 yd) w/M3 propelling charge using charges 2 thru 5
Maximum terrain slope	10-degree cant
Maximum towing speed:	
Cross country	15 mph (8.04 km/hr)
Improved roads	45 mph (72.40 km/hr)
Secondary roads	30 mph (48.27 km/hr)
Mils of movement per turn of handwheel:	
Elevating	10 mils
Traversing	10 mils
Muzzle brake	Double baffle
On-carriage elevating range	-75 to +1275 mils
Prime mover	5-ton (4536-kg) truck
Rate of fire	4 rounds/minute—maximum, 2 rounds/minute—sustained or as determined by thermal warning device
Recoil mechanism	Hydropneumatic, variable, dependent
Speed shift range	6400 mils
Tires (radial)	
Pressure	110 psi (758 kPa)
Size	11.0 to 20.0, 16 ply
Load range	H
Traversing range	400 mils left and 400 mils right of center
Tube life	Based on wear factor (pullover gage reading) (Refer to TM 9-1000-202-14.)
Weight (including basic issue items) (without HyPAK)	16,000 lb (7264.0 kg)

1-11. EQUIPMENT DATA (cont)

b. Fire Control Equipment Performance Data.

M17 Fire Control Quadrant:

Correction ± 95 mils
Elevation -280 to +1433 mils
Least increment reading (counters) 1 mil
Radioactive material:
Max surface radiation 0 millirad per hour
Tritium H₃ 1.86 curies
Weight 7.50 lb (3.40 kg)

M18 Fire Control Quadrant:

Correction ±95 mils
Elevation -280 to +1433 mils
Least increment reading (counters) 1 mil
Radioactive material:
Max surface radiation 0 millirad per hour
Tritium H₃ 1.95 curies
Weight 7.50 lb (3.40 kg)

M171 Telescope and Quadrant Mount:

Cross level adjustment:
Left 178 mils
Right 178 mils
Elevation -270 to +1333 mils
Pitch level adjustment:
Aft 178 mils
Fore 178 mils
Radioactive material:
Max surface radiation 0 millirad per hour
Tritium H₃ 0.15 curies
Weight:
Adapter assembly 3.25 lb (1.47 kg)
Mount 75 lb (34.02 kg)
Optical instrument support 2 lb (0.91 kg)

M172 Telescope and Quadrant Mount:

Boresighting:
Azimuth ± 18 mils
Elevation ± 15 mils
Cross level adjustment ± 34 degrees
Weight:
Adapter assembly 4.75 lb (2.15 kg)
Mount 27.50 lb (12.47 kg)

M137 Panoramic Telescope:

Field of view 10 degrees
Movement:
Azimuth counter(increasing clockwise) 6400 mils
Azimuth (deflection) 6400 mils
Correction (AZ) ± 95 mils
Elevation ± 300 mils
Least increment reading (AZ) 0.25 mil
Power 4X
Radioactive material:
Max surface radiation 0 millirad per hour
Tritium H₃ 5.10 curies
Weight 19 lb (8.62 kg)

M138 Elbow Telescope:

Elevation 60 mils
Field of view 8 degrees
Power 8X
Radioactive material:
Max surface radiation 0 millirad per hour
Tritium H₃ 4.4 curies
Weight 8 lb (3.63 kg)

c. Auxiliary Equipment Performance Data.

M139 Alinement Device:

Radioactive material:
Max surface radiation 0 millirad per hour
Tritium H₃ 3 curies
Weight 1.60 lb (0.73 kg)

Section III. PRINCIPLES OF OPERATION

1-12. PRINCIPLES OF OPERATION

Refer to TM 9-1025-211-20&P.

CHAPTER 2 DIRECT SUPPORT MAINTENANCE INSTRUCTIONS

CHAPTER INDEX

Section		Page
I.	Repair Parts, Special Tools, TMDE, and Support Equipment	2-1
II.	Troubleshooting	2-1
III.	M199 Cannon—Maintenance Instructions	2-23
IV.	M45 Recoil Mechanism—Maintenance Instructions.....	2-58
V.	M39 Carriage—Maintenance Instructions	2-138
VI.	Auxiliary Equipment—Maintenance Instructions	2-387
VII.	M198 Howitzer—Maintenance Instructions	2-396
VIII.	Preparation for Storage or Shipment.....	2-406
IX.	Pre-Embarkation Inspection of Materiel in Units Alerted for Overseas Movement	2-406

Section I. REPAIR PARTS, SPECIAL TOOLS, TMDE, AND SUPPORT EQUIPMENT

Section Index

Paragraph		Page
2-1.	Common tools and equipment	2-1
2-2.	Special tools, TMDE, and support equipment	2-1
2-3.	Repair parts	2-1

2-1. COMMON TOOLS AND EQUIPMENT

For authorized common tools and equipment refer to the Modified Table of Organization and Equipment (MTOE) applicable to your unit.

2-2. SPECIAL TOOLS, TMDE, AND SUPPORT EQUIPMENT

Refer to TM 9-1025-211-20&P and TM 9-1025-211-34P.

2-3. REPAIR PARTS

Repair parts are listed and illustrated in the Repair Parts and Special Tools List (TM 9-1025-211-34P) for this equipment.

Section II. TROUBLESHOOTING

Section Index

Paragraph		Page
2-4.	Troubleshooting Information.....	2-2

2-4. TROUBLESHOOTING INFORMATION

- a. Use the information in this section with troubleshooting in TM 9-1025-211-20&P. It provides instructions where the unit maintenance manual refers to direct support maintenance for corrective action.
- b. Use the symptom index as a quick guide to troubleshooting. Common malfunctions are listed in alphabetical order under each major assembly with a page reference to the test or inspection and corrective action in the troubleshooting table.
- c. The table lists the common malfunctions which you may find during the operation or maintenance of the M198 howitzer or its components. Perform the tests/inspections and corrective actions in the order listed.
- d. This manual cannot list all malfunctions that may occur, nor all tests or inspections and corrective actions. If a malfunction is not listed or is not corrected by listed corrective actions, notify your supervisor.

SYMPTOM INDEX

	Troubleshooting Procedure (Page)
AIR CYLINDER ASSEMBLY	
Nitrogen pressure leaks	2-12
AIR PRESSURE GAGE ASSEMBLY	
Does not register reading when checking equilibrator cylinders	2-22
AMMUNITION LOADING TRAY	
Is defective	2-21
BOTTOM CARRIAGE ASSEMBLY	
Air brakes	
Are locked	2-19
Are weak	2-20
Handbrakes fail to hold in park position	2-19
Lights in vehicular taillight do not illuminate	2-20
Speed shift assembly cannot be extended or retracted	2-19
Wheels	
Will not move up or down	2-17
Wobble	2-18
BREECHBLOCK ASSEMBLY	
Does not close completely	2-6
Does not open	2-6

BREECH MECHANISM ASSEMBLY

Does not operate freely.....2-6

CANNON TUBE

Lands are flattened2-5

ELEVATING MECHANISM

Does not work2-13

Elevating handwheel difficult to turn.....2-14

FRONT YOKE

Oil leaks2-13

HyPAK SYSTEM

Wheels and/or speedshift fail to raise or lower2-16.1

NITROGEN CHARGING ASSEMBLY

Charging pressure cannot be obtained.....2-22

3000-lb gage does not function.....2-21

4000-lb gage does not function.....2-21

NITROGEN CHARGING KIT

Is incomplete.....2-21

NITROGEN HOSE ASSEMBLY

Will not hold nitrogen under pressure2-21

RECOIL CYLINDER ASSEMBLY

More than two reserves of oil leak from end per day2-11

RECOIL MECHANISM

Cannon

Does not return to battery.....2-8

Slams into battery.....2-8

Oil reserve indicator

Does not work2-7

Registers less than two reserves2-7

Registers more than 10 reserves2-7

Recoil

Cycle is irregular.....2-9

There is overrecoil.....2-10

There is underrecoil.....2-10

SYMPTOM INDEX (cont)

**Troubleshooting
 Procedure
 (Page)**

RECUPERATOR CYLINDER ASSEMBLY

Nitrogen pressure leaks2-12
 More than two reserves of oil leak per day2-12

REPLENISHER CYLINDER ASSEMBLY

Nitrogen pressure leaks2-11
 Oil leaks2-11

THERMAL WARNING DEVICE

Dial pointer will not return to ambient temperature2-5
 Has moisture inside of dial window2-5
 Housing assembly
 Is dislocated from annular groove on cannon tube or distance between rear
 edge of housing assembly and front edge of barrel clamp is more than
 6 in. ± 0.25 (15.24 cm ± 0.64)2-5
 Is loose on cannon tube2-4

TOP CARRIAGE ASSEMBLY

■ Difficult to traverse or has uneven operation2-16.1

TRAVERSING MECHANISM

Cannon overtravels when traversing handwheel is released2-16
 Traversing handwheel play exceeds 1/12 turn (3-1/8 in. (7.94 cm))2-16

Table 2-1. DIRECT SUPPORT TROUBLESHOOTING

MALFUNCTION	TEST OR INSPECTION	CORRECTIVE ACTION
--------------------	---------------------------	--------------------------

THERMAL WARNING DEVICE

1. THERMAL WARNING DEVICE HOUSING ASSEMBLY IS LOOSE ON CANNON TUBE.

Observe visually.

Tighten four hose clamps, and adjust (p 2-23).

Table 2-1. DIRECT SUPPORT TROUBLESHOOTING (cont)

MALFUNCTION

TEST OR INSPECTION

CORRECTIVE ACTION

2. THERMAL WARNING DEVICE HAS MOISTURE INSIDE OF DIAL WINDOW.

Observe visually.

- a. Purge, using fire control purging and charging equipment per TM 9-1025-211-20&P.
- b. Replace gasket (p 2-35).

3. THERMAL WARNING DEVICE DIAL POINTER WILL NOT RETURN TO AMBIENT TEMPERATURE.

Step 1. Check for damaged spring.

Replace spring (p 2-35).

Step 2. Check calibration.

Calibrate (p 2-35).

Step 3. Check for corroded internal parts.

Replace damaged parts, and calibrate (p 2-35).

4. HOUSING ASSEMBLY IS DISLOCATED FROM ANNULAR GROOVE ON CANNON TUBE OR DISTANCE BETWEEN REAR EDGE OF HOUSING ASSEMBLY AND FRONT EDGE OF BARREL CLAMP IS MORE THAN 6 IN. ± 0.25 (15.24 CM ± 0.64).

Check for improperly tightened hose clamps.

Realign housing, and tighten hose clamps to proper position (p 2-23).

CANNON TUBE

5. CANNON TUBE LANDS ARE FLATTENED.

Check for imperfect centering, severe ramming of projectile, or too great a projectile clearance starting balloting lands. Check for chipped, worn, and raised cannon tube lands.

Refer to TM 9-1000-202-14 and TM 9-4933-200-35.

2-4. TROUBLESHOOTING INFORMATION (cont)

Table 2-1. DIRECT SUPPORT TROUBLESHOOTING (cont)

MALFUNCTION	TEST OR INSPECTION	CORRECTIVE ACTION
BREECH MECHANISM ASSEMBLY		
6.	BREECH MECHANISM ASSEMBLY DOES NOT OPERATE FREELY.	
	Step 1.	Check for burrs on breechblock assembly threads or breech ring threads (p 2-49). Remove burrs.
	Step 2.	Check for insufficient lubrication. Lubricate in accordance with appendix E.
	Step 3.	Check for dirty, damaged, worn, or improperly assembled obturator spindle assembly (p 2-49). Disassemble, clean, and examine parts for damage. Reassemble correctly.
	Step 4.	Check for worn or broken parts in breech mechanism assembly. Replace damaged parts (p 2-49).
BREECHBLOCK ASSEMBLY		
7.	BREECHBLOCK ASSEMBLY DOES NOT OPEN.	
		Try to open breechblock assembly. Ram breechblock assembly at end from muzzle brake. Clean per appendix E or replace defective parts (p 2-49).
8.	BREECHBLOCK ASSEMBLY DOES NOT CLOSE COMPLETELY.	
	Step 1.	Check for burrs on breechblock assembly threads or breech ring threads (p 2-49). Remove burrs.
	Step 2.	Check for insufficient lubrication. Lubricate in accordance with TM 9-1025-211-10, appx F.

Table 2-1. DIRECT SUPPORT TROUBLESHOOTING (cont)

MALFUNCTION	TEST OR INSPECTION	CORRECTIVE ACTION
RECOIL MECHANISM		
9.	OIL RESERVE INDICATOR REGISTERS MORE THAN 10 RESERVES.	
	Step 1.	Check for overheated system. Drain to four reserves, and re-establish reserve after system cools (p 2-58).
	Step 2.	Check for air in oil in recuperator cylinder assembly. This may indicate nitrogen pressure leak past floating piston. a. Purge, and refill recoil mechanism (p 2-58). b. If leak persists, replace seals on recuperator cylinder or replenisher assembly (p 2-58).
10.	OIL RESERVE INDICATOR REGISTERS LESS THAN TWO RESERVES.	
	Step 1.	Check visually. Add oil per TM 9-1025-211-20&P until four reserves are shown.
	Step 2.	Check for leak in recoil mechanism. a. Tighten loose plugs and fittings on recuperator cylinder assembly, replenisher assembly, front yoke, middle yoke, and rear yoke. b. Replace defective parts (p 2-58).
11.	OIL RESERVE INDICATOR DOES NOT WORK.	
		Check for plugged restrictor check valve or oil line. a. Clean with cleaning compound (item 7, appx B), or replace restrictor check valve or oil line (p 2-111). b. If problem persists, replace damaged replenisher cylinder assembly (p 2-88).

2-4. TROUBLESHOOTING INFORMATION (cont)

Table 2-1. DIRECT SUPPORT TROUBLESHOOTING (cont)

MALFUNCTION	TEST OR INSPECTION	CORRECTIVE ACTION
-------------	--------------------	-------------------

RECOIL MECHANISM (cont)

12. CANNON DOES NOT RETURN TO BATTERY.

- Step 1.** Check for recuperator nitrogen pressure less than 1100 psi (7585 kPa) on gage on nitrogen checking device (p 2-58).
Charge recoil mechanism to 1100 psi (7585 kPa) at ambient temperature (p 2-58).
- Step 2.** Check for nitrogen or hydraulic leaks in the recoil mechanism.
Replace as necessary (p 2-58 or 2-88).
- Step 2.1** Check for nitrogen leaks on indicator rod.
Replace seals as necessary (p 2-88).
- Step 3.** Check restrictor check valve and oil line between replenisher cylinder assembly and recuperator cylinder assembly for blockage (p 2-111).
a. Clean with cleaning compound (item 7, appx B).
b. If problem is not solved, replace restrictor check valve or oil line (p 2-111).
- Step 4.** Check oil reserve indicator for less than two reserves.
Add oil (hydraulic fluid) (item 14, appx B) if required (p 2-58).
- Step 5.** Check for dirty or damaged bearing unit housing (p 2-172).
a. Lubricate (TM 9-1025-211-10, appx F).
b. If problem persists, remove wiper rings (p 2-172); clean with cleaning compound (item 7, appx B); and lubricate per TM 9-1025-211-10, appx F.
c. If problem is still not solved, replace sleeve bearing and wiper rings (p 2-172).

13. CANNON SLAMS INTO BATTERY.

- Step 1.** Check for nitrogen pressure more than 1100 psi (7585 kPa).
Lower pressure to 1100 psi (7585 kPa) at ambient temperature (p 2-58).

Table 2-1. DIRECT SUPPORT TROUBLESHOOTING (cont)

MALFUNCTION	TEST OR INSPECTION	CORRECTIVE ACTION
	Step 2.	Check for air in the oil, using liquid tool assembly and recoil hose assembly. Purge, and refill recoil mechanism (p 2-58).
	Step 3.	Check for defective recuperator cylinder assembly. Replace defective recuperator cylinder assembly (p 2-111).
	Step 4.	Check oil reserve indicator for more than 10 reserves. a. Drain oil to four reserves (p 2-58). b. Replace damaged replenisher cylinder assembly (p 2-88).
	Step 5.	Check for blocked restrictor check valve between recuperator cylinder assembly and replenisher cylinder assembly. Clean with cleaning compound (item 7, appx B) or replace damaged restrictor check valve (p 2-111).
14. RECOIL CYCLE IS IRREGULAR.		
	Step 1.	Check for damaged or improperly lubricated guide assemblies. a. Lubricate guide assemblies per TM 9-1025-211-10, appx F. █ b. Replace damaged guide assemblies (p 2-178).
	Step 2.	Check for proper adjustment of variable recoil parts and for broken and missing parts. a. Adjust variable recoil parts (p 2-141). b. Replace broken or missing parts (p 2-95 or 2-141).
	Step 3.	Check for dirty or damaged bearing unit housing. a. Lubricate in accordance with TM 9-1025-211-10, appx F. █ b. If problem persists, remove wiper rings (p 2-172); clean with cleaning compound (item 7, appx B); and lubricate per TM 9-1025-211-10, appx F. █ c. If problem is still not solved, replace sleeve bearing and wiper rings (p 2-172).

2-4. TROUBLESHOOTING INFORMATION (cont)

Table 2-1. DIRECT SUPPORT TROUBLESHOOTING (cont)

MALFUNCTION	TEST OR INSPECTION	CORRECTIVE ACTION
-------------	--------------------	-------------------

RECOIL MECHANISM (cont)

14. RECOIL CYCLE IS IRREGULAR. (cont)

Step 4. Check for more than 10 reserves on oil reserve indicator.
Drain oil to four reserves (p 2-58).

15. THERE IS OVERRECOIL.

Step 1. Check for broken or inoperative variable recoil parts.
Replace variable recoil parts as required (p 2-141).

Step 2. Check for nitrogen pressure less than 1100 psi (7585 kPa).
Increase pressure to 1100 psi (7585 kPa) at ambient temperature (p 2-58).

Step 3. Check for broken air line.
Replace as necessary (p 2-58).

Step 4. Check for broken oil line.
Replace as necessary (p 2-111).

16. THERE IS UNDERRECOIL.

Step 1. Check for nitrogen pressure more than 1100 psi (7585 kPa) on gage located on nitrogen checking device.
Lower pressure to 1100 psi (7585 kPa) at ambient temperature (p 2-58).

Step 2. Check for oil reserves over 10 reserves on oil reserve indicator.
Drain oil to four reserves.

Step 3. Check for broken or inoperative variable recoil parts.
Replace variable recoil parts as required (p 2-141).

Table 2-1. DIRECT SUPPORT TROUBLESHOOTING (cont)

MALFUNCTION	TEST OR INSPECTION	CORRECTIVE ACTION
REPLENISHER CYLINDER ASSEMBLY		
17. OIL LEAKS FROM REPLENISHER CYLINDER ASSEMBLY.		
Step 1.	Check for loose fitting.	<ul style="list-style-type: none">a. Tighten fitting.b. Replace fitting, if required (p 2-88).
Step 2.	Check for loose setscrew or defective gasket.	<ul style="list-style-type: none">a. Tighten setscrew.b. If leak persists, replace gasket (p 2-88).
Step 3.	Check for leaking plug.	Replace damaged replenisher cylinder assembly (p 2-88).
18. NITROGEN PRESSURE LEAKS FROM REPLENISHER CYLINDER ASSEMBLY.		
Step 1.	Check for nitrogen pressure leak between air cylinder assembly and replenisher cylinder assembly (p 2-58).	Replace preformed packing on replenisher cylinder assembly (p 2-88).
Step 2.	Check for leaking end assembly.	Replace damaged replenisher cylinder assembly (p 2-88).
RECOIL CYLINDER ASSEMBLY		
19. MORE THAN TWO RESERVES OF OIL LEAK FROM END OF RECOIL CYLINDER ASSEMBLY PER DAY.		
Step 1.	Check for damaged recoil preformed packings and ring spacers.	Replace damaged preformed packings and ring spacers (p 2-100).
Step 2.	Check recoil cylinder assembly for leakage.	Replace damaged recoil cylinder assembly (p 2-100).

2-4. TROUBLESHOOTING INFORMATION (cont)

Table 2-1. DIRECT SUPPORT TROUBLESHOOTING (cont)

MALFUNCTION	TEST OR INSPECTION	CORRECTIVE ACTION
RECUPERATOR CYLINDER ASSEMBLY		
20. MORE THAN TWO RESERVES OF OIL LEAK FROM RECUPERATOR CYLINDER ASSEMBLY PER DAY.		
	Step 1.	Check for loose fitting at elbow. Replace damaged parts as authorized (p 2-111).
	Step 2.	Check for loose seal retaining rings connected to front yoke. a. Tighten rings. b. If leak persists, replace preformed packing (p 2-111).
	Step 3.	Check for loose setscrew (oil purge hole). a. Tighten setscrew. b. If leak persists, replace gasket (p 2-111).
21. NITROGEN PRESSURE LEAKS FROM RECUPERATOR CYLINDER ASSEMBLY.		
	Step 1.	Check for loose crossover line fittings or leaking check valve. a. Tighten fittings and check valve. b. If leak persists, replace defective parts (p 2-111).
	Step 2.	Check for leaking head. Replace defective recuperator cylinder assembly (p 2-111).
	Step 3.	Check for leaking preformed packing on crossover line. Replace damaged preformed packing (p 2-111).
AIR CYLINDER ASSEMBLY		
22. NITROGEN PRESSURE LEAKS FROM AIR CYLINDER ASSEMBLY.		
	Step 1.	Check for loose crossover line fittings. a. Tighten fittings. b. If leak persists, replace defective parts (p 2-129).

Table 2-1. DIRECT SUPPORT TROUBLESHOOTING (cont)

MALFUNCTION	TEST OR INSPECTION	CORRECTIVE ACTION
	Step 2.	Check for leaking head. Replace defective air cylinder assembly (p 2-129).
	Step 3.	Check for leaks around preformed packing on crossover line. Replace damaged preformed packing (p 2-129).
FRONT YOKE		
23. OIL LEAKS FROM FRONT YOKE.		
	Step 1.	Check for loose oil valve assembly or damaged gasket on front yoke. a. Tighten oil valve assembly. b. Replace defective oil valve assembly and gasket (p 2-134).
	Step 2.	Check for loose plugs on front yoke. a. Tighten plugs. b. If problem persists, replace gaskets (p 2-136).
ELEVATING MECHANISM		
24. ELEVATING MECHANISM DOES NOT WORK.		
	Step 1.	Check friction clutch for proper operation. a. Perform service (p 2-204). b. Repair friction clutch (p 2-204).
	Step 2.	Remove access covers, and check for dirty or broken gears in elevating angle drive unit. Clean with cleaning compound (item 7, appx B), and replace worn or broken authorized parts (p 2-182).
	Step 3.	Check for inoperative elevating ball screw. Replace elevating screw assembly (p 2-191).
	Step 4.	Elevating screw assembly loose or out of adjustment. Time elevating mechanism (p 2-191).

2-4. TROUBLESHOOTING INFORMATION (cont)

Table 2-1. DIRECT SUPPORT TROUBLESHOOTING (cont)

MALFUNCTION	TEST OR INSPECTION	CORRECTIVE ACTION
-------------	--------------------	-------------------

ELEVATING MECHANISM (cont)

25. ELEVATING HANDWHEEL DIFFICULT TO TURN.

- Step 1.** Check for improperly adjusted equilibrator cylinder.
Adjust equilibrator adjusting screw per TM 9-1025-211-10.
- Step 2.** Check for jammed or broken gears.
Repair elevating angle drive unit (p 2-182).
- Step 3.** Check for difficulty during operation in elevation.
Adjust equilibrator adjusting screw to compensate for temperature change per TM 9-1025-211-10.
- Step 4.** Check for difficulty during operation in quadrant elevation with dial pointer at maximum (+) position.
Place howitzer in travel lock position and dial pointer at zero. Check nitrogen pressure in equilibrator cylinder and add nitrogen as necessary (p 2-151).
- Step 5.** Check nitrogen filler valve for leaks around the check valve stem and body with soapy solution (item 30, appx B).

CAUTION

Do not overtorque swivel nut.

- a. Tighten swivel nut to 120.00 to 130.00 in.-lb (13.56 to 14.69 N-m).
- b. If leaks continue, bleed nitrogen pressure from equilibrator cylinder (p 2-151). Replace faulty check valve (p 2-151).

NOTE

If less than 30 days has elapsed since step 5 was completed, with no extreme temperature changes and the howitzer is again difficult to elevate, perform steps 4 thru 6. Nitrogen loss of 30 psi (40.68 kPa) or less per month is acceptable.

Table 2-1. DIRECT SUPPORT TROUBLESHOOTING (cont)

MALFUNCTION	TEST OR INSPECTION	CORRECTIVE ACTION
-------------	--------------------	-------------------

CAUTION

When removing machine plug (1), oil may squirt out under pressure. Let pressure dissipate before completely removing machine plug. Loss of oil from the insert end whether under pressure or not does not cause the equilibrator assembly to be unserviceable. The oil should be replenished as required (TM 9-1025-211-20&P).

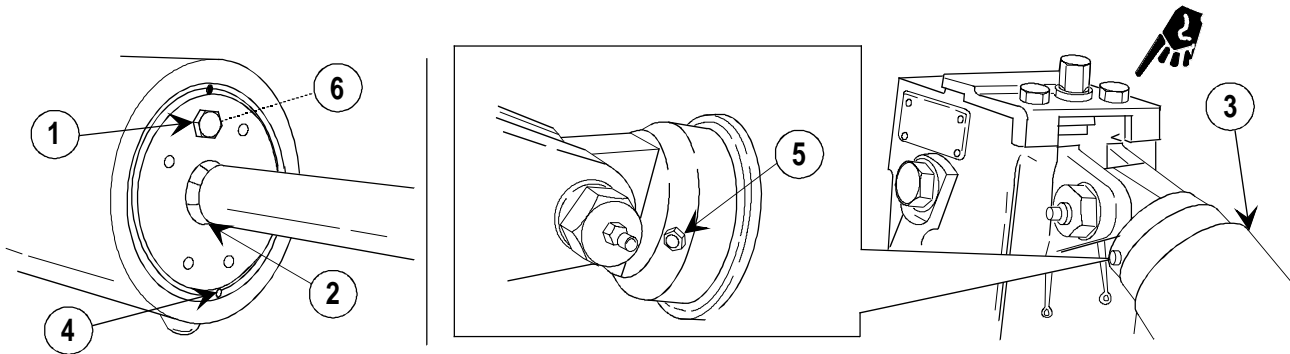

Step 6. After charging equilibrator assembly to pressure (p 2-151), check for leaks by applying soapy solution (item 30, appx B) to machine plug (1), around piston rod (2) at gland end, threaded ends of actuating cylinder (3) and end retainer (4), and to safety relief valve (5).

NOTE

Leaks at the threaded end, around piston rod, or a steady flow from safety relief valve, while the howitzer is in travel lock classify the equilibrator assembly as unserviceable. Identify location of leak and turn in the equilibrator assembly. If leak is from plug (1), replace packing (6) per TM 9-1025-211-20&P.

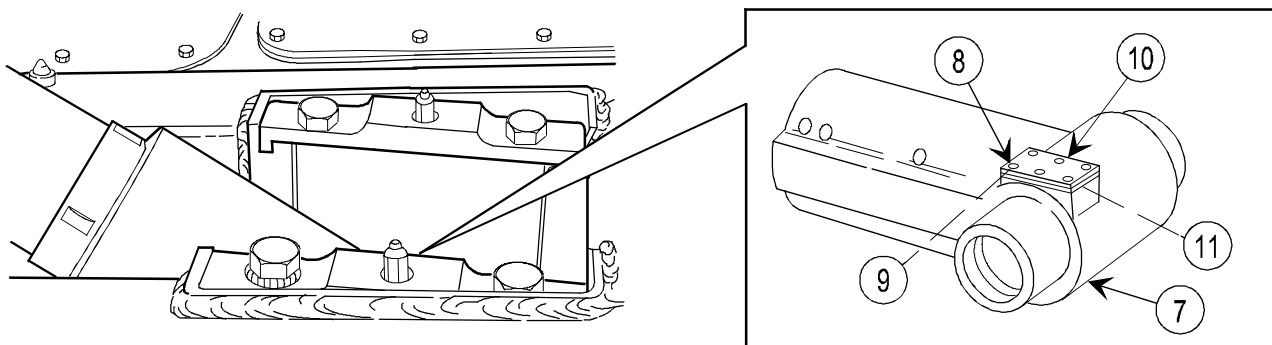

Step 7. In subfreezing temperatures, check housing (7) of both elevating screw assemblies for excess grease by placing howitzer in travel position and removing six machine screws (8), six lockwashers (9), access cover (10) and gasket (11).

Remove excess grease from housing.

2-4. TROUBLESHOOTING INFORMATION (cont)

Table 2-1. DIRECT SUPPORT TROUBLESHOOTING (cont)

MALFUNCTION	TEST OR INSPECTION	CORRECTIVE ACTION
-------------	--------------------	-------------------

ELEVATING MECHANISM (cont)

25. ELEVATING HANDWHEEL DIFFICULT TO TURN. (cont)

Step 8. Check for fully disengaged clutch by actuating manual release lever and turning elevating handwheel.

Check linkage for freedom of movement.

Step 9. Check variable recoil mechanism for proper adjustment of nonrotating eye bracket.

Refer to page 2-141.

TRAVERSING MECHANISM

26. PLAY IN TRAVERSING HANDWHEEL EXCEEDS 1/12 TURN (3-1/8 IN. (7.94 CM)).

Step 1. Check for stripped splines on traversing drive unit or traversing handwheel.

Replace worn or defective parts (p 2-221).

Step 2. Check for worn or broken universal joints.

Replace defective universal joints (p 2-221).

Step 3. Check for inoperative traversing angle drive unit.

Replace traversing angle drive unit (p 2-232).

Step 4. Check backlash of traversing angle drive unit.

Adjust backlash (p 2-232).

27. CANNON OVERTRAVELS WHEN TRAVERSING HANDWHEEL IS RELEASED.

Check for malfunctioning torque limiter.

Adjust torque limiter (p 2-227).

Table 2-1. DIRECT SUPPORT TROUBLESHOOTING (cont)

MALFUNCTION	TEST OR INSPECTION	CORRECTIVE ACTION
TOP CARRIAGE ASSEMBLY		
28. TOP CARRIAGE ASSEMBLY IS DIFFICULT TO TRAVERSE OR HAS UNEVEN OPERATION.		
Step 1.	Check for malfunctioning traversing angle drive unit.	Replace traversing angle drive unit (p 2-232).
Step 2.	Check for proper backlash adjustment.	Adjust backlash (p 2-232).
HYPAK SYSTEM		
28.1. WHEELS AND/OR SPEEDSHIFT FAIL TO RAISE OR LOWER.		
Step 1.	Perform an internal continuity check of the solenoid box.	<ul style="list-style-type: none">a. Open solenoid box per Paragraph 2-38.1.b. Disconnect splice halves (1 and 2) from each other.

2-4. TROUBLESHOOTING INFORMATION (cont)

Table 2-1. DIRECT SUPPORT TROUBLESHOOTING (cont)

MALFUNCTION	TEST OR INSPECTION	CORRECTIVE ACTION
-------------	--------------------	-------------------

HYPAK SYSTEM (cont)

28.1. WHEELS AND/OR SPEEDSHIFT FAIL TO RAISE OR LOWER. (cont)

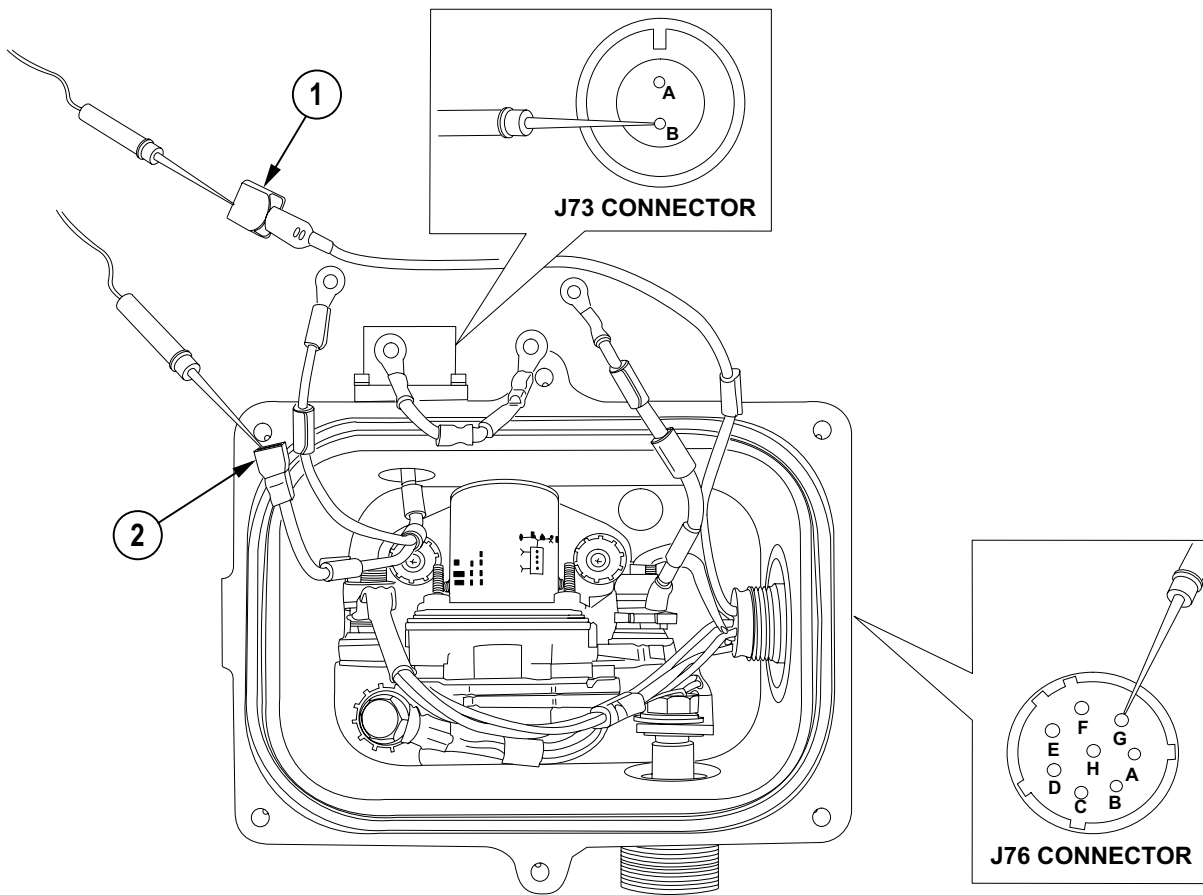

- c. Place one multimeter lead on J76 connector pin "G" and the other multimeter lead inside splice half (1).
- d. Place one multimeter lead on J73 connector pin "B" and the other multimeter lead inside splice half (2).

Table 2-1. DIRECT SUPPORT TROUBLESHOOTING (cont)

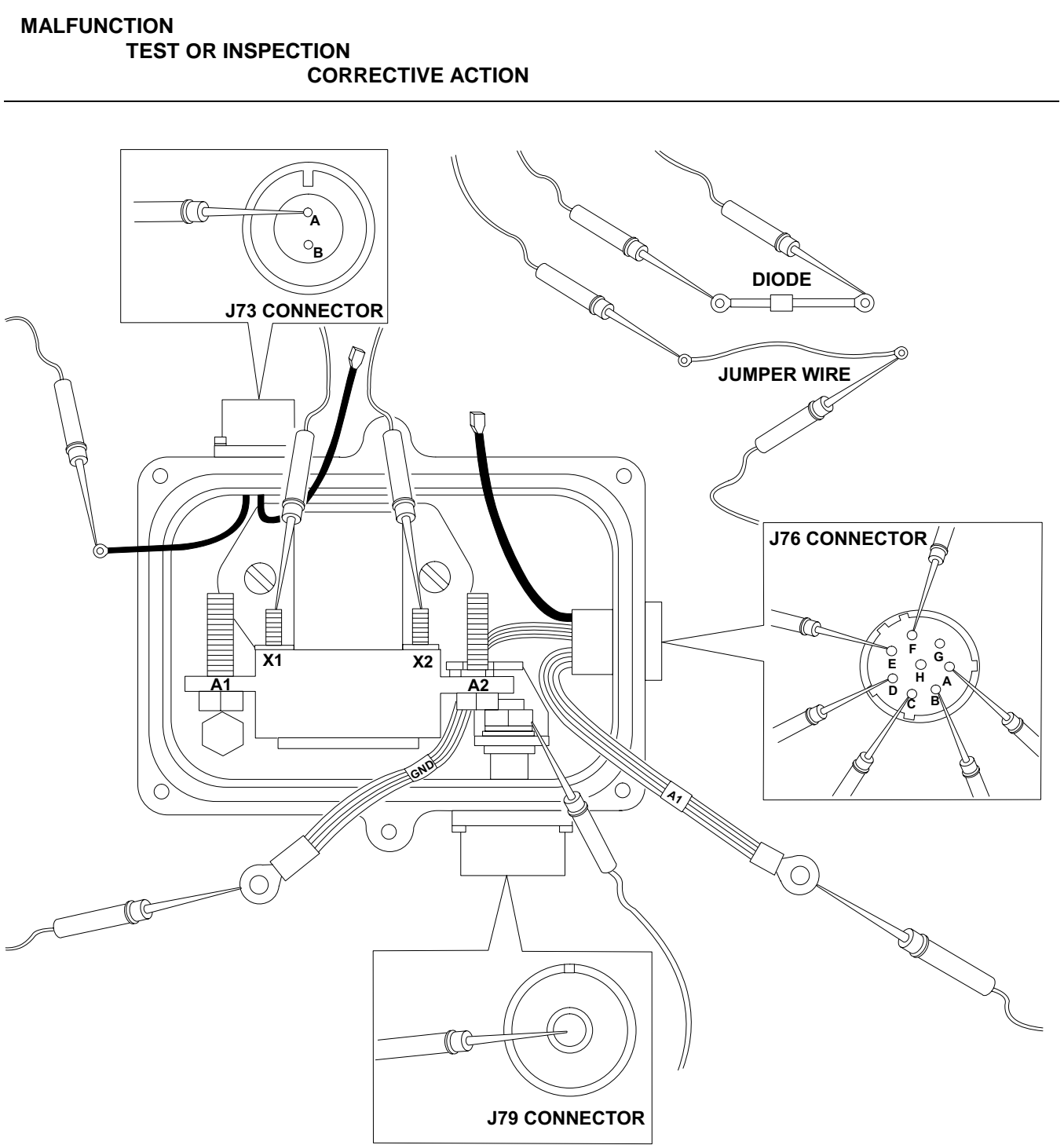

2-4. TROUBLESHOOTING INFORMATION (cont)

Table 2-1. DIRECT SUPPORT TROUBLESHOOTING (cont)

MALFUNCTION	TEST OR INSPECTION	CORRECTIVE ACTION
HYPAK SYSTEM (cont)		
28.1. WHEELS AND/OR SPEEDSHIFT FAIL TO RAISE OR LOWER. (cont)		
	e.	Disconnect all wires from connection points. Placing multimeter leads on referenced points of contact, check all wires/connectors for continuity in the following order. (1) J73 connector pin "A" to eyelet that was connected to relay coil stud. (2) J76 connector pins "A", "C", and "E" to eyelet on GND wire that was bolted to the inside of the box for ground. (3) J76 connector pins "F", "D", and "B" to eyelet on A1 wire that was connected to the relay coil stud. (4) J79 connector external post to internal stud. (5) Relay coil small stud "X1" to small stud "X2". NOTE For diode checks, select Diode mode on multimeter (if available). (6) Diode eyelet to diode eyelet. A two-way check is required. There should be no reading between eyelets in one direction; with multimeter leads switched, there should be a reading of 0.3 - 0.8. (7) Jumper wire eyelet to jumper wire eyelet. f. If any checks indicate no continuity or the diode does not read correctly, replace suspect cable assembly or defective item. g. Reconnect all cables and wires and attempt desired function. Listen for clicking sound coming from the solenoid box. <ul style="list-style-type: none">• If clicking sound is not heard, replace relay in solenoid box. See Paragraph 2-38.1.• If desired function does not occur and solenoid clicking sound is heard, proceed to Step 10.• If desired function occurs and solenoid clicking sound is heard, reassemble all components and continue with mission.

Table 2-1. DIRECT SUPPORT TROUBLESHOOTING (cont)

MALFUNCTION	TEST OR INSPECTION	CORRECTIVE ACTION
-------------	--------------------	-------------------

BOTTOM CARRIAGE ASSEMBLY

29. WHEELS WILL NOT MOVE UP OR DOWN.

Step 1. Check for engaged wheel lock handles.
Disengage wheel lock handles per TM 9-1025-211-10.

Step 2. Check for low oil level in manifold reservoir.
Refill hydraulic system per TM 9-1025-211-20&P.

Step 3. Check for broken rod end ball bearings on actuator cylinder assembly.
Replace rod end ball bearings (p 2-298).

Step 4. Visually check arm for cracks.
Replace arm (p 2-320).

Step 5. Check for broken hydraulic hoses in bottom carriage.
Replace broken hydraulic lines (p 2-271).

2-4. TROUBLESHOOTING INFORMATION (cont)

Table 2-1. DIRECT SUPPORT TROUBLESHOOTING (cont)

MALFUNCTION	TEST OR INSPECTION	CORRECTIVE ACTION
-------------	--------------------	-------------------

BOTTOM CARRIAGE ASSEMBLY (cont)

29. WHEELS WILL NOT MOVE UP OR DOWN. (cont)

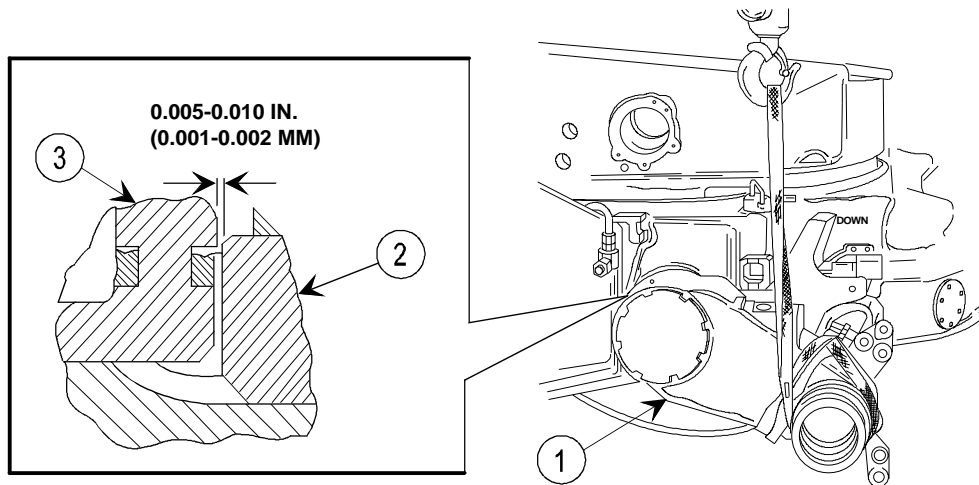

Step 6. Check for binding of axle (1) and bottom carriage assembly. Indications are loud popping, cracking, or grinding noises, or failure to completely raise howitzer to the towed position.

Lubricate in accordance with TM 9-1025-211-10, appx F repeatedly while attempting to raise and lower the wheels.

Step 7. Check for required clearance of 0.005 to 0.010 in. (0.001 to 0.002 mm) between wheel arm-and-spindle assemblies (2) and sleeve bushings (3). Adjust clearance if required (p 2-320).

Lubricate in accordance with TM 9-1025-211-10, appx F.

Step 8. Check for inoperative check valves in manifold assembly. Visually inspect for broken spring or piece of debris caught in check valves.

Replace check valves (p 2-271).

30. WHEELS WOBBLE.

Step 1. Check for loose wheel retaining nuts.

Torque wheel retaining nuts to 450.0 ft-lb (607.5 N-m).

Table 2-1. DIRECT SUPPORT TROUBLESHOOTING (cont)

MALFUNCTION	TEST OR INSPECTION	CORRECTIVE ACTION
	Step 2.	Check for damaged wheels or hub. Replace damaged parts (TM 9-1025-211-20&P).
	Step 3.	Check for loose wheel bearings. Adjust or replace wheel bearings (TM 9-1025-211-20&P).
31. SPEED SHIFT ASSEMBLY CANNOT BE EXTENDED OR RETRACTED.		
	Step 1.	Check for broken hydraulic hoses. Replace broken hydraulic hoses (p 2-271).
	Step 2.	Check for inoperative check valves in manifold assembly by visually inspecting for broken spring or piece of debris caught in check valves. Replace check valves (p 2-271).
	Step 3.	Check pressure of master bypass valve with fabricated gauge (Figure C-21, appx C). Replace master bypass valve (p 2-271).
32. HANDBRAKES FAIL TO HOLD IN PARK POSITION.		
	Step 1.	Check for improper brake adjustment. Adjust brakes (p 2-308).
	Step 2.	Check for worn brake assembly parts. Replace worn parts as required (p 2-308).
33. AIR BRAKES ARE LOCKED. (FOR UNMODIFIED HOWITZER, POWER BOOSTER PIN IS EXTENDED. FOR MODIFIED HOWITZER, GAGES INDICATE PRESSURE APPLIED.)		
	Step 1.	Check for crossed emergency and service hose assemblies. Hook up emergency and service hose assemblies correctly per TM 9-1025-211-10. (For modified howitzers, refer to hose hookup instruction plate on cannon tube travel lock.)
	Step 2.	Check for adequate air source at prime mover. Check prime mover TM. Prime mover requires 90 psi (621 kPa) of air.
	Step 3.	Service and emergency air line cutout cocks in prime mover not fully opened.

2-4. TROUBLESHOOTING INFORMATION (cont)

Table 2-1. DIRECT SUPPORT TROUBLESHOOTING (cont)

MALFUNCTION	TEST OR INSPECTION	CORRECTIVE ACTION
-------------	--------------------	-------------------

BOTTOM CARRIAGE ASSEMBLY (cont)

33. AIR BRAKES ARE LOCKED. (FOR UNMODIFIED HOWITZER, POWER BOOSTER PIN IS EXTENDED. FOR MODIFIED HOWITZER, GAGES INDICATE PRESSURE APPLIED.) (cont)

Fully open service and emergency air line cutout cocks on prime mover per TM 9-1025-211-10.

Step 4. Check for air leak at pipe plug in brake system (emergency).

Repair air leak per TM 9-1025-211-20&P.

34. AIR BRAKES ARE WEAK.

Step 1. Check for air in brake system oil.

Purge brake head assembly per TM 9-1025-211-20&P.

Step 2. Check for adequate air source at prime mover.

Refer to corrective procedure for prime mover.

Step 3. Check for dirty fluid filter element in brake line air filter.

Clean in accordance with TM 9-1025-211-20&P.

Step 4. Check for brake carrier and liner assemblies worn past the grooves.

Replace as required (p 2-314).

Step 5. Check that disk is not worn below 0.450 in. (1.141 cm) or damaged beyond use.

Replace as required (p 2-320).

Step 6. Check for low brake fluid level in hydraulic reservoir.

Fill reservoir per TM 9-1025-211-20&P.

34.1. LIGHTS IN VEHICULAR TAILLIGHT DO NOT ILLUMINATE.

Step 1. Perform basic electrical check to test performance of lights.

a. Connect vehicular taillight to a towing vehicle with an electrical system known to be functional, using a cable assembly 12009266 known to be functional.

Table 2-1. DIRECT SUPPORT TROUBLESHOOTING (cont)

MALFUNCTION	TEST OR INSPECTION	CORRECTIVE ACTION
-------------	--------------------	-------------------

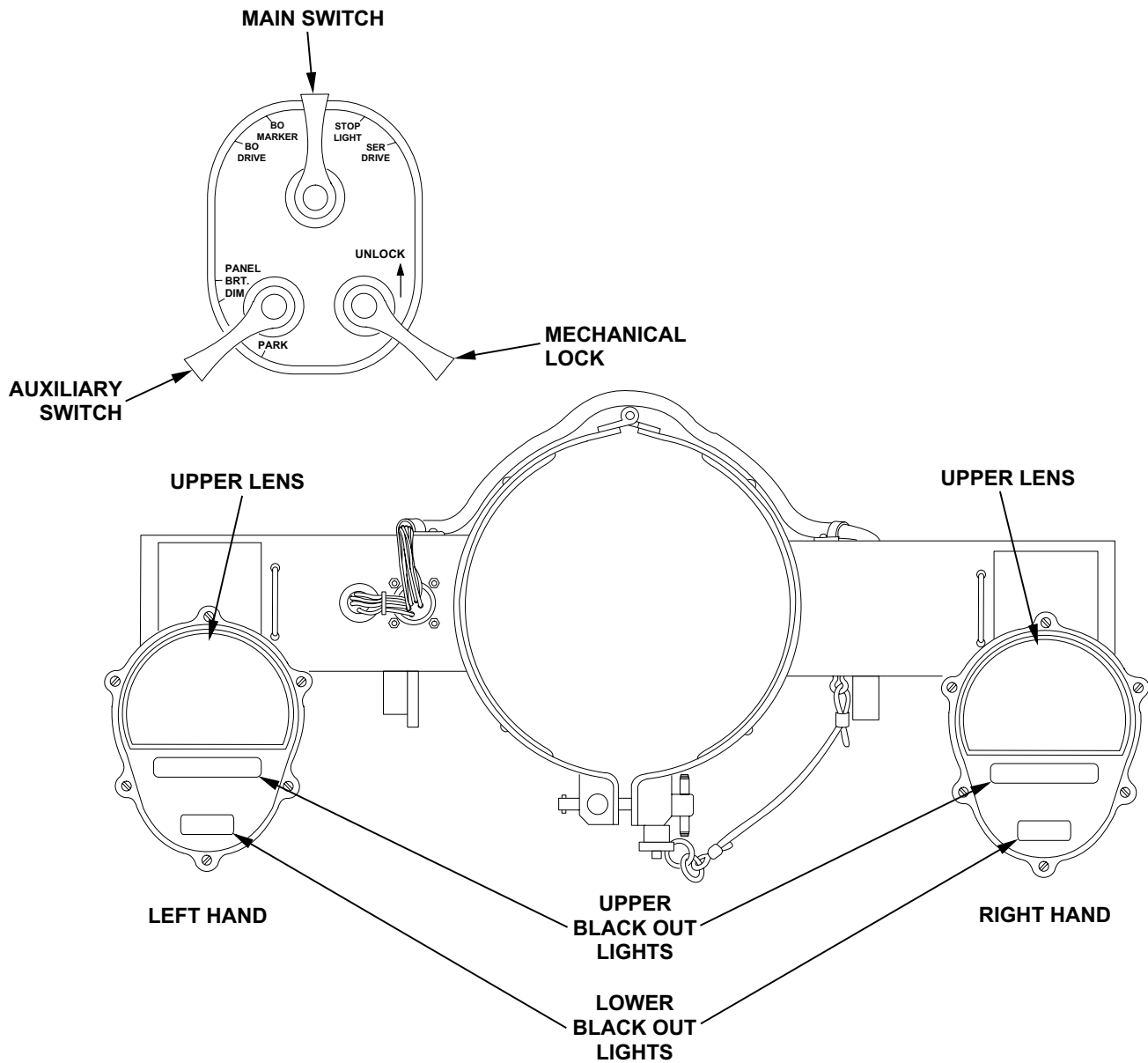

- b. Turn vehicle's light switch to the "SER DRIVE" position and perform following checks.
 - (1) Check to see if upper red lenses in both light assemblies are illuminated.
 - (2) Apply pressure to brake pedal, as if stopping the vehicle, and see if upper lenses become brighter.

2-4. TROUBLESHOOTING INFORMATION (cont)

Table 2-1. DIRECT SUPPORT TROUBLESHOOTING (cont)

MALFUNCTION	TEST OR INSPECTION	CORRECTIVE ACTION
-------------	--------------------	-------------------

BOTTOM CARRIAGE ASSEMBLY (cont)

34.1. LIGHTS IN VEHICULAR TAILLIGHT DO NOT ILLUMINATE. (cont)

- (3) Position vehicle's turn signal control to both the left and right positions. Upper lenses should illuminate in relationship with direction of turn signal control lever.
- c. Turn vehicle's light switch to the "STOP LIGHT" position and perform following checks.
 - (1) Upper lens should not be illuminated.
 - (2) Apply pressure to brake pedal, as if stopping the vehicle; upper lens should illuminate.
 - (3) Position vehicle's turn signal control to both the left and right positions. Upper lenses should illuminate in relationship with direction of turn signal control lever.
- d. Turn vehicle's light switch to the "BO MARKER" position and perform following checks.
 - (1) Upper lens should not be illuminated.
 - (2) Upper Black Out lights should be illuminated.
 - (3) Apply pressure to brake pedal, as if stopping the vehicle; lower Black Out lights should illuminate.
 - (4) There is no Turn Signal test.
- e. Turn vehicle's light switch to the "BO DRIVE" position and perform following checks.
 - (1) Upper lens should not be illuminated.
 - (2) Upper Black Out lights should be illuminated.
 - (3) Apply pressure to brake pedal, as if stopping the vehicle; lower Black Out lights should illuminate.
 - (4) There is no Turn Signal test.
 - If all lights performed properly, proceed to Step 2.
 - If lights failed performance test, proceed to Step 4.

Table 2-1. DIRECT SUPPORT TROUBLESHOOTING (cont)

MALFUNCTION	TEST OR INSPECTION	CORRECTIVE ACTION
	Step 2.	<p>Reconnect original cable assembly between replacement towing vehicle and vehicular taillight. Attempt tests in Steps 1b through 1e.</p> <ul style="list-style-type: none"> • If all lights performed properly, refer to vehicle technical manual for electrical system troubleshooting procedures. • If lights failed performance test, proceed to Step 3.
	Step 3.	<p>Check original cable assembly for damage, perform continuity check, and replace cable if necessary. Attempt tests in Steps 1b through 1e.</p> <ul style="list-style-type: none"> • If all lights performed properly, return to service. • If lights failed performance test, proceed to Step 4.
	Step 4.	<p>Check function of stoplight-taillight assemblies.</p>

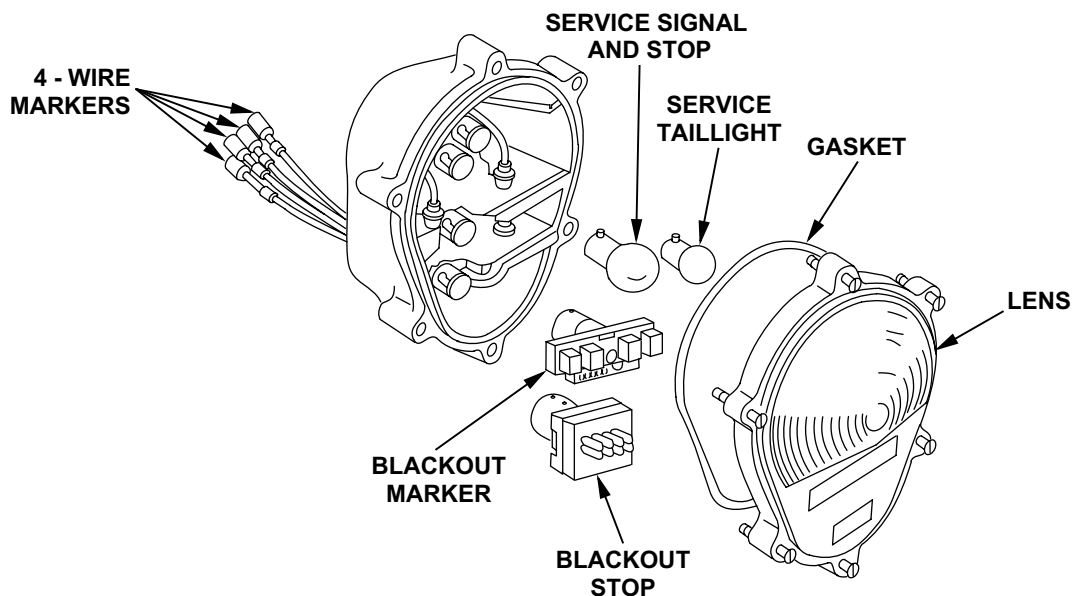

- a. Remove lens and gasket to gain access to lamps. Refer to TM 9-1025-211-20&P.

NOTE

Continuity checks performed on light-emitting diode (LED) lamps need to be checked in both directions. There should be no continuity indicated in one direction; continuity should be indicated with multimeter leads placed in other direction.

- b. Remove suspect lamps and conduct continuity check on them. Replace any lamp that does not pass the continuity check.
- c. Clean all moisture and debris from inside of assemblies.

2-4. TROUBLESHOOTING INFORMATION (cont)

Table 2-1. DIRECT SUPPORT TROUBLESHOOTING (cont)

MALFUNCTION	TEST OR INSPECTION	CORRECTIVE ACTION
-------------	--------------------	-------------------

BOTTOM CARRIAGE ASSEMBLY (cont)

34.1. LIGHTS IN VEHICULAR TAILLIGHT DO NOT ILLUMINATE. (cont)

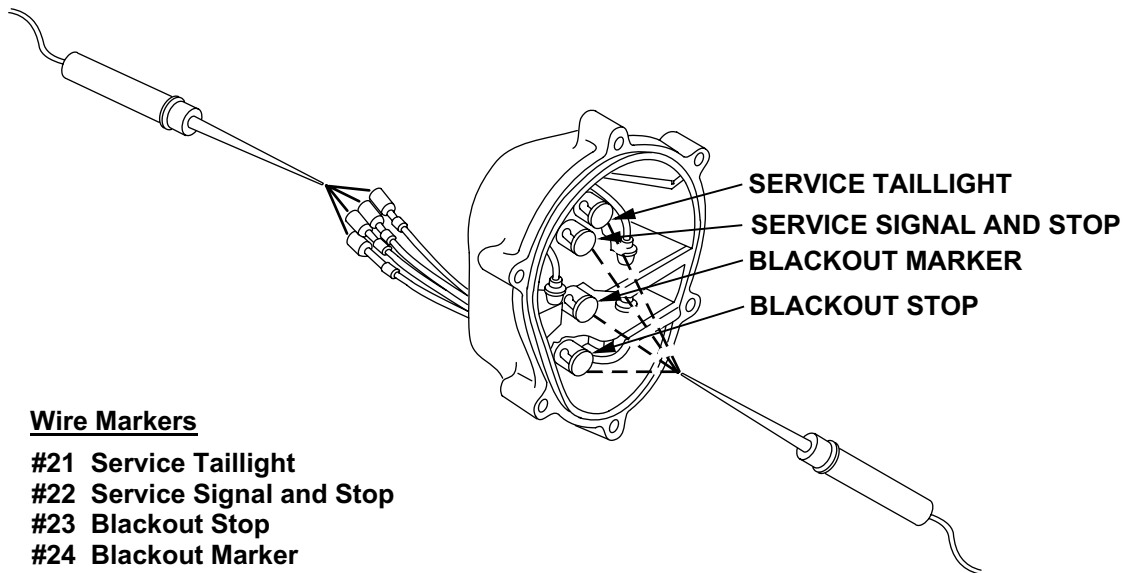

Wire Markers

- #21 Service Taillight
- #22 Service Signal and Stop
- #23 Blackout Stop
- #24 Blackout Marker

d. Conduct continuity check on suspect stoplight-taillight assemblies. Place one multimeter lead inside lamp socket and other multimeter lead on corresponding wire lead coming from back of assembly. Perform check in order listed. Replace stoplight-taillight assembly if any of the tests indicate no continuity.

Wire Markers	To	Lamp Socket
#21	to	Service taillight (top socket)
#22	to	Service signal and stop (second socket from top)
#23	to	Blackout Stop (bottom socket)
#24	to	Blackout Marker (second socket from bottom)
Ground (i.e. mounting bolt)	to	Outer surface of lamp sockets

- e. Reconnect wire leads of stoplight-taillight assembly to wiring harness leads. Attempt tests in Steps 1b through 1e.
- If lights performed properly, return to service.
 - If lights failed performance test, proceed to Step 5.

Table 2-1. DIRECT SUPPORT TROUBLESHOOTING (cont)

MALFUNCTION	TEST OR INSPECTION	CORRECTIVE ACTION
-------------	--------------------	-------------------

Step 5. Check for continuity in electrical lead assembly.

- a. Disconnect cable assembly 12009266 from vehicular taillight to gain access to pins in electrical lead assembly connector.

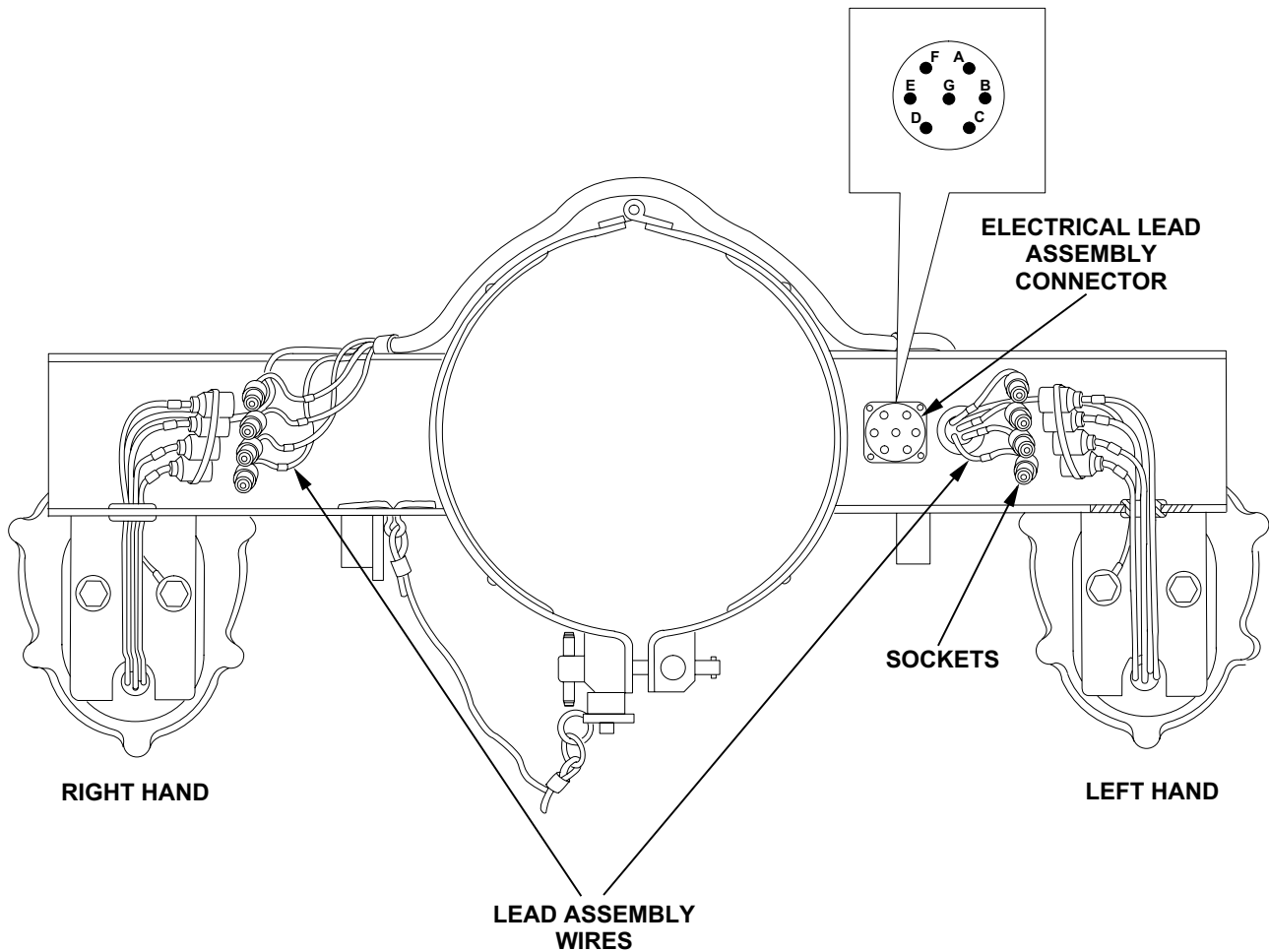

- b. Disconnect four lead assembly wires from suspect stoplight-taillight assembly to gain access to the electrical lead assembly connector pins.

2-4. TROUBLESHOOTING INFORMATION (cont)

Table 2-1. DIRECT SUPPORT TROUBLESHOOTING (cont)

MALFUNCTION	TEST OR INSPECTION	CORRECTIVE ACTION
-------------	--------------------	-------------------

BOTTOM CARRIAGE ASSEMBLY (cont)

34.1. LIGHTS IN VEHICULAR TAILLIGHT DO NOT ILLUMINATE. (cont)

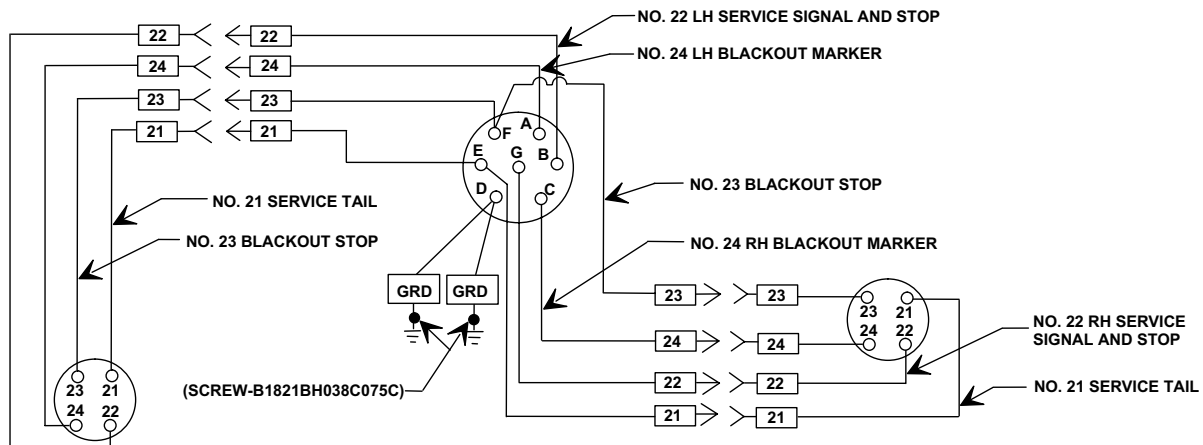

WIRING DIAGRAM

- c. Conduct continuity check on electrical lead assembly. Perform check in order listed. Replace electrical lead assembly if any of the tests indicate no continuity.

Multimeter Lead #1 on Connector Pins	To	Multimeter Lead #2
D	to	Mounting bolts on both taillight assemblies that are not retaining the ground wire. Ensure a clean metal contact is made.
A	to	Left Hand Lead Assy. socket labeled #24
B	to	Left Hand Lead Assy. socket labeled #22
C	to	Right Hand Lead Assy. socket labeled #24
E	to	Both sides Lead Assy. sockets labeled #21
F	to	Both sides Lead Assy. sockets labeled #23
G	to	Right Hand Lead Assy. socket labeled #22

- d. Reconnect lead assembly wires. Attempt tests in Steps 1b through 1e.
 - If lights performed properly, return to service.

Table 2-1. DIRECT SUPPORT TROUBLESHOOTING (cont)

MALFUNCTION	TEST OR INSPECTION	CORRECTIVE ACTION
NITROGEN HOSE ASSEMBLY		
35. NITROGEN HOSE ASSEMBLY WILL NOT HOLD NITROGEN UNDER PRESSURE.		
Step 1.	Check for loose fittings.	Tighten fittings.
Step 2.	Check for missing or damaged valve core from valve assembly.	Replace valve assembly (p 2-387).
AMMUNITION LOADING TRAY		
36. AMMUNITION LOADING TRAY IS DEFECTIVE.		
	Check for loose, broken, or missing stop.	Repair by replacement of rivets or stop as required (p 2-391).
NITROGEN CHARGING KIT		
37. NITROGEN CHARGING KIT IS INCOMPLETE.		
	Check for missing parts.	Replace missing parts (2-392).
NITROGEN CHARGING ASSEMBLY		
38. 4000-LB GAGE DOES NOT FUNCTION.		
Step 1.	Check for pressure in nitrogen tank.	Replace empty nitrogen tank per TM 9-1025-211-20&P.
Step 2.	Check for defective 4000-lb gage.	Replace regulator (p 2-392).
39. 3000-LB GAGE DOES NOT FUNCTION.		
Step 1.	Check that regulator handle is open (turned clockwise).	Turn regulator handle clockwise.
Step 2.	Check for defective 3000-lb gage.	Replace regulator (p 2-392).

2-4. TROUBLESHOOTING INFORMATION (cont)

Table 2-1. DIRECT SUPPORT TROUBLESHOOTING (cont)

MALFUNCTION	TEST OR INSPECTION	CORRECTIVE ACTION
-------------	--------------------	-------------------

NITROGEN CHARGING ASSEMBLY (cont)

40. CHARGING PRESSURE CANNOT BE OBTAINED.

Step 1. Check that nitrogen tank pressure is at or above charging pressure.

Replace nitrogen tank per TM 9-1025-211-20&P.

Step 2. Check that regulator handle is open.

a. Turn regulator handle clockwise.

b. Replace regulator (defective diaphragm) (p 2-392).

AIR PRESSURE GAGE ASSEMBLY

41. PRESSURE GAGE DOES NOT REGISTER READING WHEN CHECKING EQUILIBRATOR CYLINDERS.

Step 1. Check that valve core release handle on valve is in open position.

a. Turn valve core release handle clockwise.

b. Replace hose assembly if pressure does not register.

Step 2. Check that pressure gage is not broken or inoperative.

Replace air pressure gage assembly (p 2-393).

Section III. M199 CANNON MAINTENANCE INSTRUCTIONS

Section Index

Paragraph		Page
2-5.	General Maintenance Instructions.....	2-23
2-6.	M199 Cannon—Maintenance Instructions	2-23
2-7.	Thermal Warning Device—Maintenance Instructions	2-35
2-8.	Cannon Tube—Maintenance Instructions	2-42
2-9.	Breech Mechanism Assembly—Maintenance Instructions	2-49

2-5. GENERAL MAINTENANCE INSTRUCTIONS

WARNING

Stand clear of hoisted components or injury to personnel may result.

- a. Before performing any of the maintenance procedures, make sure that the brakes are engaged.
- b. Clean all metal parts during maintenance with wiping rags (item 22, appx B) and cleaning compound (item 7, appx B).
- c. Lubricate mating surfaces and gears with WTR (item 11, appx B).

WARNING

Dry cleaning solvent is flammable and should not be used near an open flame or in a smoking area. Use only in well-ventilated areas. This solvent evaporates quickly and has a drying effect on the skin. When used without gloves, it may cause cracks in the skin and, in some cases, mild irritation or inflammation.

- d. Clean all gears with cleaning compound (item 7, appx B), unless otherwise specified.

2-6. M199 CANNON—MAINTENANCE INSTRUCTIONS

THIS TASK COVERS:

- | | | | |
|------------|----------------------|------------|-----------------|
| a. Removal | b. Inspection/repair | c. Service | d. Installation |
|------------|----------------------|------------|-----------------|

INITIAL SETUP

Tools and Special Tools

- Artillery and turret mechanic's ordnance tool kit (SC 5180-95-CL-A12)
- Artillery field maintenance shop equipment (SC 4933-95-CL-A12)
- Gun tube slings (8735439 or 8735440)
- M198 repairman field artillery tool kit (5911278)
- Safety strut assembly (2) (12008900)
- 3-ton hoist available

2-6. M199 CANNON—MAINTENANCE INSTRUCTIONS (cont)

Materials/Parts

- Cleaning compound (item 7, appx B)
- Lock wire (item 34, appx B)
- Lock wire (item 39, appx B)
- WTR grease (item 11, appx B)

Personnel Required: 2

Artillery repairmen to lift heavy parts and operate cannon tube and hoist

References

- TM 9-1025-211-10
- TM 9-1025-211-20&P
- TM 9-1025-211-34P

Equipment Conditions

- Trails spread and locked into position (TM 9-1025-211-10)
- Travel lock assembly disconnected from bottom carriage assembly and connected to cradle assembly (TM 9-1025-211-10)
- Howitzer lowered onto firing assembly baseplate (TM 9-1025-211-10) and lowered to zero elevation
- Muzzle brake removed (TM 9-1025-211-20&P)

General Safety Instructions

WARNING

All lifting devices must be checked in accordance with local Standing Operating Procedure (SOP) to make sure they are in good working condition before starting the lifting operation.

REMOVAL

- 1 Remove lock wire, eight capscrews (1), and eight lockwashers (2).
- 2 Remove recoil mechanism ballistic shield (3).

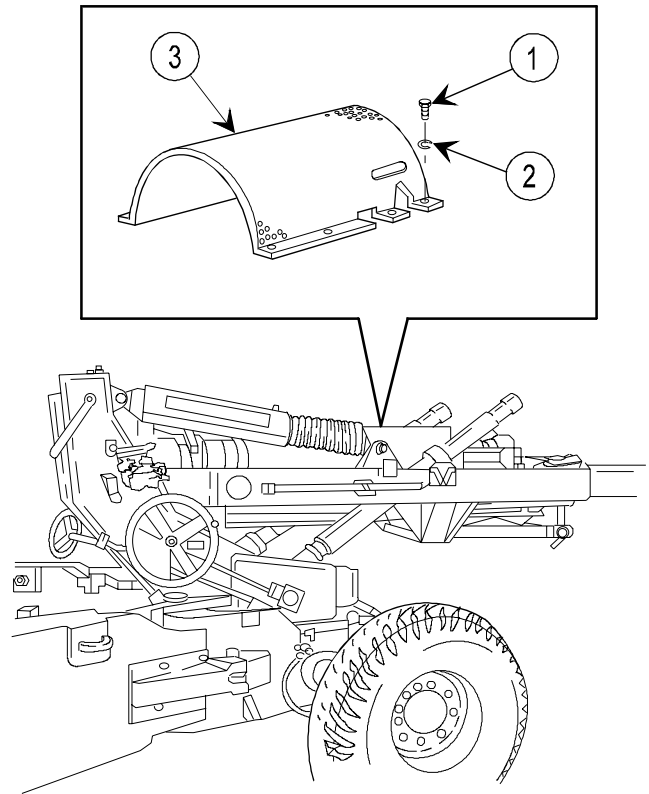

WARNING

Install safety strut assemblies to prevent injury to personnel or damage to equipment.

- 3 To attach two safety strut assemblies (4):
 - a. Remove four nuts (5), four washers (6), and four screws (7) from each strut.
 - b. Remove two top caps (8).
 - c. Place lower halves around bar on cradle assembly (9) and install top caps (8), screws (7), washers (6), and nuts (5). Tighten nuts.
 - d. Attach two safety strut assemblies (4) to bottom carriage assembly (10) using pin (11), and install safety pin (12).

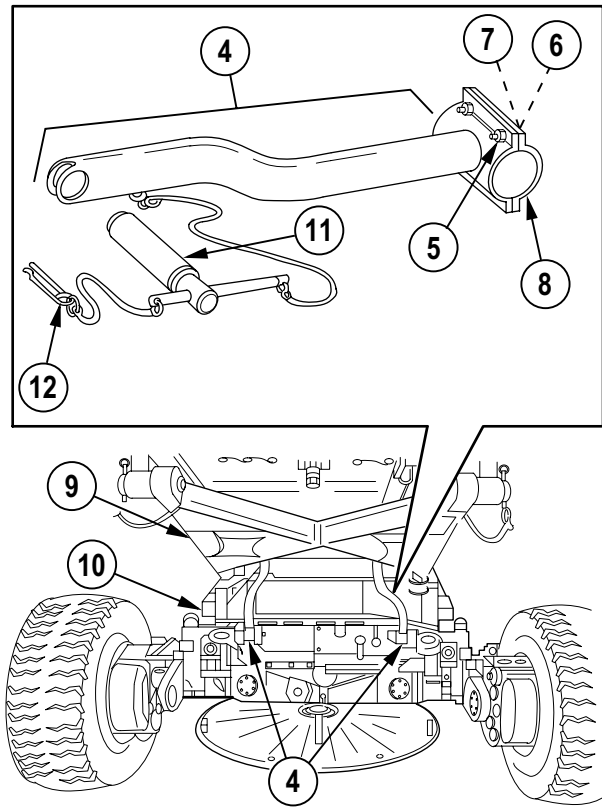

4 Deleted.

5 Remove four hose clamps (16).

6 Remove barrel clamp (17).

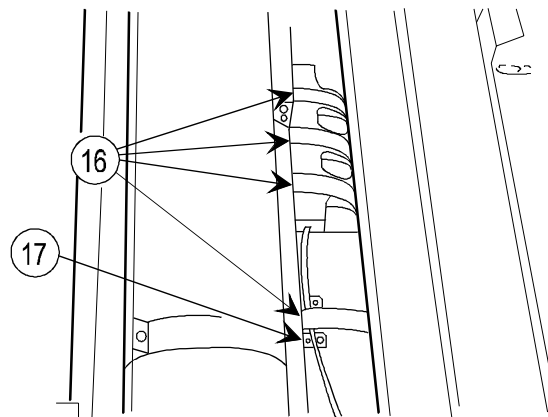

2-6. M199 CANNON—MAINTENANCE INSTRUCTIONS (cont)

REMOVAL (cont)

CAUTION

Lift housing assembly and thermal warning device at the same time when steps 7 and 8 are performed. Moving either part by itself can damage the capillary tube.

NOTE

Do not attempt to separate housing assembly from sensing bulb at this time.

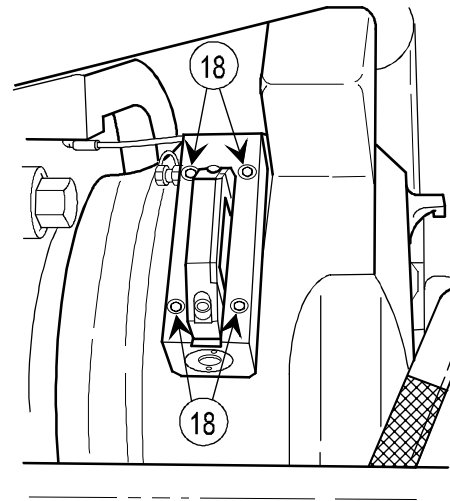

7 Remove four screws (18).

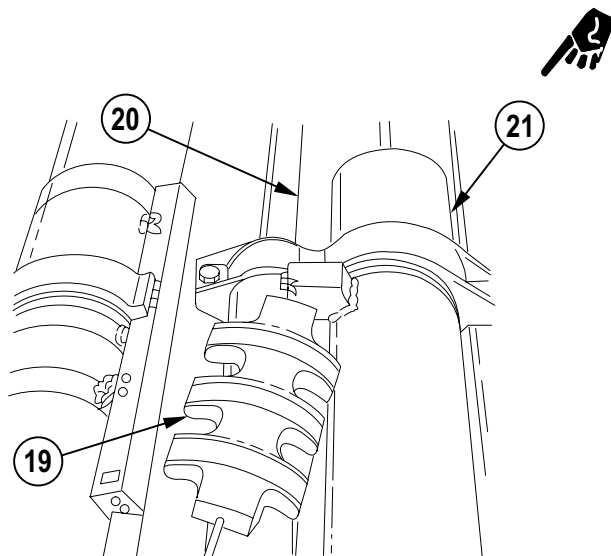

8 Lift housing assembly (19) from cannon tube (20) and place on recoil mechanism (21). Remove thermal warning device (22), and secure to recoil crossover cover (21.1).

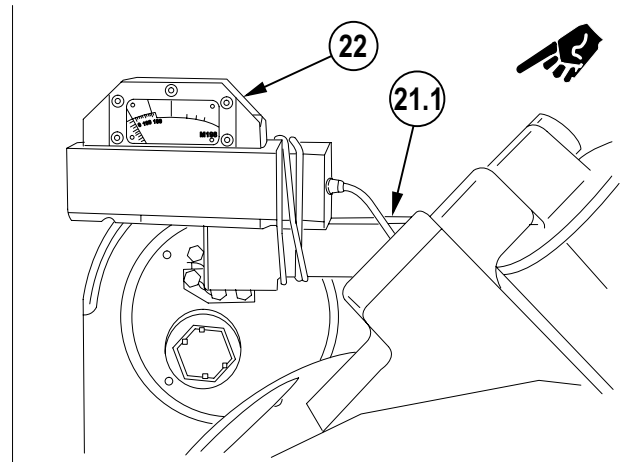

9 Remove lock wire (item 39, appx B) from capscrew (23) on breech mechanism assembly (24).

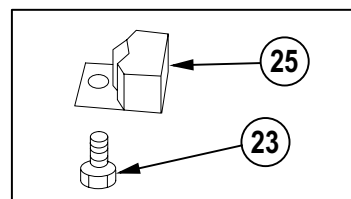

10 Remove capscrew (23) and torque key (25) from breech mechanism assembly (24).

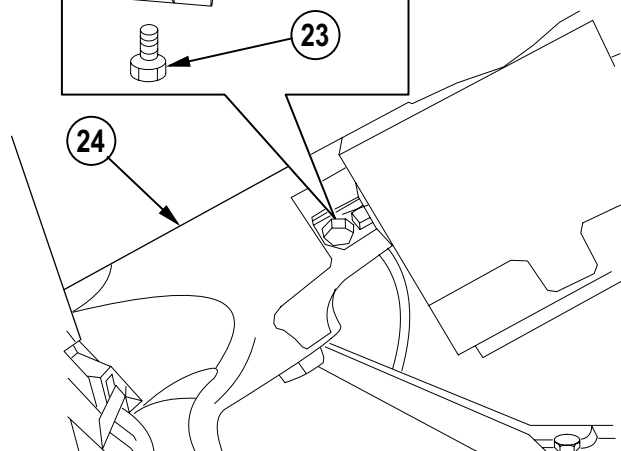

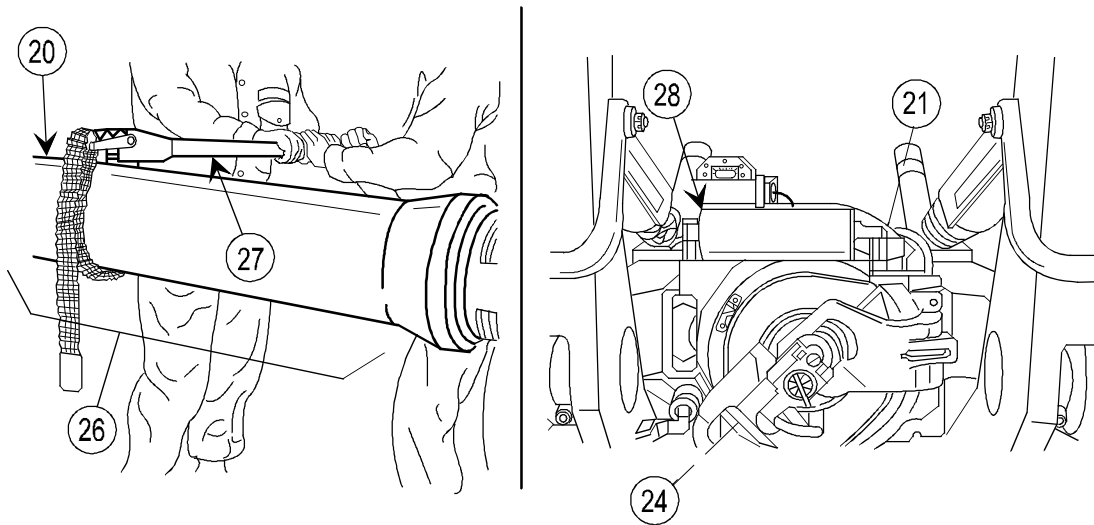

CAUTION

When removing M199 cannon (26), maintain control and balance of the cannon to avoid damage to the M39 carriage and cannon components.

- 11 Position tube wrench (27) midway between machined surface and muzzle end of cannon tube (20).
- 12 Rotate cannon tube (20) 1/8 turn clockwise as viewed from the muzzle end (until breech counterbalance (28) is level) to disengage interrupted threads of breech mechanism assembly (24) from interrupted threads of recoil mechanism (21).

- 13 Loop cannon tube sling (29) around front end of cannon tube (20). Hook to mechanical puller (30), and position other chain end of mechanical puller on clevis assembly (31).
- 14 Using mechanical puller (30), move cannon tube (20) rearward out of cradle assembly (9) approximately 2 ft (0.6 m).
- 15 Unhook cannon tube sling (29) and mechanical puller (30).

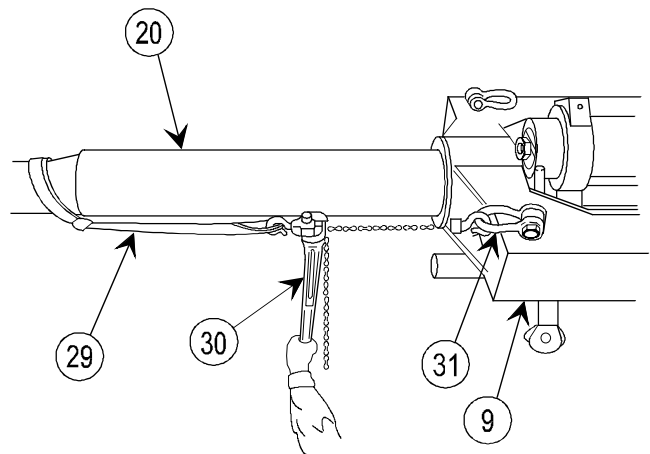

2-6. M199 CANNON—MAINTENANCE INSTRUCTIONS (cont)

REMOVAL (cont)

NOTE

A 3-ton gun tube sling (32) and hoist (33) must be used to perform the following operation.

- 16 Position gun tube sling (32) around cannon tube in front of breech mechanism assembly (24) and attach gun tube sling (32) to hoist (33).

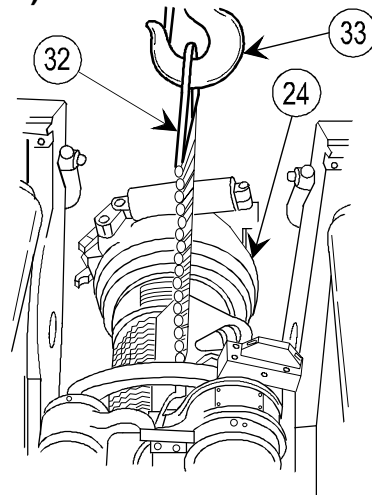

- 17 Insert timber (34) into muzzle end of cannon tube (20), and guide cannon tube through cradle assembly (9).

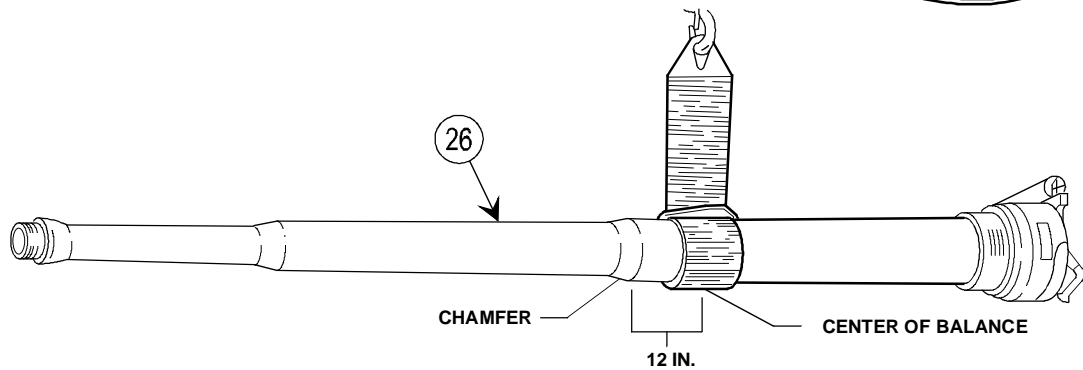
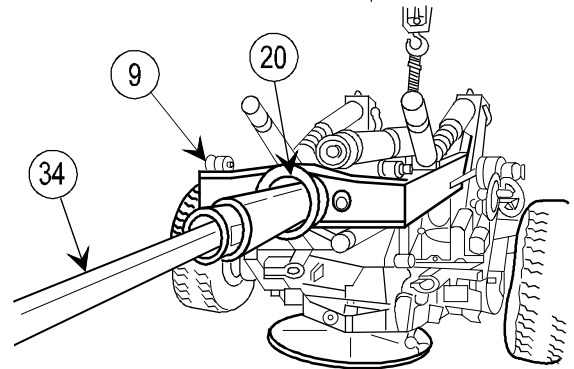

NOTE

Center of sling should be 12.0 in. (30.5 cm) behind the chamfer on the largest diameter of cannon tube.

- 18 Move M199 cannon (26) rearward to reach center line of balance point.
- 19 Support breech end with suitable support (35) prior to releasing tension on gun tube sling (32).

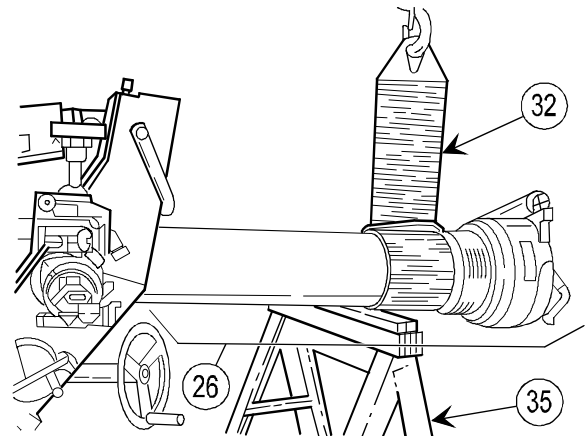

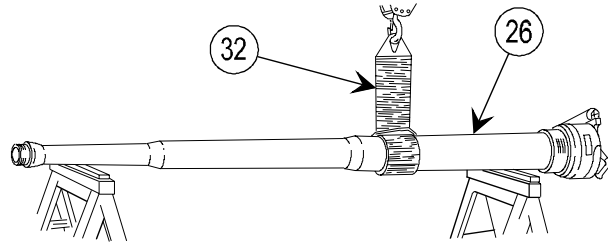
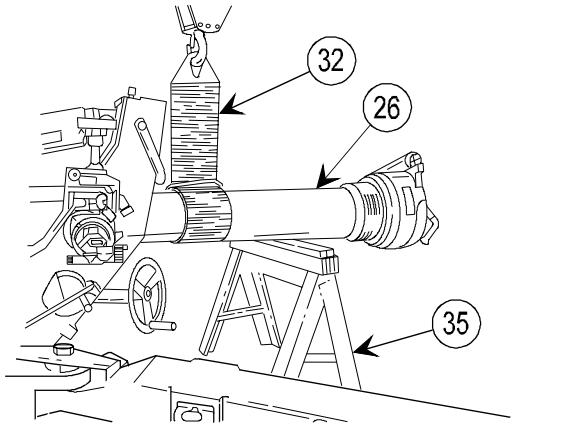

NOTE

Timbers may be used as supports.

- 20 Slide gun tube sling (32) to center of balance.
- 21 Remove M199 cannon support (35) from breech end.

- 22 Carefully pull M199 cannon (26) rearward and lower onto suitable support.
- 23 Remove gun tube sling (32).

INSPECTION/REPAIR

- 1 Check for broken, damaged, or missing parts.
- 2 Repair is by replacement of authorized parts (TM 9-1025-211-34P).

SERVICE

Clean threads on M199 cannon with cleaning compound and lubricate with WTR grease. Clean mating threads on rear yoke with cleaning compound and lubricate with WTR grease.

INSTALLATION

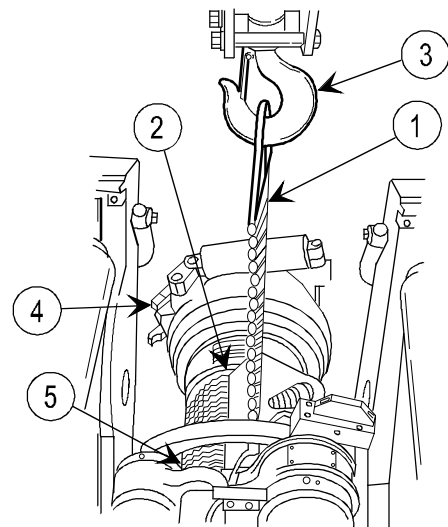
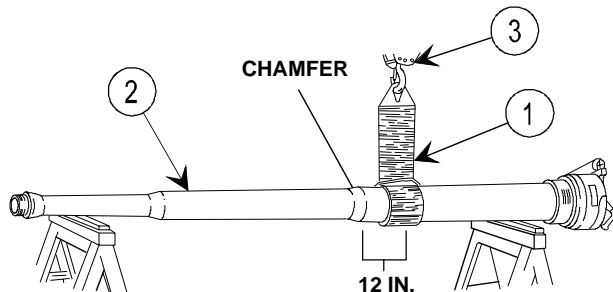

- 1 Install gun tube sling (1) around cannon tube (2) on center of balance and hook to hoist (3).

- 2 Lift M199 cannon (4) and slide it into recoil mechanism (5) as far as possible.

2-6. M199 CANNON—MAINTENANCE INSTRUCTIONS (cont)

INSTALLATION (cont)

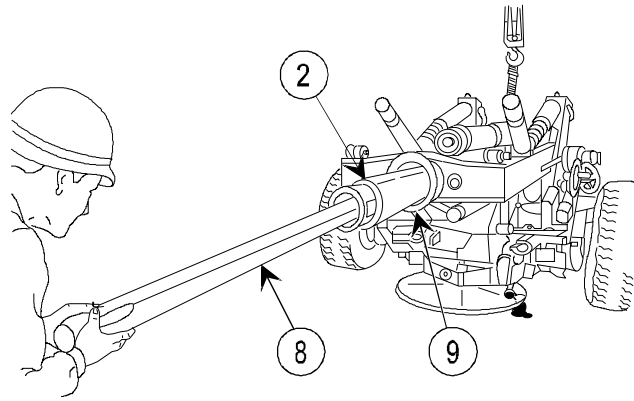
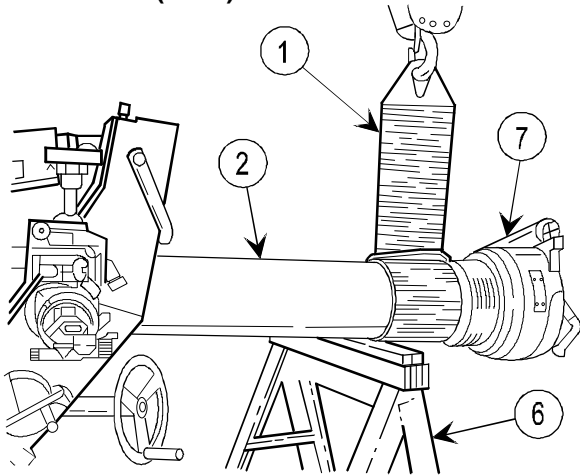

- 3 Support breech end with suitable support (6).
- 4 Reposition gun tube sling (1) around cannon tube (2) just forward of breech mechanism assembly (7).
- 5 Insert timber (8) into muzzle end of cannon tube (2), and guide through cradle assembly (9).
- 6 Lift and slide M199 cannon (4) into cradle assembly (9) until approximately 2 ft (0.6 m) out of battery.
- 7 Unhook gun tube sling (1) from hoist (3) and cannon tube (2).

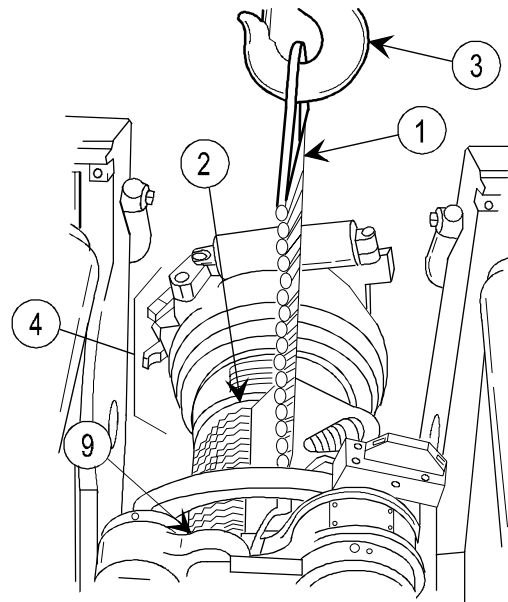

- 8 Attach gun tube sling (10) to breech mechanism assembly (7).

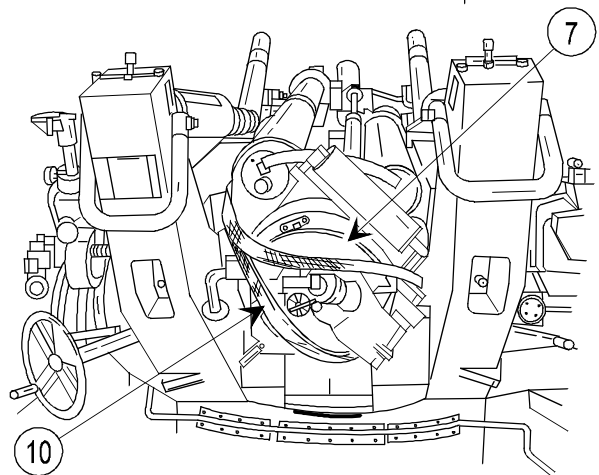

- 9 Hook gun tube sling (10) to mechanical puller (11), and attach other end of mechanical puller (11) to left front clevis assembly (12).

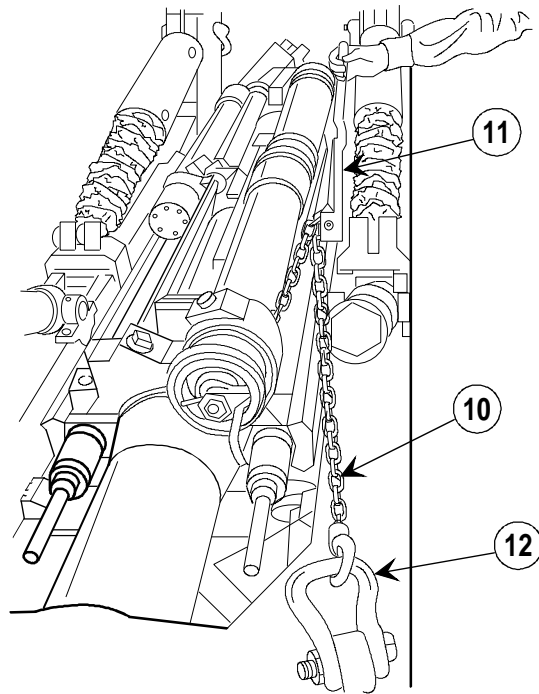

NOTE

The M199 cannon (4) must be positioned so breech counterbalance (13) is level to engage interrupted threads of breech mechanism assembly (7) with interrupted threads of recoil mechanism (5).

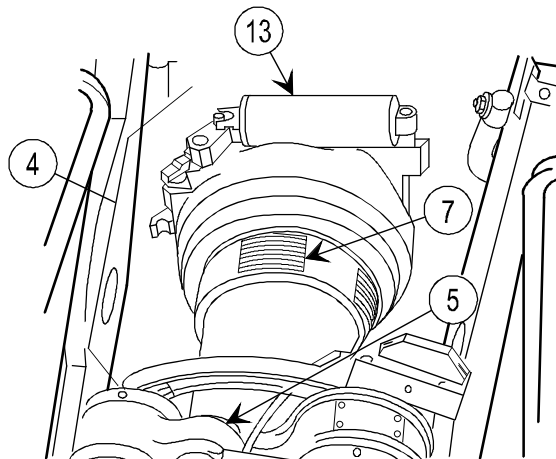

- 10 Work mechanical puller (11) until breech mechanism assembly (7) is within 1/16 in. (0.16 cm) of recoil mechanism (5).

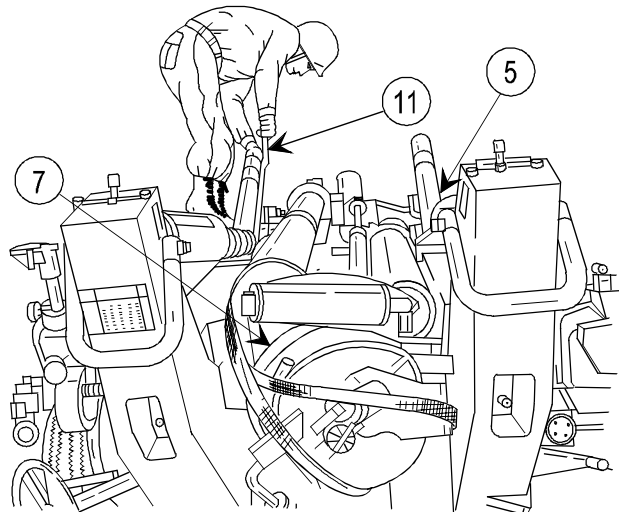

2-6. M199 CANNON—MAINTENANCE INSTRUCTIONS (cont)

INSTALLATION (cont)

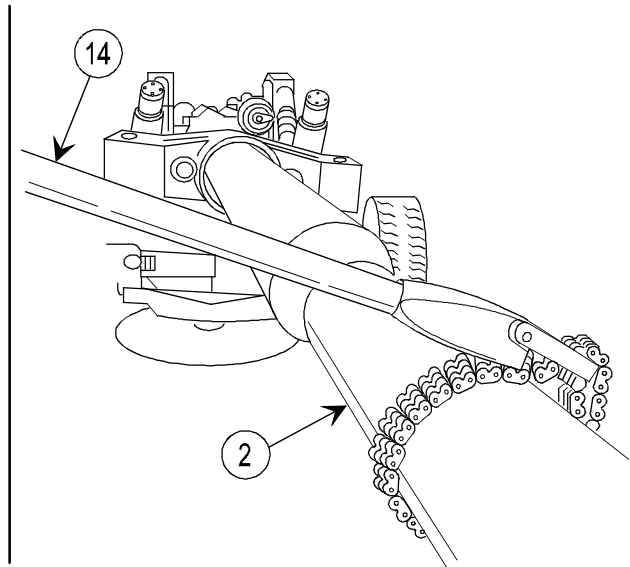
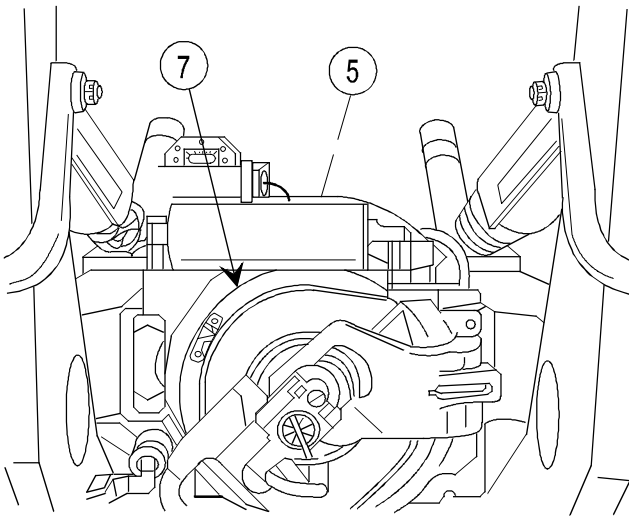

- 11 Turn cannon tube (2) with tube wrench (14) 1/8 turn counterclockwise, as seen from the muzzle end, to engage interrupted threads of breech mechanism assembly (7) with interrupted threads of recoil mechanism (5).

CAUTION

Breech mechanism assembly should be flush with rear yoke when torque key slot is alined.

- 12 Install torque key (15) and capscrew (16) in breech mechanism assembly (7) and install lock wire (item 39, appx B).

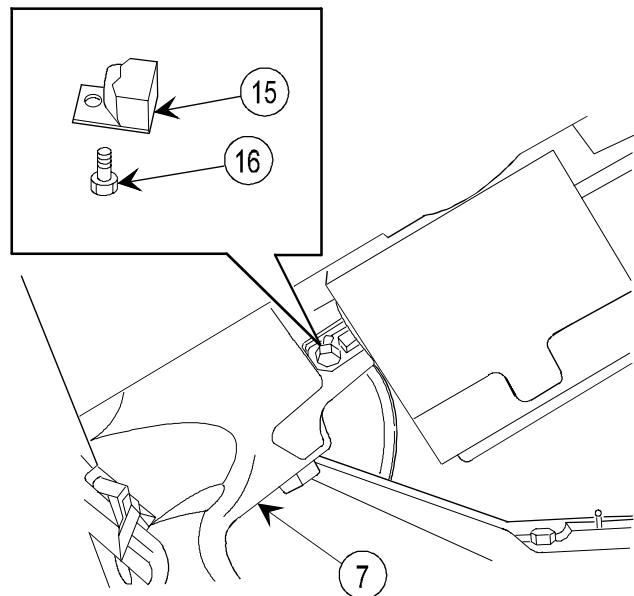

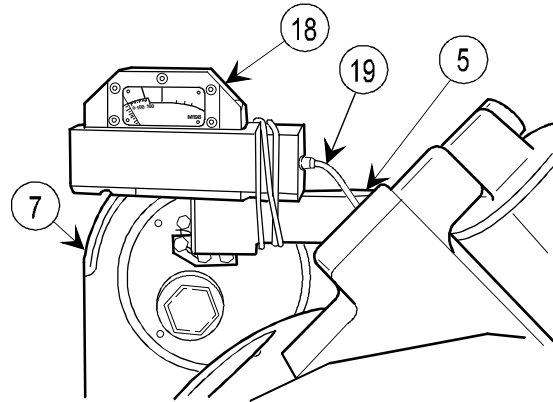
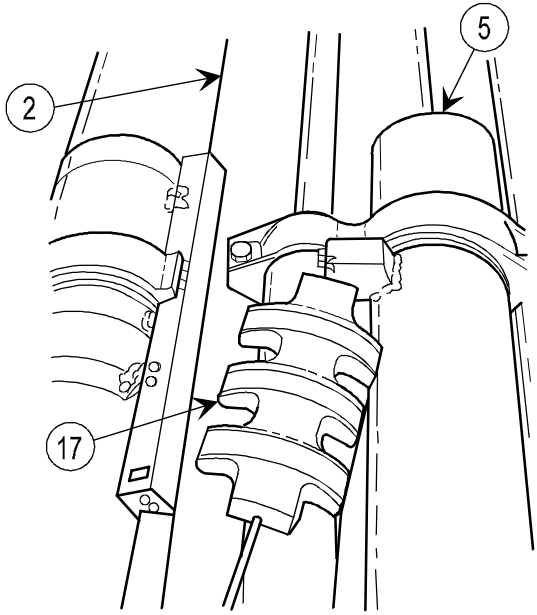

CAUTION

Lift housing assembly (17) and thermal warning device (18) at the same time when step 13 is performed. Moving either part by itself can damage the capillary tube (19).

- 13 Remove thermal warning device (18) from recoil mechanism (5), and position on breech mechanism assembly (7). Remove housing assembly (17) from recoil mechanism (5) and position on cannon tube (2) so lip on underside of housing sits in annular groove (20).
- 14 Install four screws (21) and torque to 47 ft-lb (63 N-m).
- 15 Install three hose clamps (22) over housing assembly (17), and torque to 5 ft-lb (7 N-m) plus starting torque of locknuts.
- 16 Install barrel clamp (23) and fourth hose clamp (22) over barrel clamp (23) with its front edge 6.00 ± 0.25 in. (15.24 ± 0.64 cm) from rear edge of housing assembly (17). Torque as in step 15.

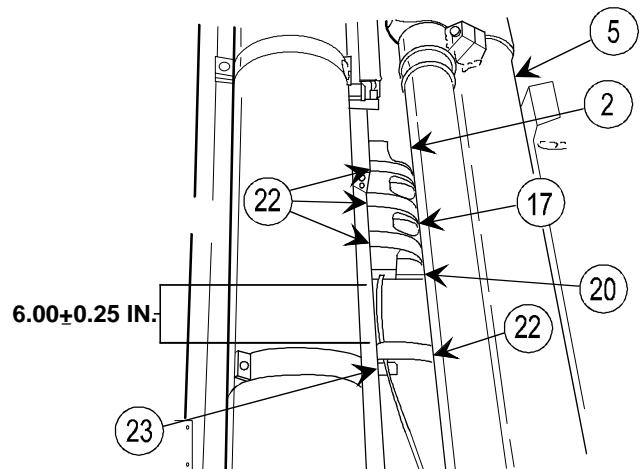
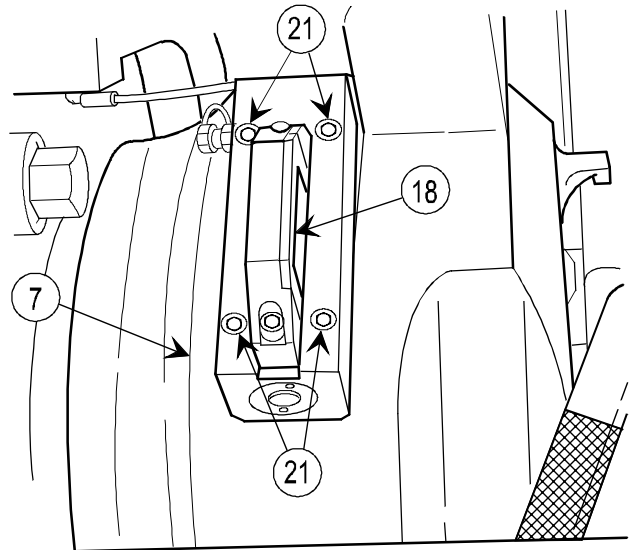

2-6. M199 CANNON—MAINTENANCE INSTRUCTIONS (cont)

INSTALLATION (cont)

17 Deleted.

NOTE

Fire control alignment tests and measurements (TM 9-1025-211-10) must be performed, appropriate adjustments made, and boresight and synchronization procedures (p 2-396) completed when M199 cannon or breech assembly is replaced.

18 To remove two safety strut assemblies (27):

- a. Remove safety pin (28) and pin (29) from each safety strut.
- b. Remove four nuts (30), four washers (31), four screws (32), and top cap (33) from each strut.
- c. Remove two safety strut assemblies (27), position top cap (33), and install screws (32), washers (31), and nuts (30).

19 Install recoil mechanism ballistic shield (34).

20 Install eight lockwashers (35), eight capscrews (36), and lock wire (item 34, appx B).

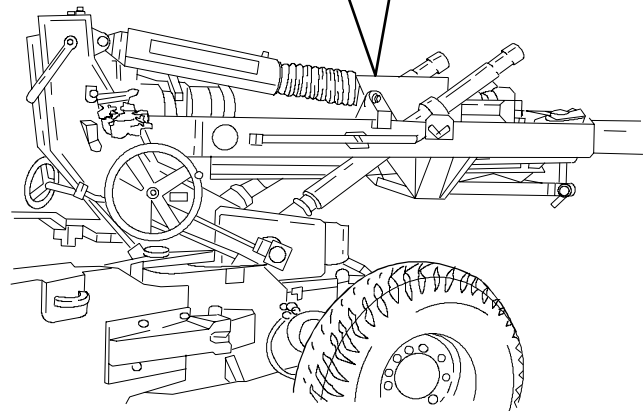
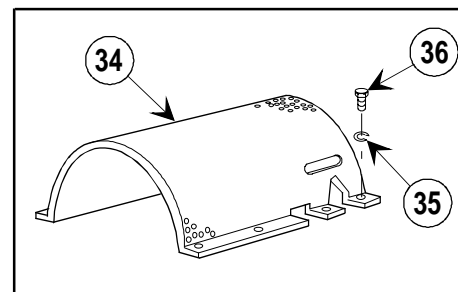
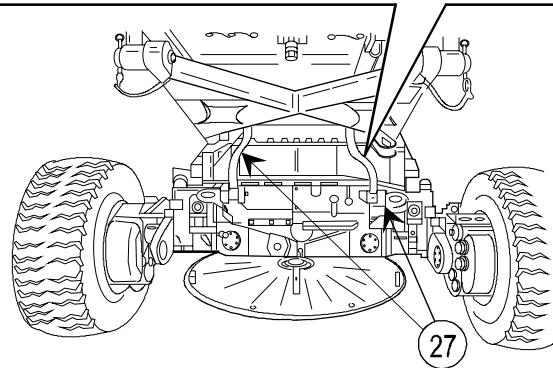
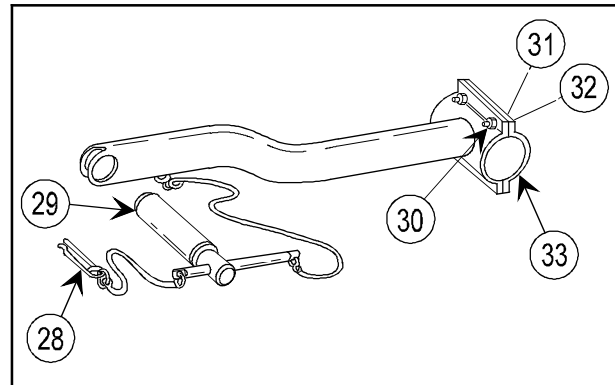

2-7. THERMAL WARNING DEVICE—MAINTENANCE INSTRUCTIONS

THIS TASK COVERS:

- | | | |
|---------------|-----------------|----------------------|
| a. Removal | b. Disassembly | c. Inspection/repair |
| d. Reassembly | e. Installation | f. Calibration |

INITIAL SETUP

Tools and Special Tools

Artillery field maintenance shop equipment (SC 4933-95-CL-A12)

M198 repairman field artillery tool kit (5911278)

Materials/Parts

Gasket (11578942)

Gasket (11578945)

Gasket (11578952)

Preformed packing (MS29513-008)

Preformed packing (MS29315-029)

Sealing compound (item 25, appx B)

Self-locking nut (MS21083C3)

References

TM 9-1025-211-10

TM 9-1025-211-20&P

TM 9-1025-211-34P

Equipment Conditions

Cannon tube elevated or depressed to zero elevation (TM 9-1025-211-10)

2-23 Recoil mechanism ballistic shield removed

2-23 Housing assembly and thermal warning device detached from cannon tube but not removed

REMOVAL

NOTE

Lift housing assembly and thermal warning device together to position housing assembly for sensing bulb removal.

- 1 Position housing assembly (1) for sensing bulb (2) removal.
- 2 Remove setscrew (3), and lightly tap forward end of housing assembly (1) with soft face hammer, holding onto capillary tube (4).
- 3 Remove sensing bulb (2) from housing assembly (1).

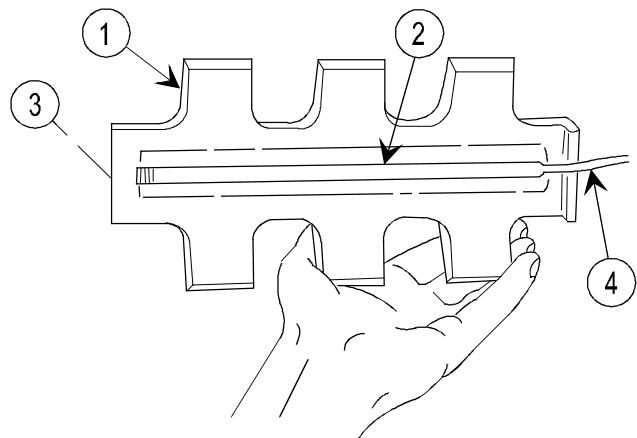

2-7. THERMAL WARNING DEVICE—MAINTENANCE INSTRUCTIONS (cont)

REMOVAL (cont)

- 4 Remove thermal warning device (5) and capillary tube (4) from breech mechanism assembly.

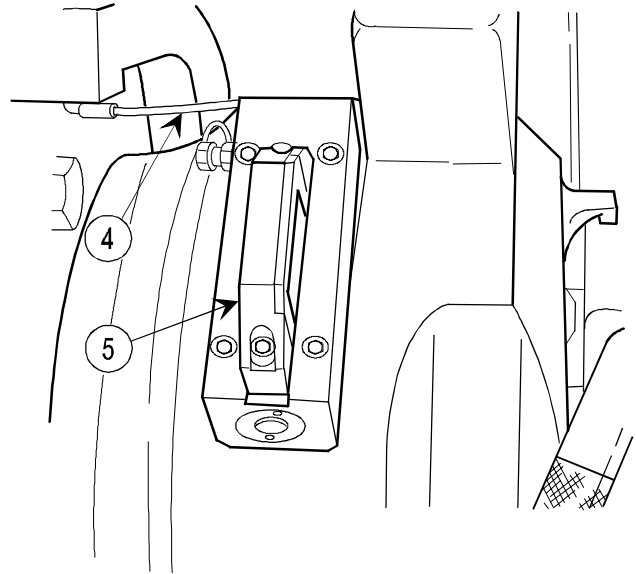

DISASSEMBLY

- 1 Remove four capscrews (1).
- 2 Remove cover (2) and gasket (3). Discard gasket (3).
- 3 Remove two capscrews (4).
- 4 Remove upper housing (5) from lower housing (6).

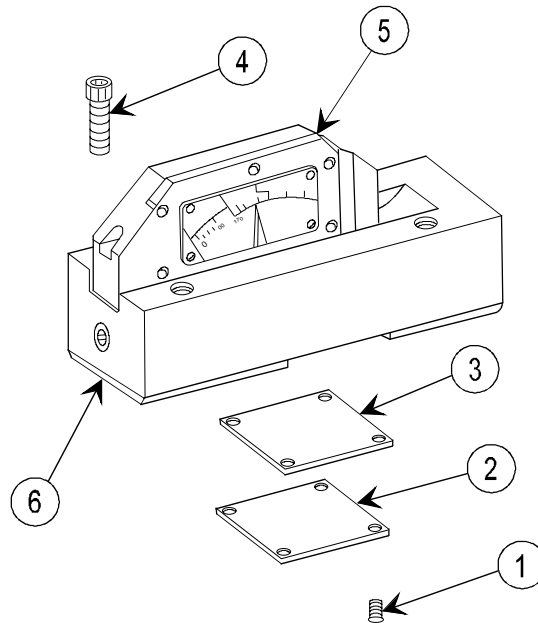

- 5 Remove setscrew (7), pivot (8), and preformed packing (9).
- 6 Remove dial pointer (10).

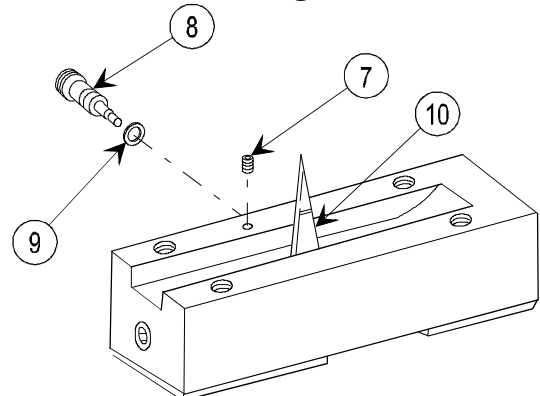

CAUTION

To prevent mercury loss from thermal sensing element, keep bulb below piston end.

NOTE

Parts in steps 7 thru 12 are shown removed from lower housing for clarity.

- 7 Unscrew and remove thermal sensing element (11). Keep bulb (12) below piston end (13).
- 8 Remove preformed packing (14).
- 9 Loosen nut (15) on shaft (16).
- 10 Remove plunger (17) from shaft (16).
- 11 Remove spring (18).
- 12 Remove pin (19).

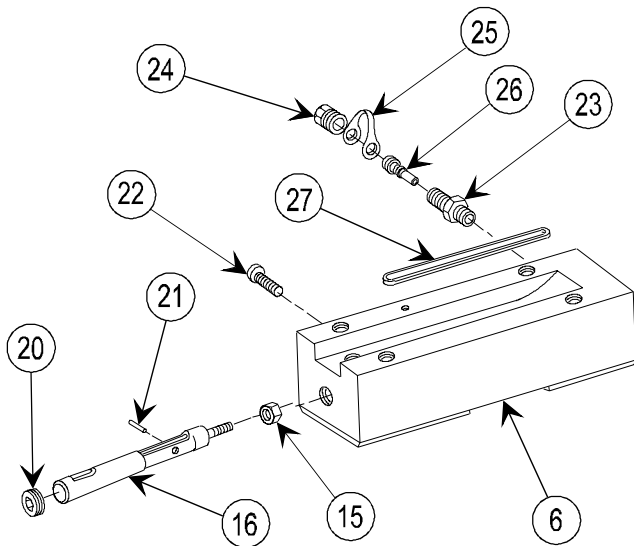
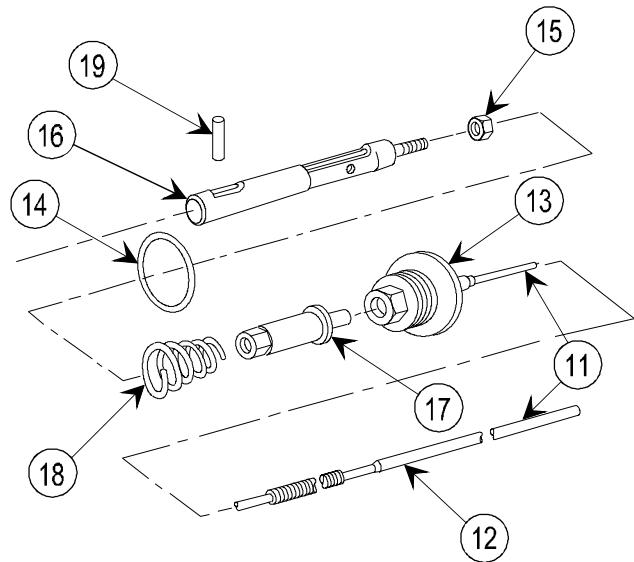

- 13 Remove pipe plug (20).
- 14 Remove shaft (16) from lower housing (6).
- 15 Remove pin (21) and nut (15). Discard nut (15).
- 16 Remove screw (22) from lower housing (6).
- 17 Remove valve stem (23) from lower housing (6).
- 18 Remove valve cap (24), strap (25), and valve core (26).

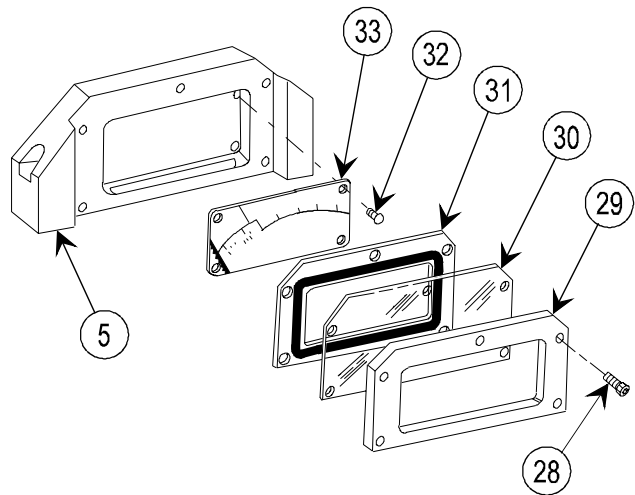

- 19 Remove and discard gasket (27).
- 20 Remove five capscrews (28).
- 21 Remove window retainer (29), dial window (30), gasket (31), four screws (32), and scale plate (33) from upper housing (5). Discard gasket (31).

2-7. THERMAL WARNING DEVICE—MAINTENANCE INSTRUCTIONS (cont)

INSPECTION/REPAIR

- 1 Check for broken, damaged, or missing parts.
- 2 Repair is by replacement of authorized parts (TM 9-1025-211-34P).
- 3 If lower housing assembly is damaged, replace entire thermal warning device.

REASSEMBLY

- 1 Install scale plate (1), four screws (2), new gasket (3), dial window (4), and window retainer (5) in upper housing (6).

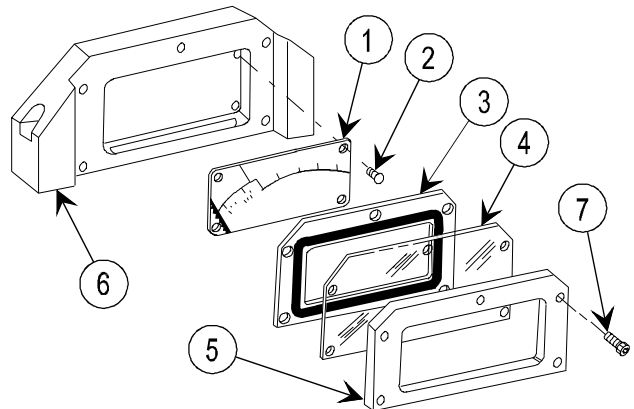

- 2 Install five capscrews (7).
- 3 Install new gasket (8).
- 4 Assemble valve core (9), strap (10), valve cap (11), and valve stem (12).
- 5 Install valve stem (12).
- 6 Install screw (13) in lower housing (14).
- 7 Assemble new self-locking nut (15) and plain pin (16) to shaft 17).
- 8 Install shaft (17) in lower housing (14).
- 9 Coat threads of pipe plug (18) with sealing compound and install.
- 10 Install spring (19).
- 11 Install pin (20).
- 12 Install plunger (21) on shaft (17).
- 13 Tighten nut (15) against plunger (21).
- 14 Install new preformed packing (22).

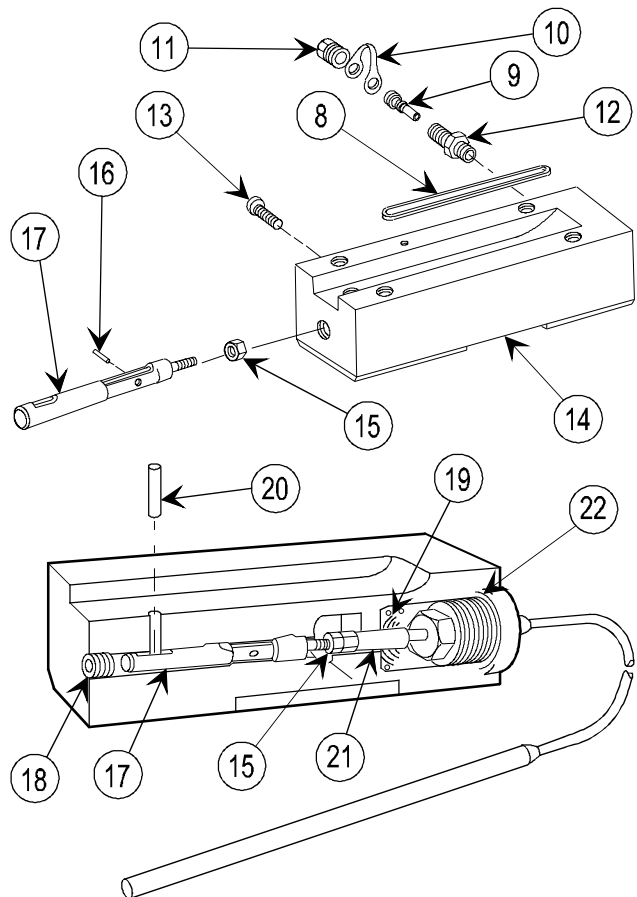

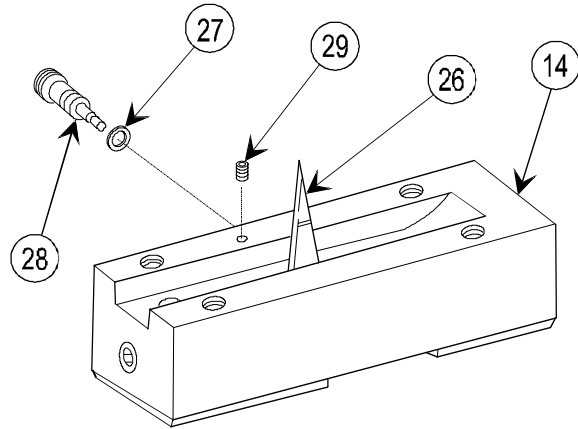
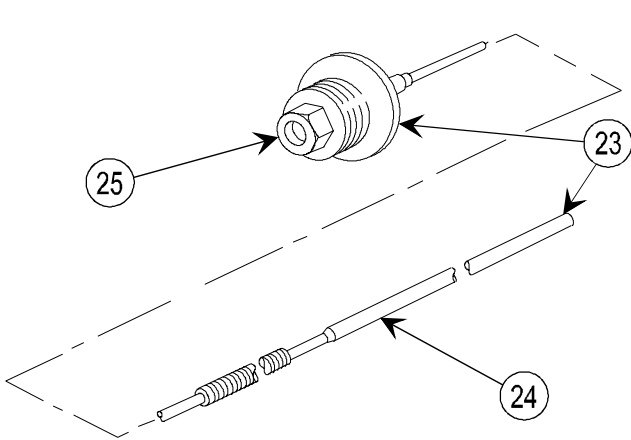

CAUTION

To prevent mercury loss, keep bulb below piston end.

- 15 Install thermal sensing element (23). Keep bulb (24) below piston end (25). Perform calibration (p 2-40) if new thermal sensing element is installed.
- 16 Install dial pointer (26).
- 17 Install new preformed packing (27), pivot (28), and setscrew (29) in lower housing (14).
- 18 Install upper housing (6) on lower housing (14).
- 19 Install two capscrews (30) and apply sealing compound to cavity of head.

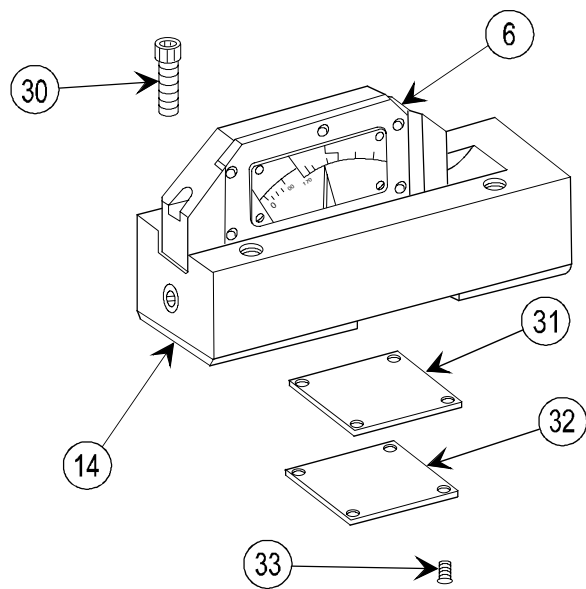

NOTE

Check calibration (p 2-40) prior to completing reassembly.

- 20 Install new gasket (31) and cover (32).
- 21 Install four capscrews (33) and apply sealing compound to cavity of head.

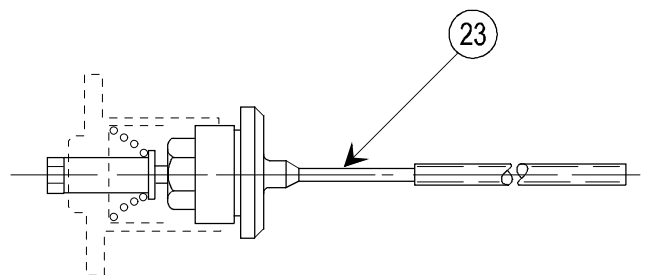

NOTE

Purge thermal warning device housing (TM 9-1025-211-20&P).

A new thermal sensing element (23) is shipped with an element housing. Save the element housing, and install it on thermal sensing element for shipping purposes.

2-7. THERMAL WARNING DEVICE—MAINTENANCE INSTRUCTIONS (cont)

INSTALLATION

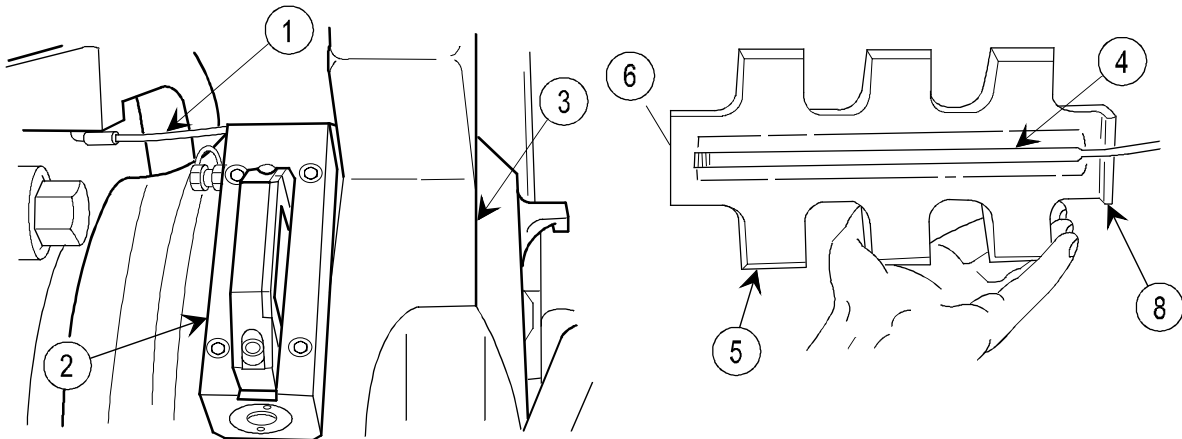

- 1 Carefully position capillary tube (1) and thermal warning device (2) on breech mechanism assembly (3).
- 2 Carefully place sensing bulb (4) in position in housing assembly (5).

CAUTION

Tighten setscrew (6) just enough to seat sensing bulb (4). Excess tightening will damage sensing bulb (4).

- 3 Tighten setscrew (6), forcing sensing bulb (4) further into its seat.
- 4 Position housing assembly (5) on cannon tube (7) and at same time position thermal warning device on breech so lip (8) on underside of housing sits in annular groove (9) on cannon tube.

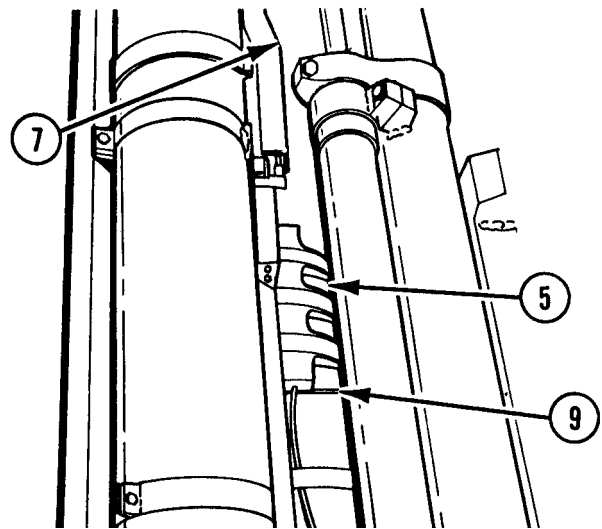

CALIBRATION

NOTE

Thermal warning device must be removed (p 2-23) for calibration.

- 1 Loosen setscrew (1).
- 2 Turn pivot (2) clockwise as far as possible.
- 3 Remove four capscrews (3), cover (4), and gasket (5). Discard gaskets (5).

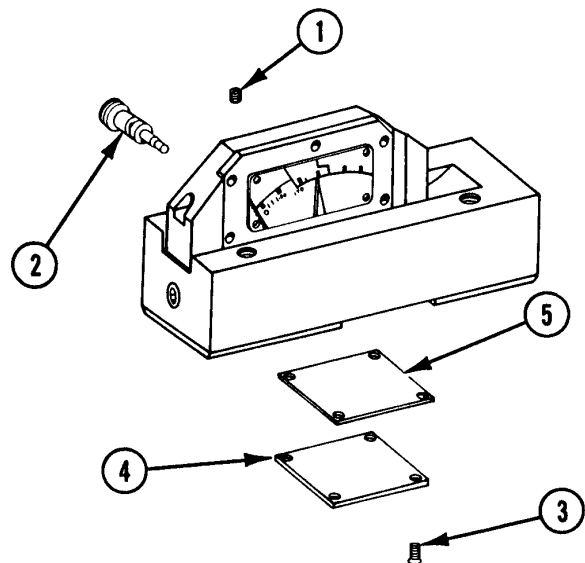

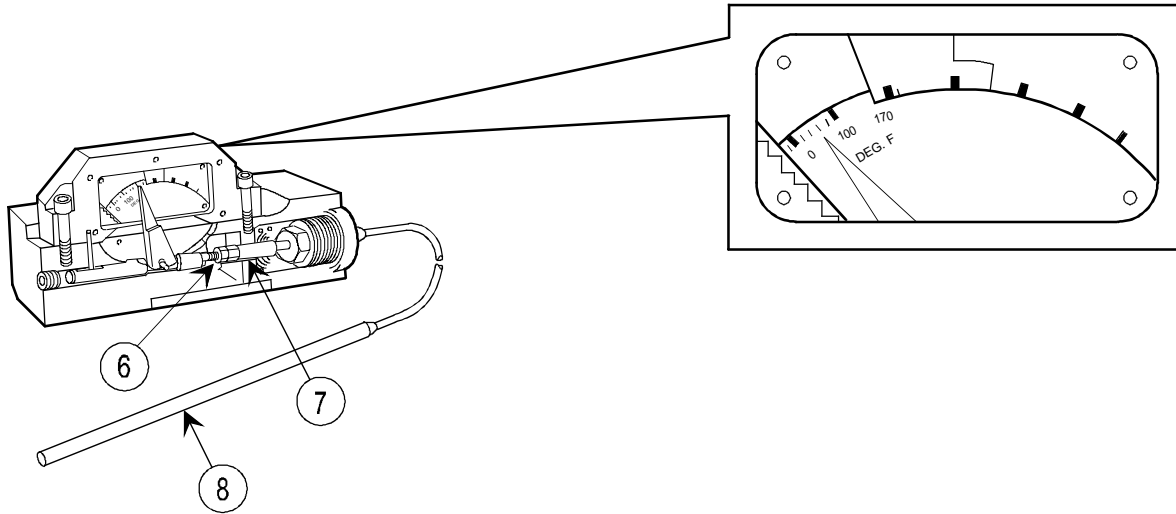

- 4 Loosen nut (6) while holding plunger (7).
- 5 Turn plunger (7) until ambient temperature is indicated.
- 6 Tighten nut (6).
- 7 Place thermal sensing bulb (8) in boiling water until a stable reading is reached.

NOTE

Do not turn pivot (2) more than one complete revolution.

- 8 Turn pivot (2) counterclockwise to align dial pointer (9) with calibration mark (10).
- 9 Tighten setscrew (11).
- 10 Remove thermal sensing bulb (8) from boiling water and allow to cool to ambient temperature. If ambient temperature does not register, repeat steps 4 thru 9.
- 11 Install new gasket (5), cover (4), and four capscrews (3).
- 12 Fill in pivot (2) and setscrew (1) cavities with sealing compound flush with surface.
- 13 Install thermal warning device (p 2-23), and purge (TM 9-1025-211-20&P).

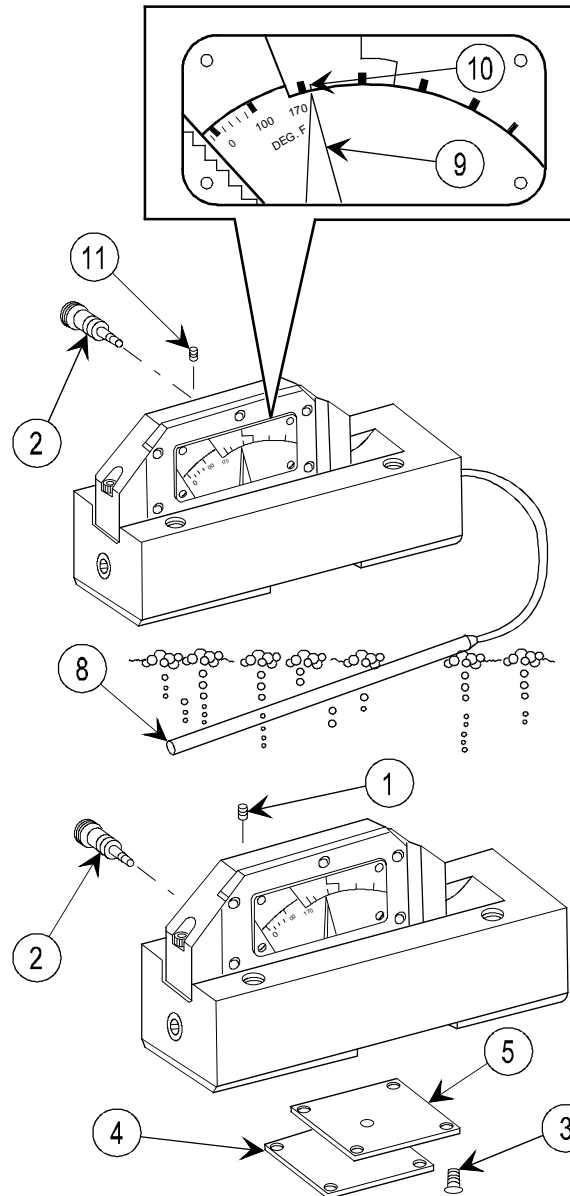

2-8. CANNON TUBE—MAINTENANCE INSTRUCTIONS

THIS TASK COVERS:

- a. Inspection b. Removal c. Inspection/repair d. Installation

INITIAL SETUP

Tools and Special Tools

- Artillery field maintenance shop equipment (SC 4933-95-CL-A12)
- Gun tube sling (8735439/8735440)
- M198 repairman field artillery tool kit (5911278)
- M3 borescope (11584701)
- Pullover gage (7242997)
- 3-ton hoist available

Materials/Parts

- Cleaning compound (item 7, appx B)
- Lock wire (item 39, appx B)
- WTR grease (item 11, appx B)

Personnel Required: 2

- Artillery repairmen

References

- Deleted
- TM 9-1000-202-14
- TM 9-1025-211-10
- TM 9-1025-211-20&P
- TM 9-1025-211-34P
- TM 9-4933-258-13&P
- TM 9-6650-235-13&P

Equipment Conditions

- Trails spread and locked into position (TM 9-1025-211-10)
- Howitzer lowered onto firing assembly baseplate (TM 9-1025-211-10)
- Cannon tube elevated or depressed to zero elevation (TM 9-1025-211-10)
- Handbrakes applied and wheels locked (TM 9-1025-211-10)
- Muzzle brake removed (TM 9-1025-211-20&P)
- 2-23 Safety strut assemblies installed
- 2-23 Recoil mechanism ballistic shield removed
- 2-23 Thermal warning device removed

General Safety Instructions

WARNING

Be sure weapon is secured with safety strut assemblies. Failure to install safety strut assemblies may result in serious injury to personnel and damage to equipment.

All lifting devices must be checked in accordance with local Standing Operating Procedure (SOP) to make sure they are in good working condition before starting the lifting operation.

INSPECTION

Use M3 borescope and pullover gage to check for damaged grooves in cannon tube. (Refer to TM 9-1000-202-14, TM 9-4933-258-13&P, and TM 9-6650-235-13&P.)

REMOVAL

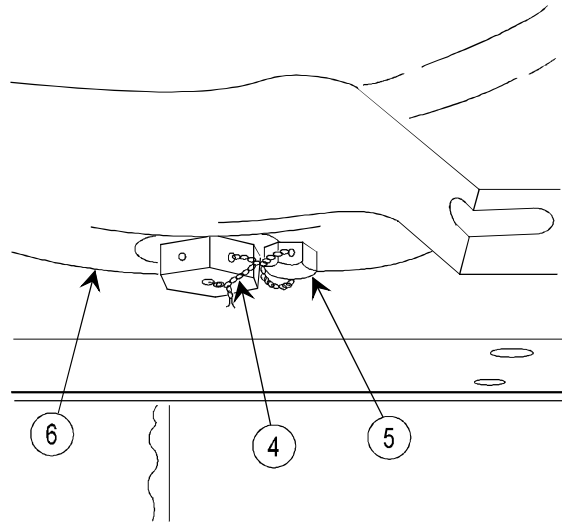

- 1 Deleted.
- 2 Remove lock wire (4) and capscrew (5) from breech mechanism assembly (6).

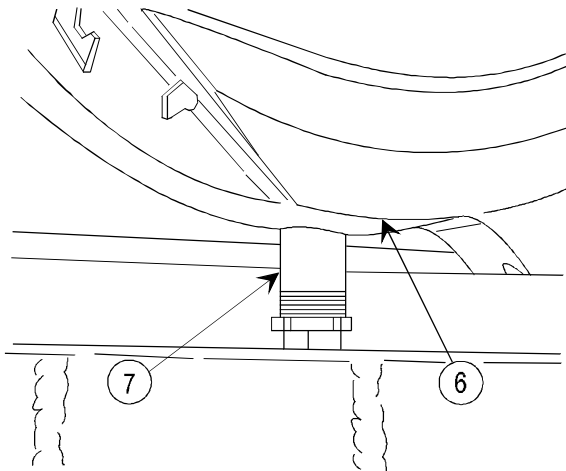

NOTE

Tube lock key (7) cannot be completely removed, but will not interfere with tube removal.

- 3 Unscrew tube lock key (7) from breech mechanism assembly (6).

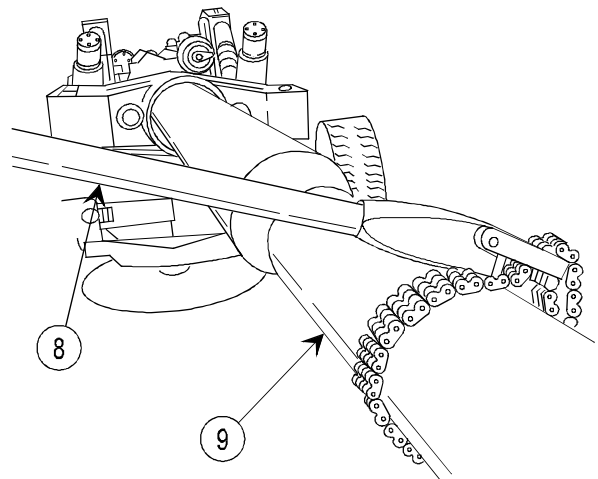

- 4 Using tube wrench (8), turn cannon tube (9) 1/8 turn counterclockwise as viewed from muzzle end.

2-8. CANNON TUBE—MAINTENANCE INSTRUCTIONS (cont)

REMOVAL (cont)

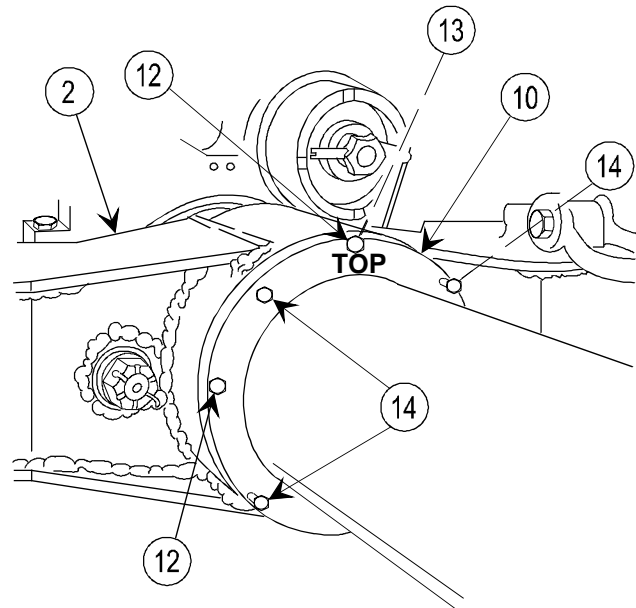
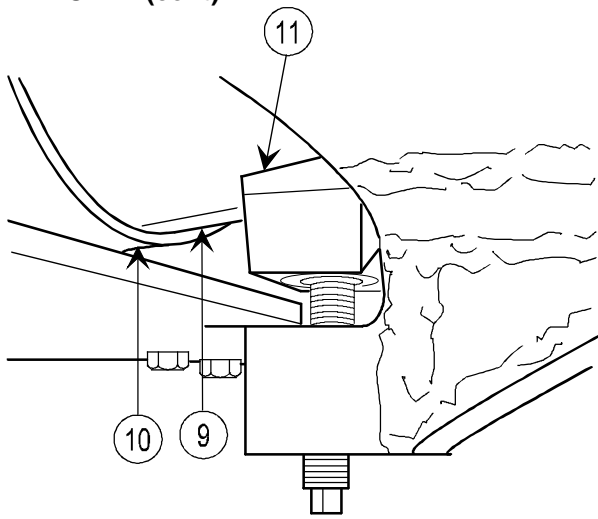

- 5 Raise cannon tube (9) to center in bearing unit housing (10) with rest assembly (11).
- 6 Remove four screws (12) and four washers (13) from bearing unit housing (10).
- 7 Install four screws (12) in jack screw holes (14) in bearing unit housing (10).

NOTE

When tightening screws (12) in jack screw holes (14), it may be necessary to tap on screws (12) and bearing unit housing (10) during removal. If screws (12) become hard to turn, try raising or lowering the cannon tube (9) with rest assembly (11) to minimize friction.

- a. Alternately tighten four screws (12) until bearing unit housing (10) comes out of cradle assembly (2).
- b. Remove four screws (12) from bearing unit housing (10).

- 8 Slide bearing unit housing (10) off of cannon tube (9).

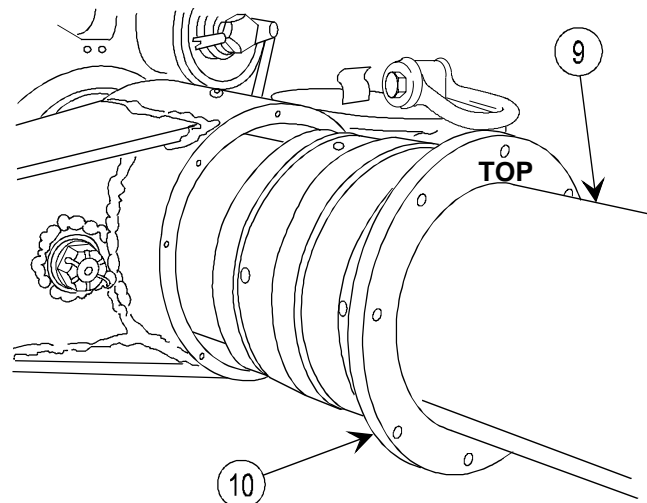

- 9 Install gun tube sling (15) on cannon tube (9) directly in front of cradle assembly (16) and attach to 3-ton hoist (17).

WARNING

Cannon tube (9) weighs approximately 4000 lb (1814 kg).

NOTE

Insert a timber in muzzle end of cannon tube to assist in cannon tube removal from recoil mechanism.

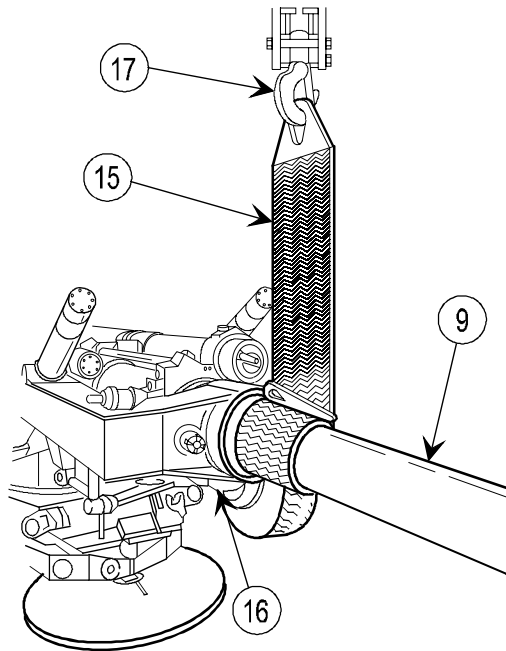

- 10 Raise cannon tube to take weight off of rest assembly (11).

- 11 Screw down rest assembly (11).

CAUTION

Use care when sliding cannon tube (9) through recoil yokes.

- 12 Slide cannon tube (9) forward until chamfer is exposed from cradle assembly.

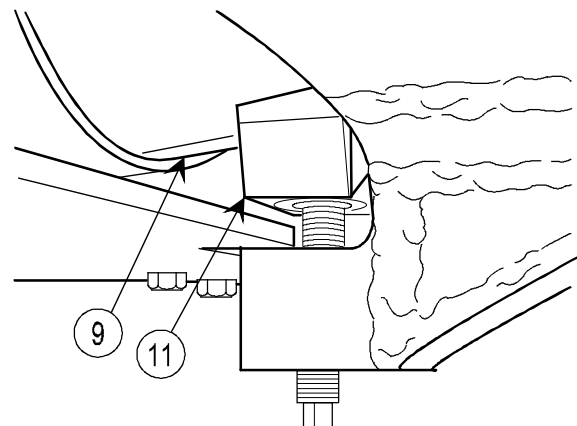

NOTE

Center of balance of cannon tube (9) with muzzle brake removed is 141.5 in. (359.4 cm) from muzzle end of cannon tube (9).

A 2 x 4 will help to eliminate space between sling (15) and small diameter of cannon tube.

- 13 Release pressure, and slide gun tube sling (15) to center of balance on cannon tube (9).

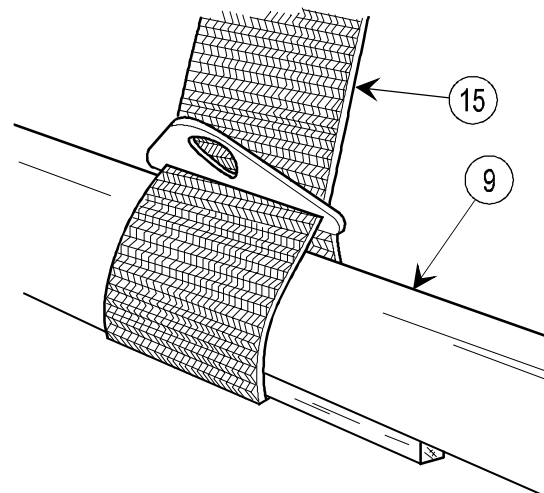

2-8. CANNON TUBE—MAINTENANCE INSTRUCTIONS (cont)

REMOVAL (cont)

- 14 Lift and remove cannon tube (9) from cradle assembly (16).
- 15 Lower cannon tube (9) to suitable supports (18), and unhook gun tube sling (15) from 3-ton hoist (17).

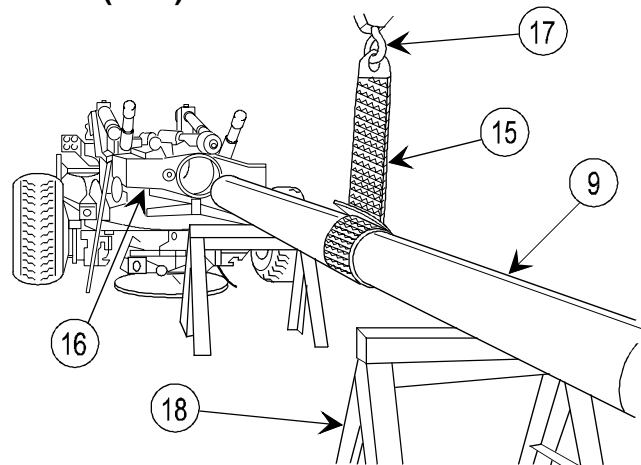

INSPECTION/REPAIR

- 1 Clean bearing unit housing and cannon tube and breech mechanism threads with cleaning compound.
- 2 Check bearing unit housing, cannon tube, and breech mechanism for damage.
- 3 Repair is by replacement of authorized parts (TM 9-1025-211-34P).
- 4 Lubricate bearing unit housing and cannon and breech mechanism threads with WTR grease.

INSTALLATION

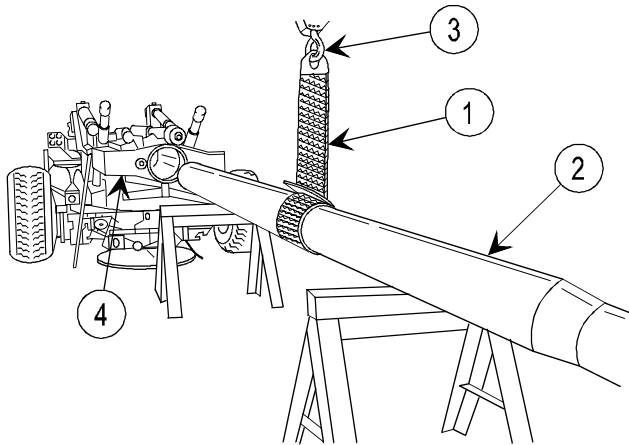

- 1 Place gun tube sling (1) on cannon tube (2) at center of balance and attach to 3-ton hoist (3).

NOTE

Aline threads of cannon tube (2) with threads of breech mechanism assembly for proper installation.

Insert timber in muzzle end of cannon tube to assist in cannon tube installation.

- 2 Lift and place cannon tube (2) in cradle assembly (4).

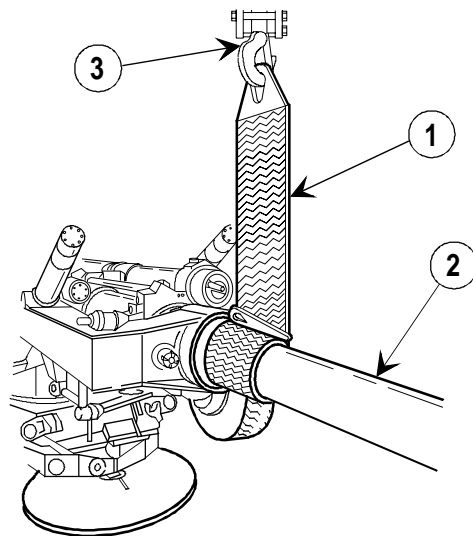

- 3 Using 3-ton hoist (3), release pressure on gun tube sling (1).
- 4 Reposition gun tube sling (1) forward on cannon tube (2).

CAUTION

Insert gun tube into breech mechanism assembly slowly until it stops to keep from damaging threads on either or cannon breech mechanism.

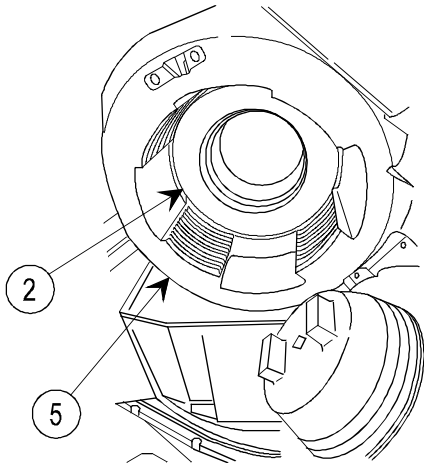

- 5** Slide cannon tube (2) forward into breech mechanism assembly (5).

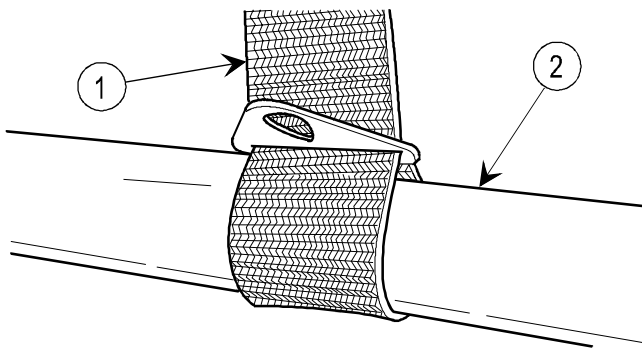

- 7** Lower hoist and remove sling (1) from hoist and cannon tube (2).

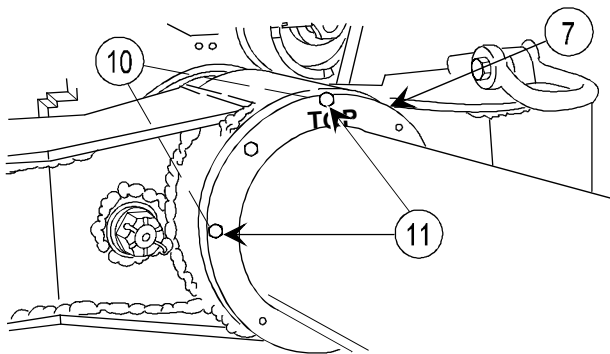

- 9** Install four washers (10) and four screws (11). Torque screws (11) to 9 ft-lb (12 N-m).
- 10** Lubricate bearing unit housing (7) according to TM 9-1025-211-10, appx F.

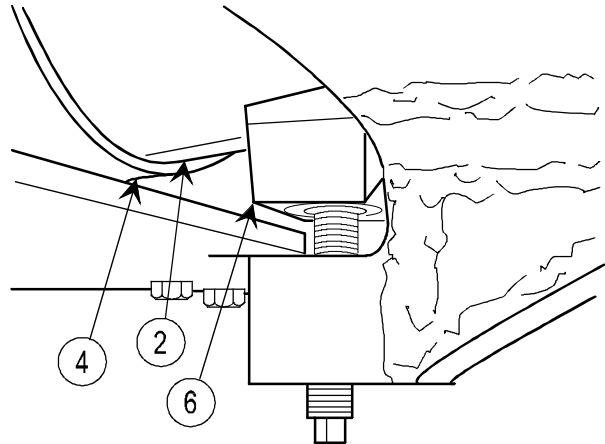

- 6** Raise rest assembly (6) to support weight of cannon tube (2) in approximately center of cradle assembly (4) opening.

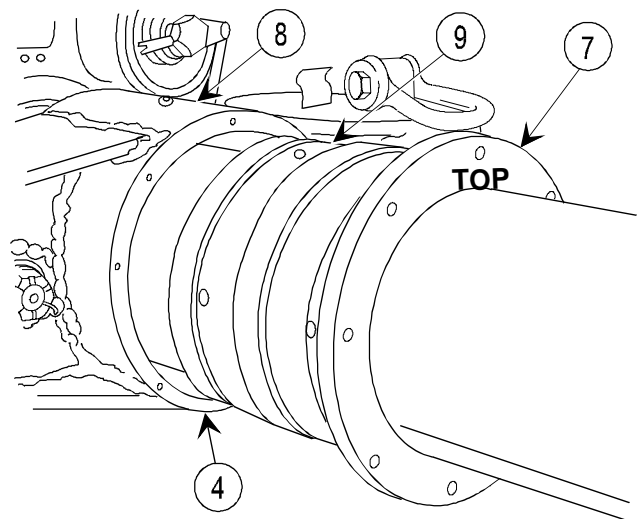

- 8** Install bearing unit housing (7) in cradle assembly (4), aligning the two fittings (8) in cradle assembly with holes (9) and TOP facing up.

- 11** Deleted.

2-8. CANNON TUBE—MAINTENANCE INSTRUCTIONS (cont)

INSTALLATION (cont)

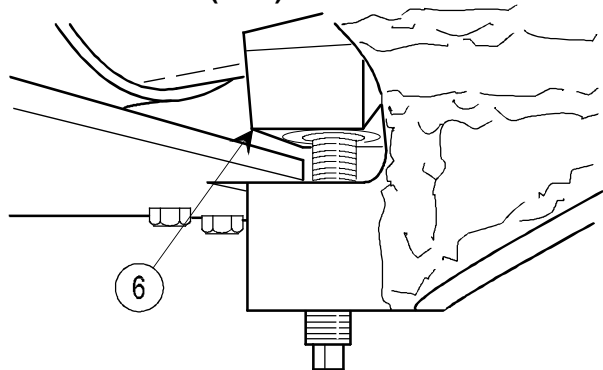

12 Lower rest assembly (6).

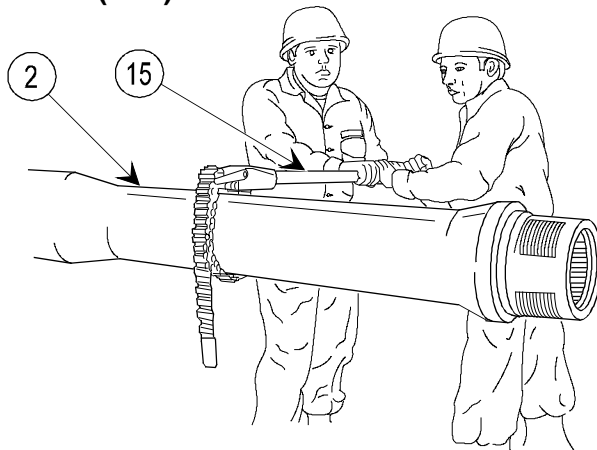

13 Using tube wrench (15), turn cannon tube (2) 1/8 turn clockwise (as viewed from muzzle end) to engage interrupted threads on end of cannon tube with threads in breech ring assembly.

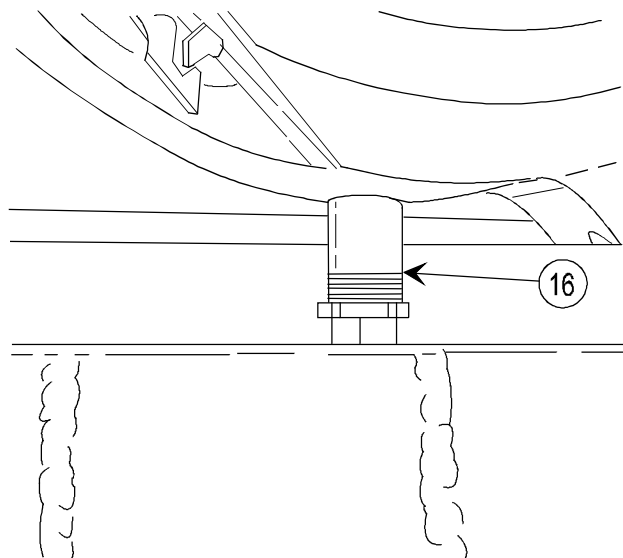

14 Install tube lock key (16).

16 Stamp retube number below the word RETUBED on breech ring assembly.

NOTE

Fire control alignment tests and measurements (TM 9-1025-211-10) must be performed and adjustments made and the boresight and synchronization procedure (2-396) must be completed when the cannon tube has been replaced.

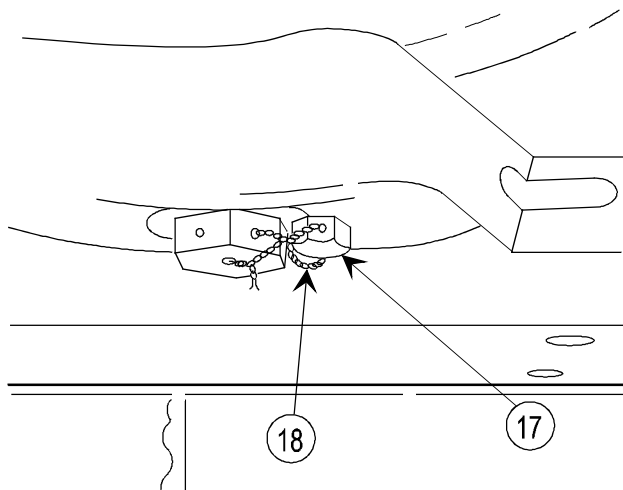

15 Install cap screw (17) and lock wire (18).

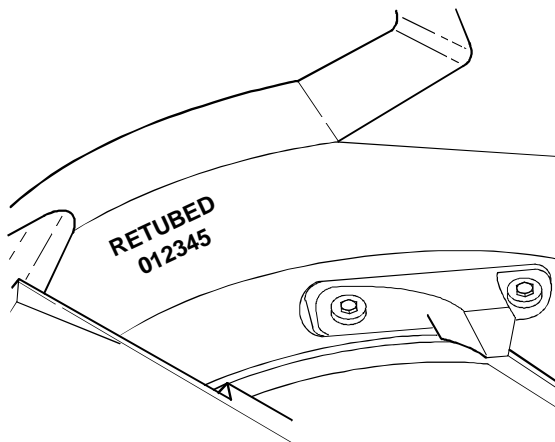

2-9. BREECH MECHANISM ASSEMBLY—MAINTENANCE INSTRUCTIONS

THIS TASK COVERS:

- | | | |
|---------------|-----------------|----------------------|
| a. Removal | b. Disassembly | c. Inspection/repair |
| d. Reassembly | e. Installation | |

INITIAL SETUP

Tools and Special Tools

- Artillery and turret mechanic's ordnance tool kit (SC 5180-95-CL-A12)
- Artillery field maintenance shop equipment (SC 4933-95-CL-A12)
- M198 repairman field artillery tool kit (5911278)
- Lifting device available

Materials/Parts

- Grooved headless pin (11579233)
- Lock wire (item 39, appx B)

References

- TM 9-1025-211-10
- TM 9-1025-211-20&P
- TM 9-1025-211-34P

Personnel Required: 2

- Artillery repairmen

Equipment Conditions

- Breech mechanism assembly closed (TM 9-1025-211-10)
- Cannon tube depressed to zero elevation (TM 9-1025-211-10)
- 2-23 Thermal warning device disconnected and attached to recoil mechanism
- 2-23 Safety strut assemblies installed

General Safety Instructions

WARNING

All lifting devices must be checked in accordance with local Standing Operating Procedure (SOP) to make sure they are in good working condition before starting the lifting operation.

REMOVAL

- 1 Remove lock wire, capscrew (1), and torque key (2) from breech mechanism assembly (3).

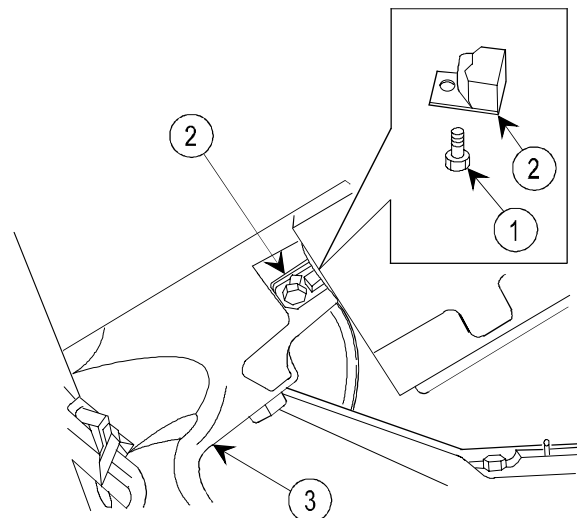

2-9. BREECH MECHANISM ASSEMBLY—MAINTENANCE INSTRUCTIONS (cont)

REMOVAL (cont)

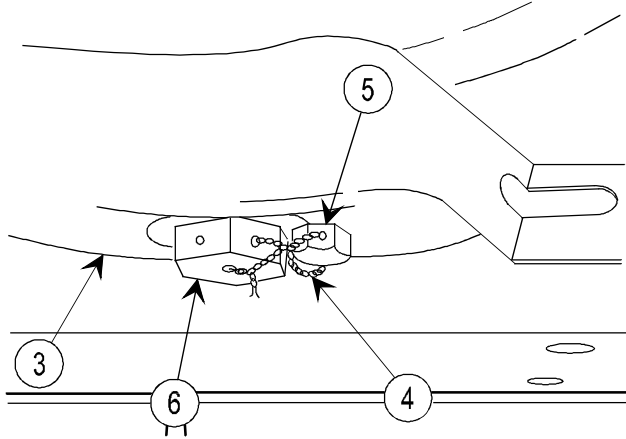

- 2 Remove lock wire (4), capscrew (5), and tube lock key (6) from breech mechanism assembly (3). Let tube lock key (6) rest on top carriage assembly. It may be removed when breech is unlocked.

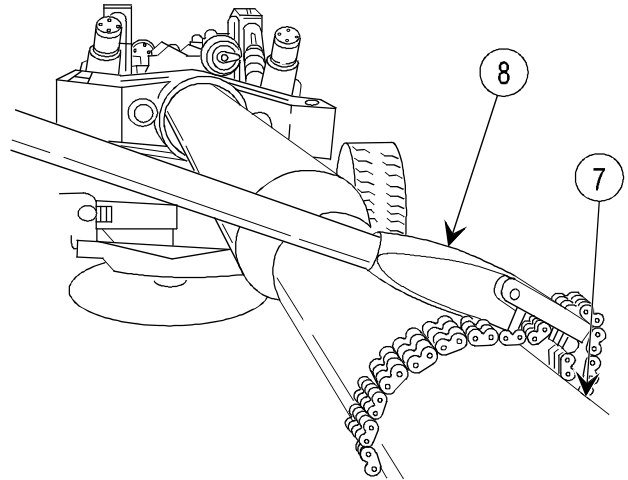

- 3 Hold cannon tube (7) in place with tube wrench (8).

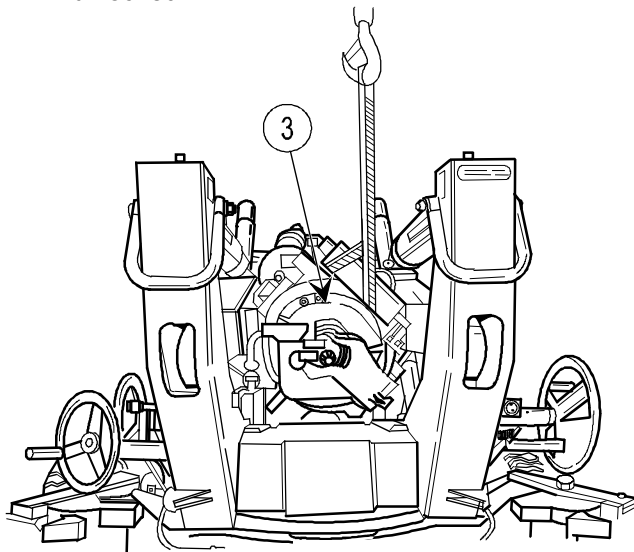

WARNING

Breech mechanism assembly weighs 930 lb (422 kg). Use care when removing and installing.

- 4 Attach suitable sling to breech mechanism assembly (3) and facing breech end, rotate 1/8 turn counterclockwise, and lift off.

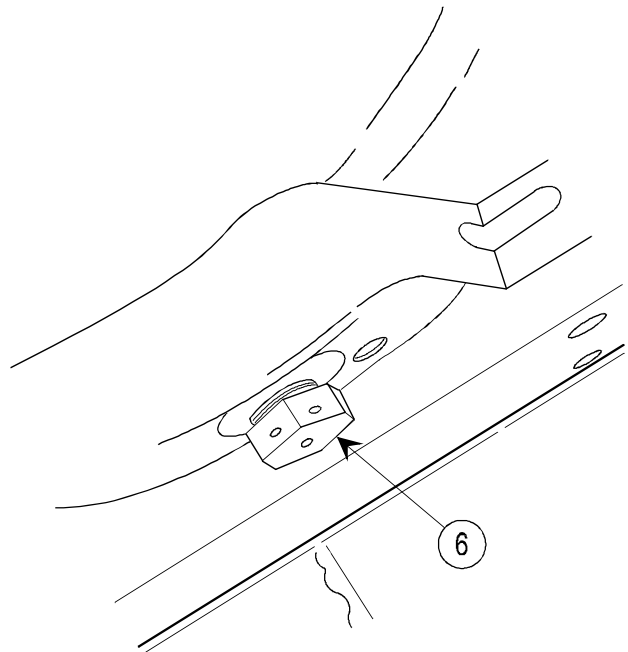

NOTE

Counterbalance should be parallel to the ground when breech is unlocked.

- 5 Remove tube lock key (6).

DISASSEMBLY

NOTE

Steps 1 thru 20 can be accomplished with breech mechanism assembly on howitzer.

- 1 Place firing mechanism block assembly (1) in left position.
- 2 Press firing mechanism assembly (2) in, turn approximately 1/4 turn clockwise, and remove.
- 3 Unlock breechblock assembly (3) using breechblock lever (4). Rotate breechblock assembly (3) with handle (5) until slot (6) is in the horizontal position.

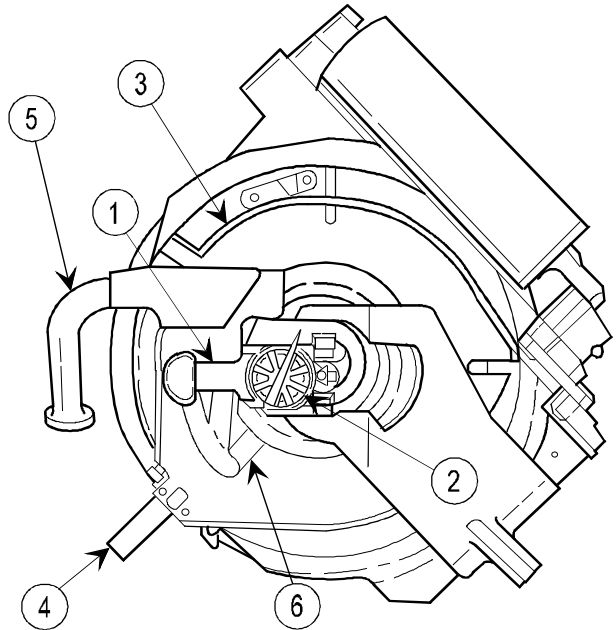

- 4 Pull out on spring pin (7), slide firing mechanism block assembly (1) to the right, and remove.

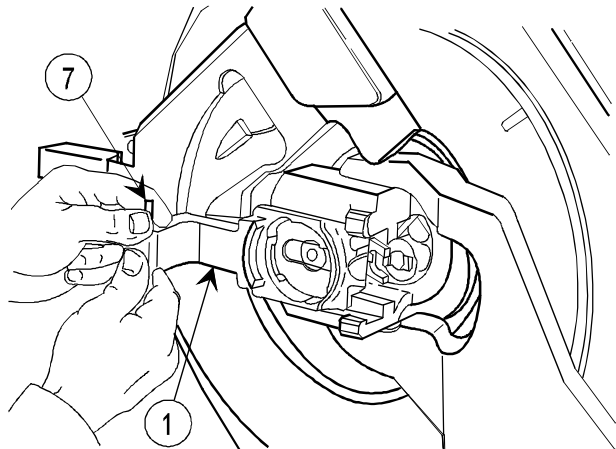

- 5 Open breechblock assembly (3) using handle (5).

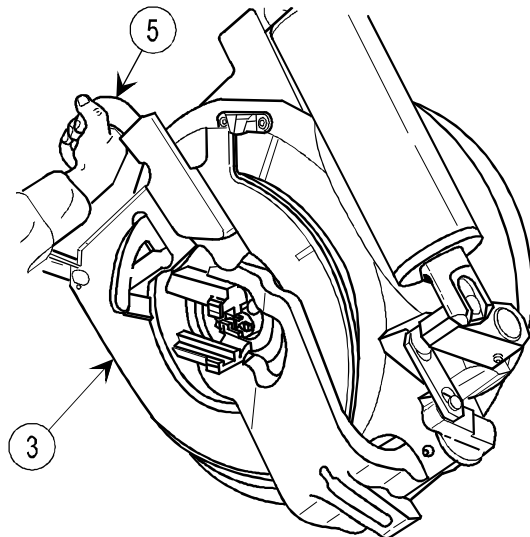

2-9. BREECH MECHANISM ASSEMBLY—MAINTENANCE INSTRUCTIONS (cont)

DISASSEMBLY (cont)

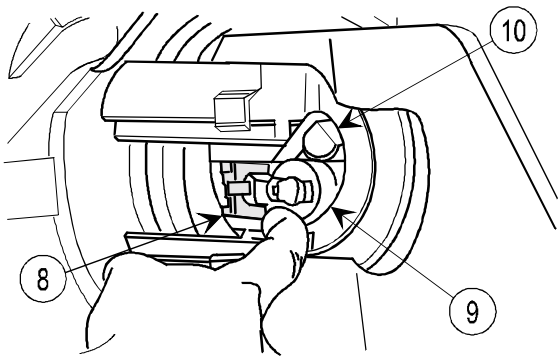

- 6 Lift cartridge extractor (8) away from obturator spindle assembly (9).
- 7 Depress plunger (10), located in end of obturator spindle assembly (9).

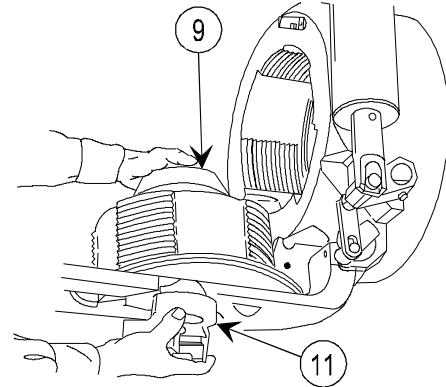

- 8 While supporting the housing assembly (11), turn obturator spindle assembly (9) clockwise until housing assembly is released.
- 9 Remove housing assembly (11).

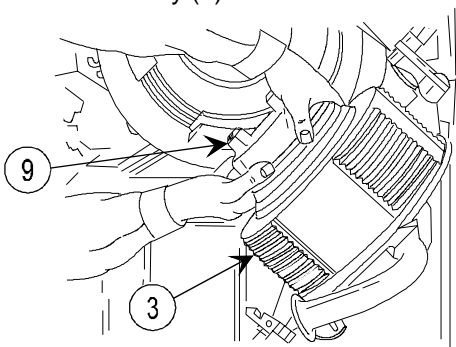

- 10 Lift obturator spindle assembly (9) and parts from breechblock assembly (3).

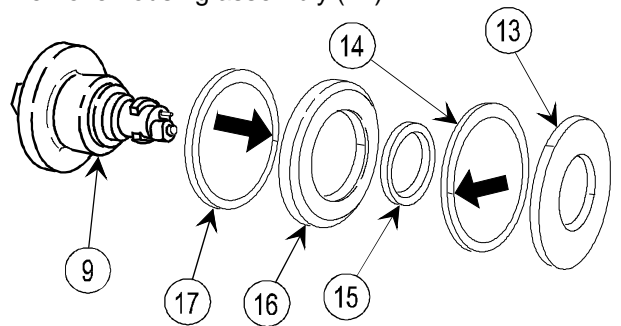

- 11 Remove disk (13), rear split ring (14), inner ring (15), obturator pad (16), and front split ring (17) from obturator spindle assembly (9).

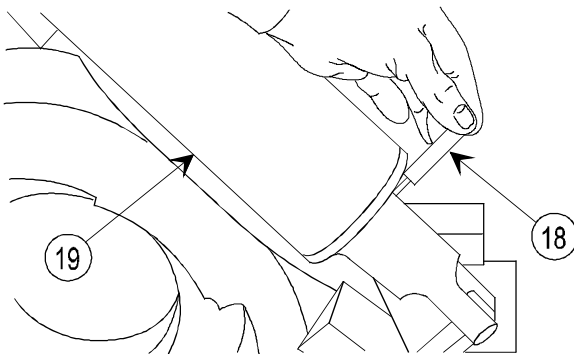

- 12 Install pin (18) in hole in breech counterbalance (19).

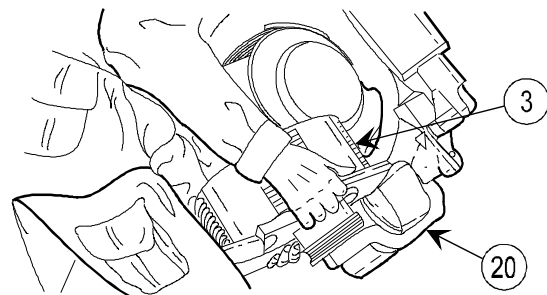

- 13 Lift breechblock assembly (3) from carrier (20).

WARNING

Personal injury may occur when removing breechblock if safety pin (18) is not installed in counterbalance shaft.

WARNING

Breechblock assembly (3) weighs 128 lb (58 kg). Use care when removing.

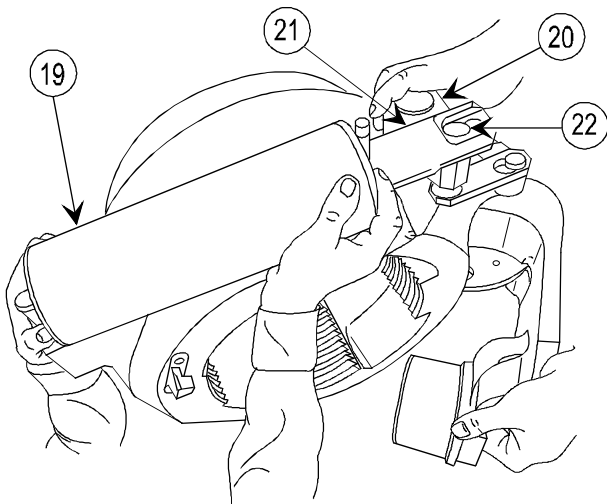

14 Close carrier (20) slowly until end of shaft (21) can be lifted clear of pin (22).

15 Remove breech counterbalance (19).

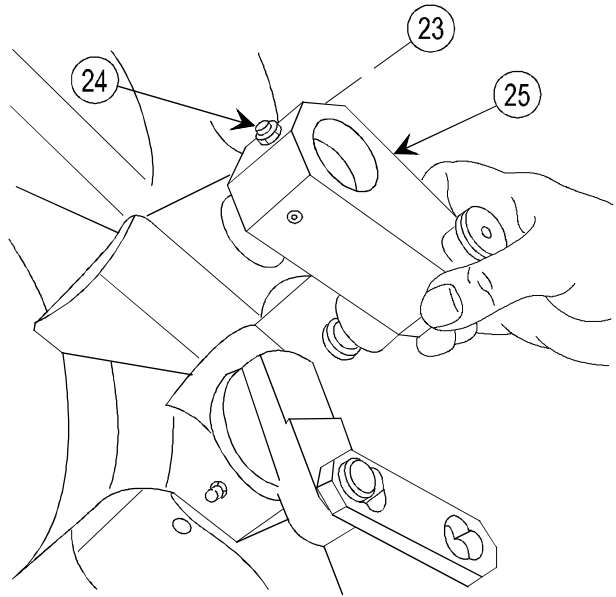

16 Remove spring pin (23), lubrication fitting (24), and arm (25).

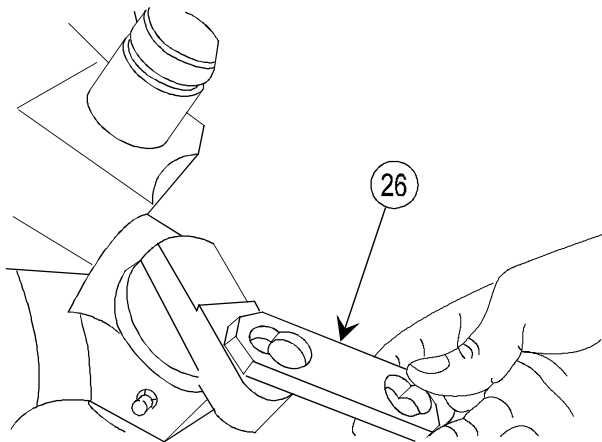

17 Remove rigid connecting link (26).

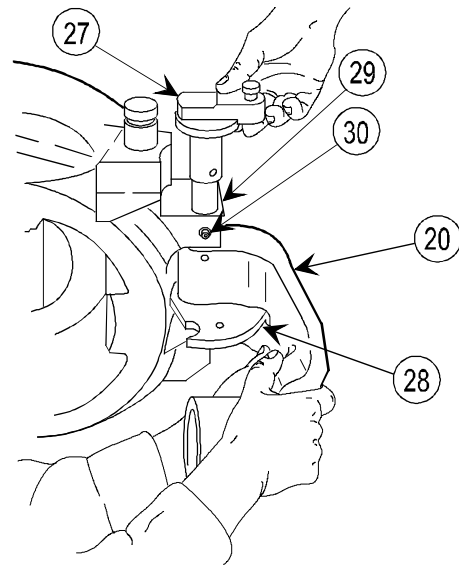

WARNING

To remove hinge pin (27) with cannon tube on weapon, cannon tube must be at zero elevation and then rotated counterclockwise to allow hinge pin to clear cradle assembly (p 2-23). Breech will fall out if not at zero elevation.

NOTE

Prior to removing hinge pin (27), note exact position of hinge pin to the carrier (20) and the block lock (28).

18 While supporting carrier (20), lift hinge pin (27) out of breech ring assembly (29).

19 Remove lubrication fitting (30).

2-9. BREECH MECHANISM ASSEMBLY—MAINTENANCE INSTRUCTIONS (cont)

DISASSEMBLY (cont)

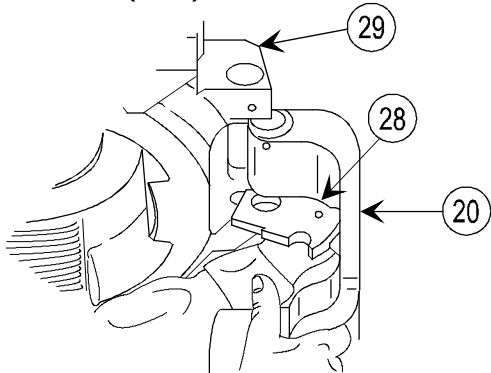

20 Remove carrier (20) and block lock (28) from breech ring assembly (29).

REASSEMBLY

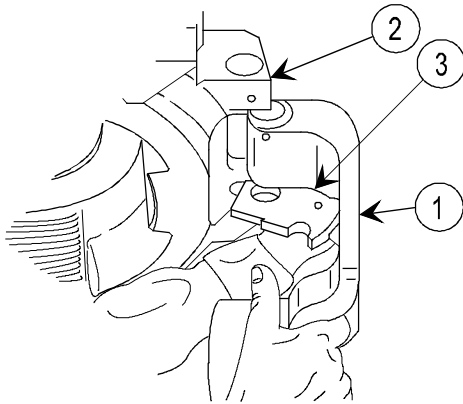

- 1** Install carrier (1) in breech ring assembly (2).
- 2** Install block lock (3) in exact position as in disassembly, aligning hole with hole in carrier (1).

INSPECTION/REPAIR

- 1** Check for broken, damaged, or missing parts.
- 2** Repair is by replacement of authorized parts (TM 9-1025-211-34P).
- 3** If breech ring assembly is damaged, replace entire breech mechanism assembly.

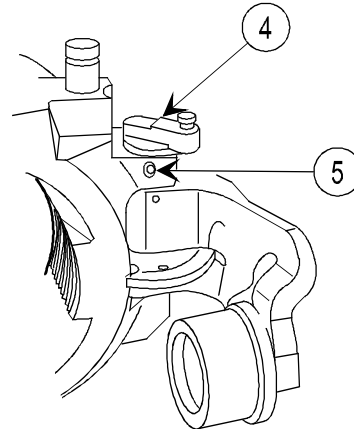

- 3** Install hinge pin (4).
- 4** Install lubrication fitting (5).

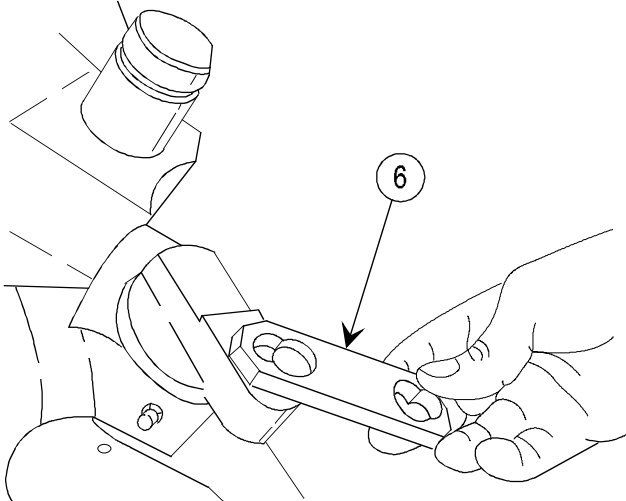

5 Install rigid connecting link (6).

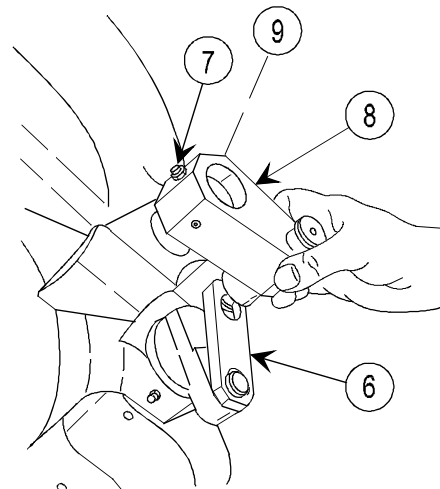

6 Install lubrication fitting (7), arm (8), and spring pin (9). Connect arm (8) to rigid connecting link (6).

- 7 Install breech counterbalance (10).

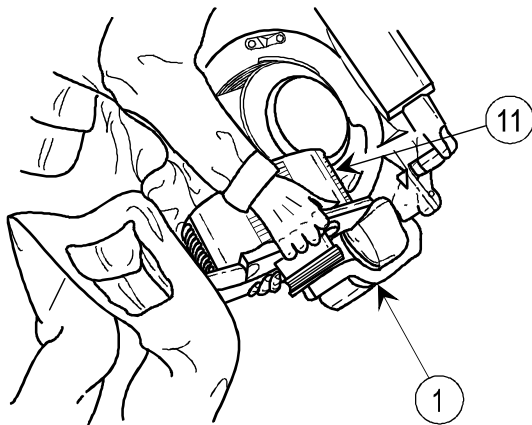
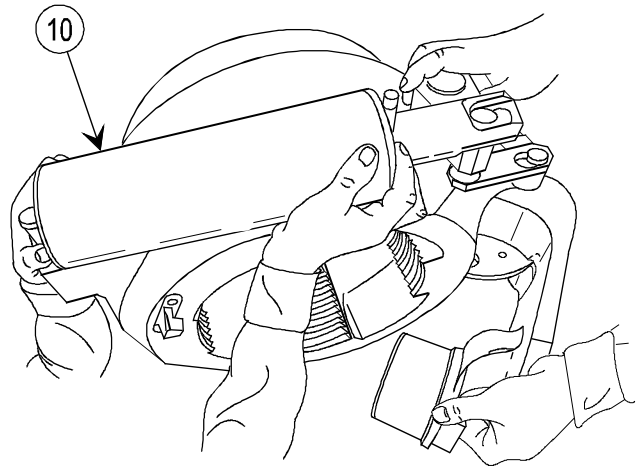

WARNING
Breechblock assembly weighs 128 lb (58 kg). Use care when removing or installing.

- 8 Place breechblock assembly (11) in position on carrier (1).

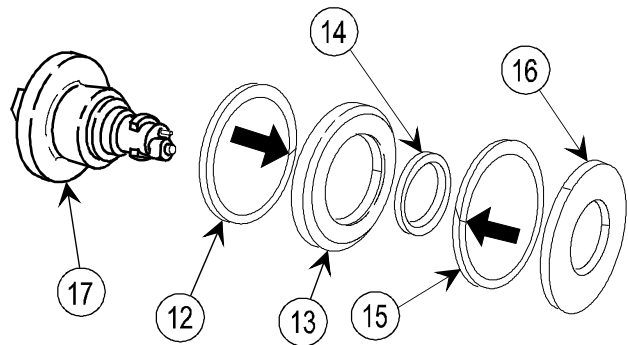

- 9 Assemble front split ring (12), obturator pad (13), inner ring (14), rear split ring (15), and disk (16) on obturator spindle assembly (17) with splits in front split ring (12) and rear split ring (15) approximately 180 degrees apart.

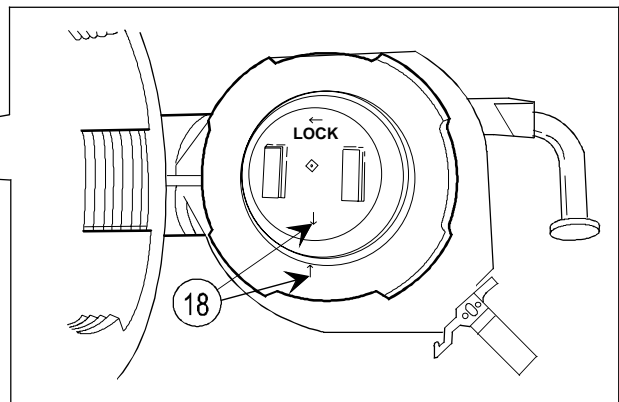
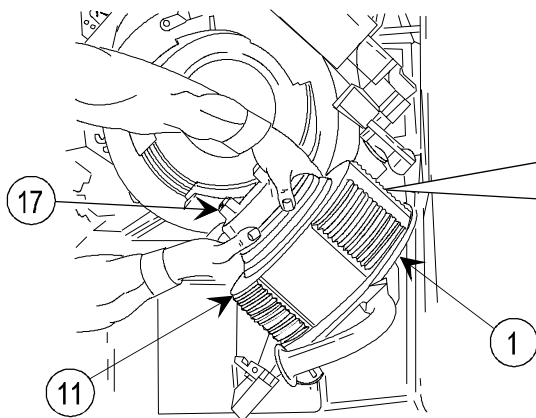

- 10 Install obturator spindle assembly (17) and parts in center of breechblock assembly (11) and carrier (1) with arrows (18) aligned.

2-9. BREECH MECHANISM ASSEMBLY—MAINTENANCE INSTRUCTIONS (cont)

REASSEMBLY (cont)

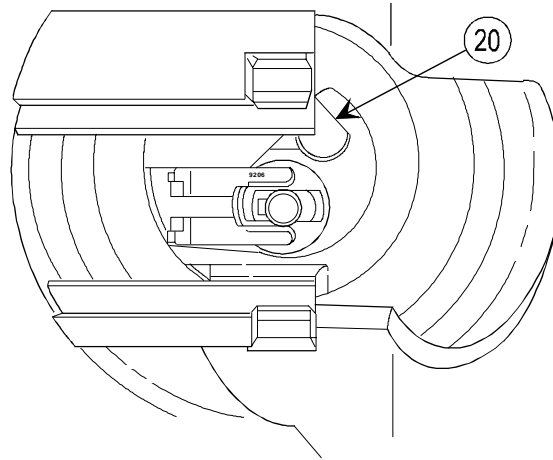
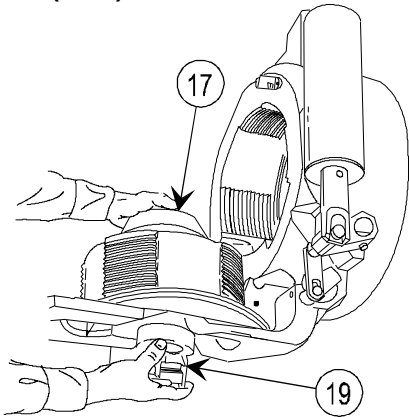

11 Place housing assembly (19) in position.

12 While supporting housing assembly (19), turn obturator spindle assembly (17) counterclockwise until it engages to a definite stop. Ensure that plunger (20) is in full locked position.

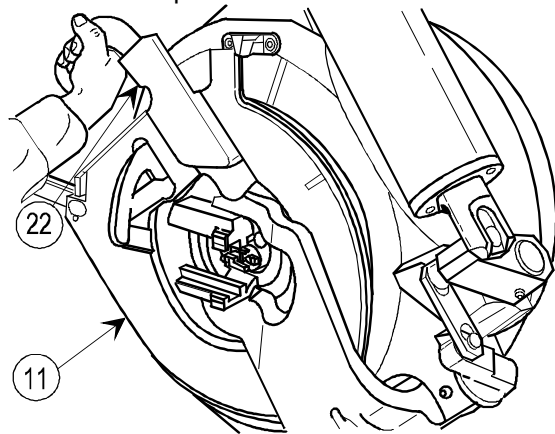
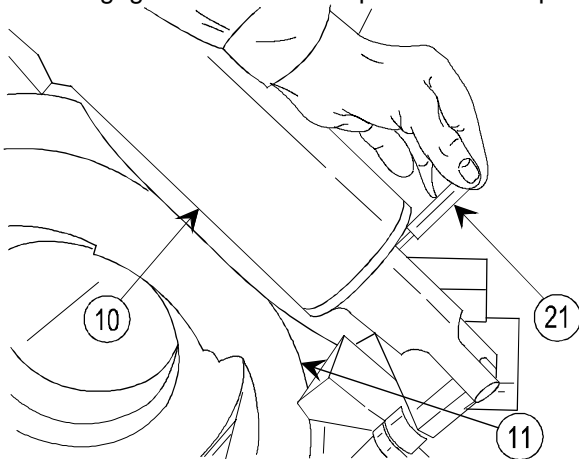

13 Remove pin (21) by pushing breechblock assembly (11) fully open and lifting pin out of hole in breech counterbalance (10).

14 Using handle (22), close breechblock assembly (11) but do not rotate. (Leave slot in horizontal position.)

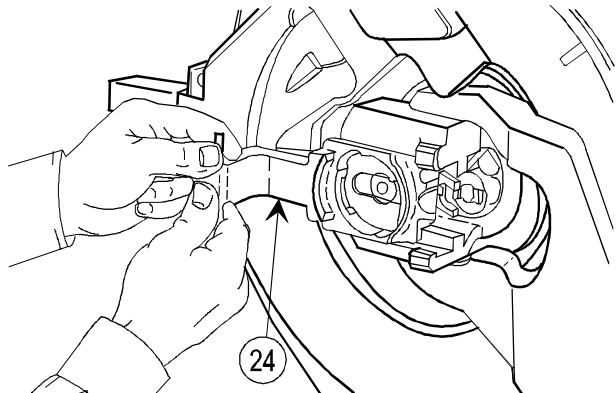
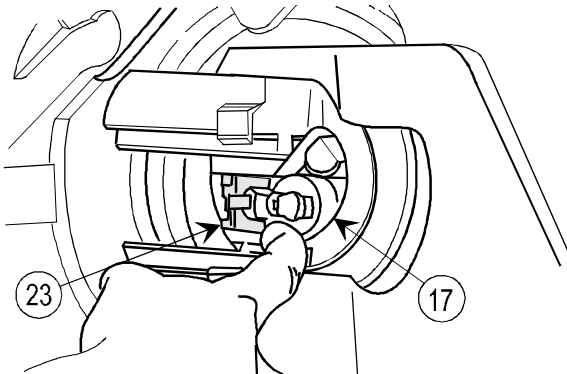

15 Push cartridge extractor (23) against end of obturator spindle assembly (17).

16 Install firing mechanism block assembly (24) and slide to the left.

- 17 Install firing mechanism assembly (25) by placing in position in firing mechanism block assembly (24). Press in, and turn counter-clockwise.
- 18 Push down handle (22) until breechblock assembly is closed.

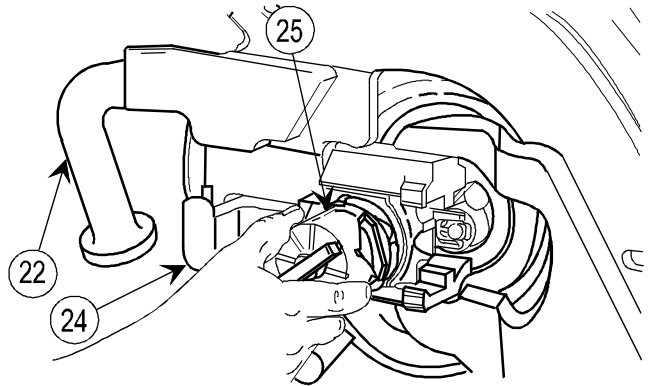

INSTALLATION

WARNING

Breech mechanism assembly weighs 930 lb (422 kg). Use care when removing or installing.

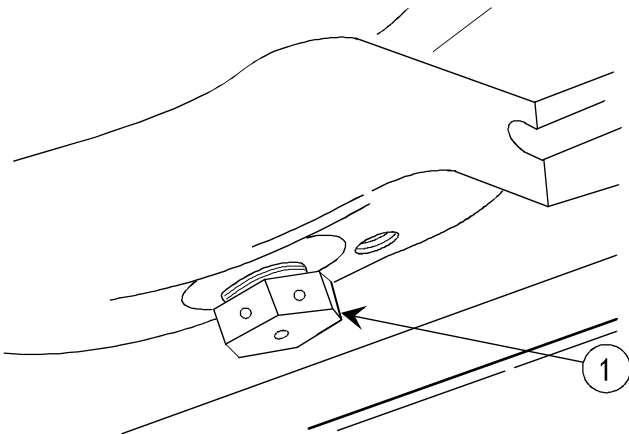

- 1 Partially install tube lock key (1).

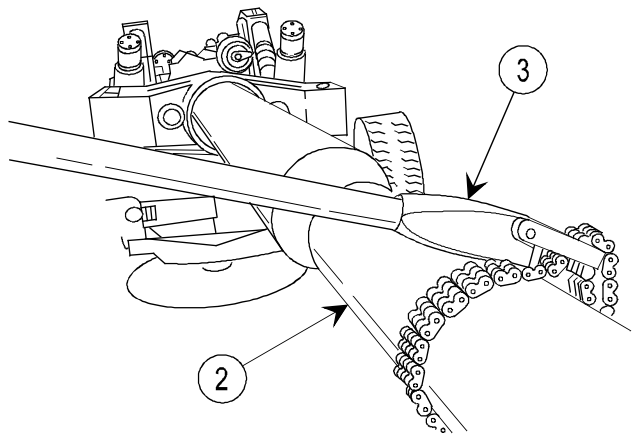

- 2 Hold cannon tube (2) in place with tube wrench (3).

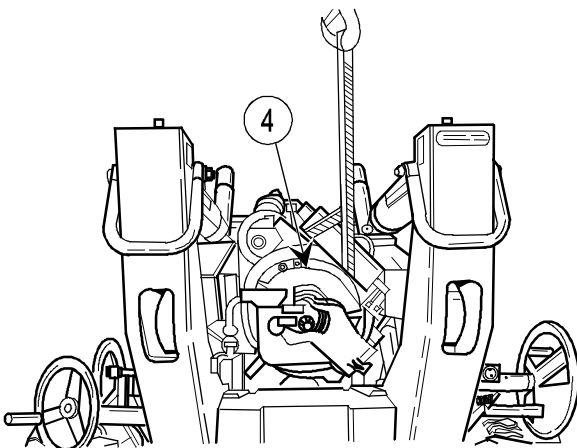

- 3 Assemble breech mechanism assembly (4) to cannon and rear yoke. Rotate breech mechanism assembly clockwise 1/8 turn, and remove slings.

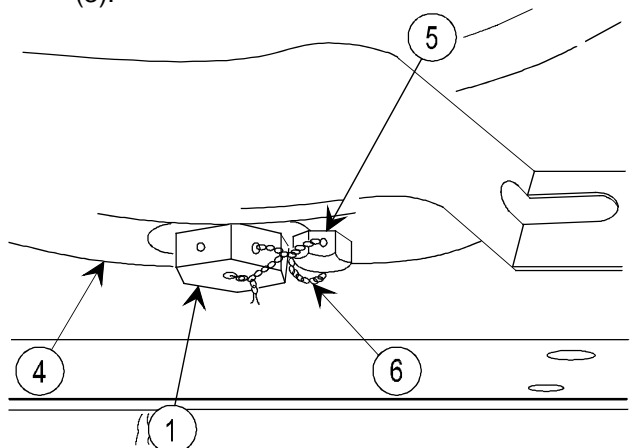

- 4 Install tube lock key (1) and capscrew (5) in breech mechanism assembly (4) and lock wire (6).

2-9. BREECH MECHANISM ASSEMBLY—MAINTENANCE INSTRUCTIONS (cont)

INSTALLATION (cont)

- 5 Install torque key (7) and capscrew (8) in breech mechanism assembly (4) and lock wire.

NOTE

Fire control alignment tests and measurements (TM 9-1025-211-10) must be performed and appropriate adjustments made (TM 9-1025-211-20&P).

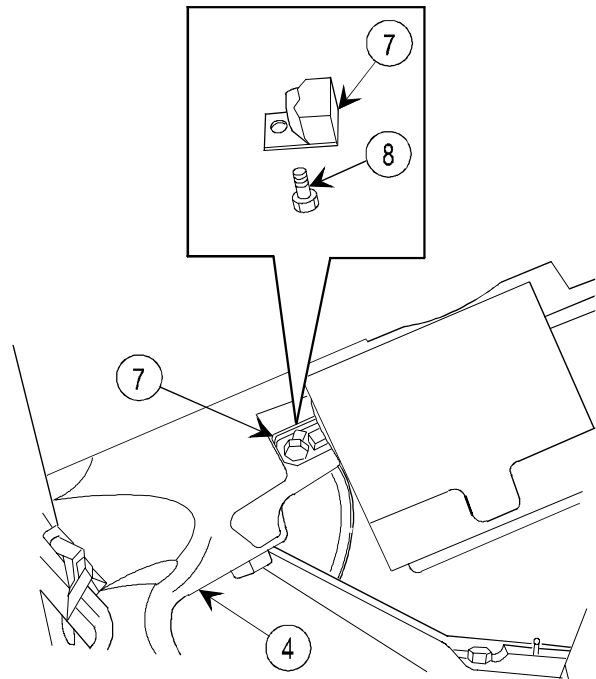

SECTION IV. M45 RECOIL MECHANISM MAINTENANCE INSTRUCTIONS

Section Index

Paragraph	Section Index	Page
2-10.	M45 Recoil Mechanism—Maintenance Instructions.....	2-58
2-10.1.	Replenisher Cylinder Assembly—Repair Instructions	2-88
2-11.	Replenisher Cylinder Assembly—Maintenance Instructions	2-88.6
2-12.	Sleeve Bearing Assembly—Maintenance Instructions	2-95
2-13.	Recoil Cylinder Assemblies—Maintenance Instructions	2-100
2-14.	Recuperator Cylinder Assembly and Parts—Maintenance Instructions	2-111
2-15.	Air Cylinder Assembly—Maintenance Instructions	2-129
2-16.	Oil Valve Assembly—Maintenance Instructions	2-134
2-17.	Front Yoke—Maintenance Instructions	2-136
2-18.	Middle Yoke—Maintenance Instructions	2-136.1
2-18.1.	M45 Recoil Mechanism Exerciser—Exercise Instructions	2-136.2

2-10. M45 RECOIL MECHANISM—MAINTENANCE INSTRUCTIONS

THIS TASK COVERS:

- a. Lowering nitrogen pressure in recoil mechanism
- b. Deleted
- c. Charging recoil mechanism with nitrogen pressure when air cylinder assembly, recuperator cylinder assembly, or replenisher cylinder assembly is replaced.
- d. Filling recoil mechanism with oil and purging oil of air
- e. Alternate method — Filling recoil mechanism with oil and purging oil of air
- f. Leak detection
- g. Draining oil reserves
- h. Removal
- i. Inspection/repair
- j. Installation
- k. Adjustment

INITIAL SETUP

Tools and Special Tools

Air pressure gage assembly (MILG8348)	Nitrogen tank (BBN411)
Artillery field maintenance shop equipment (SC 4933-95-CL-A12)	Recoil hose assembly (8432575)
Eyebolt (2) (MS51937-13)	Safety strut assembly (12008900)
Hydraulic M3 pump kit (7122378)	Spanner wrench (12008906)
Liquid release tool assembly (8410594)	Spanner wrench (12008910)
M45 recoil mechanism purging tools (figure C-22)	Spanner wrench (12008909)
M198 field artillery repairman tool kit (5911278)	3-ton hoist
Nitrogen charging kit (8449334)	
Nitrogen hose assembly (12008918)	

NOTE

Disposal of hydraulic fluid must be in accordance with local, state, and federal regulation.

Materials/Parts

Abrasive cloth (item 8, appx B)
Cleaning compound (item 7, appx B)
Cotter pin (3) (MS24665-283)
Cotter pin (2) (MS24665-362)
Drip pan
5-gallon container
General purpose lubricating oil (item 15, appx B)
Lock wire (item 34, appx B)
Lock wire (item 35, appx B)
Oil (hydraulic fluid) (item 14, appx B)
Preformed packing (MS28775-011)
Preformed packing (2) (MS28778-12)
Soap (item 30, appx B)
Tape (item 32, appx B)
Wiping rag (item 22, appx B)

Personnel Required: 2
Artillery repairmen

References

TM 9-1025-211-10
TM 9-1025-211-20&P
TM 9-1025-211-34P
TM 9-4933-201-15P

NOTE

The following equipment conditions apply to recoil mechanism removal only.

Equipment Conditions

- 2-23 M199 cannon removed
 - 2-23 M45 recoil mechanism ballistic shield removed
 - 2-23 Safety strut assemblies attached
- Blocking available

General Safety Instructions

WARNING

All lifting devices must be checked in accordance with local Standing Operating Procedure (SOP) to make sure they are in good working condition before starting the lifting operation.

2-10. M45 RECOIL MECHANISM—MAINTENANCE INSTRUCTIONS (cont)

LOWERING NITROGEN PRESSURE IN RECOIL MECHANISM

WARNING

Nitrogen under pressure is dangerous. Eye protection must be worn throughout this procedure.

CAUTION

Service recoil mechanism nitrogen pressures at ambient temperature of weapon use.

NOTE

Short recoil cycles and slamming into battery are indications that recoil mechanism is overcharged with nitrogen.

The following procedures may be performed with M199 cannon and recoil mechanism ballistic shield installed.

- 1 Remove cap (1) from recuperator cylinder assembly (2).

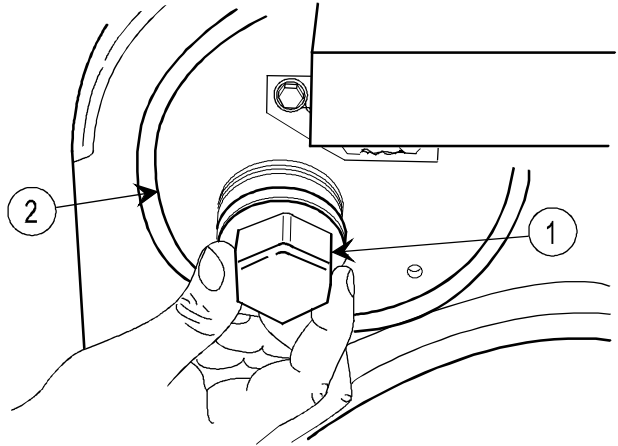

- 2 Remove valve cap (3) from check valve (4).

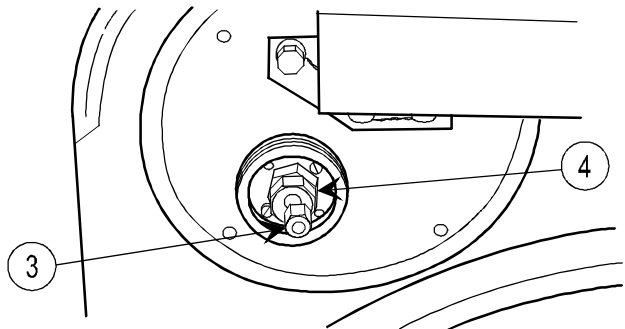

NOTE

Prior to connecting nitrogen checking device (5) to check valve (4), check for nitrogen leakage. This can eliminate the check valve as a possible source of leakage if pressure is low.

- 3 Connect nitrogen checking device (5) to check valve (4) and open check valve (4) slowly.

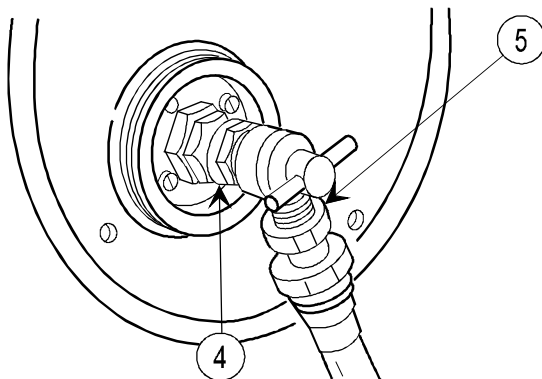

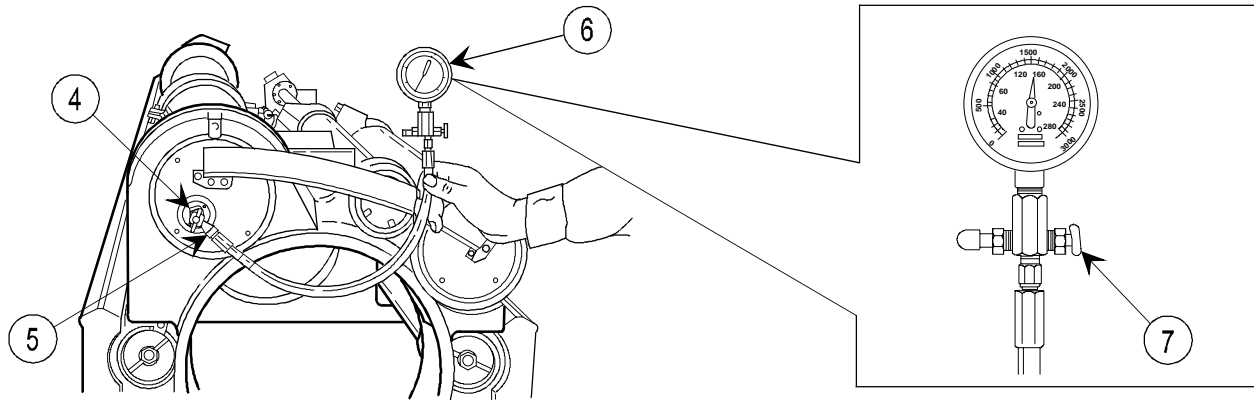

- 4 Read nitrogen pressure of recoil mechanism on gage (6).
- 5 If pressure reading on gage (6) exceeds 1100 psi (7585 kPa) at ambient temperature, open bleeder valve (7) until gage reads 1100 + 25 psi (7585 + 174 kPa) at ambient temperature; then close.
- 6 Close check valve (4).
- 7 Open bleeder valve (7).
- 8 Disconnect nitrogen checking device (5) from check valve (4).

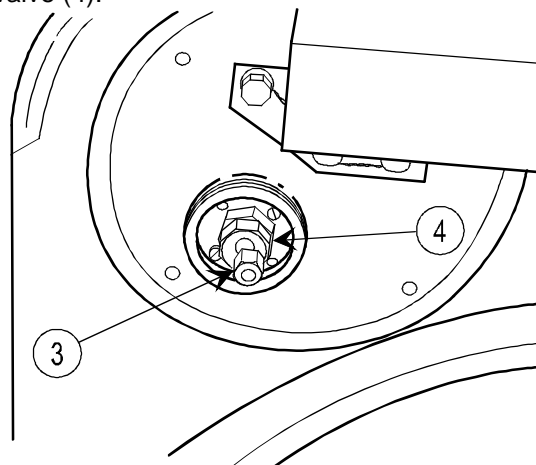
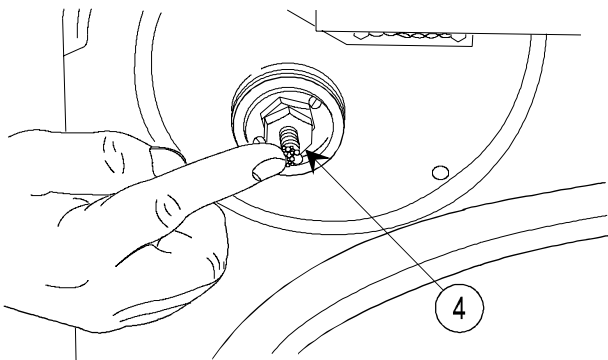

- 9 Apply soap suds to determine if any nitrogen leaks are present.
- 10 If any leaks occur, tighten check valve (4).

NOTE

Check preformed packing with soap suds before replacing check valve (4).

- 11 If leaks still occur, bleed nitrogen pressure (p 2-58) and replace check valve (4) (p 2-111).
- 12 Install valve cap (3).
- 13 Install cap (1).

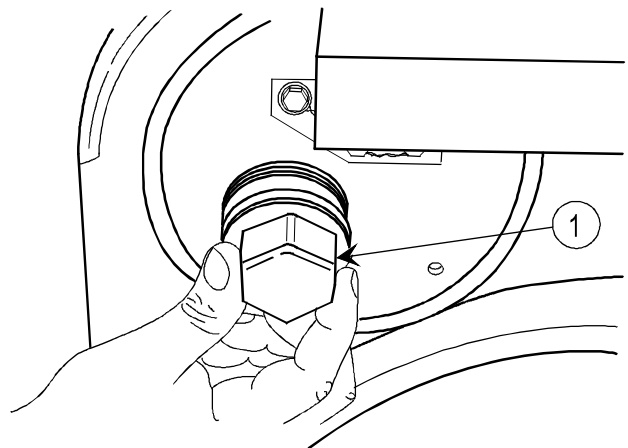

NOTE

All data on pages 2-62 thru 2-64 deleted.

**CHARGING RECOIL MECHANISM WITH NITROGEN PRESSURE WHEN AIR CYLINDER ASSEMBLY,
RECUPERATOR CYLINDER ASSEMBLY, OR REPLENISHER CYLINDER ASSEMBLY ARE REPLACED**

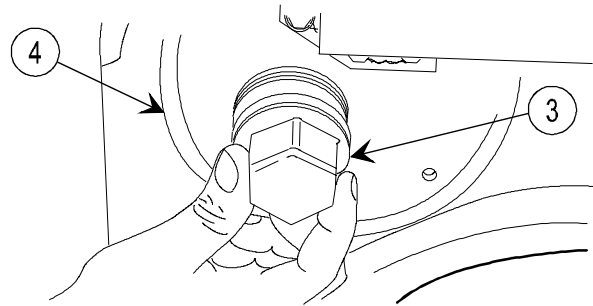
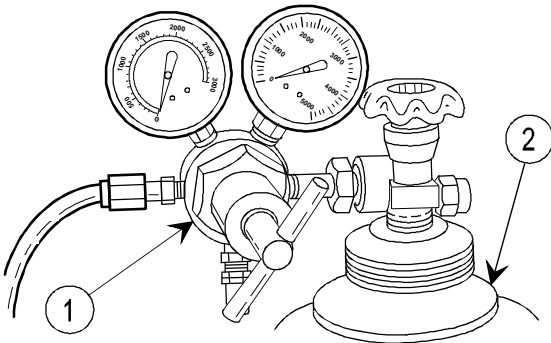

WARNING

Nitrogen under pressure is dangerous. Eye protection must be worn throughout this procedure.

CAUTION

Open and close nitrogen tank valve to clear valve seat of any dust or dirt. Repeat operation after installation of pressure regulator to clear hose.

NOTE

Recoil mechanism may be serviced on or off howitzer. If serviced on howitzer, M199 cannon need not be removed. Before charging recoil mechanism, refer to purging and filling procedure on page 2-71.

- 1 Connect pressure regulator (1) to nitrogen tank (2).
- 2 Remove cap (3) on recuperator cylinder assembly (4).

2-10. M45 RECOIL MECHANISM—MAINTENANCE INSTRUCTIONS (cont)

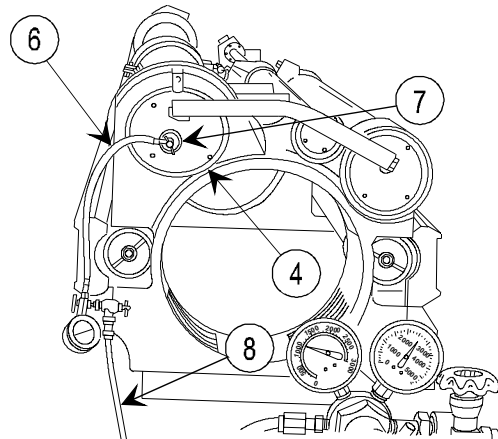
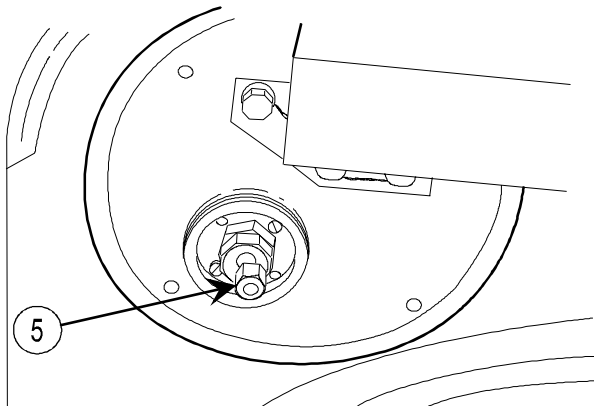

- 3 Remove valve cap (5).
- 4 Connect nitrogen checking device (6) to check valve (7) on recuperator cylinder assembly (4).
- 5 Connect nitrogen charging device (8) to nitrogen checking device (6).
- 6 Open check valve (7) by turning counterclockwise.

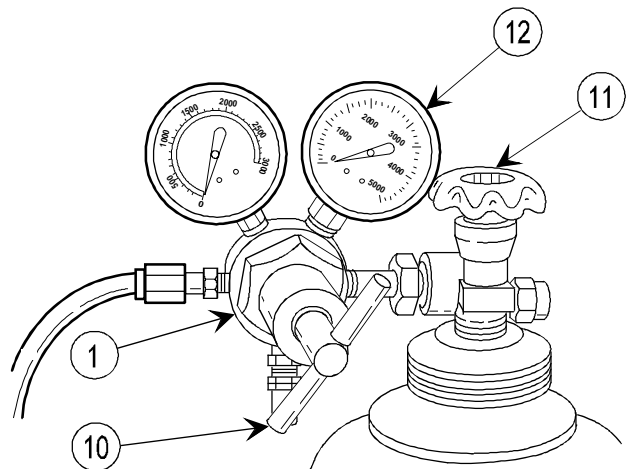
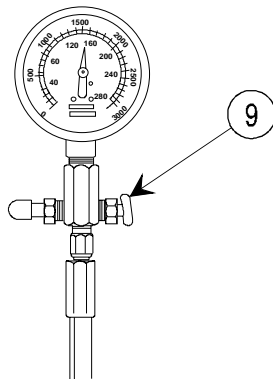

- 7 Close bleeder valve (9).
- 8 Close pressure regulator valve (10), turning counterclockwise until no spring pressure is applied.
- 9 Open valve (11) slowly until full bottle pressure is indicated on 4000-psi gage (12) of pressure regulator (1).
- 10 Open pressure regulator valve (10) slowly, turning clockwise until pressure on 3000-psi gage (13) registers 50 psi (345 kPa).

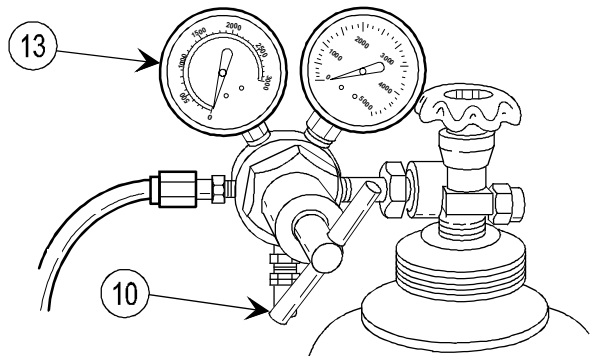

- 11 Open valve (14), allowing nitrogen to enter the recuperator cylinder assembly (4) until gage (15) on nitrogen checking device (6) reads 50 psi (345 kPa). Close valve (14).
- 12 Open bleeder valve (9) until all nitrogen is bled from recuperator cylinder assembly (4). Close bleeder valve (9).
- 13 Open valve (14).
- 14 Repeat steps 10 thru 13 two times to remove all traces of moisture prior to charging system with nitrogen.

CAUTION

Charging the system too fast will heat the dry nitrogen. This will give an inaccurate reading because the pressure will decrease when the nitrogen cools.

NOTE

More than one nitrogen tank will be required to charge recuperator cylinder assembly. Estimated time to charge system is 30 minutes or more. System should be charged at ambient temperature of weapon use.

- 15 Open pressure regulator valve (10) slowly, allowing nitrogen to charge system. Raise pressure at 100 psi (690 kPa) increments until gage (13) stabilizes at 1300 psi (8964 kPa).

WARNING

Failure to close check valve (7) on recuperator cylinder assembly (4) could result in injury.

- 16 Close check valve (7) and let system sit for 1 hour after charging.

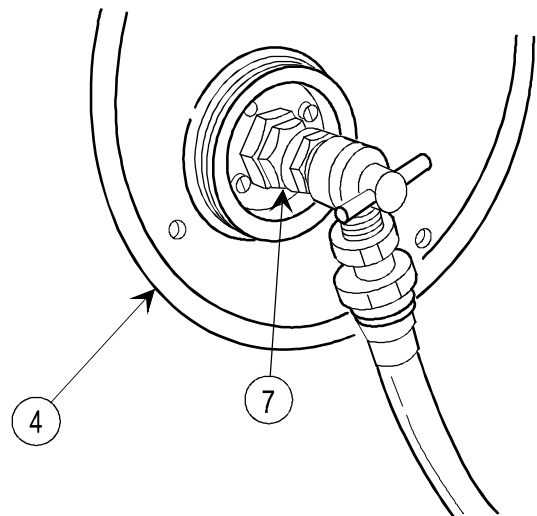
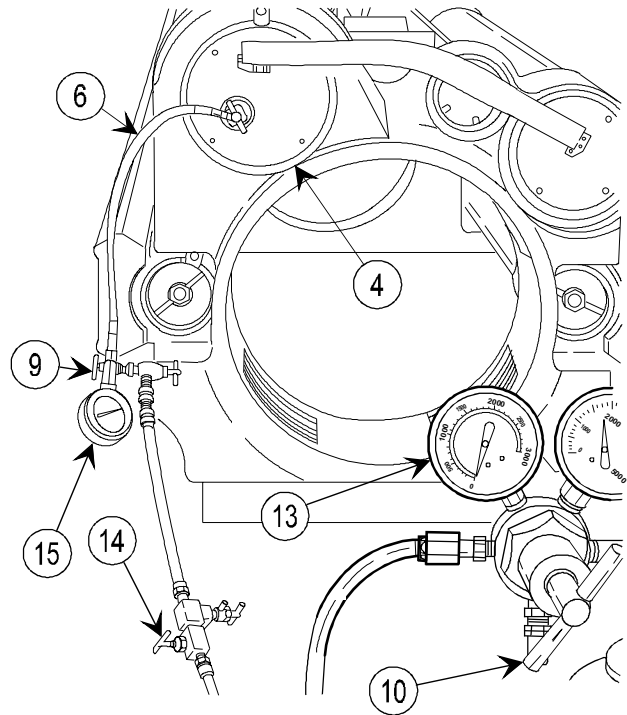

2-10. M45 RECOIL MECHANISM—MAINTENANCE INSTRUCTIONS (cont)

CHARGING RECOIL MECHANISM WITH NITROGEN PRESSURE WHEN AIR CYLINDER ASSEMBLY, RECUPERATOR CYLINDER ASSEMBLY, OR REPLENISHER CYLINDER ASSEMBLY ARE REPLACED (cont)

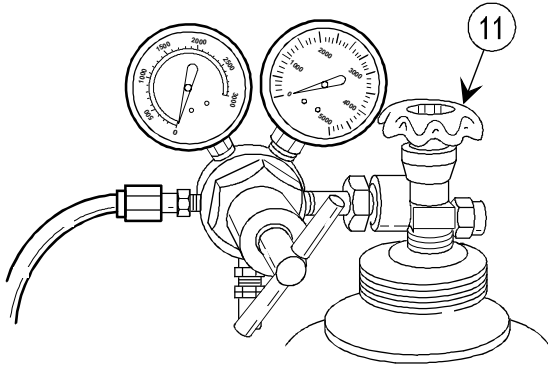

17 Close valve (11).

WARNING
Failure to open the bleeder valve (9) could result in injury.

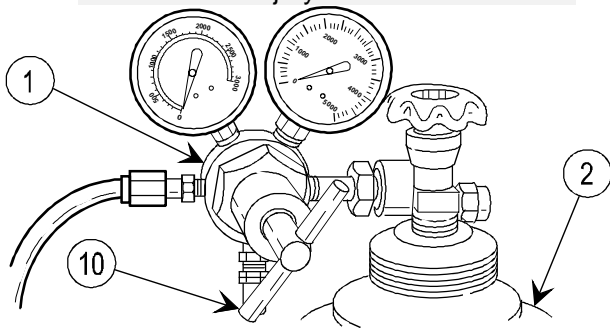

19 Close pressure regulator valve (10) by turning counterclockwise.

20 Disconnect pressure regulator (1) from nitrogen tank (2).

22 Close check valve (7).

23 Disconnect nitrogen checking device (6) from check valve (7) on recuperator cylinder assembly (4).

24 Apply soap suds to check valve (7) to determine any nitrogen leaks. If leaks occur, tighten.

NOTE
Check preformed packing before replacing check valve.

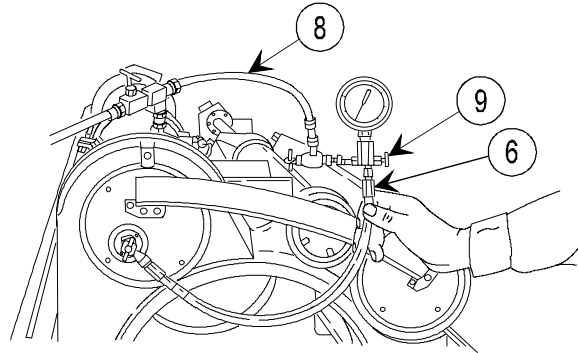

18 Open bleeder valve (9) to bleed pressure from nitrogen charging device (8) and nitrogen checking device (6), and disconnect nitrogen charging device (8) from nitrogen checking device (6).

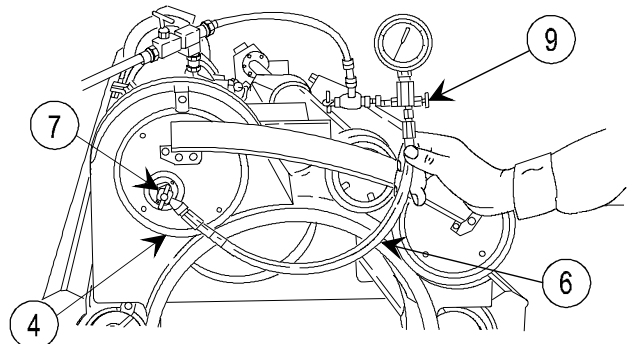

21 With nitrogen checking device (6), close bleeder valve (9). Open check valve (7) on recuperator cylinder assembly (4). Slowly open bleeder valve (9) to regulate recuperator cylinder assembly pressure to 1100 + 25 psi (7585 + 174 kPa).

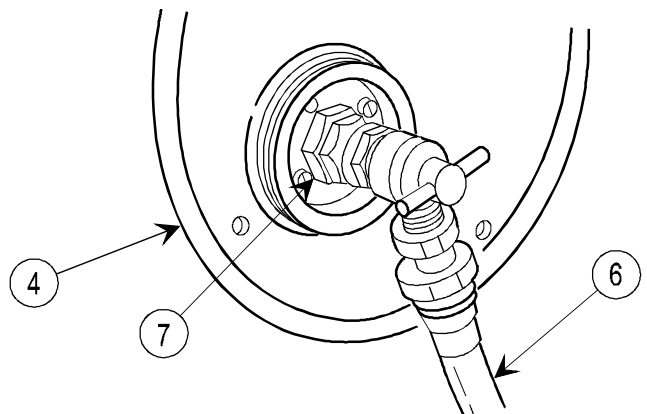

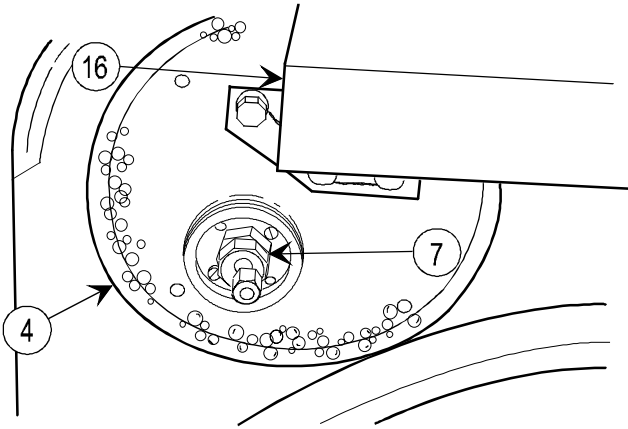

- 25 If leaks still occur, release nitrogen pressure (p 2-58) and replace check valve (p 2-111).
- 26 Apply soap suds to recuperator cylinder assembly (4) to determine any nitrogen leaks. If leaks occur, replace recuperator cylinder assembly (p 2-111).
- 27 Remove cover (16) (p 2-111).

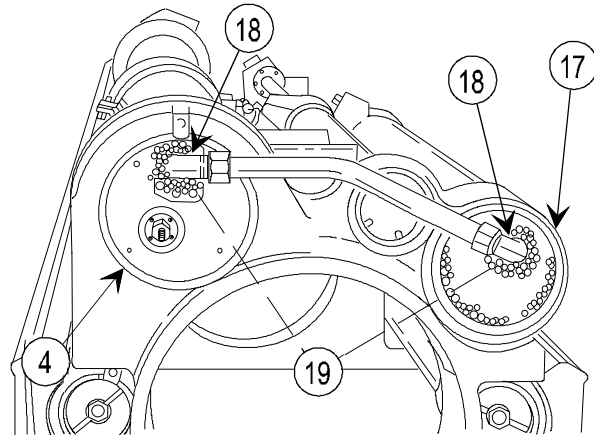

- 28 Apply soap suds to air cylinder assembly (17) and elbows (18) on recuperator cylinder assembly (4) to determine any nitrogen leaks. If leaks occur around elbows, replace preformed packings (19) (p 2-111 or 2-129). If leaks occur around air cylinder assembly, replace it (p 2-111).

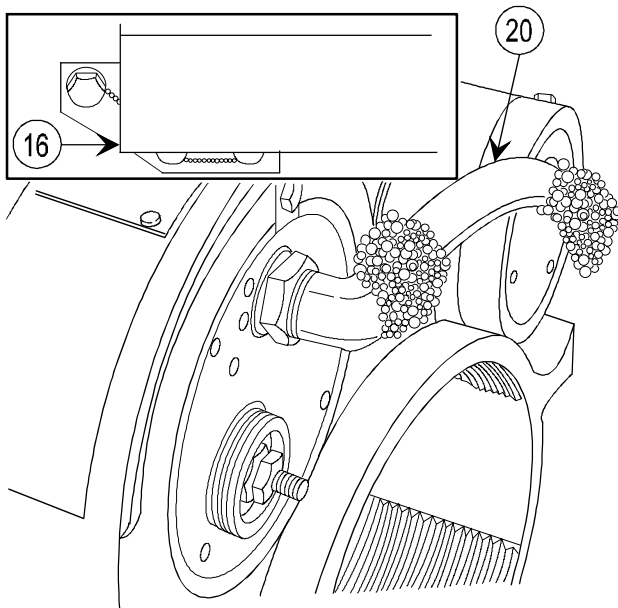

- 29 Apply soap suds to nuts on tube (20) to determine any nitrogen leaks. If leaks occur, tighten. If leaks still occur, replace tube (p 2-129).
- 30 Install cover (16) (p 2-111).

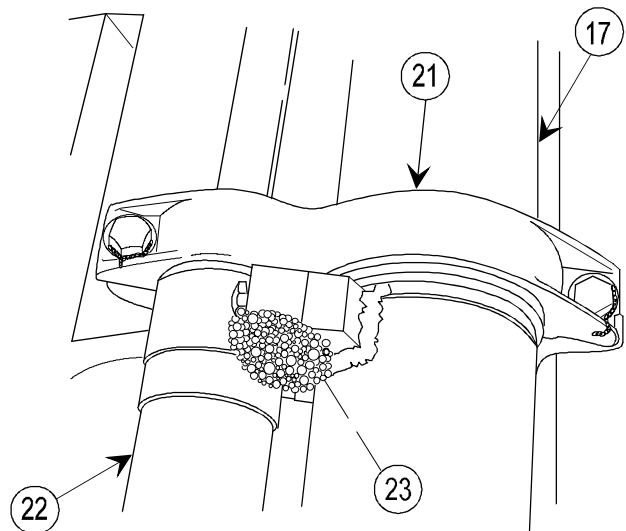

- 31 Apply soap suds to middle yoke (21) between air cylinder assembly (17) and replenisher cylinder assembly (22) to determine any nitrogen leaks. If leaks occur, replace preformed packing (23) (p 2-88).

2-10. M45 RECOIL MECHANISM—MAINTENANCE INSTRUCTIONS (cont)

CHARGING RECOIL MECHANISM WITH NITROGEN PRESSURE WHEN AIR CYLINDER ASSEMBLY, RECUPERATOR CYLINDER ASSEMBLY, OR REPLENISHER CYLINDER ASSEMBLY ARE REPLACED (cont)

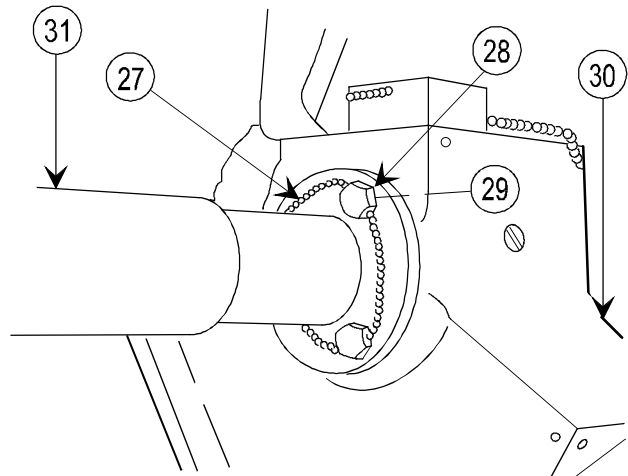
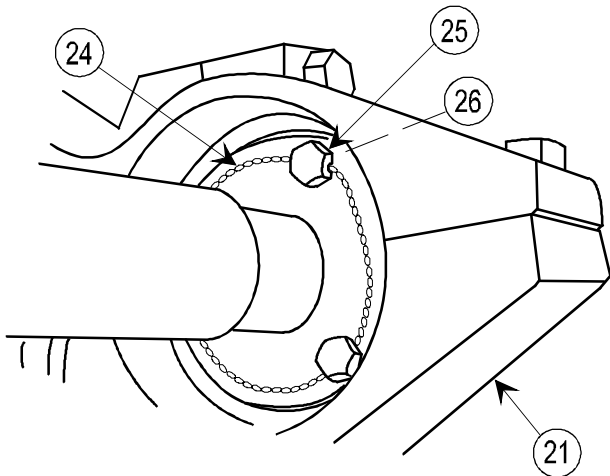

NOTE

Oil reserves must be bled from recoil to remove cover (p 2-58).

- 32** Remove lock wire (24), three cap screws (25), and lockwashers (26) from front of middle yoke (21).

- 33** Remove lock wire (27), three cap screws (28), and lockwashers (29) from rear of front yoke (30). Remove indicator cover (31) from replenisher.

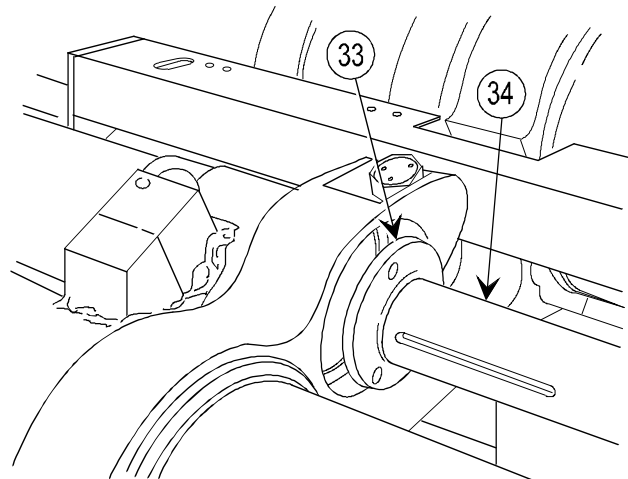
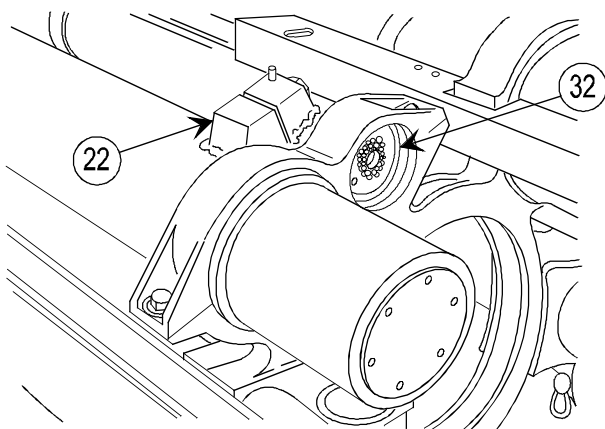

- 34** Apply soap suds to determine any nitrogen leaks.
- 35** Replace replenisher cylinder assembly (22) if nitrogen pressure leaks from end assembly (32).

- 36** Install sleeve bushing (33) and oil reserve indicator (34) so that scale on oil reserve indicator (34) is visible from right side of weapon.
- 37** Make sure slot on sleeve bushing (33) lines up with slot in oil reserve indicator (34).

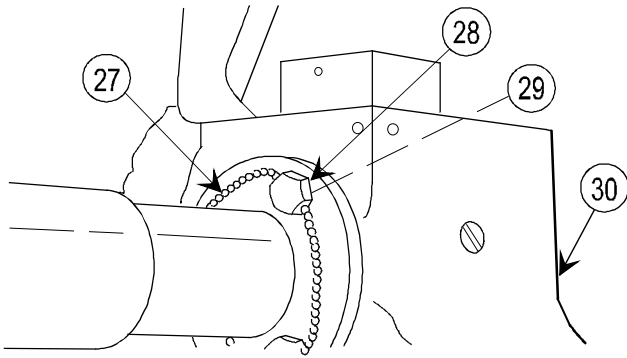

38 Install three lockwashers (29) and capscrews (28) and tighten in rear of front yoke (30). Apply 8 ± 1 ft-lb (11 ± 1 N-m) of torque to capscrews (28).

39 Install lock wire (27) (item 34, appx B).

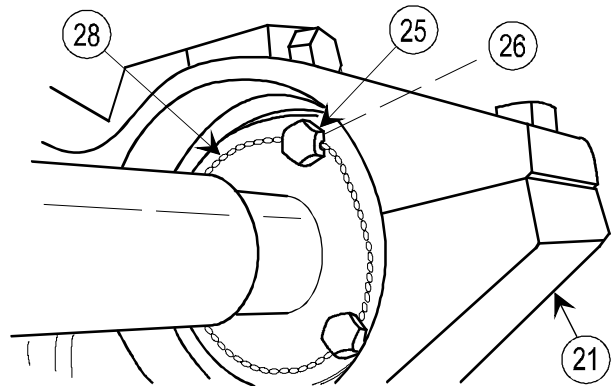

40 Install three lockwashers (26) and capscrews (25), and tighten in front of middle yoke (21). Apply 8 ± 1 ft-lbs (11 ± 1 N-m) of torque to capscrews (25).

41 Install lock wire (28) (item 34, appx B).

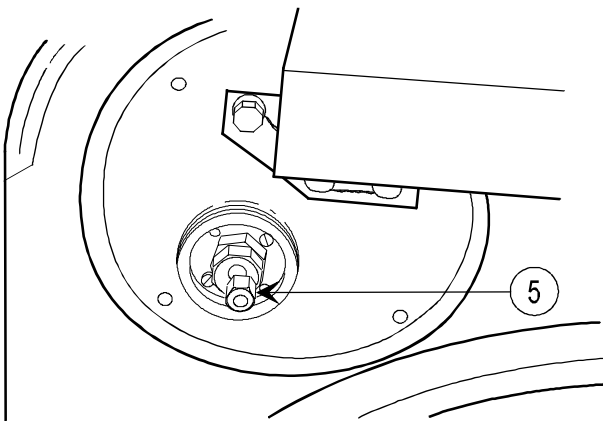

42 Install valve cap (5).

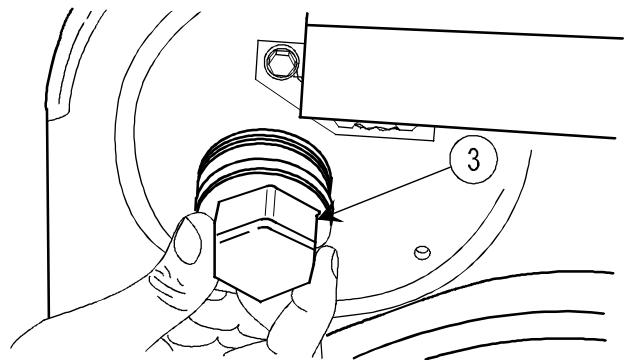

43 Install cap (3).

FILLING RECOIL MECHANISM WITH OIL AND PURGING OIL OF AIR

WARNING

If recoil mechanism is installed on the howitzer during purge procedures, the recoil and M199 cannon must be secured in place to ensure that the recoil mechanism does not slide out of battery when oil reserves are bled.

NOTE

Make sure the M3 oil pump has a supply of oil (TM 9-1025-211-20&P) at all times during purging and filling procedures.

Recoil mechanism may be on or off weapon for following procedures. The procedures will cover raising or lowering the recoil mechanism with sling and hoist.

Steps 1 thru 14 are considered the preliminary purging procedures prior to charging the system.

1 Level the recoil mechanism.

2-10. M45 RECOIL MECHANISM—MAINTENANCE INSTRUCTIONS (cont)

FILLING RECOIL MECHANISM WITH OIL AND PURGING OIL OF AIR (cont)

- 2 Unscrew plug (1) and remove from oil valve assembly (2).

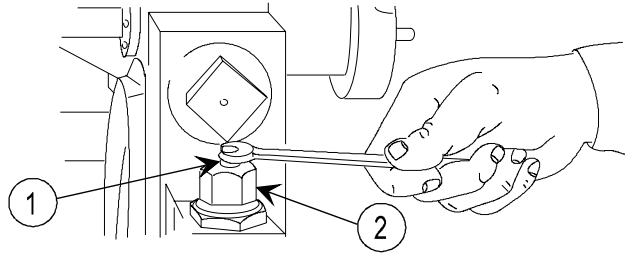

NOTE

Adapter (3) is the 5/8-18 UNF adapter from the hydraulic M3 pump kit.

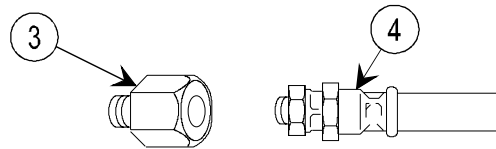

- 3 Connect adapter (3) to oil line (4) on M3 oil pump (5).

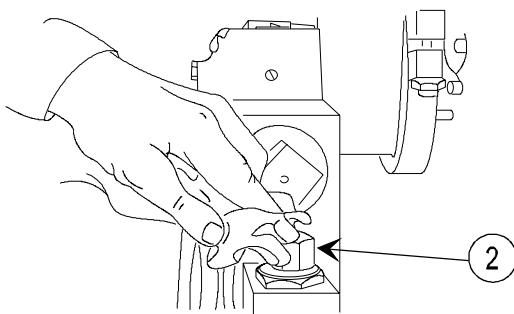
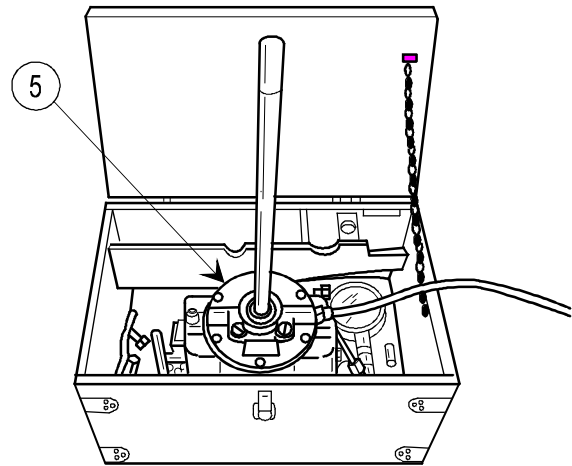

- 4 Clean recess in oil valve assembly (2) with wiping rag.

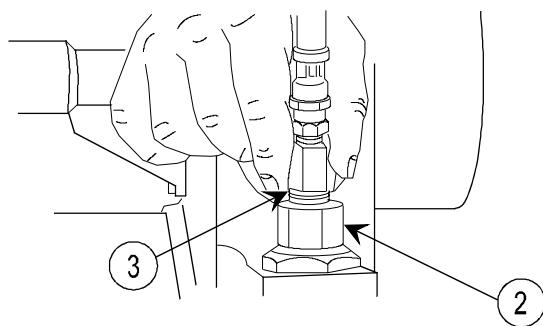

- 5 Insert adapter (3) and handtighten into oil valve assembly (2).
- 6 Purge air from oil line (4) by operating M3 oil pump (5) until no bubbles appear at adapter (3) and oil valve assembly (2). Tighten adapter (3).

- 7 Remove setscrew (6) and gasket (7) from purge hole (8) on each recoil cylinder assembly (9).

NOTE

Air/oil may not flow from purge hole (8) due to manufacturing process change. If air/oil does not flow from purge hole (8), reinstall gasket (7) and setscrew (6). Purging must be accomplished through the front yoke purge port.

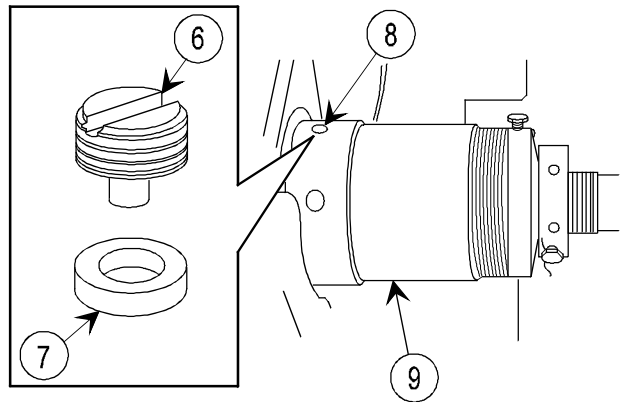

- 8 Operate M3 oil pump (5) until oil from purge hole (8) is clear and no trapped air is present.
- 9 Install new gasket (7) and setscrew (6) in purge hole (8) of each recoil cylinder assembly (9).

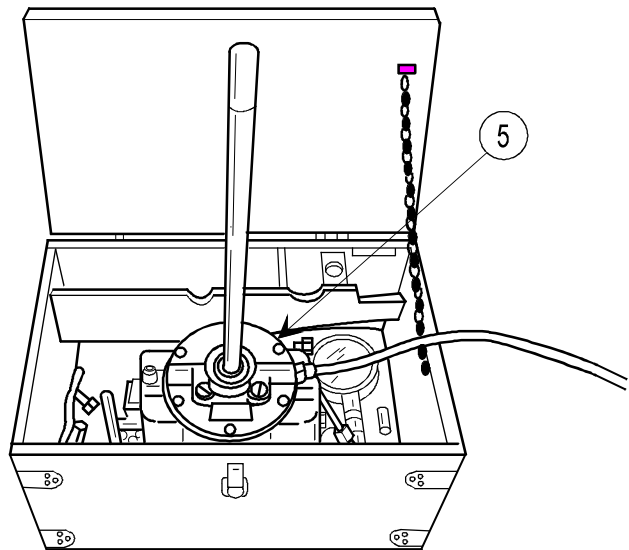

- 10 Remove setscrew (10) and gasket (11) from replenisher cylinder assembly purge hole (12).

NOTE

Ensure gaskets are removed from purge holes before installing purge pipes. Gaskets will either plug the purge pipe and not allow oil to flow or be forced into the cylinder.

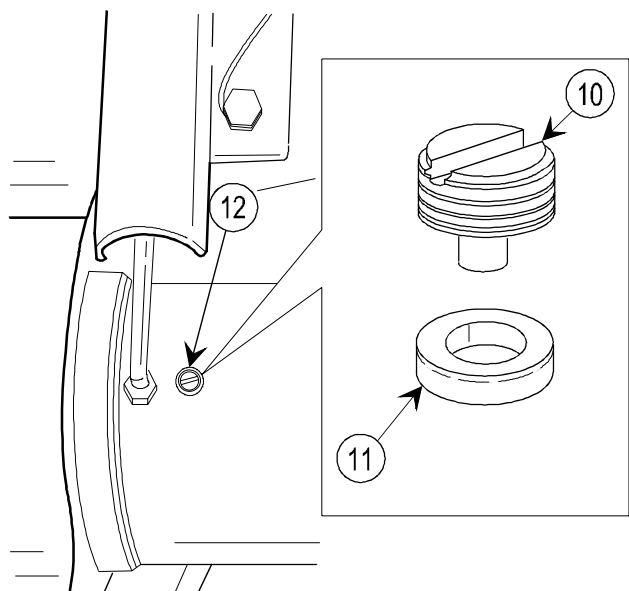

2-10. M45 RECOIL MECHANISM—MAINTENANCE INSTRUCTIONS (cont)

FILLING RECOIL MECHANISM WITH OIL AND PURGING OIL OF AIR (cont)

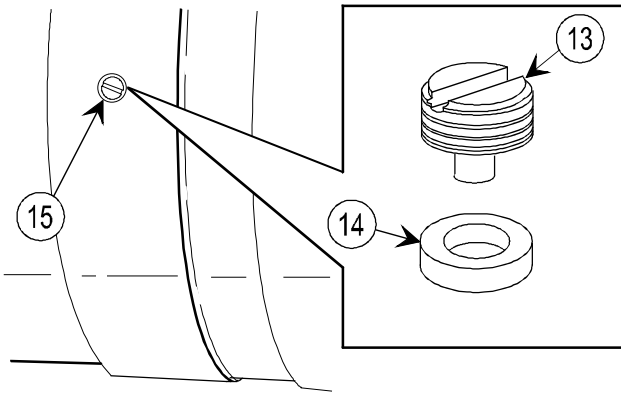

- 11** Remove setscrew (13) and gasket (14) from recuperator cylinder assembly purge hole (15).

NOTE

Ensure recoil mechanism is level.

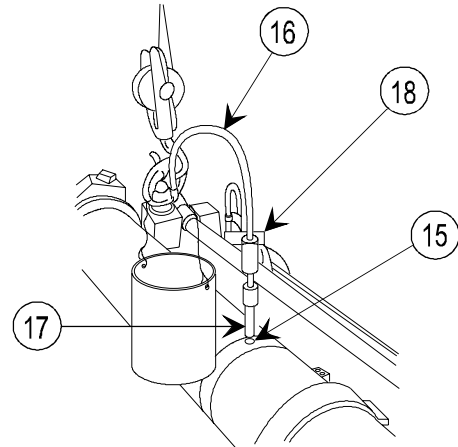

- 12** Wrap tape on threads of two purge pipes (16) and adapters (17), and install in replenisher cylinder assembly purge hole (12) and recuperator cylinder assembly purge hole (15).

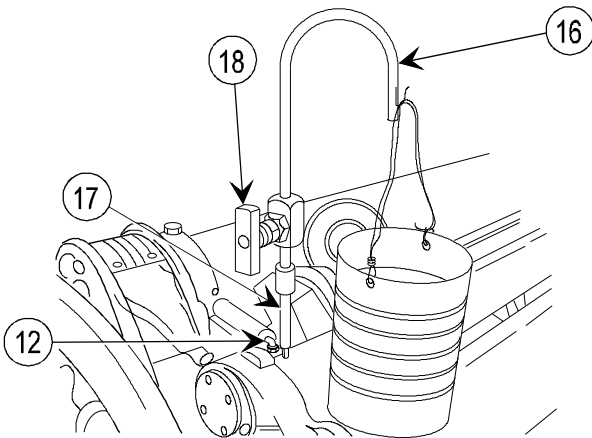

- 13** Open valves (18).
- 14** Operate M3 oil pump (5) until oil is coming from both purge pipes (16). Close valves (18).

NOTE

At this point, charge the system (p 2-58) and begin final purging.

- 15** Using M3 oil pump (5), pump in approximately three reserves as indicated on oil reserve indicator (19).

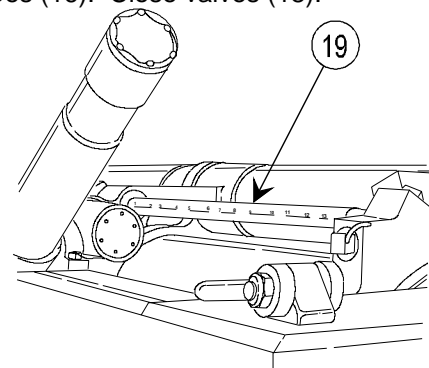
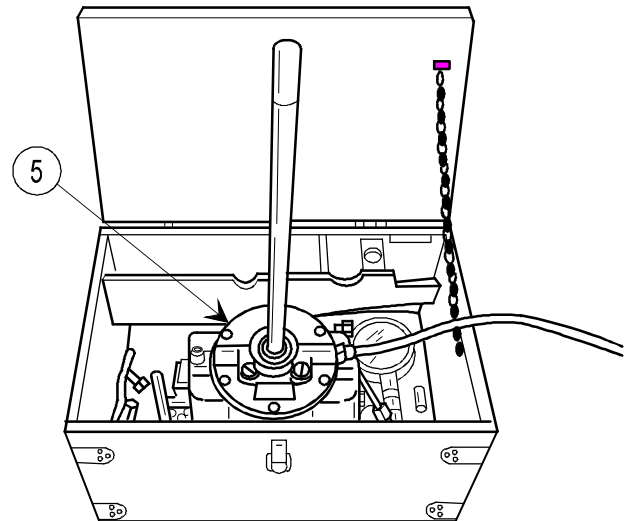

NOTE

When system is charged with reserves during the purging process, do not drain immediately. Let stand long enough to allow trapped air to move to purge port area of the cylinders.

- 16 Open valves (18).

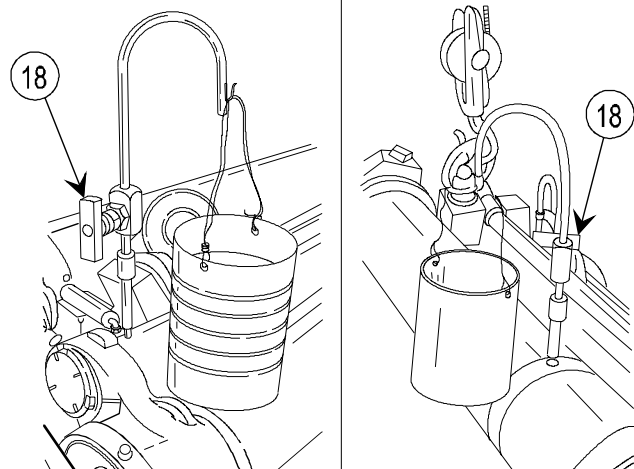

WARNING

If recoil mechanism is installed on the howitzer during purge procedure, the recoil mechanism and M199 cannon must be secured in place to ensure that they do not slide out of battery when oil reserves are bled.

NOTE

Drain reserves from the elevated purge pipe when performing steps 17 and 18.

- 17 Lower rear of recoil mechanism (20) approximately 12 in. (30 cm), using a sling (21) and 3-ton hoist (22).
- 18 Lower front of recoil mechanism (20) approximately 12 in. (30 cm), using sling (21) and 3-ton hoist (22).
- 19 Repeat steps 17 and 18 three times while performing steps 15 and 16 until all air is out of replenisher cylinder assembly.
- 20 Level recoil mechanism (20).

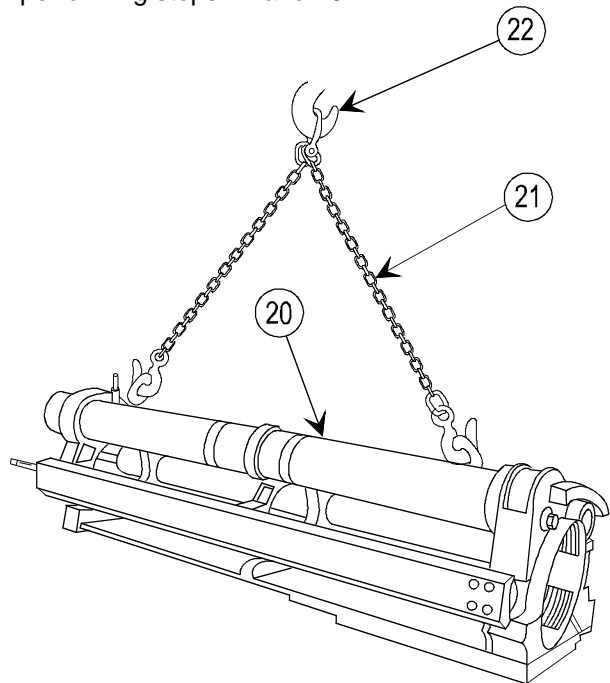

2-10. M45 RECOIL MECHANISM—MAINTENANCE INSTRUCTIONS (cont)

FILLING RECOIL MECHANISM WITH OIL AND PURGING OIL OF AIR (cont)

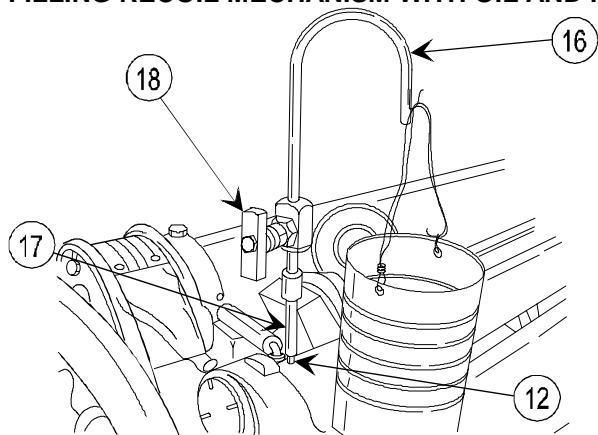

21 With valve (18) open, remove purge pipe (16) and adapter (17) from replenisher cylinder assembly purge hole (12).

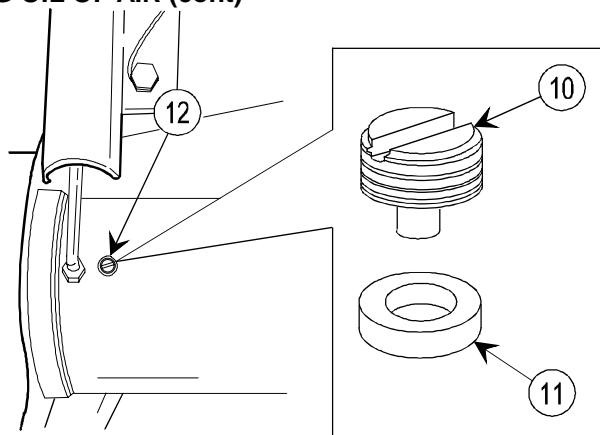

22 Install new gasket (11) and setscrew (10) in replenisher cylinder assembly purge hole (12).

NOTE

Ensure gaskets are removed from purge holes before installing purge pipes. Gaskets will either plug up the purge pipe and not allow oil to flow or be forced into the cylinder.

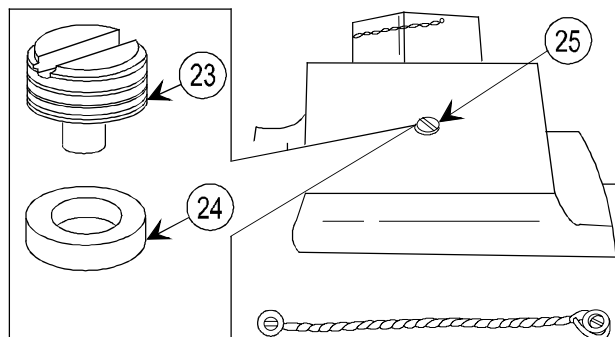

23 Remove setscrew (23) and gasket (24) from front yoke purge hole (25).

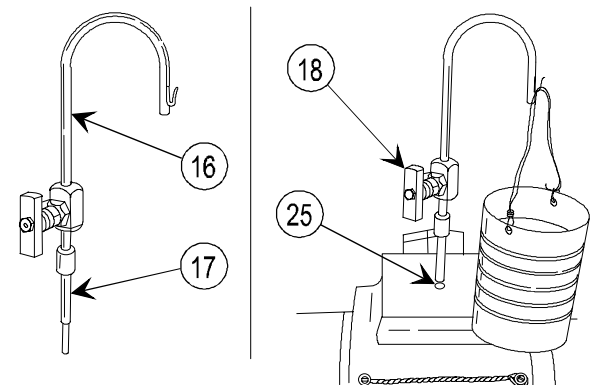

24 Wrap tape on threads of purge pipe (16) and adapter (17).

25 Install adapter (17) in front yoke purge hole (25) and hang can. Open valve (18).

26 Lower rear of recoil mechanism (20) approximately 12 in. (30 cm), using sling (21) and 3-ton hoist (22).

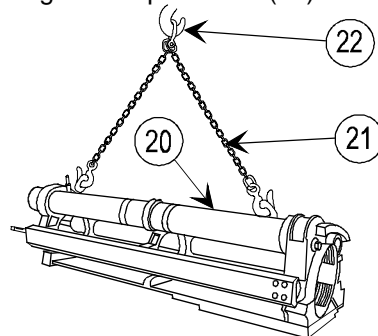

- 27 Close valves (18) in front yoke purge hole (25) and recuperator cylinder assembly purge hole (15).

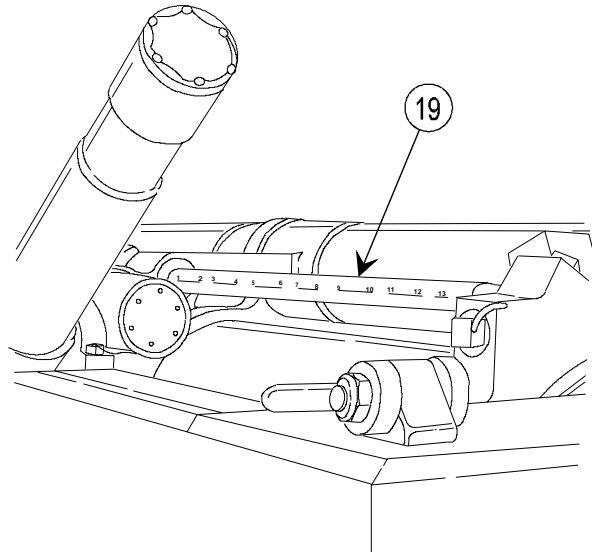
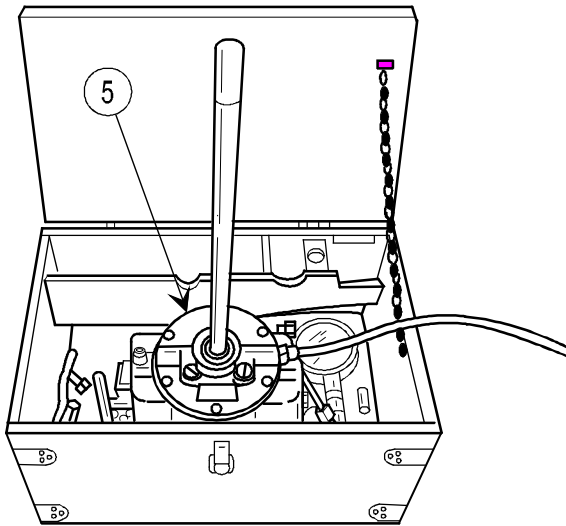
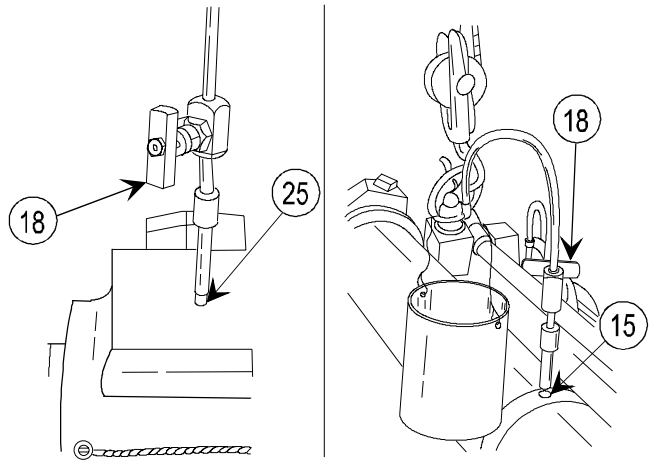

- 28 Operate M3 oil pump (5) until three reserves are indicated on oil reserve indicator (19).

NOTE

When system is charged with reserves during purging process, do not drain immediately. Let stand long enough to allow trapped air to move to purge port area of the cylinders.

- 29 Open one valve (18).

NOTE

Repeat steps 27 and 28 four times; alternate between valve (18) in recuperator cylinder assembly purge hole (15) and valve in front yoke purge hole (25) until all air is out of the system.

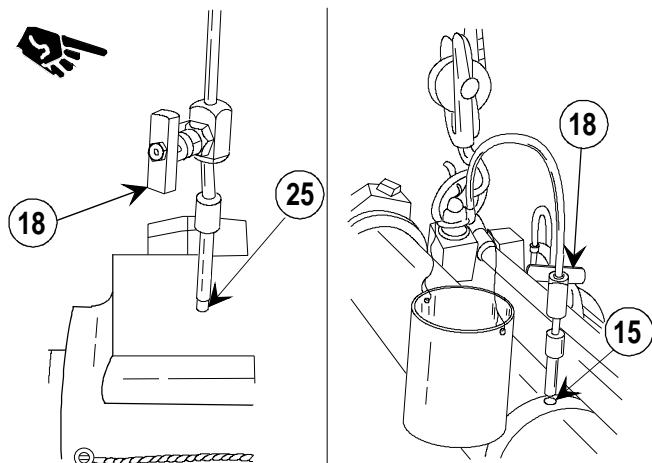

2-10. M45 RECOIL MECHANISM—MAINTENANCE INSTRUCTIONS (cont)

FILLING RECOIL MECHANISM WITH OIL AND PURGING OIL OF AIR (cont)

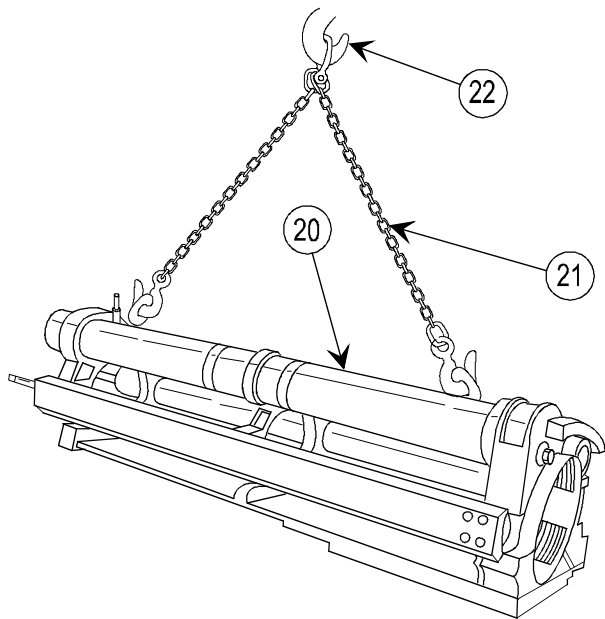

30 Level recoil mechanism (20) using a sling (21) and 3-ton hoist (22); then remove sling and 3-ton hoist.

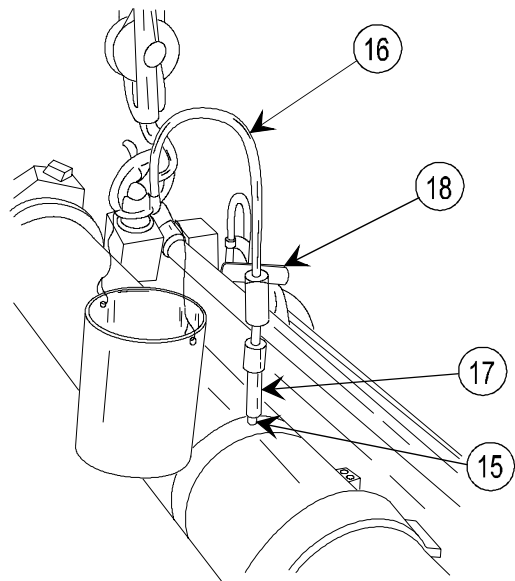

31 Open valve (18) and remove purge pipe (16) and adapter (17) from recuperator cylinder assembly purge hole (15).

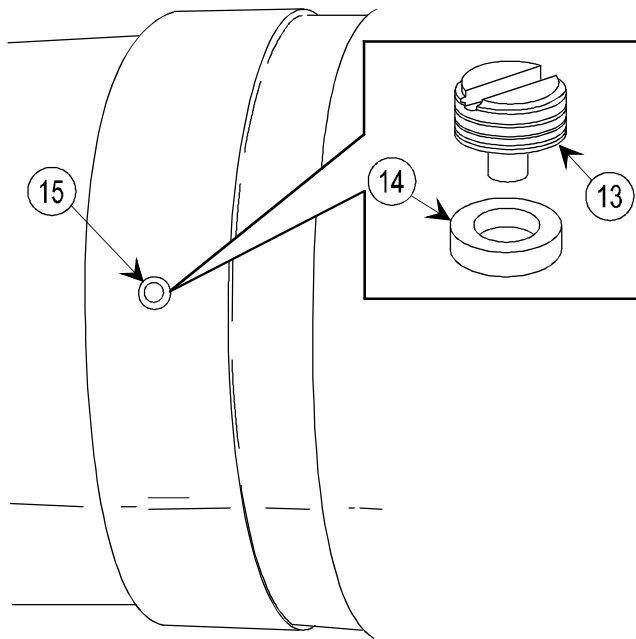

32 Install new gasket (14) and setscrew (13) in recuperator cylinder assembly purge hole (15).

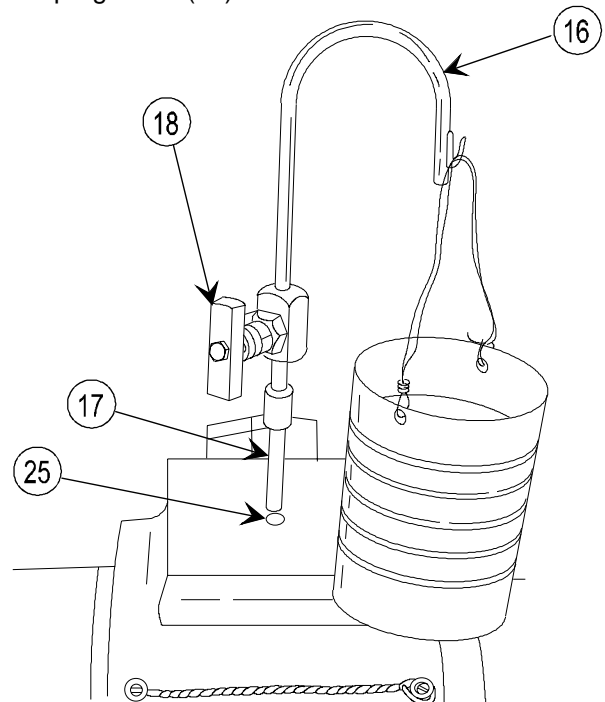

33 Open valve (18) and remove purge pipe (16) and adapter (17) from front yoke purge hole (25).

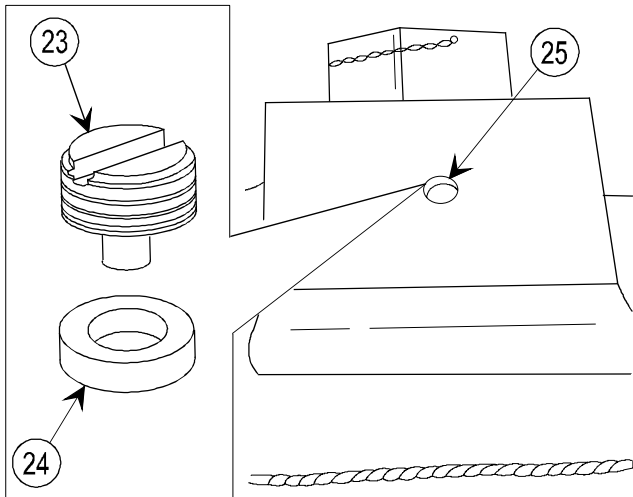

- 34 Install new gasket (24) and setscrew (23) in front yoke purge hole (25).

NOTE

It takes approximately 40 to 50 strokes to move oil reserve indicator one reserve.

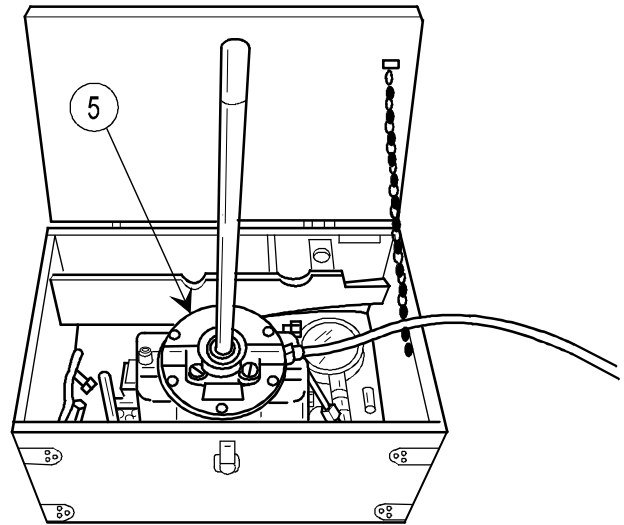

- 35 Using M3 oil pump (5), pump in four reserves.

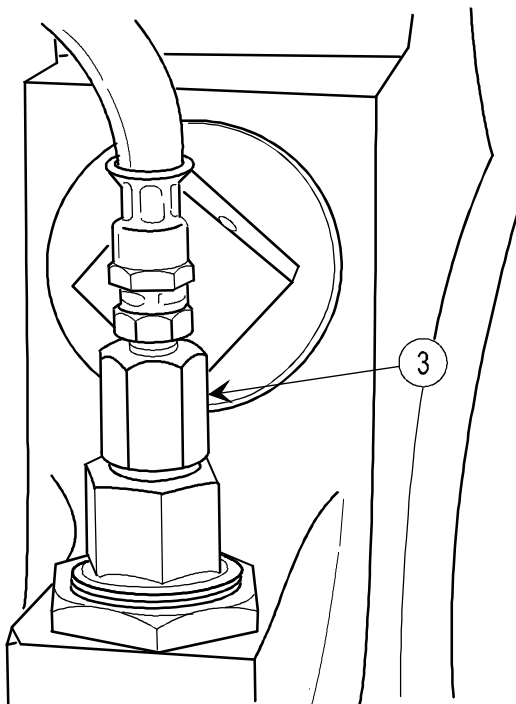

NOTE

Release pressure from M3 oil pump prior to disconnecting pump from oil filler valve.

- 36 Remove adapter (3) and M3 oil pump (5) and disassemble.

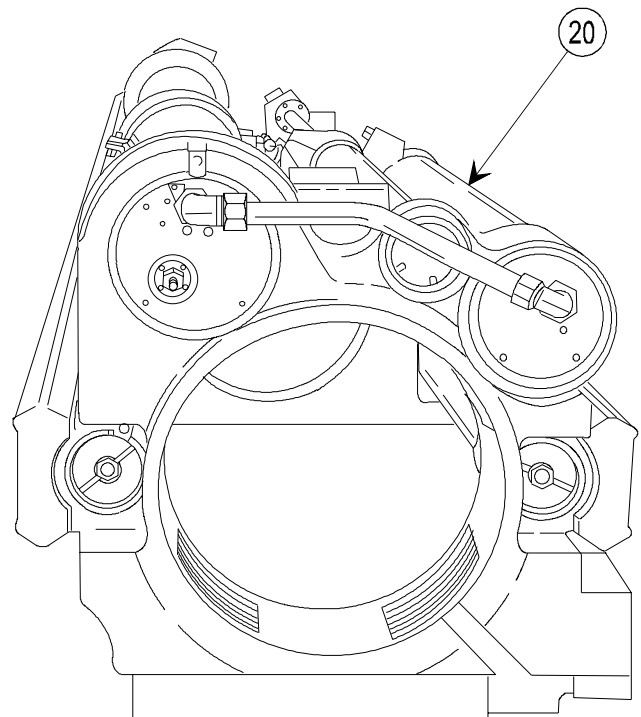

- 37 Inspect recoil mechanism (20) for leaks at this time.

2-10. M45 RECOIL MECHANISM—MAINTENANCE INSTRUCTIONS (cont)

FILLING RECOIL MECHANISM WITH OIL AND PURGING OIL OF AIR (cont)

- 38 Clean plug (1) recess with wiping rag and install.

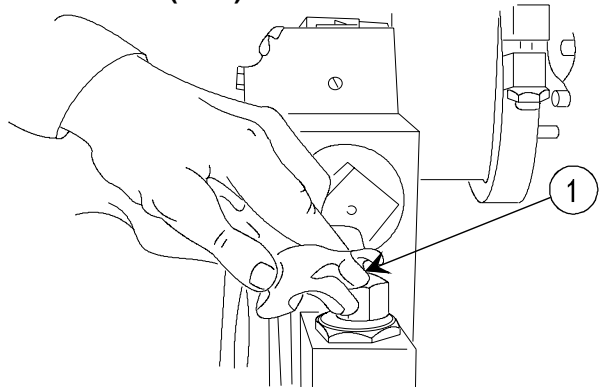

ALTERNATE METHOD—FILLING RECOIL MECHANISM WITH OIL AND PURGING OIL OF AIR

- 1 Level the recoil mechanism.
- 2 Install safety struts.
- 3 Remove plug (1) from oil valve assembly (2).

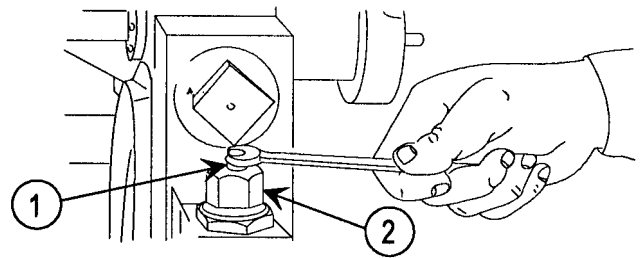

- 4 Clean recess in oil valve assembly (2) with wiping rag.

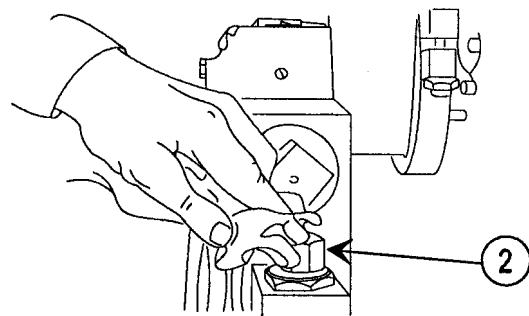

- 5 Install drain tool (3) in oil valve assembly (2) and drain oil reserves.
- 6 Remove drain tool (3).

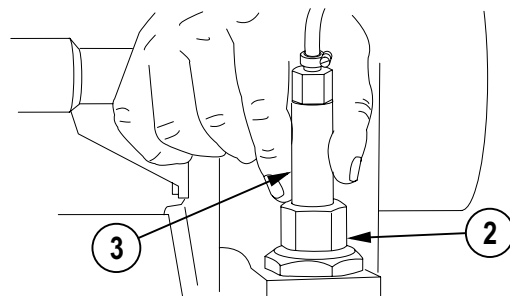

- 7 Remove purge plug (4) and gasket (5) from purge port on recuperator.

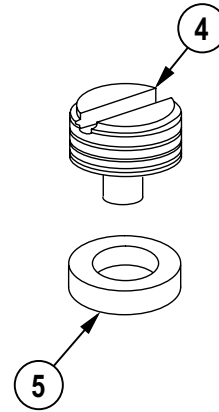

- 8 Install purge pipe assembly (6) in purge port on recuperator with valve (7) in closed position.

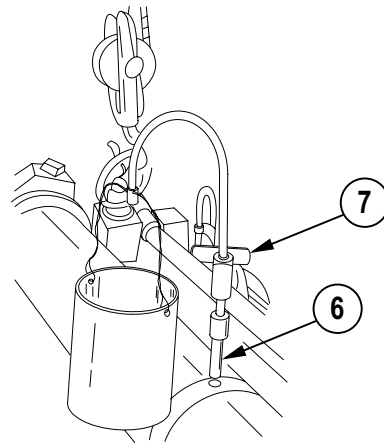

- 9 Remove purge plug (8) and gasket (9) from purge port (10) on replenisher cylinder.

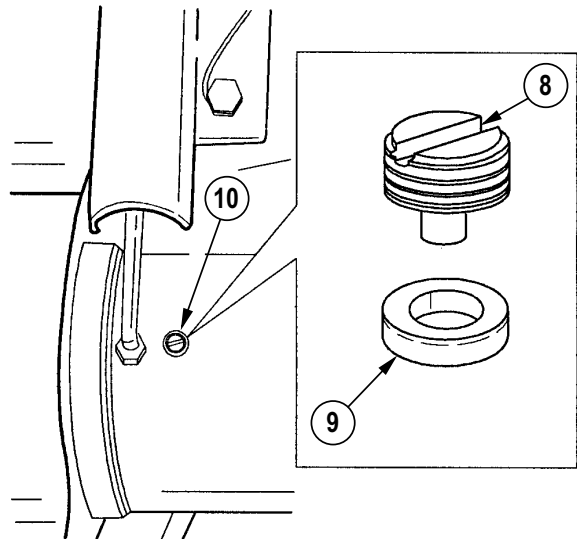

2-10. M45 RECOIL MECHANISM—MAINTENANCE INSTRUCTIONS (cont)

ALTERNATE METHOD—FILLING RECOIL MECHANISM WITH OIL AND PURGING OIL OF AIR (cont)

- 10 Install purge pipe assembly (11) in purge port (10) on replenisher cylinder with valve (12) in closed position.

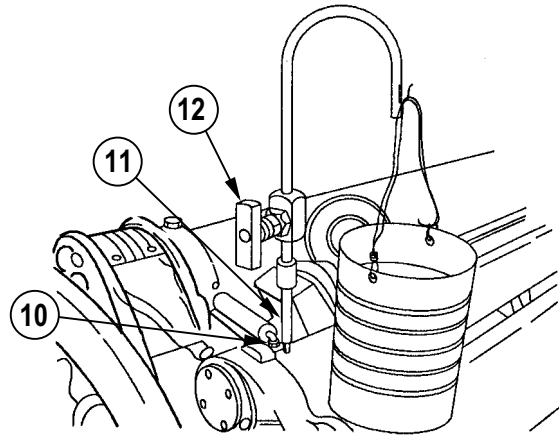

NOTE

Procedures are written for one recoil cylinder assembly, but apply to both.

- 11 Remove lock wire (13), bolt (14), lockwasher (15), and restraint key (16).

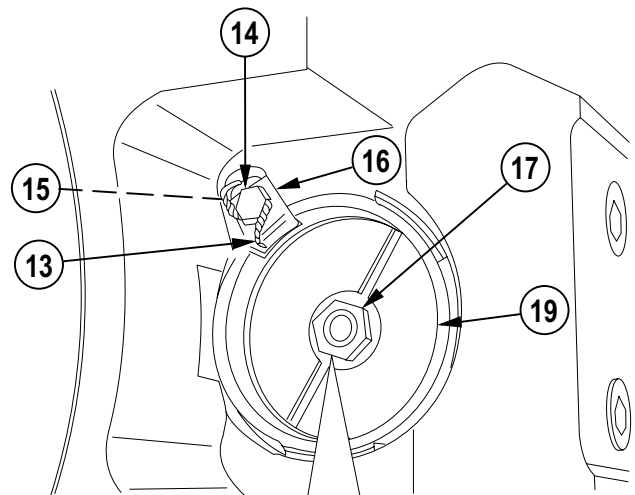

CAUTION

Thoroughly clean area before removing relief valve and adapter bushing. Failure to thoroughly clean area may result in premature system failure.

- 12 Remove relief valve (17). Using back removal tool (18) (Figure C-22A, appx C), remove adapter bushing (19).

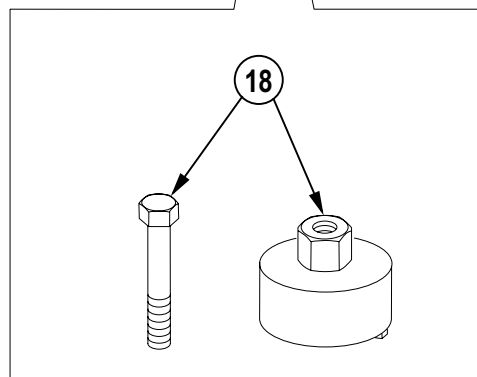

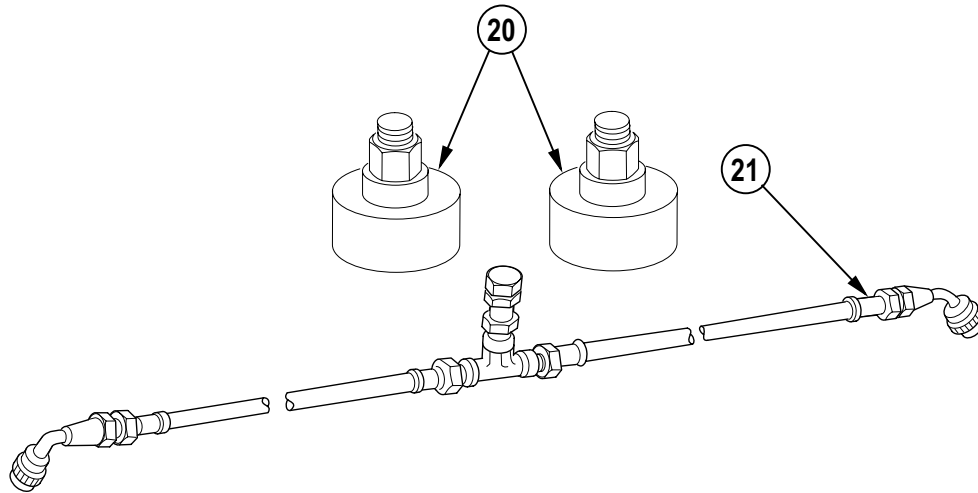

NOTE

Clean any dirt or debris from interior of recoil cylinder prior to installation of extension fixtures.

- 13 Install two recoil cylinder extension tools (20) (Figure C-22B, appx C) into recoil cylinder ends until snug. Do not overtighten.

- 14 Attach nitrogen hose assembly (12008918) (21) to two recoil cylinder extension tools (20).

- 15 Attach nitrogen charging kit (22) to nitrogen hose assembly (12008918) (21) and nitrogen bottle (23).

- 16 Set pressure regulator (24) to 500 psi.

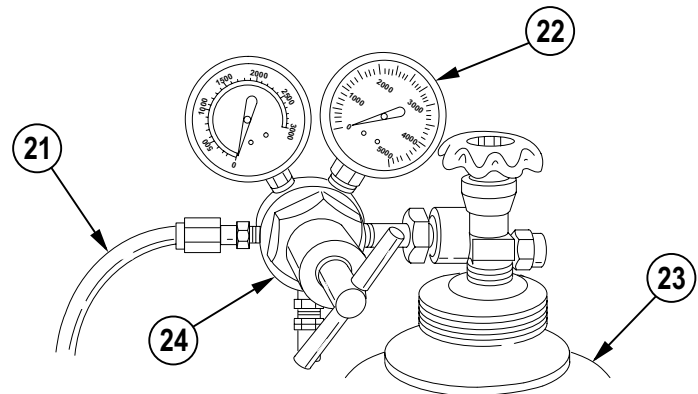

WARNING

M45 Recoil Mechanism will move out of battery once airline is opened. To avoid injury or damage, ensure all personnel and lines are clear.

NOTE

Ensure purge pipe assembly control valve is closed prior to opening airline to recoil cylinders.

Nitrogen may be heard leaking from recoil cylinder extension tools. This is normal.

Approximately 5 gallons of oil (OHT) will be discharged from M45 Recoil Mechanism. Drain into proper size container.

- 17 Open airline to two recoil extension tools (20).
- 18 Slowly install drain tool (3) to drain oil from recoil cylinders and allow cannon to come fully out of battery.
- 19 Close valve on nitrogen bottle (23) and drain pressure from recoil cylinders.
- 20 Remove two recoil extension tools (20) from end of recoil cylinders.

2-10. M45 RECOIL MECHANISM—MAINTENANCE INSTRUCTIONS (cont)

ALTERNATE METHOD—FILLING RECOIL MECHANISM WITH OIL AND PURGING OIL OF AIR (cont)

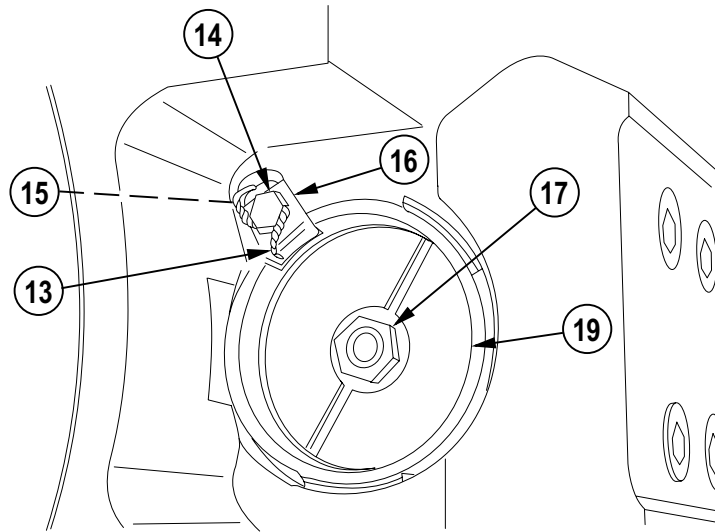

NOTE

Use rags to catch any oil leakage when removing tools. Wipe interior of recoil cylinders to remove any dirt or excess oil before installation of adapter bushings.

- 21 Install adapter bushing (19) and relief valve (17) until snug.
- 22 Install restraint key (16) into recoil cylinder and secure with lockwasher (15) and bolt (14).
- 23 Install lock wire (13) to secure bolt (14) to restraint key (16).

- 24 Remove drain tool (3) from oil valve assembly (2).

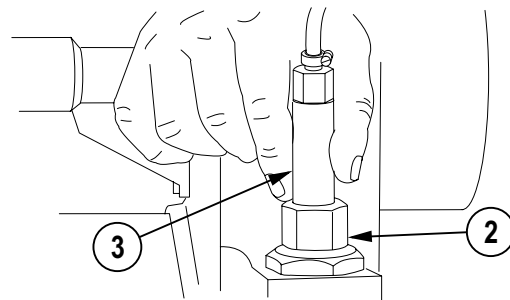

25 Install adapter (25) to oil valve assembly (2) and connect M3 oil pump line (26).

26 Pump recoil mechanism back into battery using M3 oil pump (27).

27 Open valves on purge pipe assemblies.

28 Pump oil into recoil mechanism with M3 oil pump (27) until oil flows from both purge pipe assemblies.

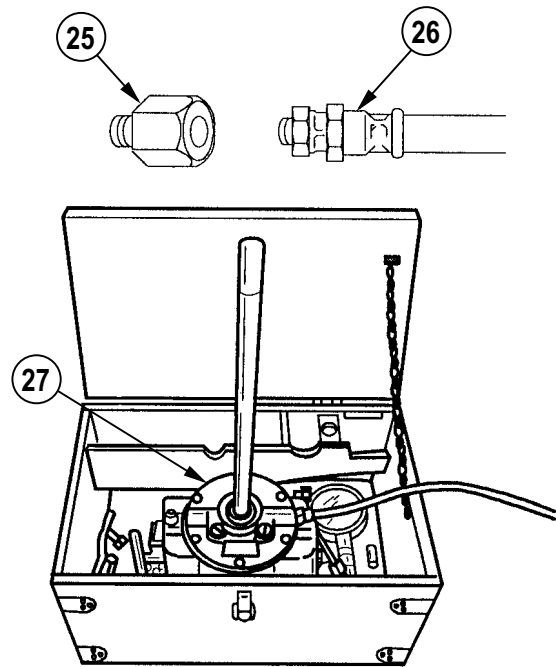

29 Close valves; establish three oil reserves.

30 Open purge plug on front oil yoke near filler valve until oil that is free of air flows from the opening; close purge plug.

31 Remove safety struts and fully depress cannon tube.

32 Drain oil from recoil mechanism by opening valve (7) on purge pipe assembly (6) installed in recuperator cylinder.

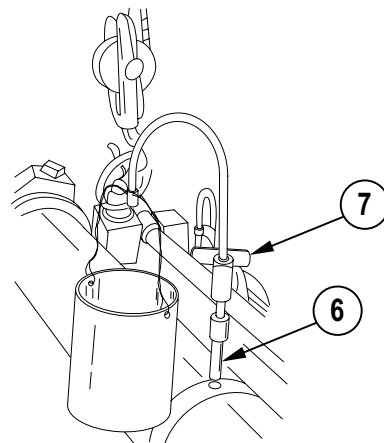

2-10. M45 RECOIL MECHANISM—MAINTENANCE INSTRUCTIONS (cont)

ALTERNATE METHOD—FILLING RECOIL MECHANISM WITH OIL AND PURGING OIL OF AIR (cont)

- 33 Disconnect rigid link (28) from recuperator by removing cotter pin (29) and sleeve pin (30).
- 34 Actuate lever (31) on end of recuperator several times, while pumping M3 oil pump, to remove any trapped air bubbles.
- 35 Reconnect rigid link (28) to recuperator, using sleeve pin (30) and cotter pin (29).

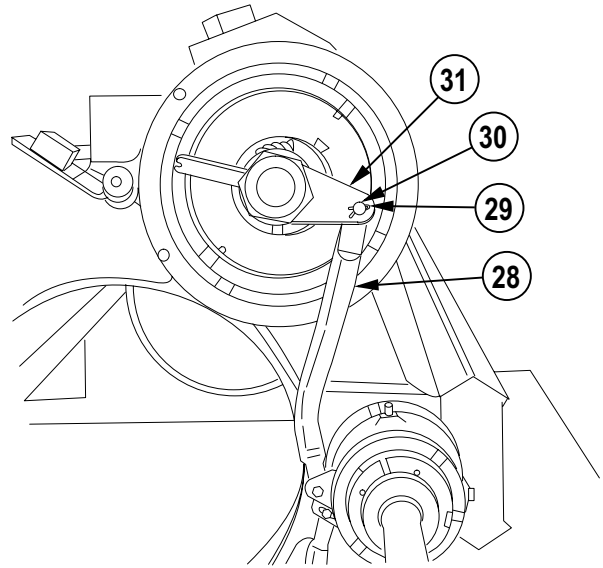

- 36 Close valve (7) on purge pipe assembly (6) installed in recuperator cylinder.

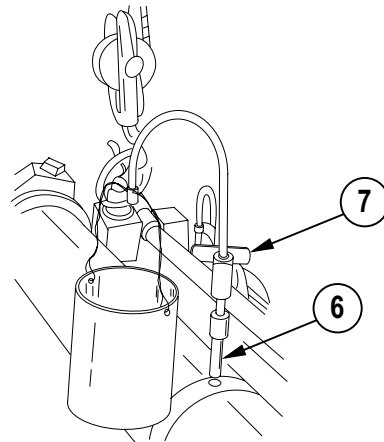

- 37 Open valve (12) on purge pipe assembly (11) installed in replenisher cylinder.
- 38 Pump M3 oil pump until clear oil flows from purge pipe assembly.
- 39 Close valve (12) on purge pipe assembly (11) installed in replenisher cylinder.

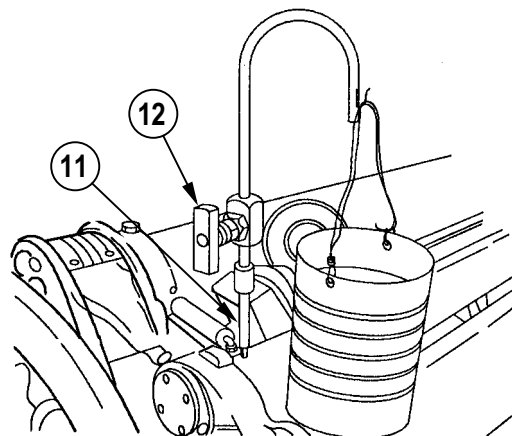

- 40 Pump M3 oil pump to establish four oil reserves.
- 41 Open valve (12) on purge pipe assembly (11) installed in replenisher cylinder.
- 42 Repeat steps 37 through 41 a minimum of three times or until no air bubbles are present in oil.

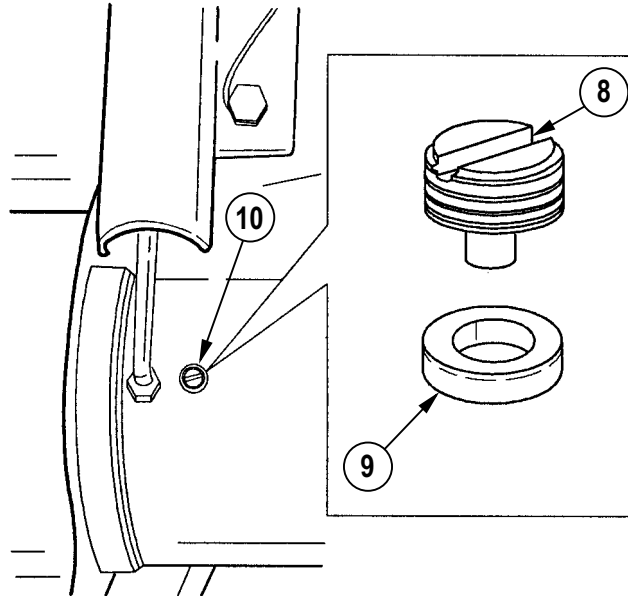

- 43 Remove purge pipe assembly from replenisher cylinder and install purge plug (8) and gasket (9) to purge port (10).
- 44 Pump M3 oil pump to establish four oil reserves.
- 45 Open valve (7) on purge pipe assembly (6) installed in recuperator cylinder.
- 46 Repeat steps 44 and 45 a minimum of three times or until no air bubbles are present in oil.

- 47 Remove purge pipe assembly from recuperator cylinder and install purge plug (4) and gasket (5).

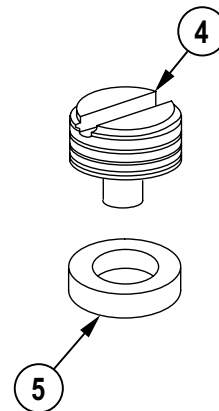

2-10. M45 RECOIL MECHANISM—MAINTENANCE INSTRUCTIONS (cont)

ALTERNATE METHOD—FILLING RECOIL MECHANISM WITH OIL AND PURGING OIL OF AIR (cont)

- 48 Pump M3 oil pump to establish four oil reserves.
- 49 Raise recoil mechanism to a level position.
- 50 Slightly open four purge plugs one at a time. Ensure that oil that is free of air flows from each port.

NOTE

If internal nitrogen leakage is suspected, continue with Leak Detection procedure.

- 51 Remove M3 oil pump from recoil mechanism.

- 52 Clean oil valve assembly (2) and install plug (1).

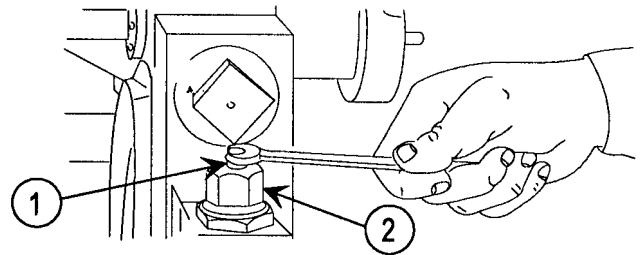

- 53 Check recoil mechanism for oil leaks.
- 54 Install ballistic shield and secure with lock wire.
- 55 Return howitzer to travel lock position.

LEAK DETECTION

NOTE

Recoil mechanism should be purged prior to leak detection. Excessive air in recoil mechanism could cause false indications of leakage.

- 1 Install drain tool (1) in oil valve assembly (2) and drain reserves.

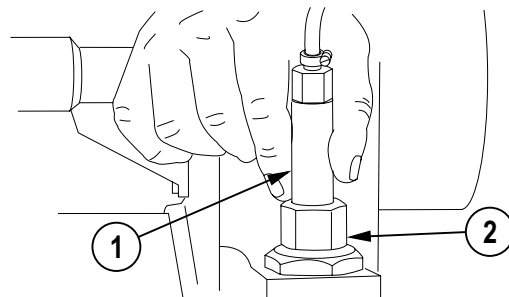

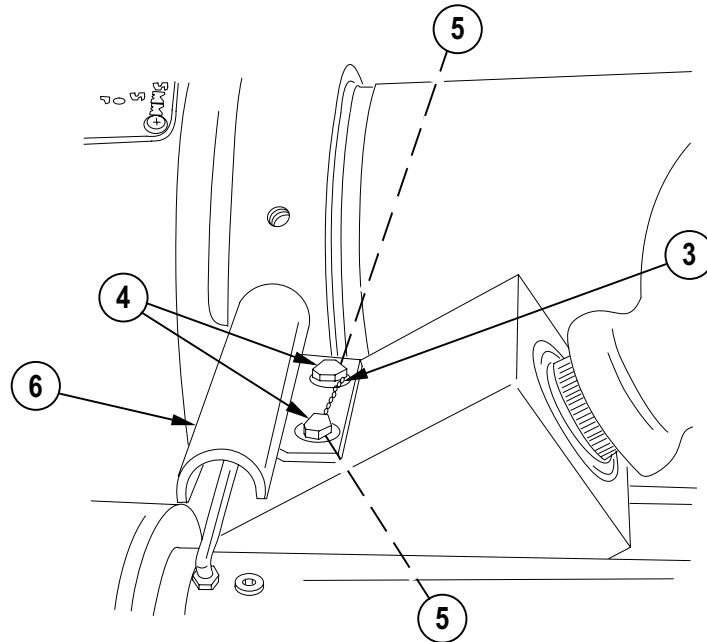

- 2 Remove lock wire (3), two bolts (4), two washers (5), and cover bracket (6).

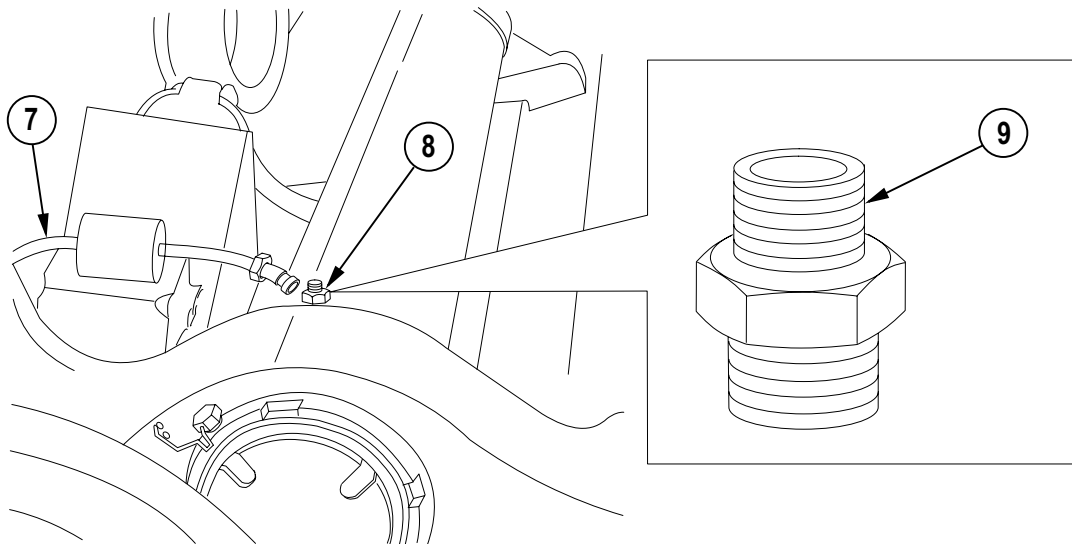

- 3 Disconnect crossover line (7) between recuperator and replenisher.
- 4 Remove adapter (8) from replenisher.
- 5 Install plug (9) (Figure C-22C, appx C) on replenisher cylinder to block OHT in the replenisher.
- 6 Install crossover line (7) on plug (9) to block the OHT from the recuperator.

2-10. M45 RECOIL MECHANISM—MAINTENANCE INSTRUCTIONS (cont)

LEAK DETECTION (cont)

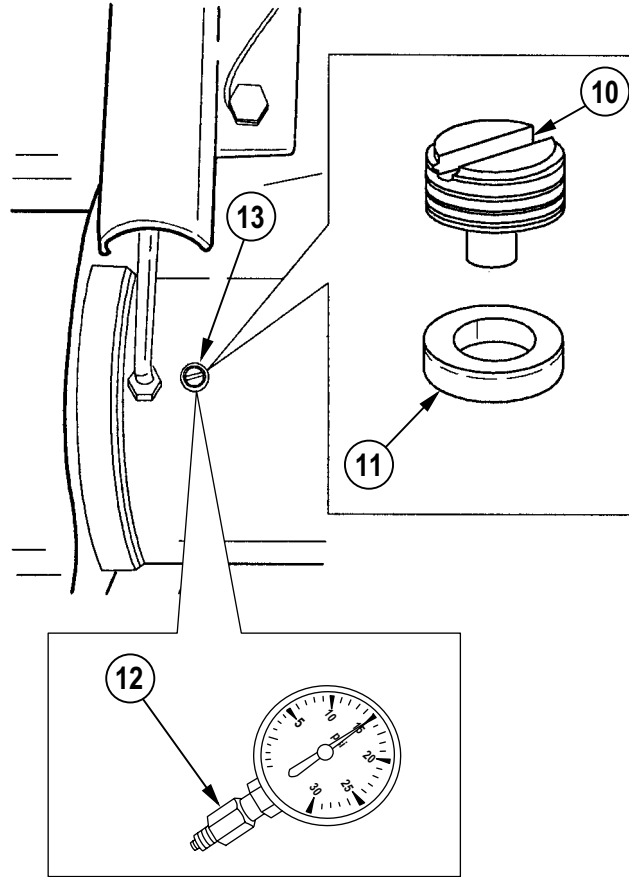

- 7 Remove purge plug (10) and gasket (11) from replenisher.
- 8 Install adapted gauge (12) (Figure C-22D, appx C) in purge port (13) on replenisher.

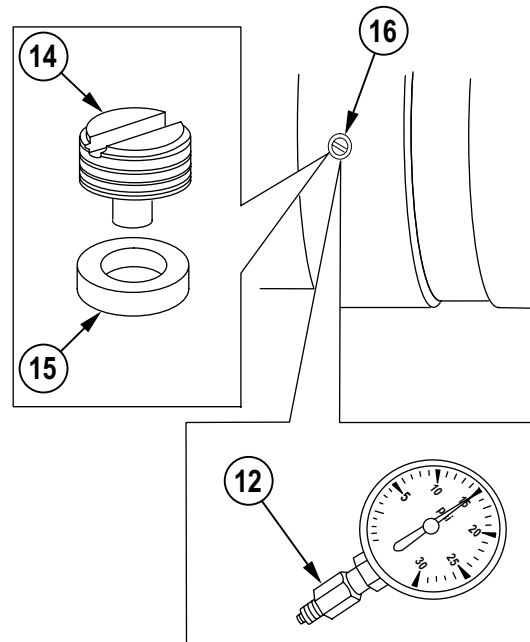

- 9 Remove purge plug (14) and gasket (15) from recuperator.
- 10 Install adapted gauge (12) in purge port (16) on recuperator.
- 11 Monitor gauges for pressure change for fifteen minutes.

NOTE

Slight changes in pressure may be due to changes in temperature or atmospheric conditions. Continually increasing pressure indicates a leaking cylinder.

- 12 If no pressure change is indicated, remove plug from crossover line and continue alternate purging procedure from Step 48.
- 13 If gauge shows pressure change, replace defective cylinder assembly. If replenisher cylinder needs to be replaced, refer to Paragraph 2-11. If recuperator cylinder assembly needs to be replaced, refer to Paragraph 2-14.
- 14 After replacing one or both cylinders, recharge nitrogen. Refer to Paragraph 2-10.
- 15 Initiate purging process.

2-10. M45 RECOIL MECHANISM—MAINTENANCE INSTRUCTIONS (cont)

DRAINING OIL RESERVES

WARNING

M199 cannon may be on weapon for this procedure. If it is, cannon tube must be at zero elevation to prevent recoil mechanism and M199 cannon from sliding out of battery in the event that all reserves are drained out of system.

- 1 Remove plug (1).
- 2 Clean recess in oil valve assembly (2) with wiping rag.
- 3 Insert liquid tool assembly (3) and recoil hose assembly (4) in recess in oil valve assembly (5), and hand-tighten.
 - a. Place free end of recoil hose assembly (4) in container (6).
 - b. Turn liquid tool assembly (3) to release oil reserves until oil stops flowing
 - c. Remove liquid tool assembly (3) and recoil hose assembly (4).
- 4 Clean recess in oil valve assembly (2) with wiping rag.
- 5 Install plug (1).

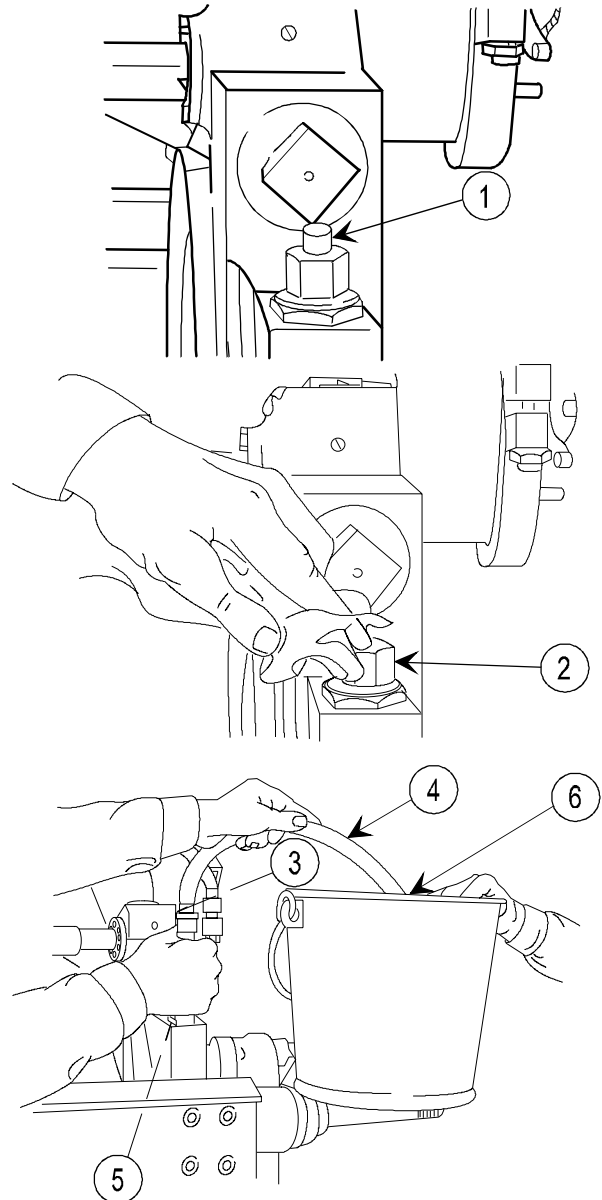

REMOVAL

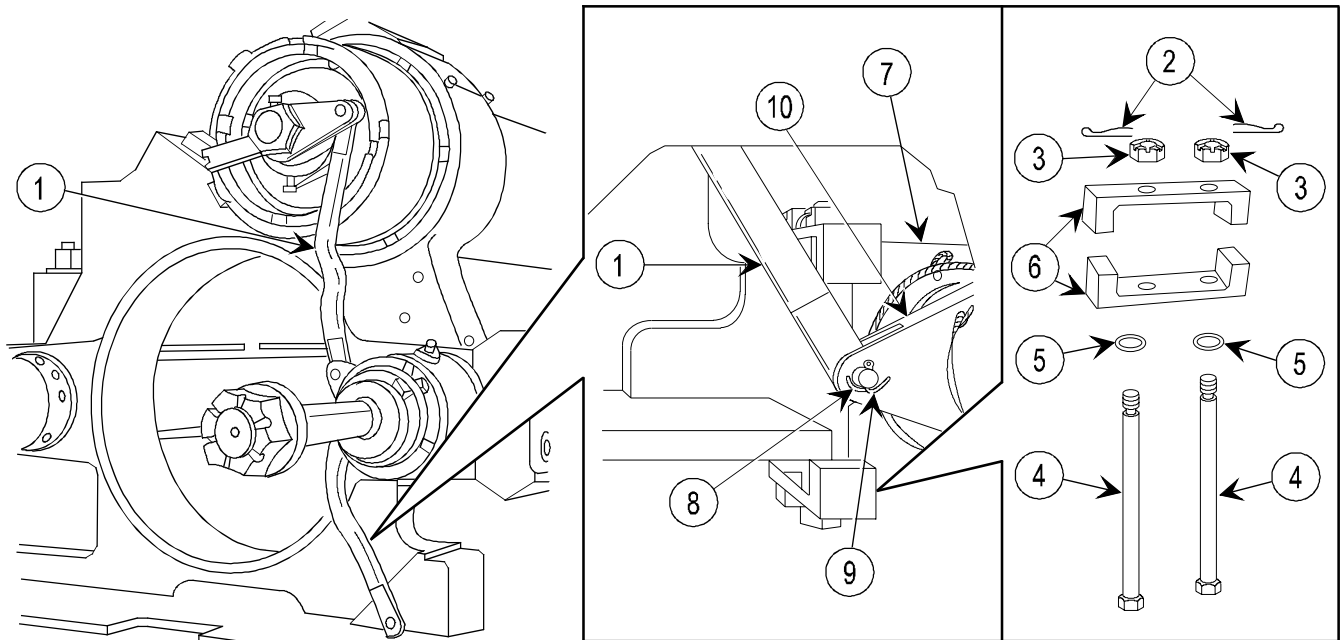

NOTE

Leave other end of rigid connecting link (1) attached to recoil mechanism.

1 Remove two cotter pins (2), two nuts (3), two bolts (4), two lockwashers (5), and two blocks (6) from nonrotating eye bracket (7).

2 Remove cotter pin (8) and straight pin (9), and disconnect rigid connecting link (1) from lever (10).

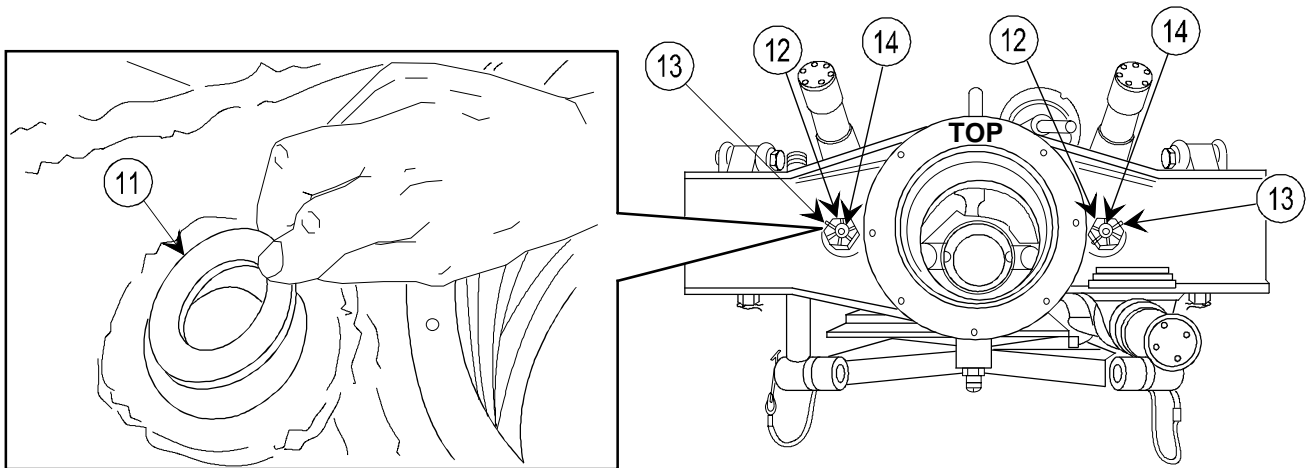

NOTE

If flat washers (11) come off when removing recoil mechanism, install and stake in place before installing nuts (12).

3 Remove two cotter pins (13) and two nuts (12) from ends of recoil rods (14).

2-10. M45 RECOIL MECHANISM—MAINTENANCE INSTRUCTIONS (cont)

REMOVAL (cont)

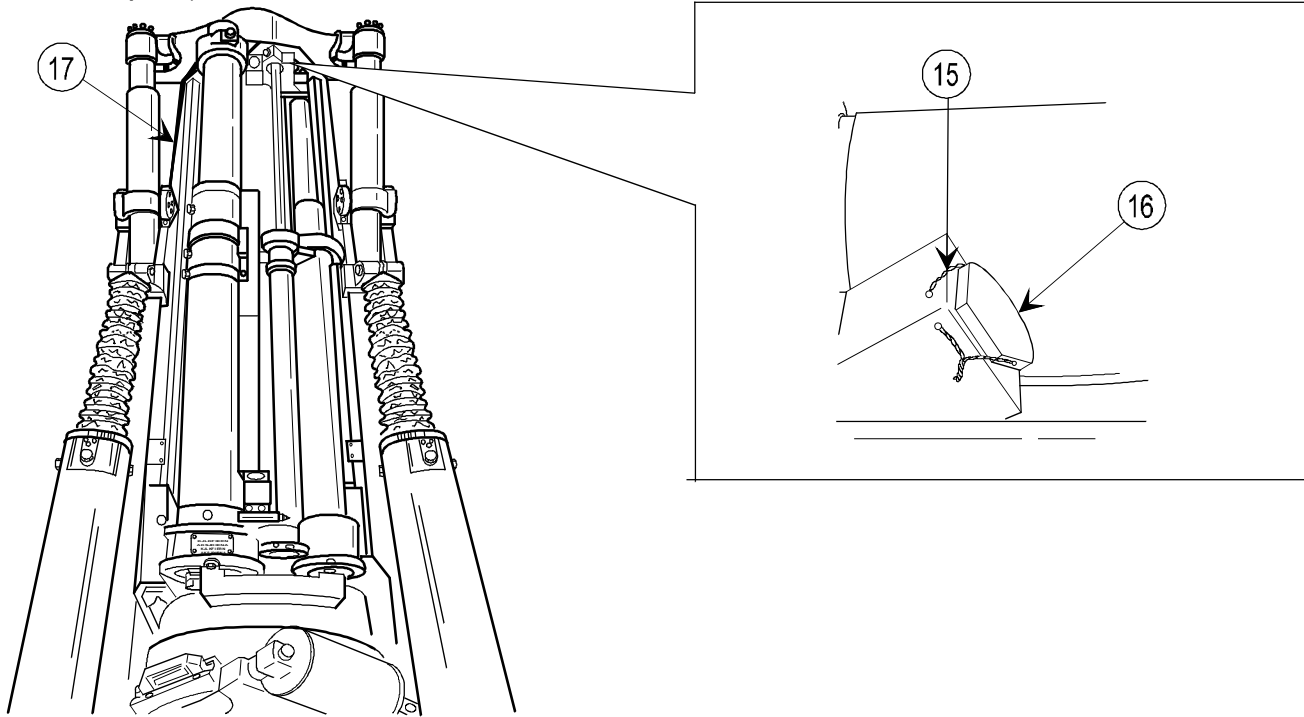

- 4 Remove lock wire (15) and two capscrews (16) from two lifting adapters in recoil mechanism (17).

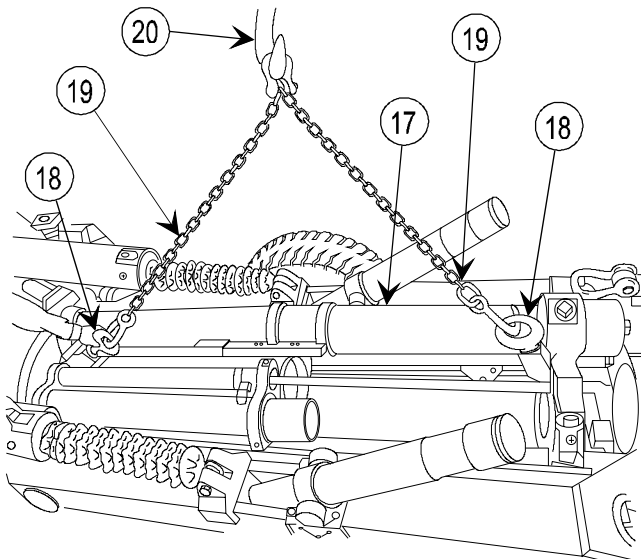

7 Deleted.

- 5 Install two eyebolts (18) to full thread depth.
- 6 Attach sling (19) to recoil mechanism eyebolts (18). Hook sling (19) to 3-ton hoist (20).

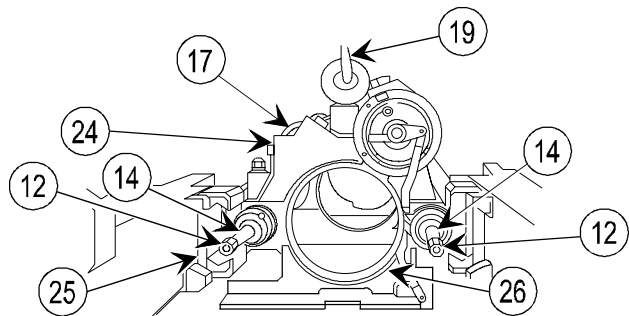
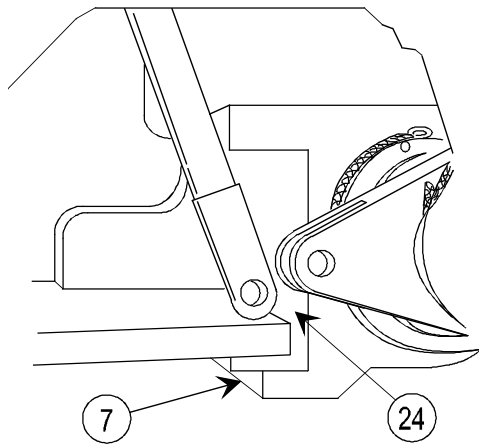

- 8 Raise recoil mechanism (17) and slide rearward approximately 12 in. (30 cm). Slide nonrotating eye bracket (7) from front yoke (24). To protect threads on recoil rods (14), screw nuts (12) on recoil rods (14).
- 9 Raise recoil mechanism (17) enough to slide rearward out of guide assemblies (25) of cradle assembly (26), and remove recoil mechanism (17).
- 10 Place on suitable blocking, and remove sling (19) and 3-ton hoist (not shown).

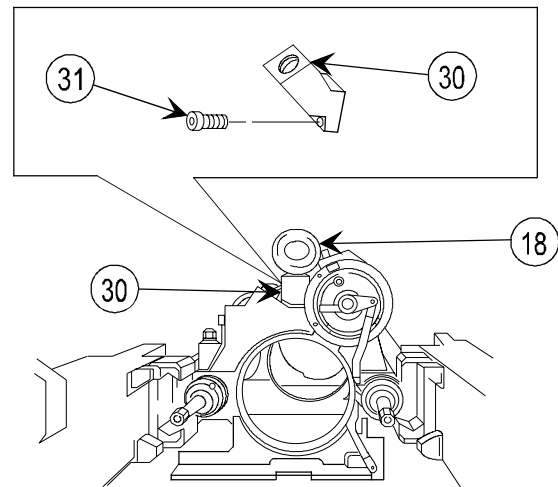
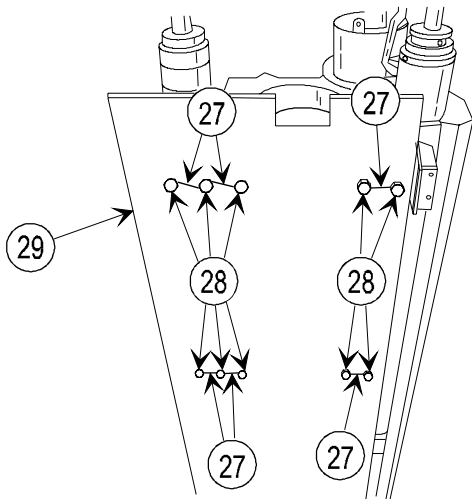

- 11 Ensure that lock wire (27) (item 35, appx B) securely holds ten bolts (28) to counterbalance weight (29) and front and middle yokes; replace lock wire if needed.
- 12 Replace ten bolts (28) if missing, and ensure they are not tightened down. (Clearance should be 1/8 to 1/4 turn loose.)
- 13 Install lock wire (27) (item 35, appx B).
- 14 Remove two eyebolts (18) from lifting adapters (30).
- 15 Remove four capscrews (31) and one lifting adapter (30).

INSPECTION/REPAIR

- 1 Check for broken, damaged, or missing parts.
- 2 Repair is by replacement of authorized parts (TM 9-1025-211-34P).

2-10. M45 RECOIL MECHANISM—MAINTENANCE INSTRUCTIONS (cont)

INSTALLATION

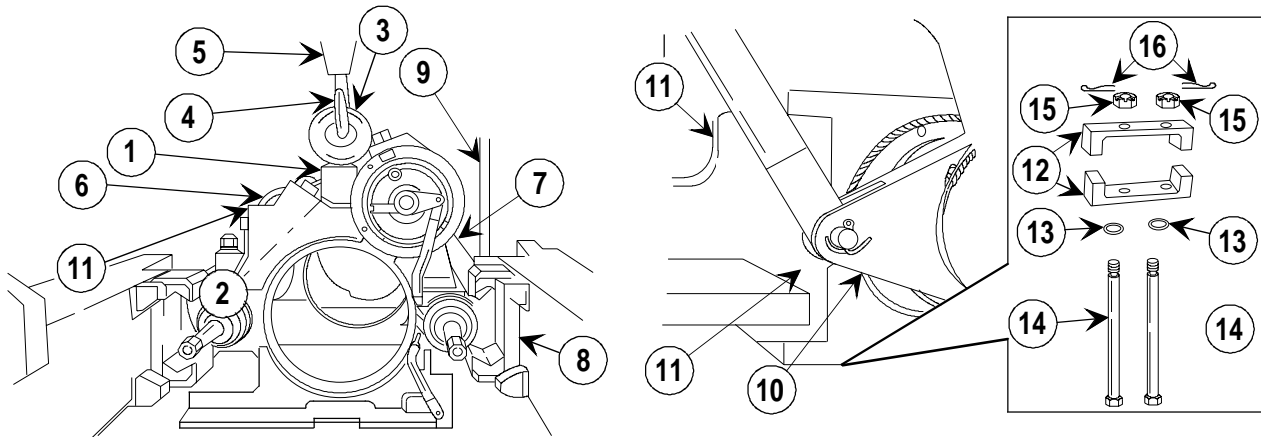

- 1 If removed, install one lifting adapter (1) and four capscrews (2).
- 2 Install two eyebolts (3) in lifting adapter (1).
- 3 Attach sling (4) and 3-ton hoist (5) to eyebolts (3).

NOTE

Before installing recoil mechanism (6), inspect rails (7) and remove all nicks and burrs with abrasive cloth. Apply light coat of WTR grease to rails (7) and guide assemblies (8).

- 4 Raise and aline rails (7) with guide assemblies (8) of leveled cradle assembly (9).
- 5 Slide recoil mechanism (6) forward approximately 3/4 of the way.
- 6 Slide nonrotating eye bracket (10) onto front yoke (11). Remove recoil rod nuts.
- 7 Install two blocks (12), two lockwashers (13), two bolts (14), two nuts (15), and two new cotter pins (16) to secure nonrotating eye bracket (10) to front yoke (11).

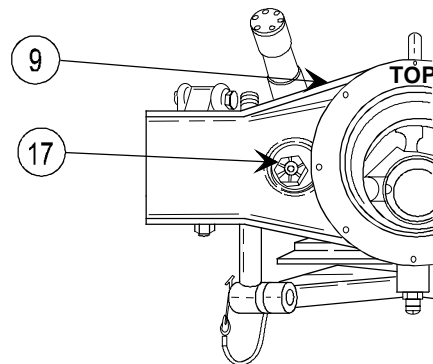
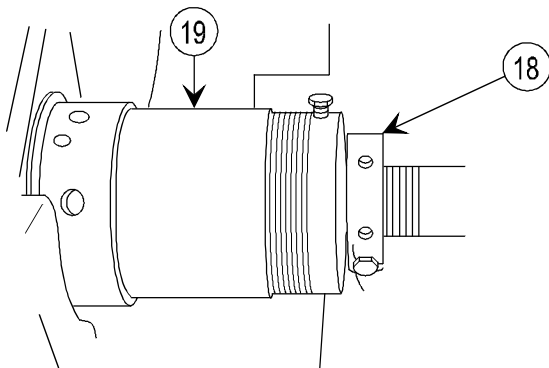

- 8 Install and stake two washers (17) to cradle assembly (9) if removed.

NOTE

If two nuts (18), one on each recoil cylinder (19), do not contact cradle assembly (9) when the M45 recoil mechanism is slid into position, adjustment (p 2-86) is necessary.

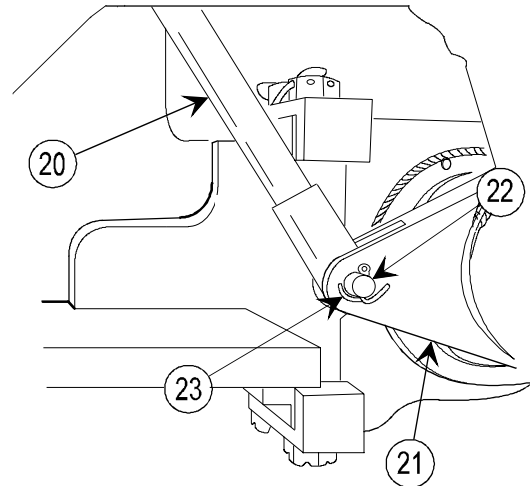
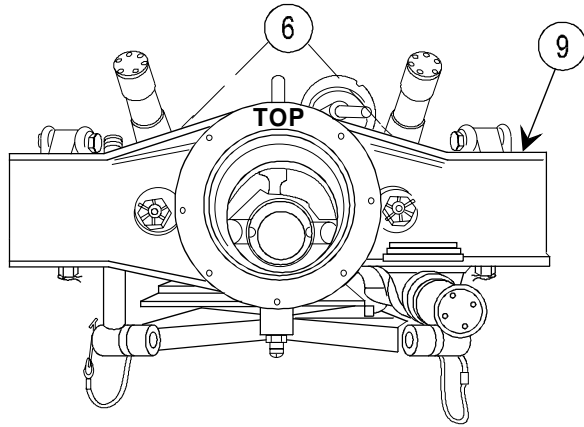

9 Slide recoil mechanism (6) against cradle assembly (9).

10 Connect rigid connecting link (20) to lever (21).

NOTE

Install straight pin (22) with head facing breech end.

11 Install straight pin (22) and new cotter pin (23).

12 Deleted.

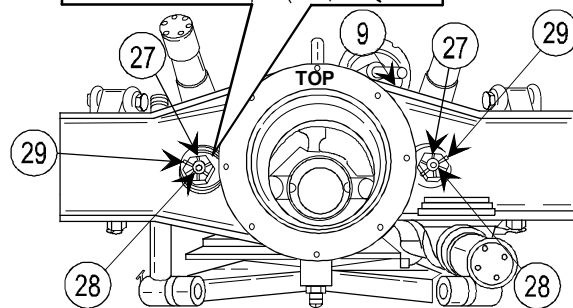
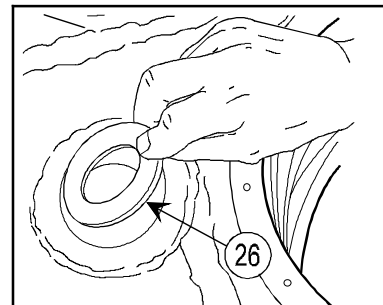

NOTE

Make sure the two flat washers (26) are in place before installing nuts (27).

13 Install two flat washers (26) and stake to cradle assembly (9). Screw two nuts (27) onto rods (28) until snug against cradle assembly (9), then back off to first cotter pin hole if necessary and insert new cotter pins (29).

2-10. M45 RECOIL MECHANISM—MAINTENANCE INSTRUCTIONS (cont)

INSTALLATION (cont)

- 14 Remove sling (4) and 3-ton hoist (5).
- 15 Remove two eyebolts (3).
- 16 Install two capscrews (30).
- 17 Install two lock wires (31) (item 34, appx B).

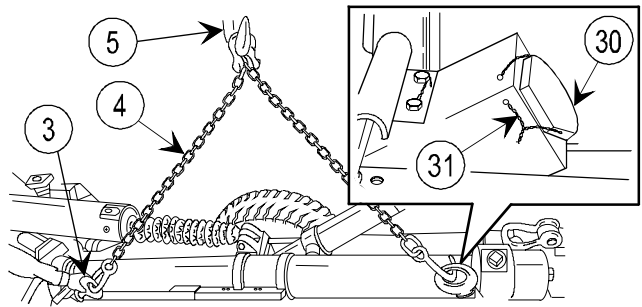

ADJUSTMENT

NOTE

The distance between nuts (1) and (2) on one of the recoil cylinder assemblies (3) must be at least 0.17 in. (4.32 mm) but not more than 0.21 in. (5.33 mm).

Nut (1) on the other recoil cylinder assembly is adjusted as necessary so that both nuts contact cradle assembly (4) when nuts (2) are in contact with the recoil cylinder (3).

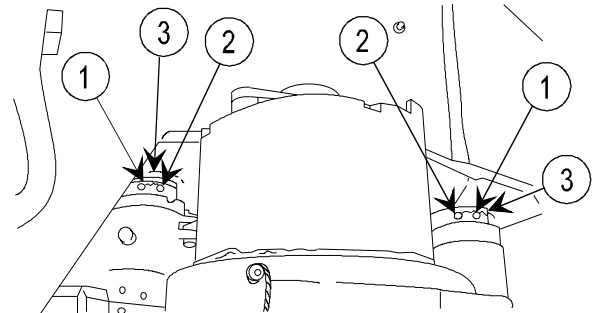

- 1 Remove lock wire (5) from setscrew (6) on recoil cylinder assembly (3) to be adjusted.
- 2 Remove setscrew (6).
- 3 Screw nut (1) back against nut (2).
- 4 Move recoil mechanism (7) forward until locked nut (1) on other recoil cylinder assembly contacts cradle assembly (4).

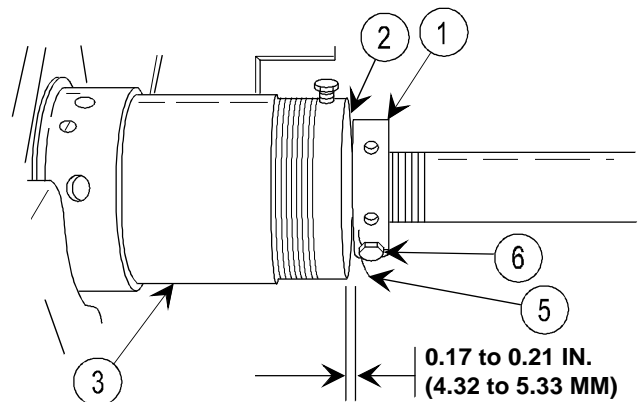

- 5 Remove two cotter pins (8) and two nuts (9) from two rods (10).
- 6 Adjust second nut (1) to contact cradle assembly (4).
- 7 Slide recoil mechanism (7) back approximately 12 in. (30 cm).

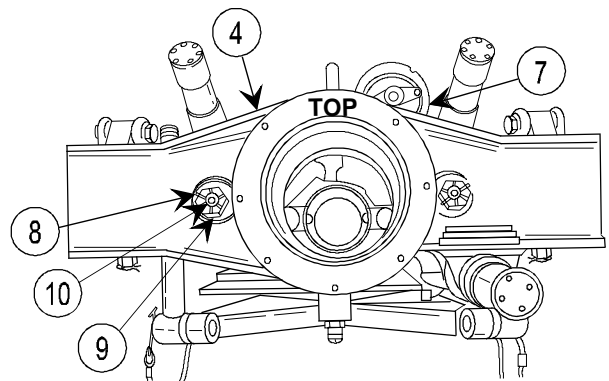

- 8 Drill 0.12 in. (3.10 mm) diameter hole 0.04 in. (1.00 mm) deep in rod (10) through one of the four threaded holes in nut (1).

- 9 Lock nut (1) in place by installing setscrew (6).
- 10 Install lock wire (5) (item 34, appx B) on setscrew (6).
- 11 Slide recoil mechanism (7) forward against cradle assembly (4).

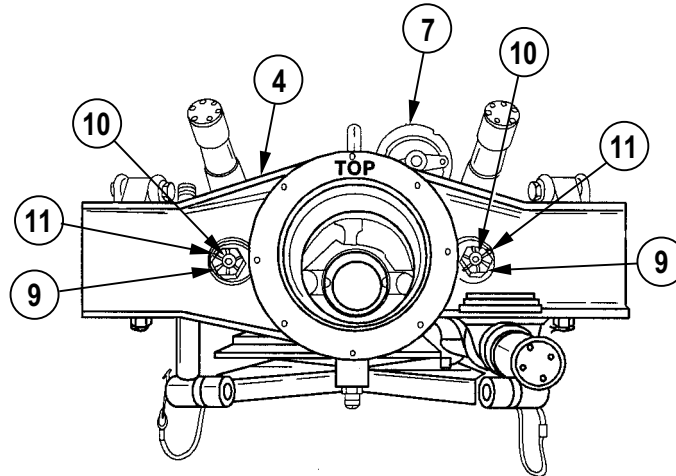

- 12 Screw two nuts (9) onto rods (10) until snug against cradle assembly (4), then back off to the first cotter pin hole if necessary, and insert new cotter pins (11).
- 13 Deleted.

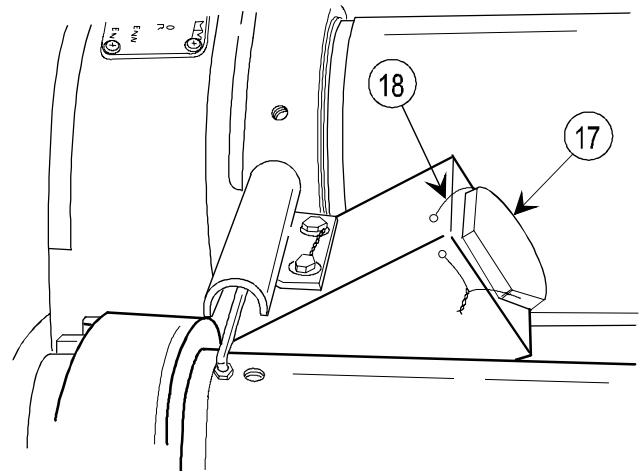
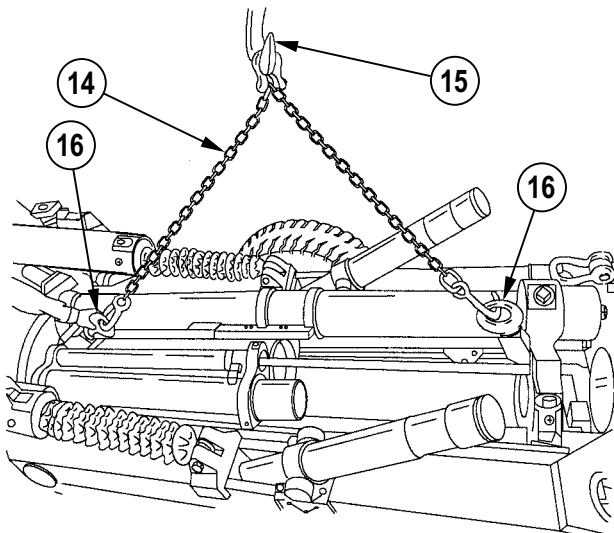

- 14 Remove sling (14) and 3-ton hoist (15).
- 15 Remove two eyebolts (16).
- 16 Install two cap screws (17).
- 17 Install two lock wires (18) (item 34, appx B).

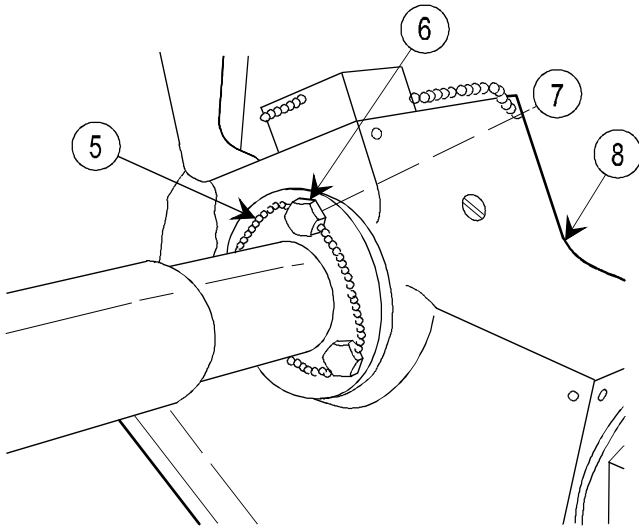

2 Remove lock wire (5), three cap screws (6), and three lockwashers (7) from rear of front yoke (8).

4 Using the M3 oil pump, add reserves (p 2-58) in four inch increments and leak check the location where the rod (11) comes out of the replenisher cylinder (12). With rod (11) fully extended (26 inches), inspect for scratches and paint over spray. If scratches are visible and nitrogen leaks are discovered in the area of scratches, replace replenisher cylinder (12) (p 2-88.6). If paint over spray is visible, remove using paint remover and crocus cloth. If rod (11) is clean and unscratched but still leaks nitrogen where rod comes out of replenisher cylinder (12), proceed to step 5.

5 Drain oil reserves (p 2-58).

6 Remove nitrogen from cylinder (p 2-58).

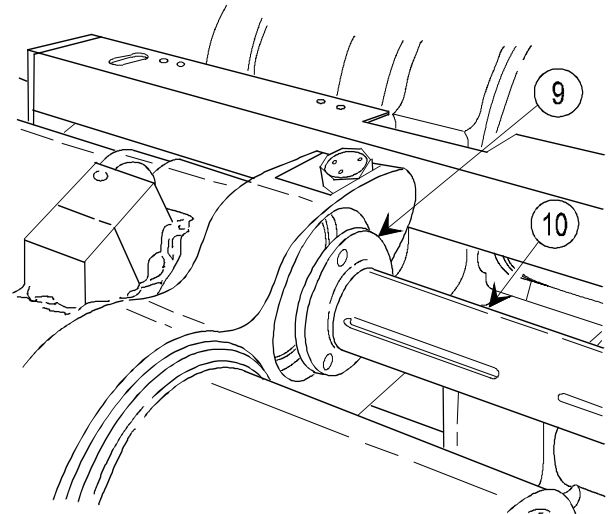

3 Remove sleeve bushing (9) and oil reserve indicator (10) by sliding off.

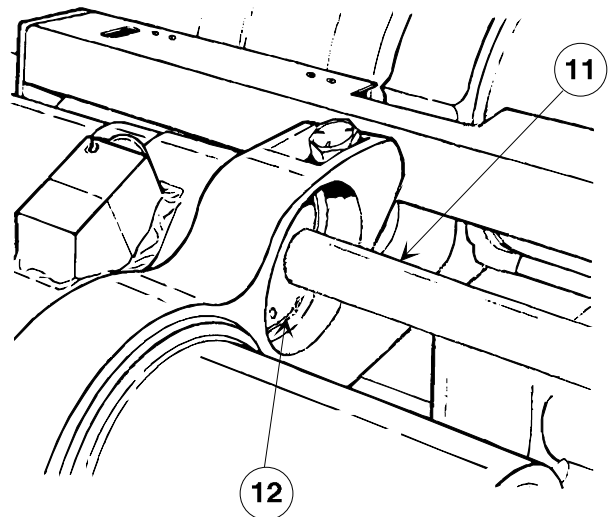

WARNING
Do not attempt to remove bolts or cap prior to draining recoil nitrogen pressure.

7 Remove lock wire (13), two bolts (14), and cap (15).

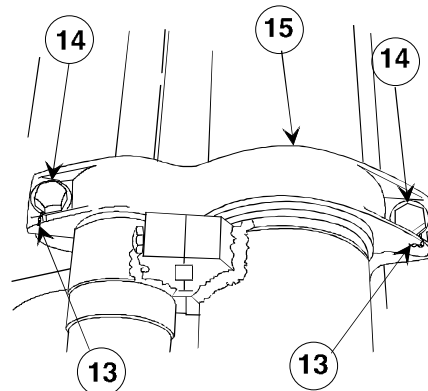

2-10.1. REPLENISHER CYLINDER ASSEMBLY—REPAIR INSTRUCTIONS (cont)

DISASSEMBLY (cont)

- 8 Scribe line of face of end assembly (13) and replenisher cylinder (12).
- 9 Remove setscrew (14).
- 10 Using a spanner wrench, unscrew end assembly (13) from replenisher assembly (12).

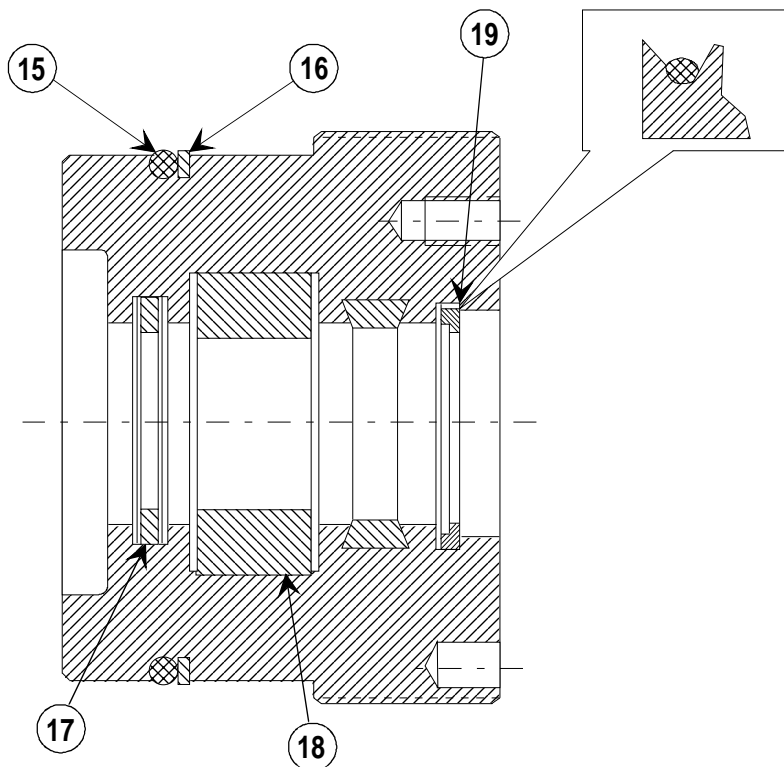
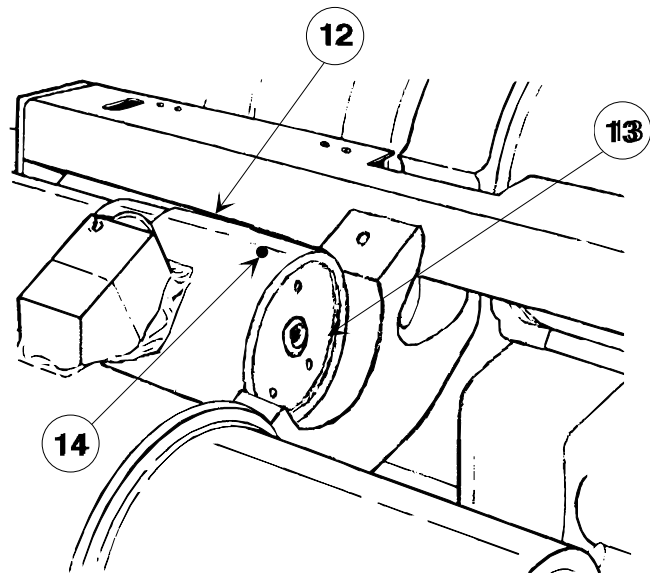

- 11 Remove preformed packing (15), packing retainer (16), plain encased seal (17), preformed mechanical felt (18), and plain seal (19).

INSPECTION/REPAIR

- 1 Check for broken, missing, or damaged parts.
- 2 Repair is by replacement of authorized parts (TM 9-1025-211-34P).
- 3 Soak preformed mechanical felt in OHT; lubricate preformed packing and plain encased seal with OHT prior to installation.

REASSEMBLY

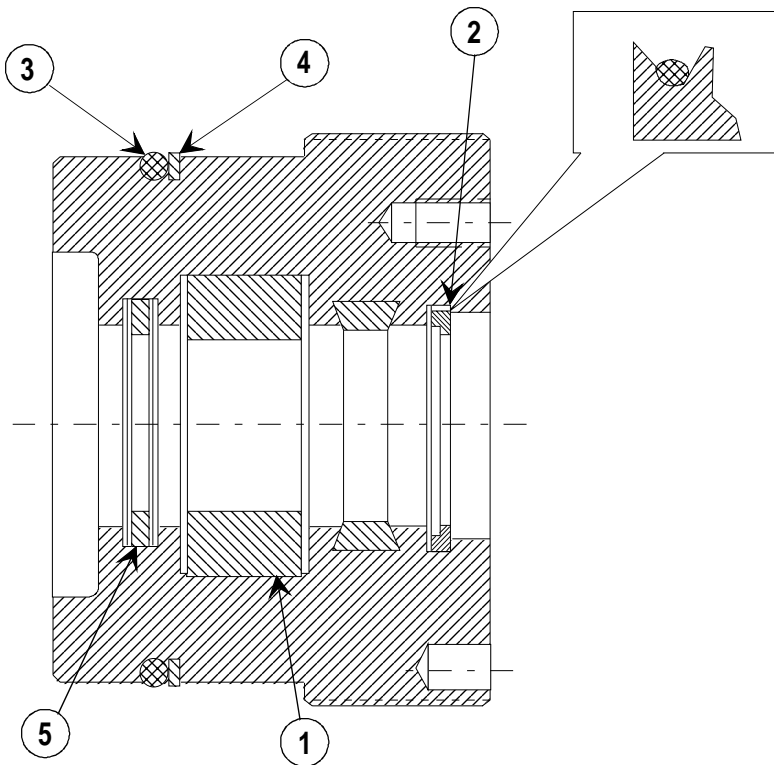

- 1 Install preformed mechanical felt (1), plain seal (2), preformed packing (3), and packing retainer (4).
- 2 Install plain encased seal (5) by installing the seal first, followed by the retainers on both sides.

2-10.1. REPLENISHER CYLINDER ASSEMBLY—REPAIR INSTRUCTIONS (cont)

REASSEMBLY (cont)

- 3 Install end assembly (6) into replenisher cylinder (7). The end assembly scribed line shall be aligned with scribed line on the replenisher cylinder when the two faces are flush.
- 4 Install setscrew (8) until bottomed out into the indent machined into the end assembly (6).

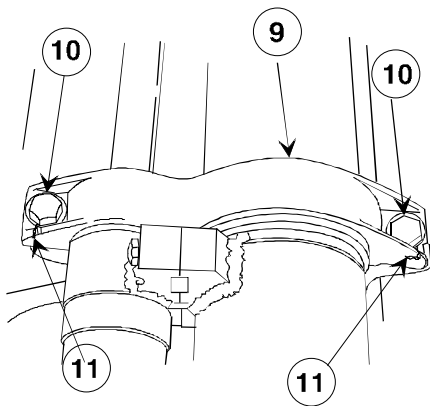
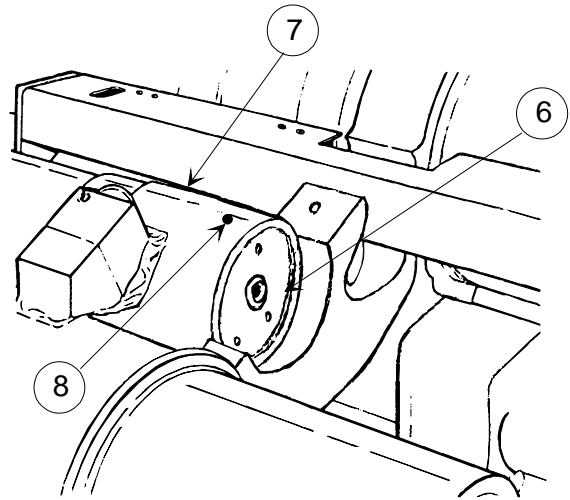

- 5 Install cap (9); install and tighten two bolts (10). Install lock wire (11).
- 6 Charge recoil mechanism with nitrogen (p 2-58).
- 7 Return to Disassembly, step 4, and check for nitrogen leaks. If leaks are detected, replace replenisher cylinder assembly (para 2-11). If no leaks are discovered, proceed to step 8.

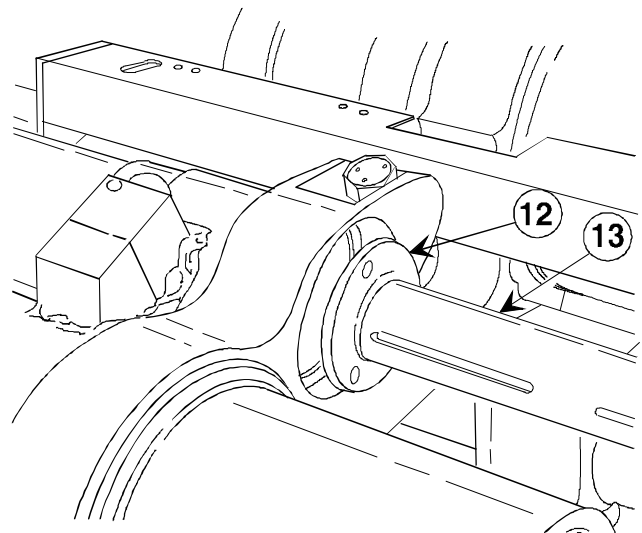

- 8 Drain oil reserves (p 2-58).
- 9 Install sleeve bushing (12) and oil reserve indicator (13) so that scale on oil reserve indicator (13) is visible from right side of weapon. Make sure slot on sleeve bushing (12) lines up with slot in oil reserve indicator (13).

10 Install three lockwashers (14) and capscrews (15), and tighten in rear of front yoke (16).

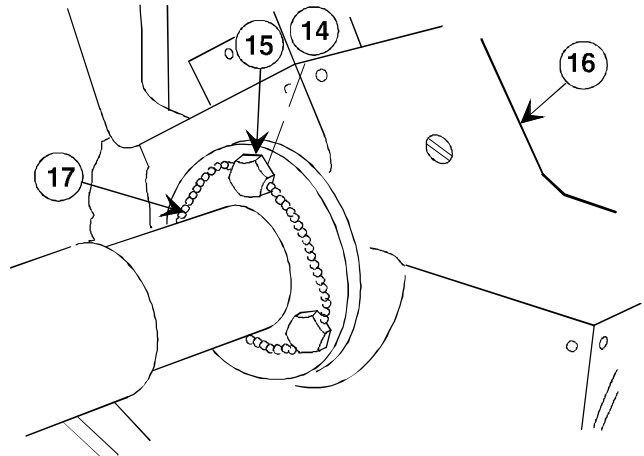

11 Install lock wire (17) (item 34, appx B).

12 Install three lockwashers (18) and capscrews (19), and tighten in front of middle yoke (20).

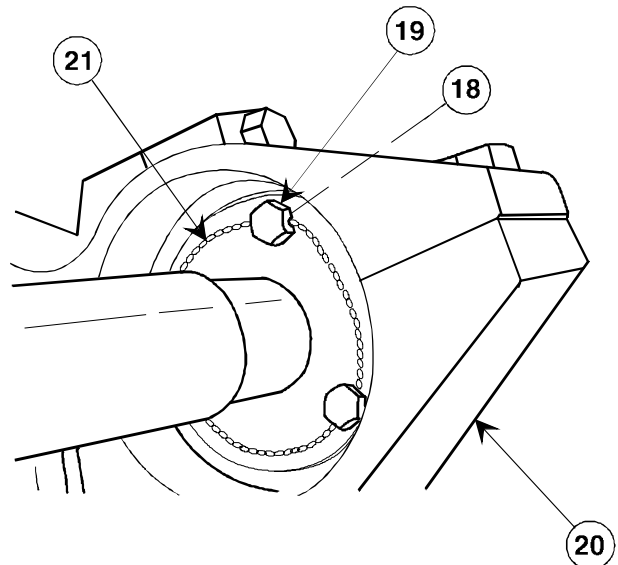

13 Install lock wire (21) (item 34, appx B).

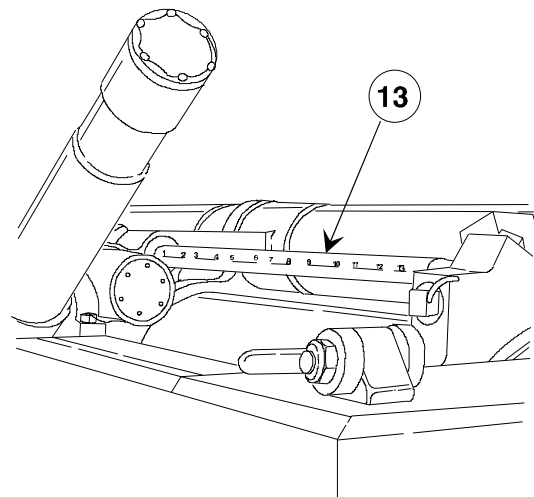
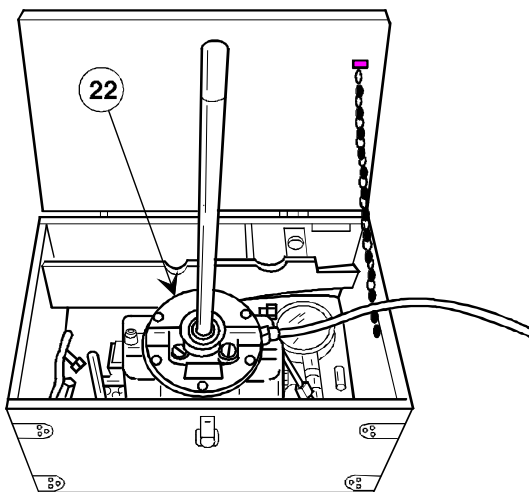

14 Operate M3 oil pump (22) until three reserves are indicated on oil reserve indicator (13).

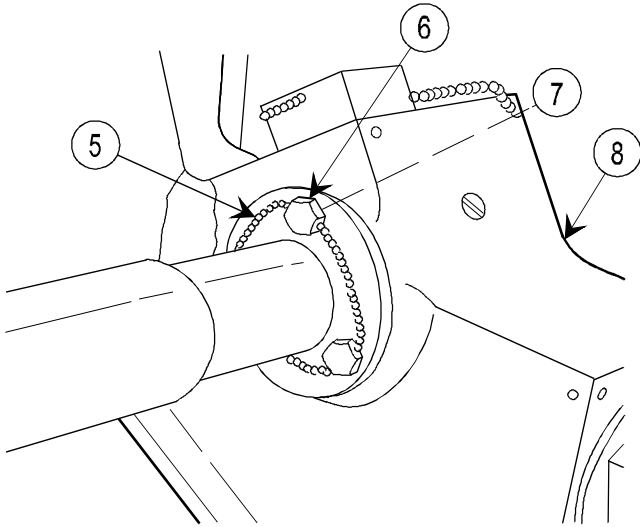

- 2 Remove lock wire (5), three capscrews (6), and three lockwashers (7) from rear of front yoke (8).

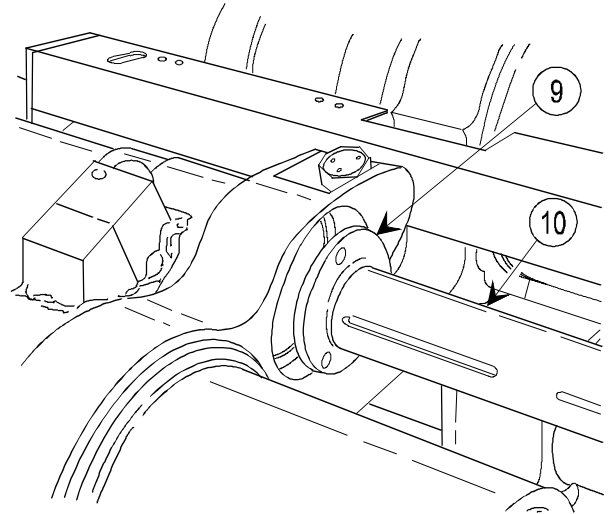

- 3 Remove sleeve bushing (9) and oil reserve indicator (10) by sliding off.

NOTE

If only sleeve bushing (9) and/or oil reserve indicator (10) are to be replaced, steps 4 thru 15 need not be performed.

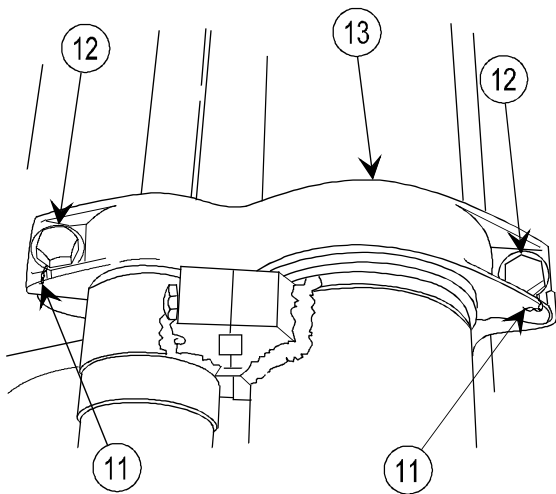

- 4 Remove lock wire (11) and two bolts (12) from cap (13).

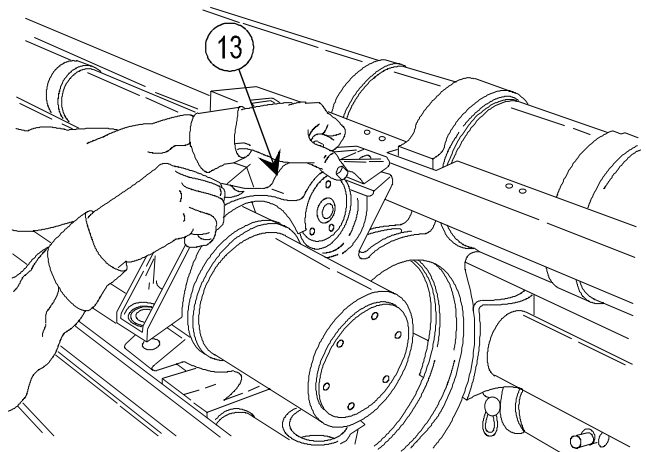

- 5 Remove cap (13).

2-11. REPLENISHER CYLINDER ASSEMBLY—MAINTENANCE INSTRUCTIONS (cont)

REMOVAL (cont)

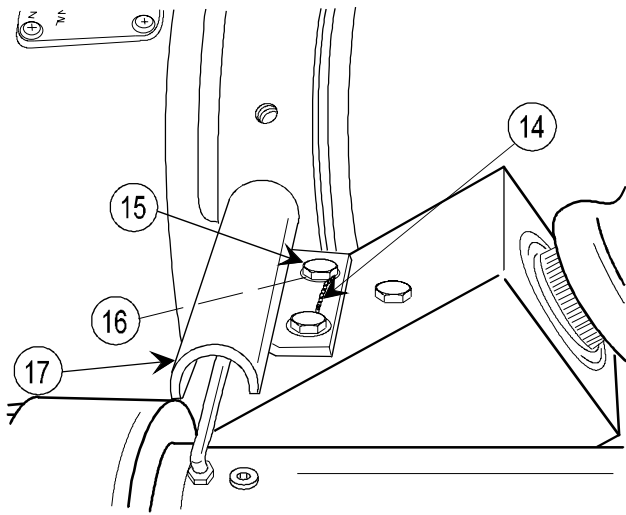

- 6 Remove lock wire (14), two capscrews (15), two lockwashers (16), and retaining strap (17).

NOTE

Tube (18) and bushing (19) are removed for replacement only.

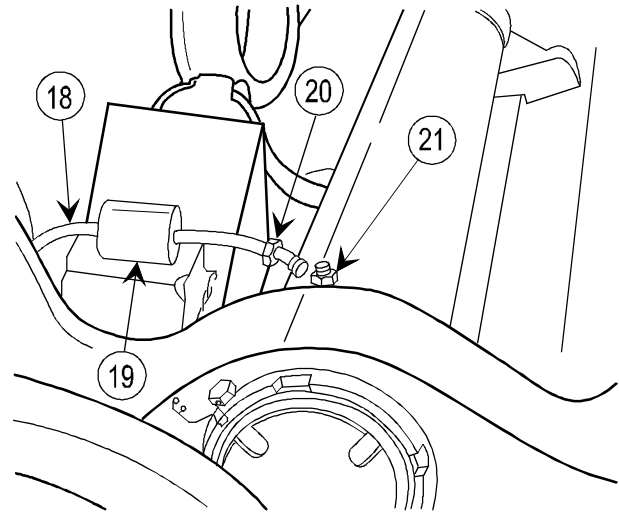

- 7 Unscrew two nuts (20) from adapter (21) at each end of tube (18), and remove tube (18) and bushing (19).

- 8 Remove two adapters (21).

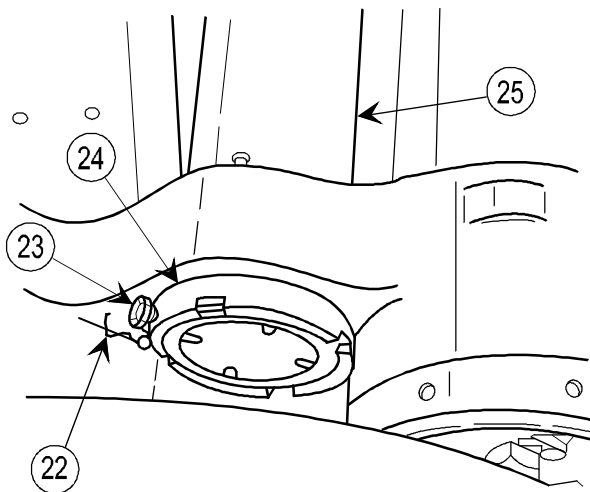

- 9 Remove lock wire (22) and setscrew (23) from nut (24) at rear of replenisher cylinder assembly (25).

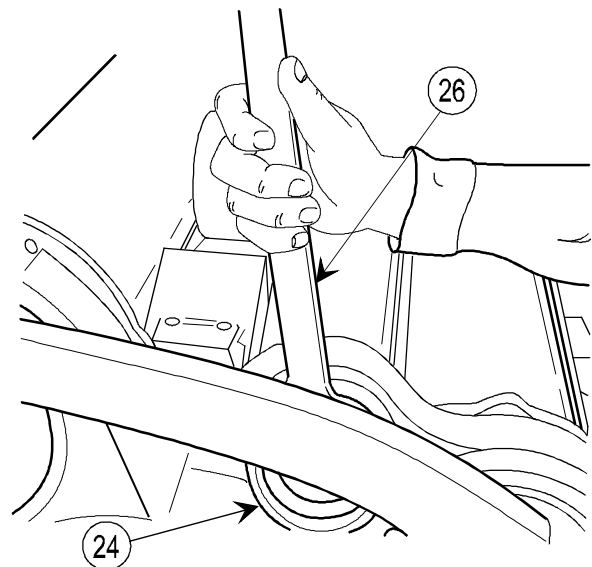

- 10 Unscrew nut (24) and remove, using spanner wrench (26).

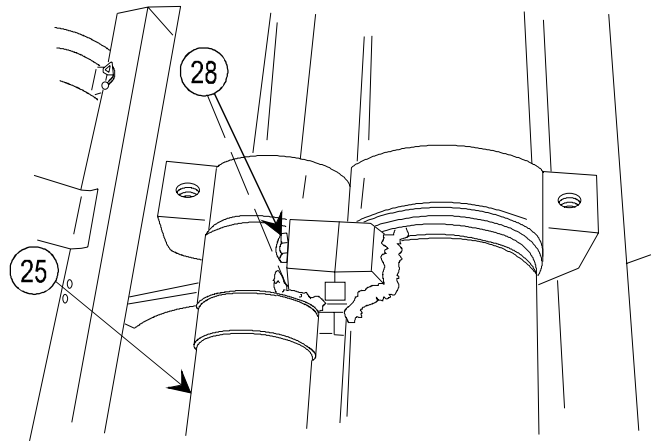
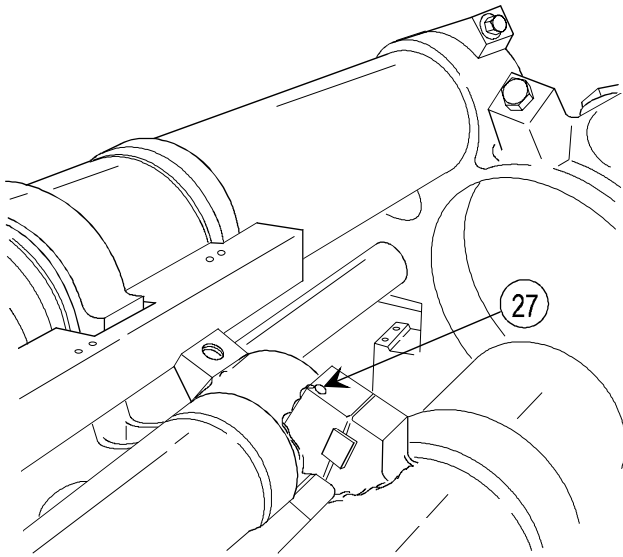

- 11 Remove lock wire (27) and two bolts (28) from front of replenisher cylinder assembly (25).

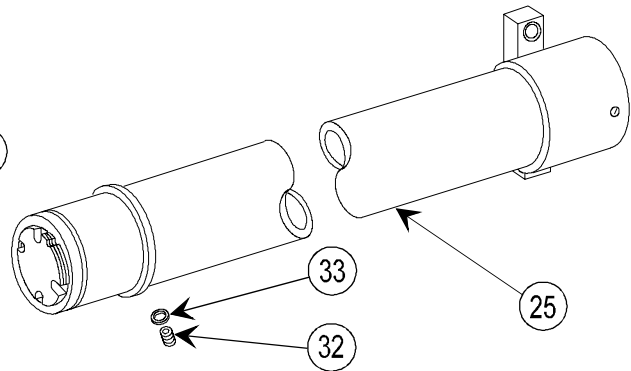
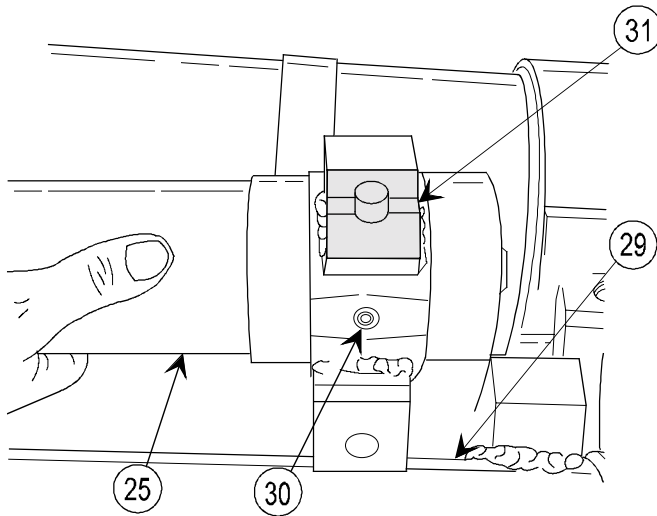

- 12 Remove replenisher cylinder assembly (25) from air cylinder assembly (29).
- 13 Remove preformed packing (30) from replenisher cylinder assembly (25).
- 14 Remove alining key (31) from replenisher cylinder assembly (25).
- 15 Remove setscrew (32) and gasket (33) from replenisher cylinder assembly (25).

INSPECTION/REPAIR

- 1 Check for broken, missing, or damaged parts.
- 2 Repair is by replacement of authorized parts (TM 9-1025-211-34P).
- 3 Replace replenisher cylinder assembly if oil leaks from plug or nitrogen pressure leaks from end assembly.

2-11. REPLENISHER CYLINDER ASSEMBLY—MAINTENANCE INSTRUCTIONS (cont)

INSTALLATION

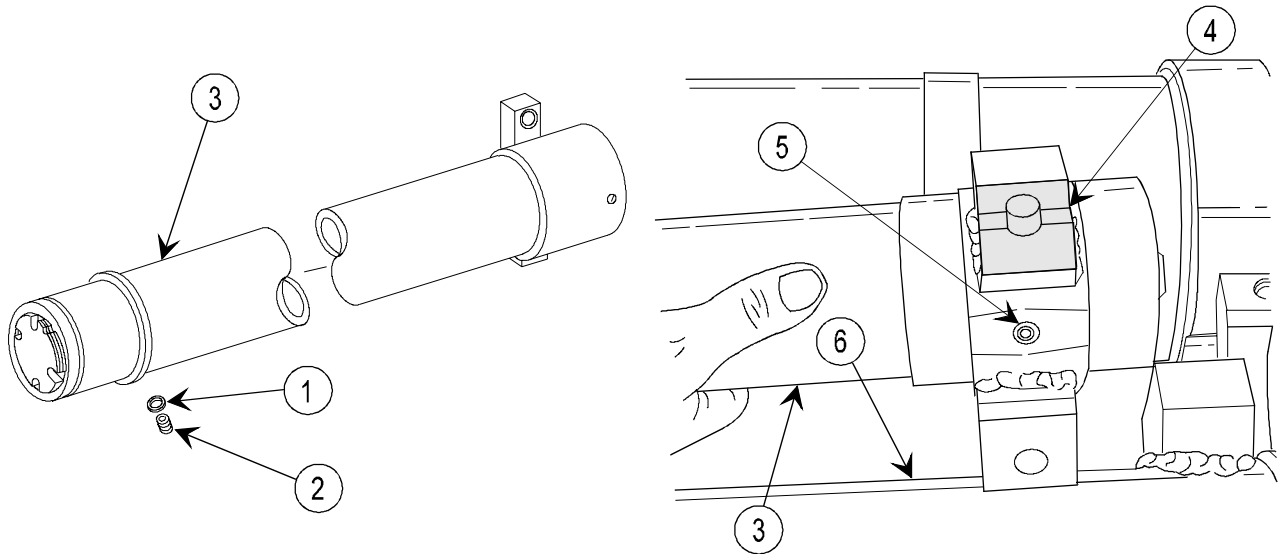

- 1 Install new gasket (1) and setscrew (2) on replenisher cylinder assembly (3).
- 2 Install alining key (4) on replenisher cylinder assembly (3).
- 3 Install new preformed packing (5) using WTR grease to hold it onto replenisher cylinder assembly (3).
- 4 Position replenisher cylinder assembly (3) on air cylinder assembly (6).

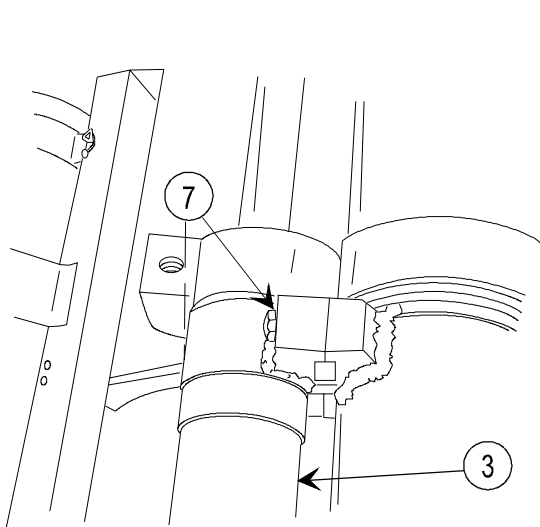

- 5 Install two bolts (7) fingertight on front of replenisher cylinder assembly (3).

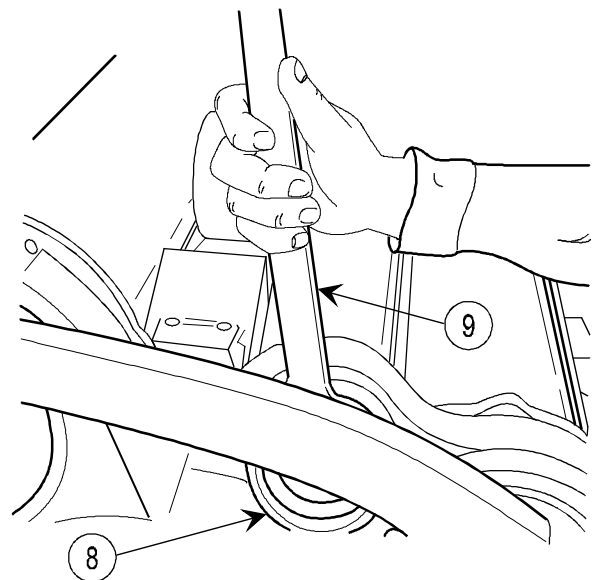

- 6 Install nut (8) and tighten securely, using spanner wrench (9).

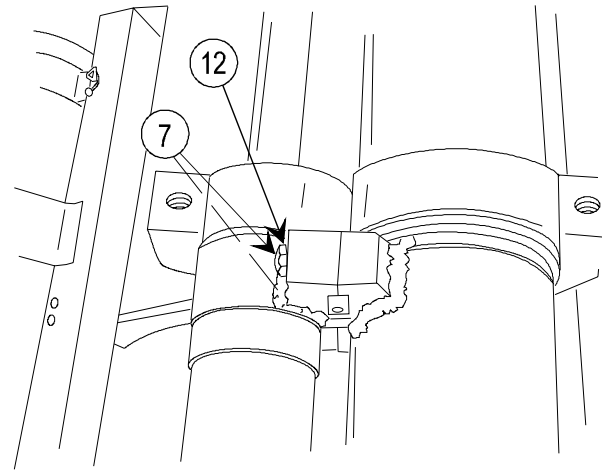
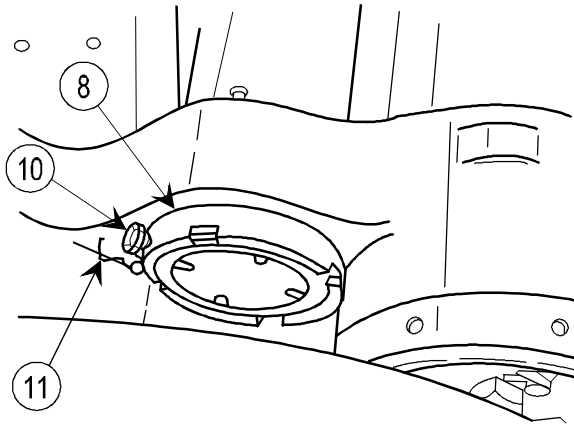

NOTE

If replenisher cylinder assembly was replaced, drill pilot hole 0.18 in. (4.57 mm) wide and 0.04 in. (1.01 mm) deep to accept point of setscrew (10).

- 7 Install setscrew (10) in nut (8) and tighten.
- 8 Install lock wire (11) (item 34, appx B).

- 9 Torque two bolts (7) 80 to 100 ft-lb (109 to 135 N-m).
- 10 Install lock wire (12) (item 35, appx B).

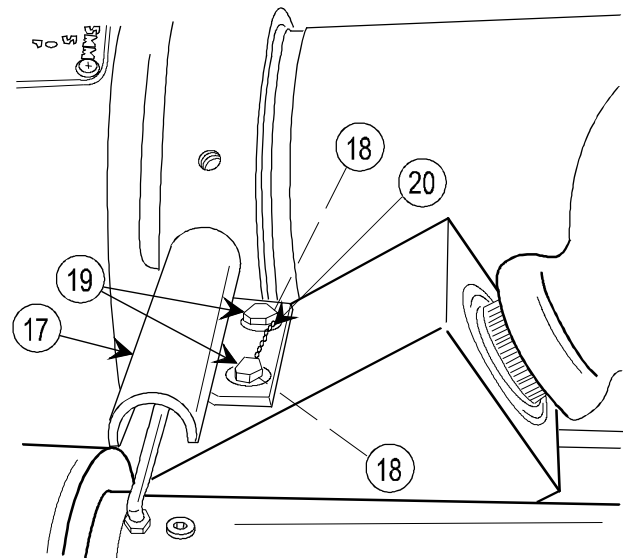
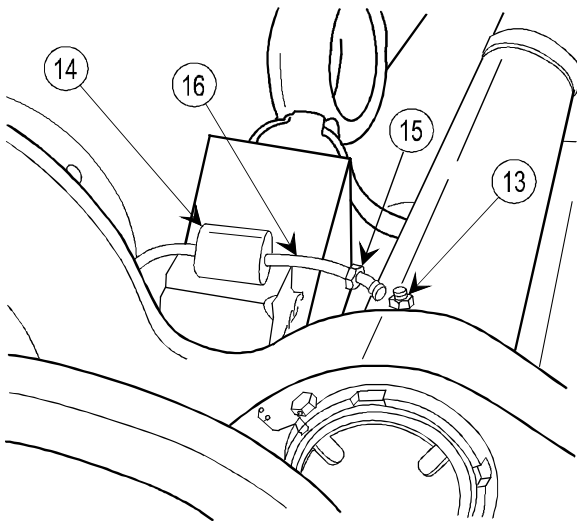

- 11 Wrap threads of two adapters (13) with tape. Install adapters (13) and tighten.
- 12 Install bushing (14).
- 13 Install two nuts (15) and tighten on two adapters (13). (Tube (16) is installed.)

- 14 Install retaining strap (17), two lockwashers (18), two cap screws (19), and lock wire (20) (item 33, appx B).

2-11. REPLENISHER CYLINDER ASSEMBLY—MAINTENANCE INSTRUCTIONS (cont)

INSTALLATION (cont)

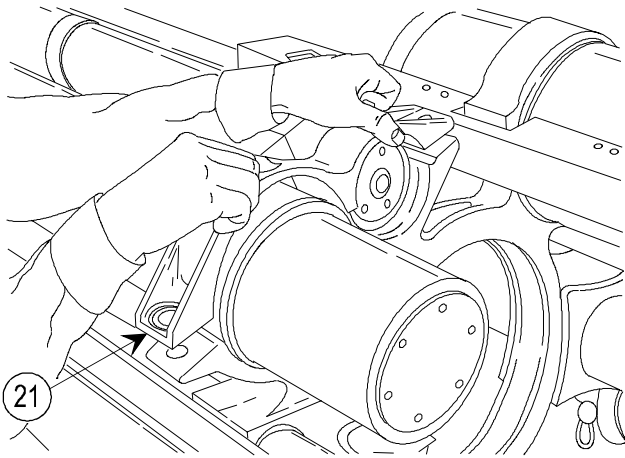

15 Install cap (21).

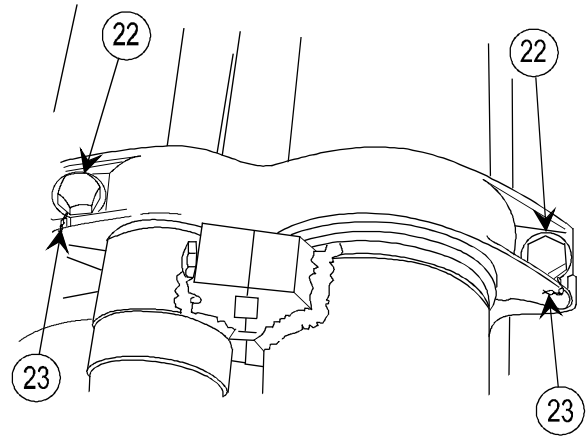

16 Install two bolts (22) and tighten.

17 Install lock wire (23) (item 34, appx B).

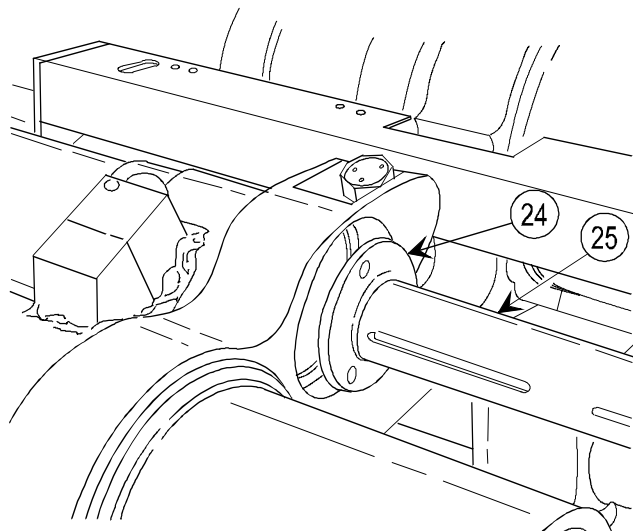

18 Install sleeve bushing (24) and oil reserve indicator (25) so that scale on oil reserve indicator (25) is visible from right side of weapon. Make sure slot on sleeve bushing (24) lines up with slot in oil reserve indicator (25).

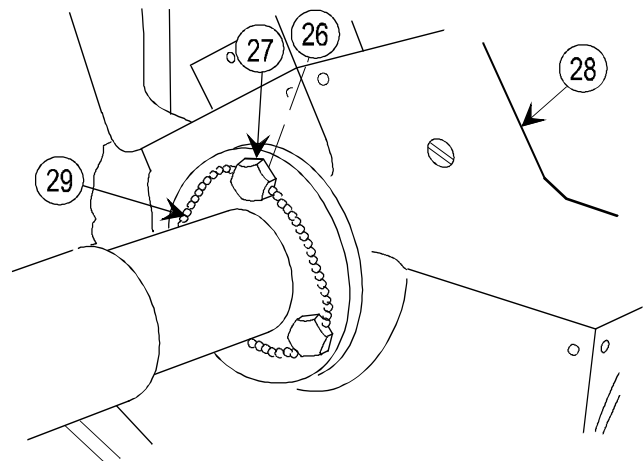

19 Install three lockwashers (26) and cap screws (27), and tighten in rear of front yoke (28).

20 Install lock wire (29) (item 34, appx B).

21 Install three lockwashers (30) and cap screws (31), and tighten in front of middle yoke (32).

22 Install lock wire (33) (item 34, appx B).

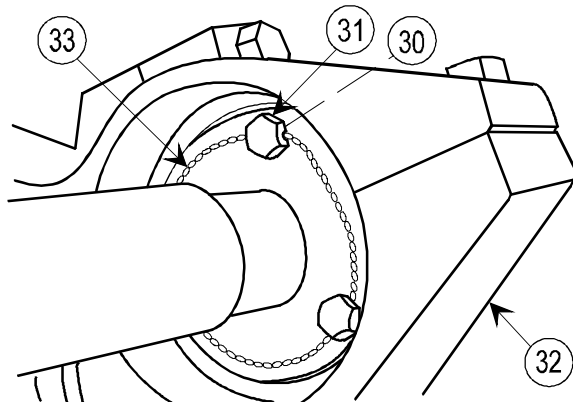

2-12. SLEEVE BEARING ASSEMBLY—MAINTENANCE INSTRUCTIONS

THIS TASK COVERS:

- a. Removal b. Disassembly c. Inspection/repair d. Reassembly e. Installation

INITIAL SETUP

Tools and Special Tools

Artillery and turret mechanic's ordnance tool kit (SC 5180-95-CL-A12)
Artillery field maintenance shop equipment (SC 4933-95-CL-A12)
M198 repairman field artillery tool kit (5911278)
Safety strut assemblies (2) (12008900)

Materials/Parts

Cotter pin (3) (MS24665-283)
Cotter pin (2) (MS24665-362)
Lock wire (item 34, appx B)

References

TM 9-1025-211-10
TM 9-1025-211-34P

Equipment Conditions

Cannon tube at zero elevation (TM 9-1025-211-10)
Travel lock assembly disconnected and attached to cradle assembly (TM 9-1025-211-10)

REMOVAL

WARNING

Before pulling M199 cannon out of battery, cradle assembly (1) must be secured to bottom carriage assembly (2) to prevent accidental elevation of M199 cannon which could result in injury.

NOTE

Cannon tube may be removed in some illustrations for clarity.

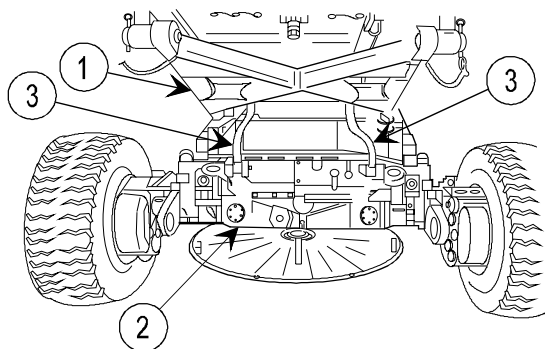

- 1 Secure cradle assembly (1) to bottom carriage assembly (2) (p 2-23) with safety strut assemblies (3).

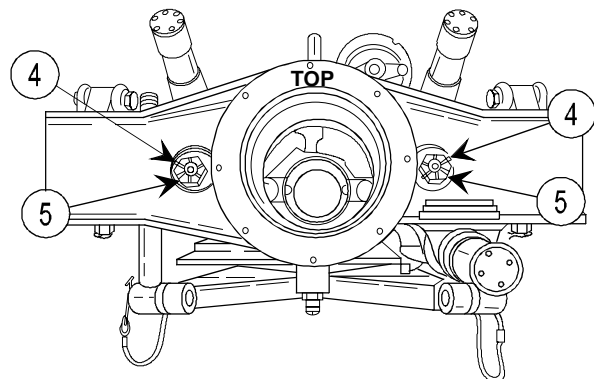

- 2 Remove two cotter pins (4) and two nuts (5).

2-12. SLEEVE BEARING ASSEMBLY—MAINTENANCE INSTRUCTIONS (cont)

REMOVAL (cont)

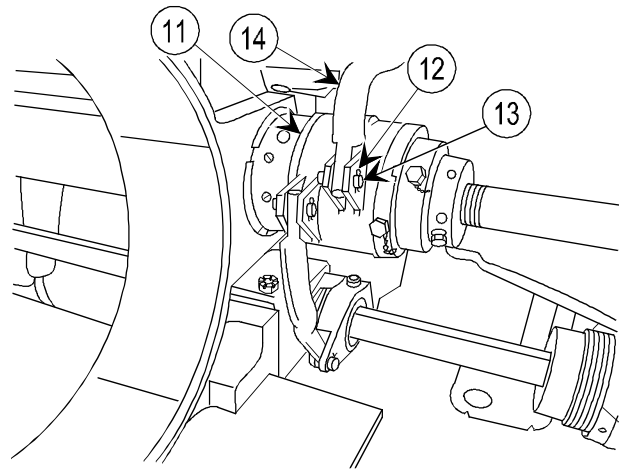
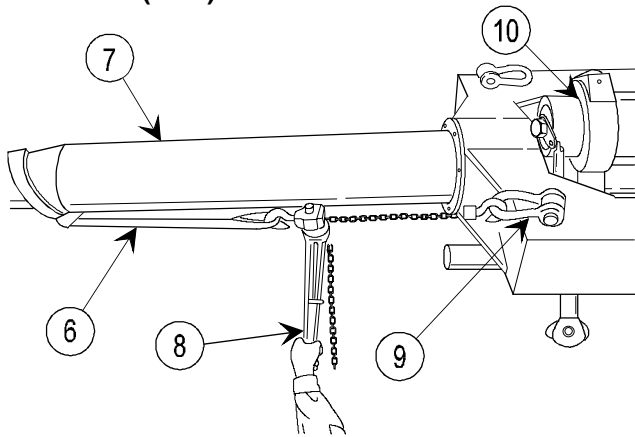

- 3 Loop cannon tube sling (6) around front end of cannon tube (7).
- 4 Hook to mechanical puller (8), and position other chain end of mechanical puller on left front clevis assembly (9).
- 5 Pull cannon tube (7) and recoil mechanism (10) rearward far enough to remove sleeve bearing assembly (11) (approximately 12 to 16 in. (30 to 40 cm)).
- 6 Remove cannon tube sling (6) and mechanical puller (8).

- 7 Remove cotter pin (12) and straight pin (13) from rigid connecting link (14) and sleeve bearing assembly (11).

- 8 Remove two cotter pins (15) and two straight pins (16) from rigid connecting link (17) and sleeve bearing assembly (11).
- 9 Remove rigid connecting link (17).
- 10 Remove lock wire (18) and setscrew (19) from nut (20).
- 11 Remove lock wire (21) and setscrew (22) from nut (23).
- 12 Remove nut (20) and sleeve bearing assembly (11) from recoil cylinder assembly (24).

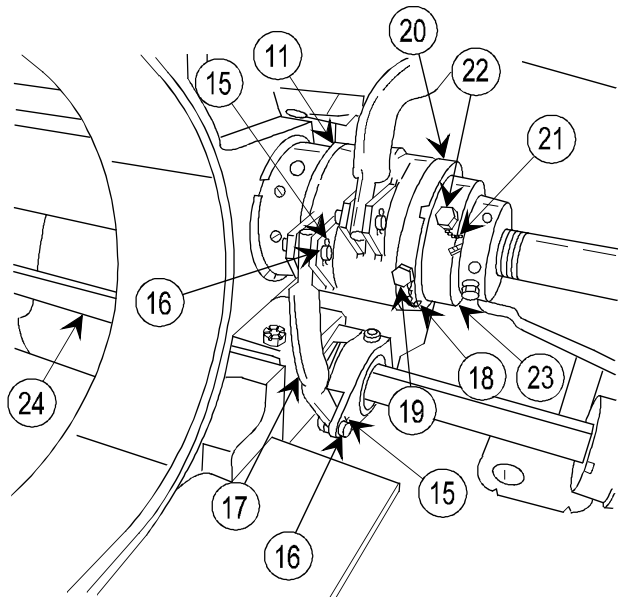

DISASSEMBLY

Separate two bushings (1) and adapter (2).

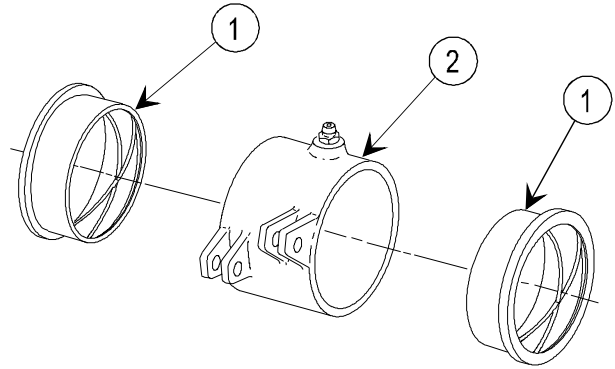

INSPECTION/REPAIR

1 Check for broken, missing, or damaged parts.

2 Repair is by replacement of authorized parts (TM 9-1025-211-34P).

3 Replace sleeve bearing if adapter is cracked or broken.

REASSEMBLY

Reassemble adapter (1) and two bushings (2).

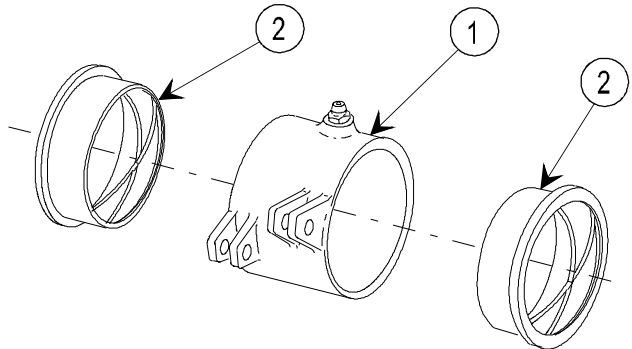

INSTALLATION

NOTE

Cannon tube may be removed from some illustrations for clarity.

1 Install sleeve bearing assembly (1).

2 Install nut (2) and align setscrew hole with pilot hole in recoil cylinder assembly (3). (Sleeve bearing assembly (1) must rotate freely after it and nut (2) are installed.)

3 Install and tighten setscrew (4), and install lock wire (5).

4 Install and tighten setscrew (6) and install lock wire (7).

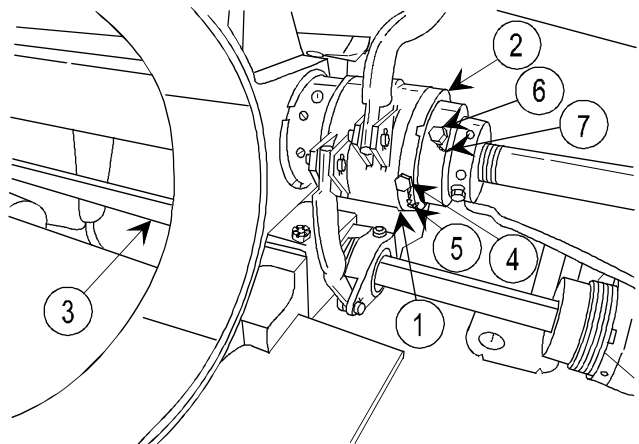

2-12. SLEEVE BEARING ASSEMBLY—MAINTENANCE INSTRUCTIONS (cont)

INSTALLATION (cont)

CAUTION

Heads of straight pins (8) and (9) must be pointed toward breech mechanism assembly.

- 5 Install rigid connecting link (10) and two straight pins (8).
- 6 Install two new cotter pins (11).
- 7 Connect rigid connecting link (12) to sleeve bearing assembly (1).
- 8 Install straight pin (9) and new cotter pin (13).

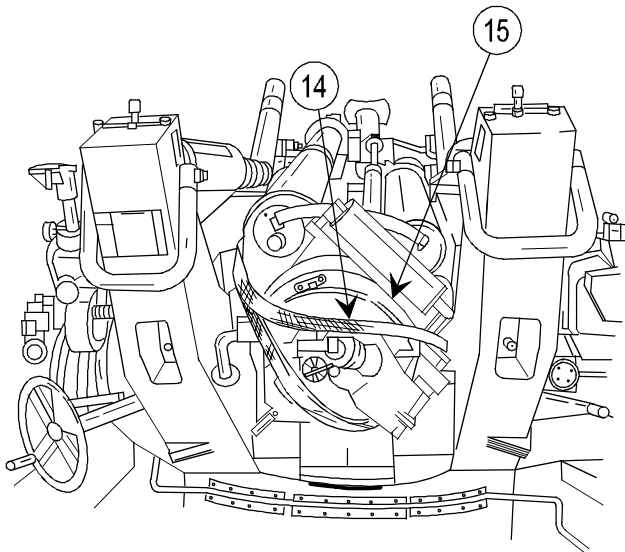
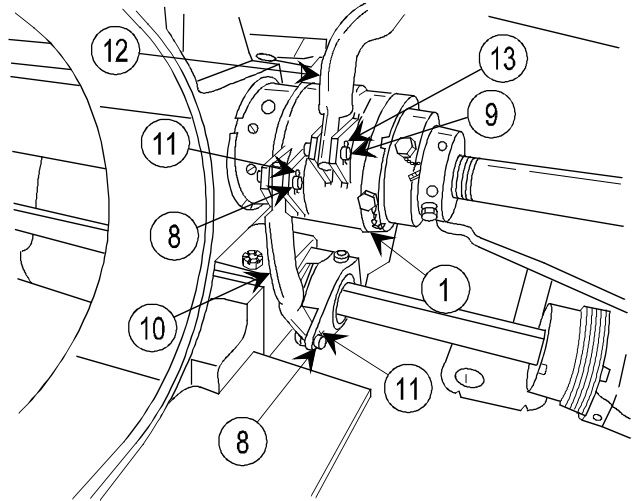

- 9 Attach cannon tube sling (14) to breech mechanism assembly (15).
- 10 Hook to mechanical puller (16) to cannon tube sling (14), and attach other end of mechanical puller to left front clevis assembly (17).
- 11 Operate mechanical puller (16) to ease recoil mechanism (18) and cannon tube (19) forward, tight against cradle assembly (20).

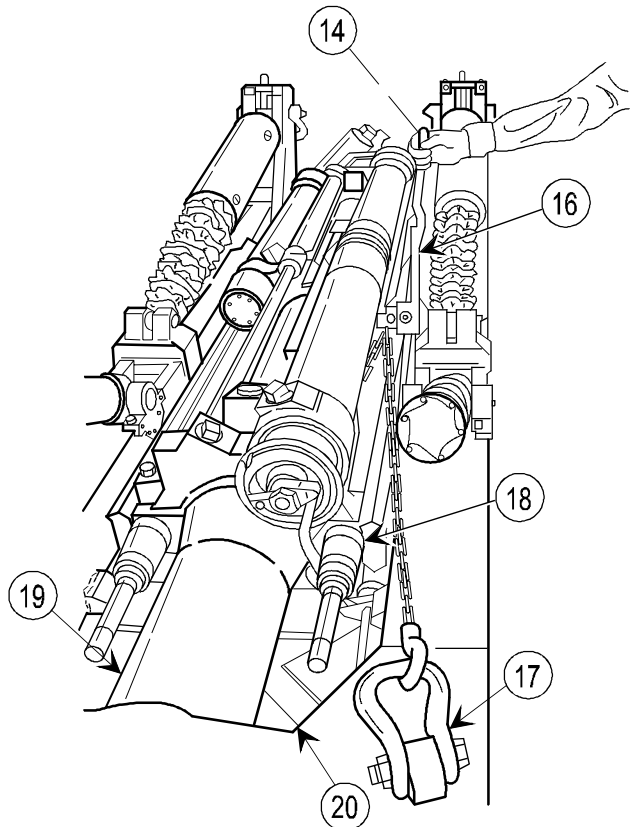

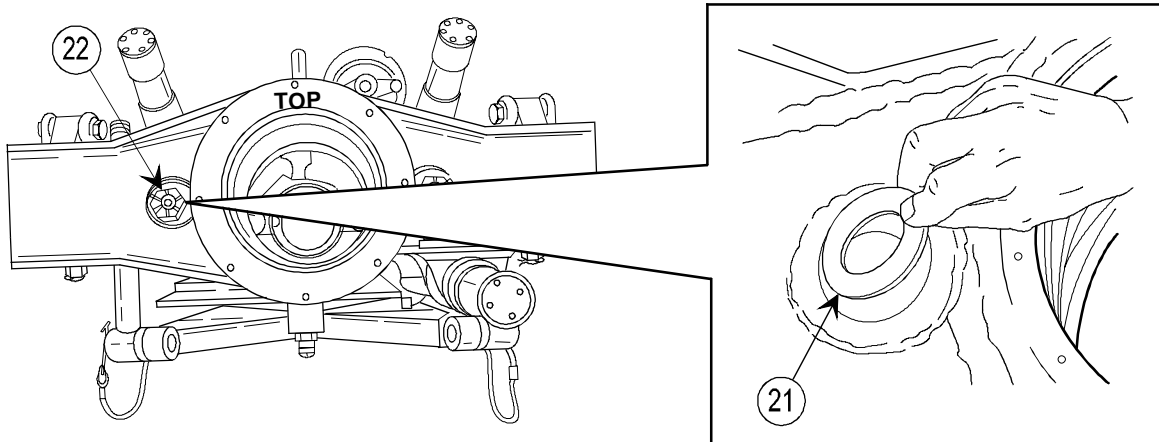

NOTE

Make sure the four flat washers (21) are in place before installing nuts (22).

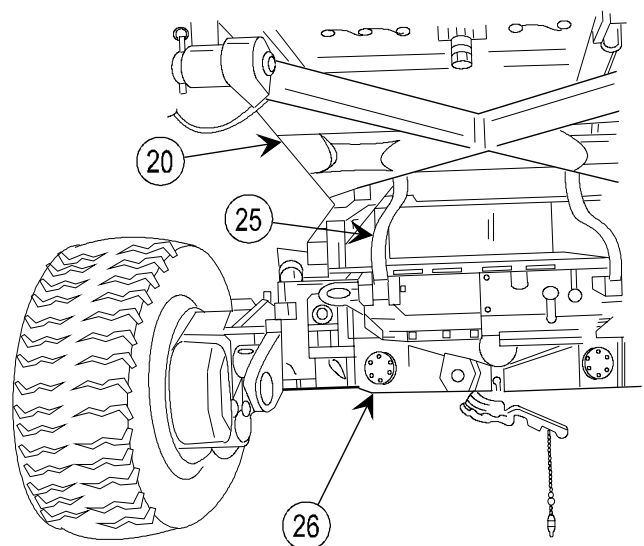
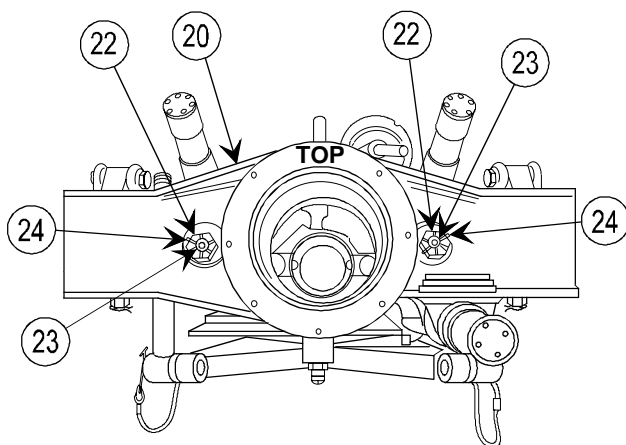

12 Screw two nuts (22) onto rods (23) until snug against cradle assembly (20), then back off one notch.

13 Install new cotter pins (24) through nut (22) on each rod (23).

14 Remove safety strut assemblies (25) from cradle assembly (20) and bottom carriage assembly (26) (p 2-23).

15 Remove mechanical puller and cannon tube sling.

2-13. RECOIL CYLINDER ASSEMBLIES—MAINTENANCE INSTRUCTIONS

THIS TASK COVERS:

- a. Removal b. Disassembly c. Inspection/repair d. Reassembly e. Installation

INITIAL SETUP

Tools and Special Tools

- Artillery field maintenance shop equipment (SC 4933-95-CL-A12)
- Fabricated tool (figure C-1, appx C)
- M198 repairman field artillery tool kit (5911278)
- Safety strut assemblies (2) (12008900)
- Spanner wrench (12008909)
- Spanner wrench (12008913)

Materials/Parts

- Cleaning compound (item 7, appx B)
- Gasket (8403400)
- Gasket (2) (12007679)
- Lock wire (item 34, appx B)
- Oil (item 14, appx B)
- Paint (CARC) (item 18, appx B)
- Paint remover (CARC) (item 24, appx B)
- Plastic pellet (2) (8436778)
- Prefomed packing (4) (MS28775-240)
- Primer (CARC) (item 21, appx B)
- Ring spacer (4) (12007694)
- Screw (8) (12007651)
- Wiping rag (item 22, appx B)
- WTR grease (item 11, appx B)

Personnel Required: 2

- Artillery repairmen to replace recoil cylinder assemblies

References

- TM 43-0139
- TM 9-1025-211-10
- TM 9-1025-211-34P

Equipment Conditions

- 2-23 M199 cannon removed
- 2-58 Nitrogen pressure released
- 2-58 Oil reserves drained
- 2-23 Recoil mechanism ballistic shield removed
- 2-58 Recoil mechanism removed
- 2-95 Sleeve bearing assembly removed from left recoil cylinder assembly

REMOVAL

WARNING

For safety precautions, prior to beginning any painting operations, refer to TM 43-0139, Improper application or removal of CARC paint can be extremely hazardous to your health.

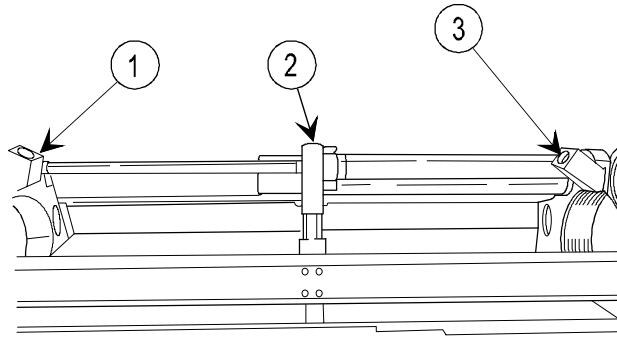

NOTE

Use paint stripper and scraper to strip all paint from recoil cylinder assembly where it is thicker in diameter than remainder of the recoil cylinder assembly. This is immediately behind front and middle yokes (1) and (2) and immediately in front of rear yoke (3). Clean outside diameter of recoil cylinder assembly with cleaning compound to eliminate any contamination.

There are two recoil cylinder assemblies, but the maintenance procedures are written for one recoil cylinder assembly. Procedures are identical for both, except for the sleeve bearing assembly on the left recoil cylinder assembly.

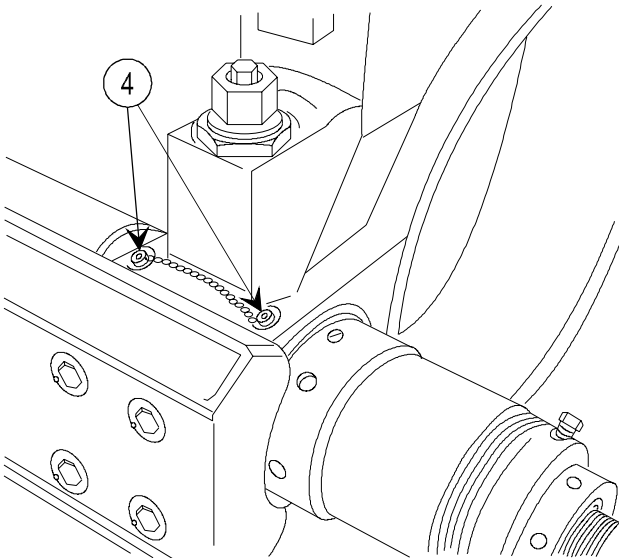

1 Remove lock wire and two bolts (4).

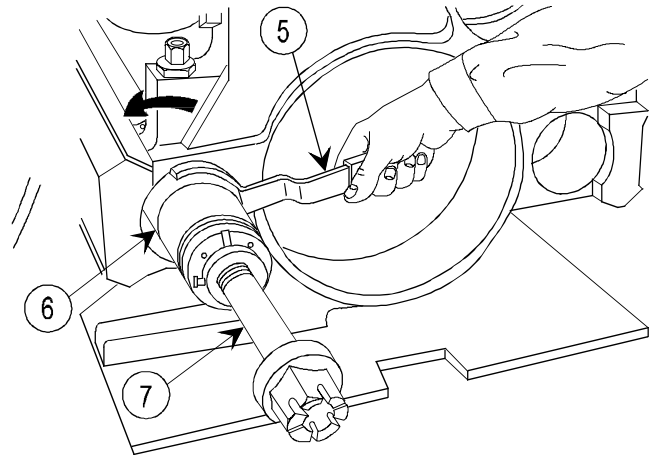

2 Use spanner wrench (5) to unscrew ring (6) and remove from recoil cylinder assembly (7).

2-13. RECOIL CYLINDER ASSEMBLIES—MAINTENANCE INSTRUCTIONS (cont)

REMOVAL (cont)

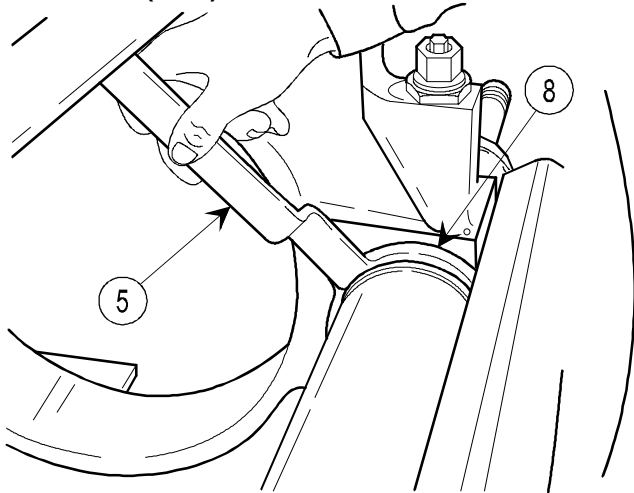

- 3 Unscrew ring (8), using spanner wrench (5), and slide back approximately 12 in. (30 cm).

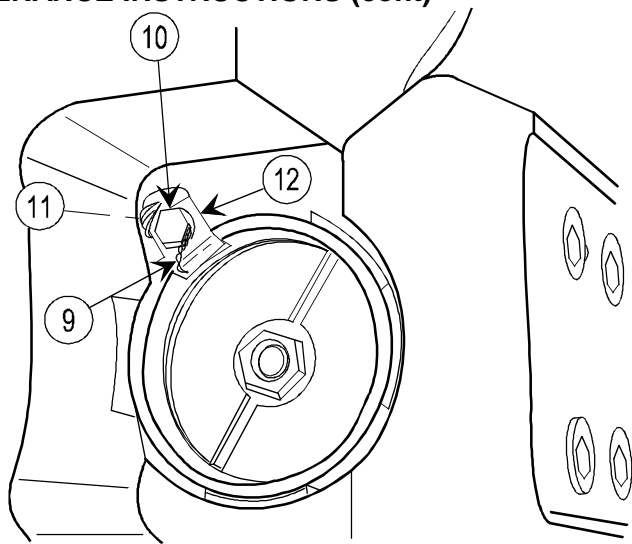

- 4 Remove lock wire (9), bolt (10), lockwasher (11), and restraint key (12).

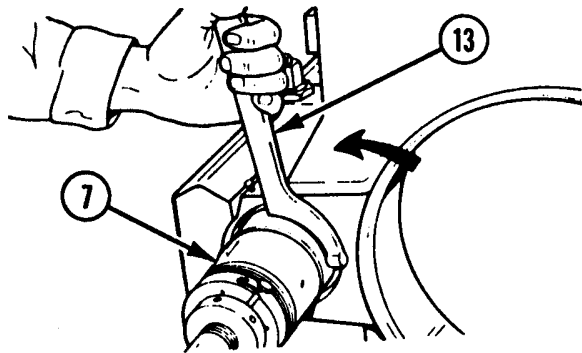

- 5 Using spanner wrench (13), turn recoil cylinder assembly (7) 1/8 turn counterclockwise.

- 6 Drain oil (p 2-58) into a container, using funnel (14). (Approximately 2 to 3 gal. (8 to 11 liter) of oil will drain.)

- 7 Pull recoil cylinder assembly (7) forward approximately 3 in. (8 cm), exposing preformed packing (15) and ring spacer (16).

- 8 Remove lock wire (17) and setscrew (18) to prevent damage to new preformed packing (15) during installation.

- 9 Remove preformed packing (15) and ring spacer (16).

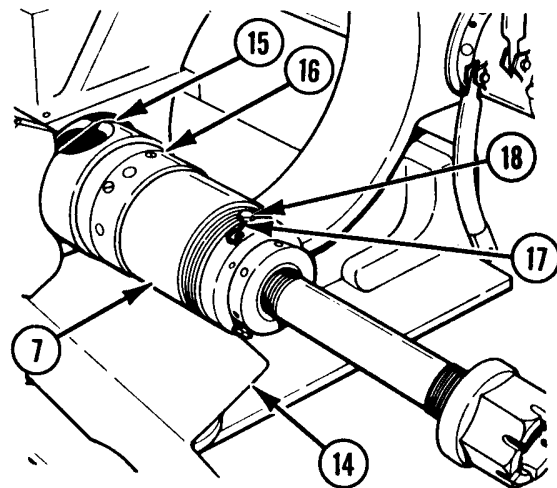

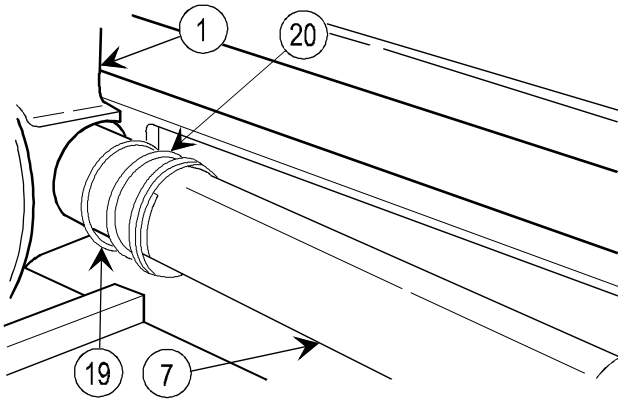

- 10 Move recoil cylinder assembly (7) back into position, exposing preformed packing (19) and ring spacer (20) at rear of front yoke (1).
- 11 Cut preformed packing (19) and ring spacer (20) from recoil cylinder assembly (7).

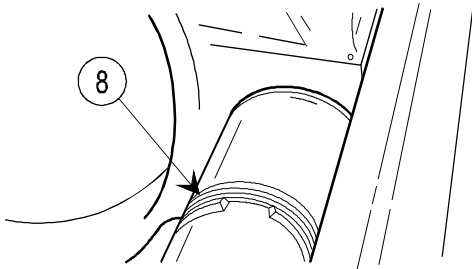

CAUTION

Do not damage surface of yokes (1, 2, and 3).

- 15 Remove recoil cylinder assembly (7).

CAUTION

Do not use air hose on front yoke (1). This will cause contamination of oil.

- 17 Clean middle and front yokes (2) and (1) with wiping rag.
- 18 After cleaning, inspect inside diameter.
- 19 Clean and inspect outside surface of recoil cylinder assembly (7) where yokes (1, 2, and 3) mate. Lubricate threads with WTR grease.

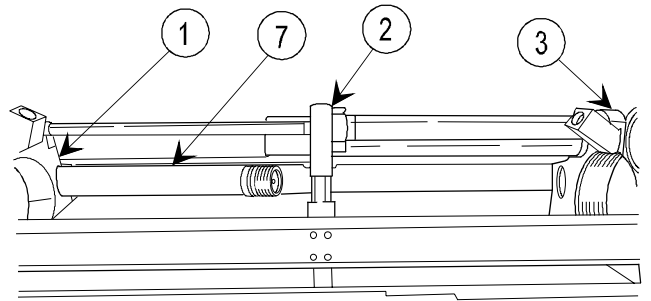

- 12 Move recoil cylinder assembly (7) forward until end clears middle yoke (2).
- 13 Remove ring (8).
- 14 Clean recoil cylinder assembly (7) using cleaning compound.

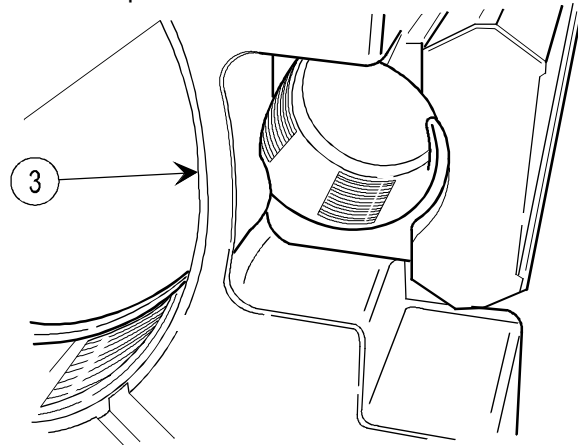

- 16 Clean rear yoke (3) with wire brush (TM 9-1025-211-10), inspect threads, and apply light coat of WTR grease to threads.

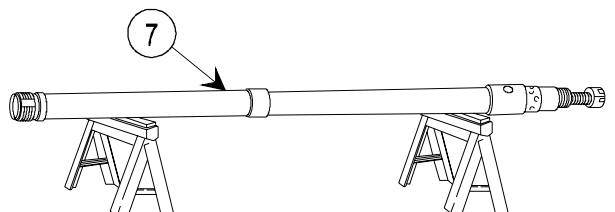
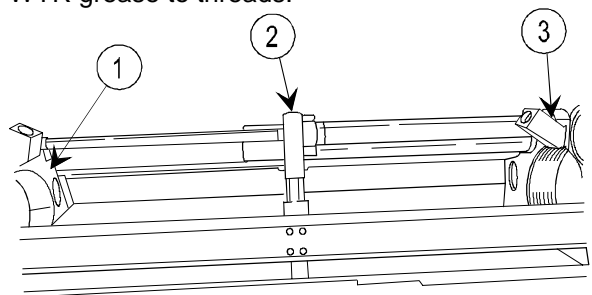

2-13. RECOIL CYLINDER ASSEMBLIES—MAINTENANCE INSTRUCTIONS (cont)

REMOVAL (cont)

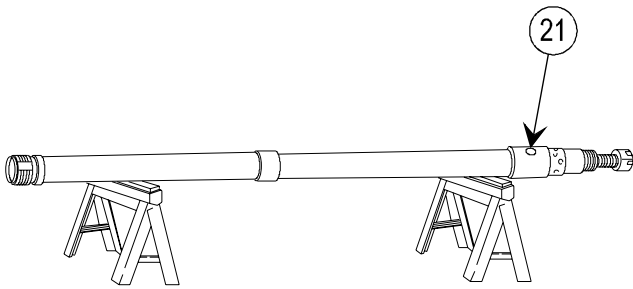

NOTE

Cover oil port (21) with clean cloth to prevent contamination of oil while recoil cylinder is removed.

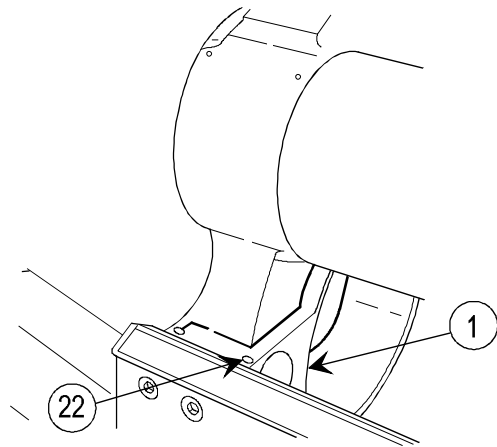

- 20** Remove two plastic pellets (22) from front yoke (1).

DISASSEMBLY

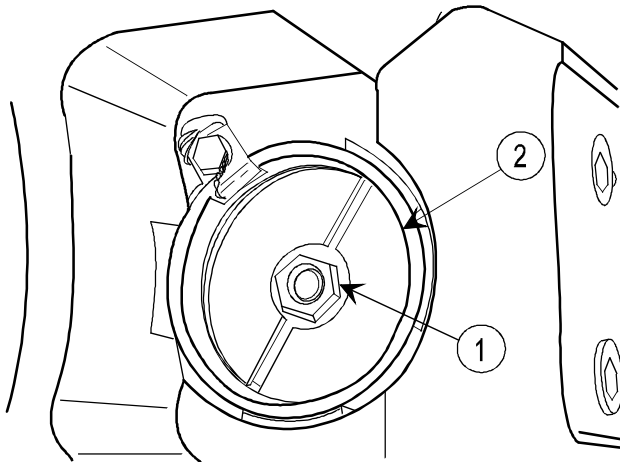

NOTE

Procedures are written for one recoil cylinder assembly, but apply to both.

- 1** Remove safety relief valve (1) and adapter bushing (2).

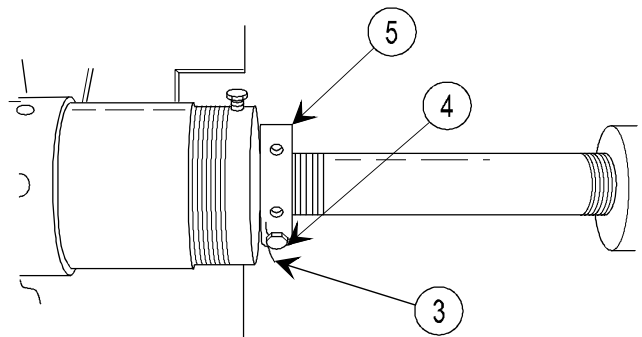

- 2** Remove lock (3) wire from setscrew (4).
3 Unscrew and remove setscrew (4) from nut (5).

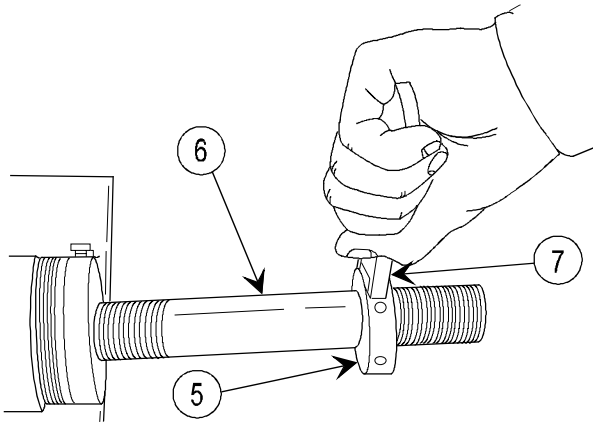

- 4 Remove nut (5) from rod (6), using spanner wrench (7).

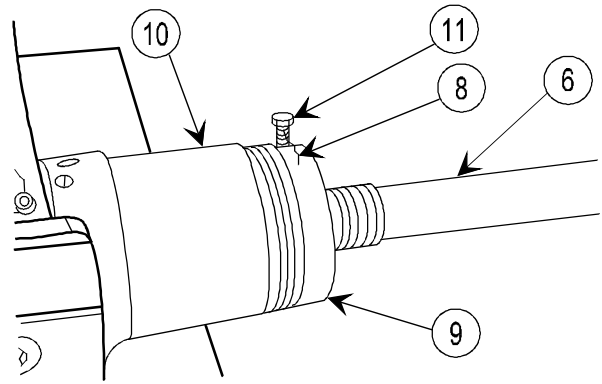

- 5 Cut and remove lock wire (8).

NOTE

Scribe line on nut (9) and recoil cylinder assembly (10) for proper installation.

- 6 Remove setscrew (11) from nut (9).
7 Unscrew and remove nut (9) from rod (6).

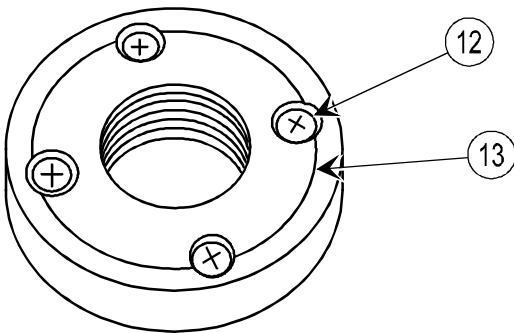

- 8 Remove four screws (12) and gasket (13).

- 9 Remove setscrew (14) and gasket (15).

REASSEMBLY

- 1 Install new gasket (1) and setscrew (2).

INSPECTION/REPAIR

- 1 Check for broken, missing, or damaged parts.
2 Repair is by replacement of authorized parts (TM 9-1025-211-34P).
3 Replace recoil cylinder assembly if more than two reserves of oil leak from piston on rod end per day.

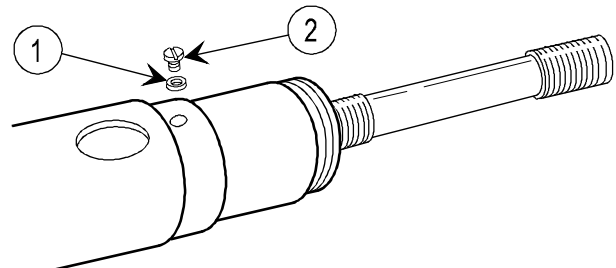

2-13. RECOIL CYLINDER ASSEMBLIES—MAINTENANCE INSTRUCTIONS (cont)

REASSEMBLY (cont)

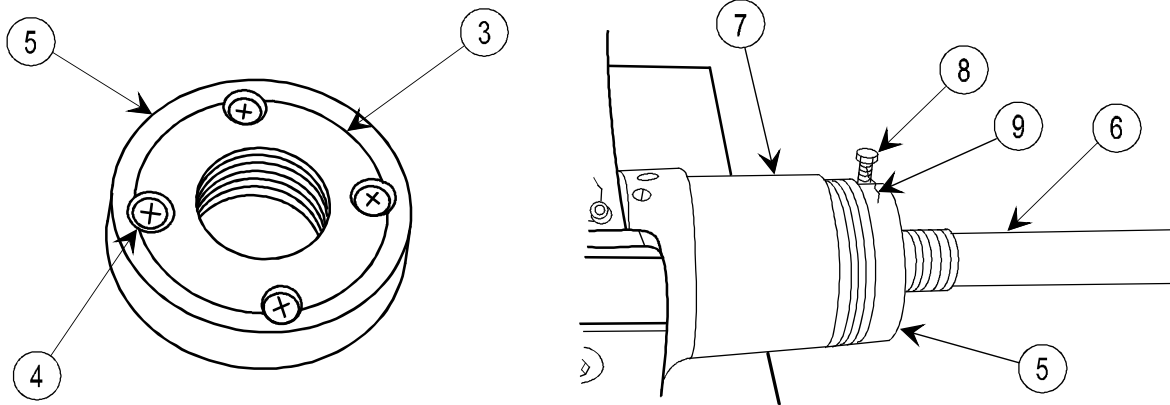

- 2 Install new gasket (3) and four new screws (4) on nut (5); install nut (5) on rod (6) facing recoil cylinder assembly (7); and tighten so setscrew (8) takes seat at drilled hole in rod (6). Aline scribe marks.
- 3 Install and tighten setscrew (8) and install lock wire (9).

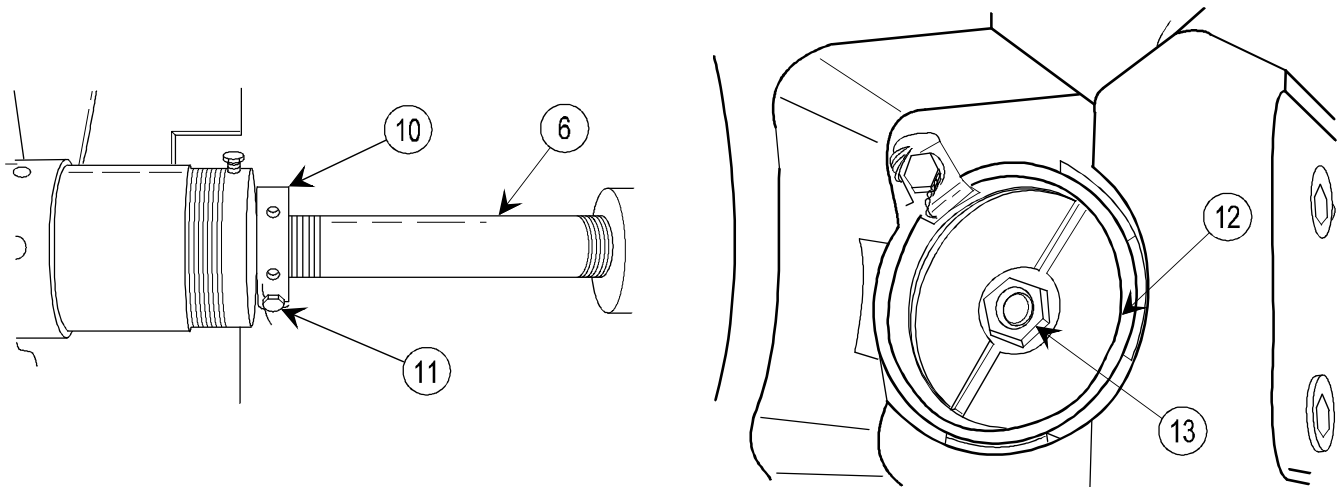

- 4 Install nut (10) on rod (6), and adjust to position where hole for setscrew (11) alines with drilled indentation in rod.
- 5 Install and tighten setscrew (11).

NOTE

If recoil cylinder (7) or nut (10) were replaced, perform adjustment procedure (p 2-86) steps 1 thru 17 as required.

- 6 Install adapter bushing (12) and safety relief valve (13).

INSTALLATION

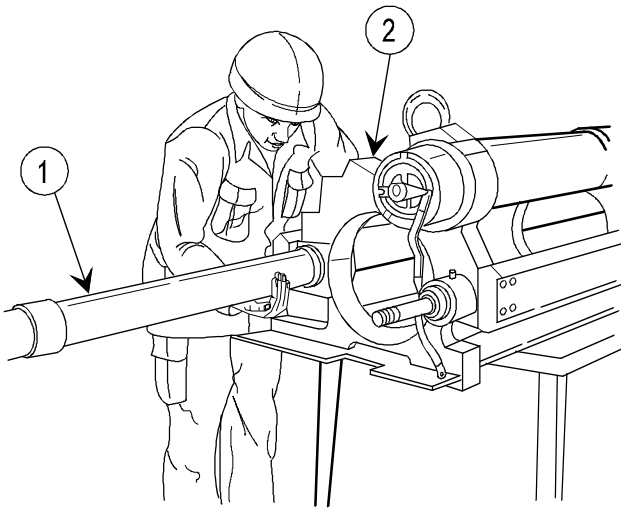

- 1 Insert the threaded end of recoil cylinder assembly (1) through the front yoke (2) approximately 12 in. (30 cm).

CAUTION

Do not damage the preformed packing (3) or ring spacer (4).

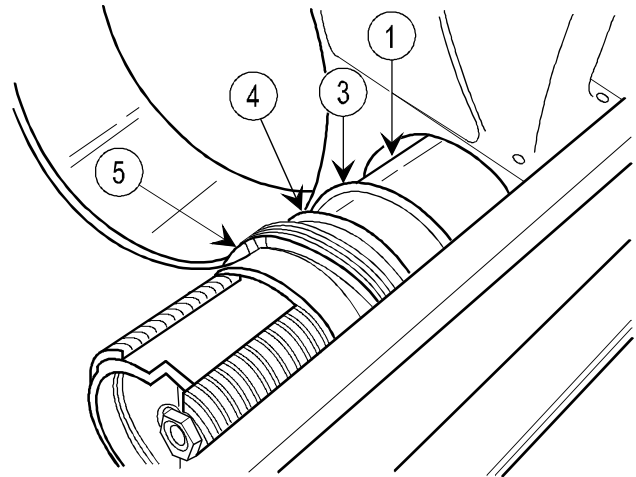

NOTE

Ensure ring (5) is installed with slots facing to the rear end of recoil cylinder assembly (1).

- 2 Assemble new preformed packing (3), new ring spacer (4), and ring (5) over the rear end of recoil cylinder assembly (1), and slide forward.

CAUTION

Support recoil cylinder assembly during installation. Do not slide it through the front yoke. Seal area of front yoke could be damaged, causing front seals to leak.

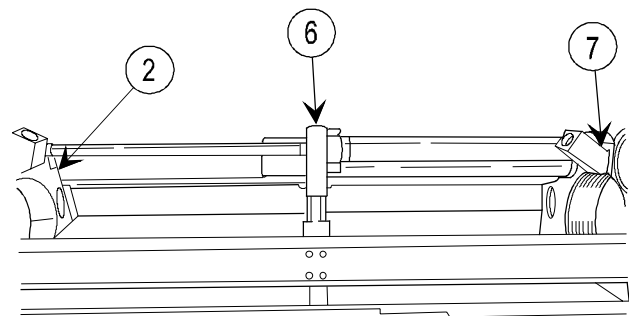
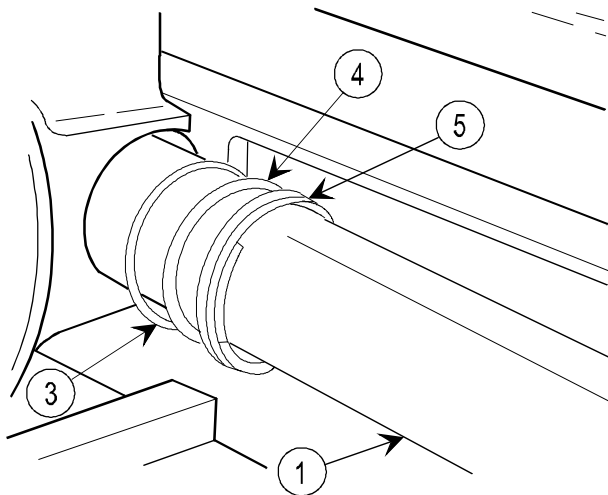

- 3 Lift and support recoil cylinder assembly (1) and move to the rear through the middle yoke (6) to the rear yoke (7), while at the same time keeping preformed packing (3), ring spacer (4), and ring (5) in the immediate area behind the front yoke (2). Apply WTR grease to rear yoke and recoil cylinder threads.

2-13. RECOIL CYLINDER ASSEMBLIES—MAINTENANCE INSTRUCTIONS (cont)

INSTALLATION (cont)

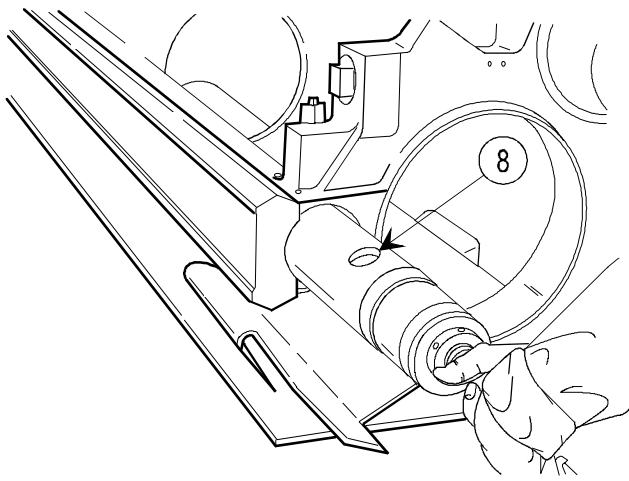

- 4 Before positioning in rear yoke, place the communicating hole (8) on top; and fill with oil. Ensure oil is clean and all air pockets are removed.

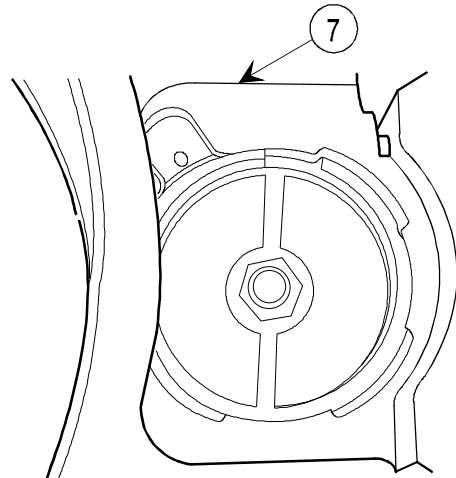

- 5 Position flush with rear yoke (7).

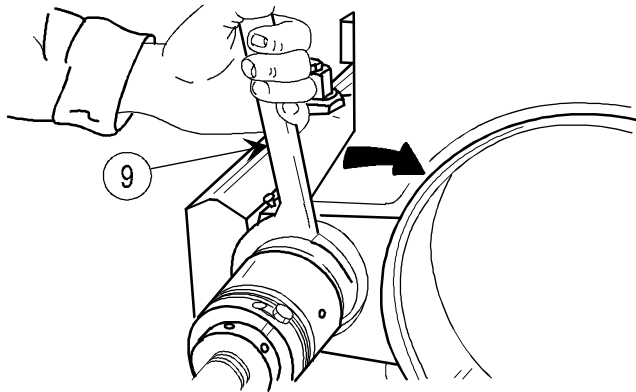

- 6 Turn recoil cylinder assembly 1/8 turn, using spanner wrench (9).

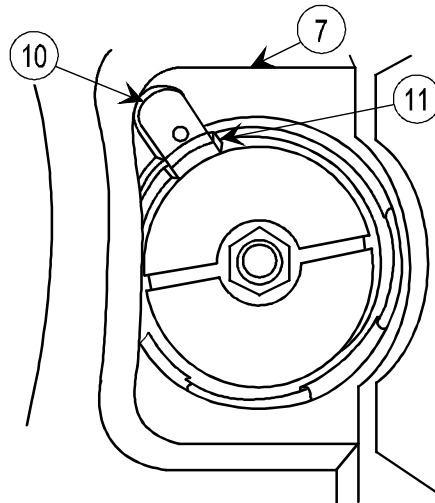

- 7 Adjust so key slot (10) at the rear of rear yoke (7) aligns with slot (11).

- 8 Install restraint key (12), lockwasher (13), bolt (14), and lock wire (15).

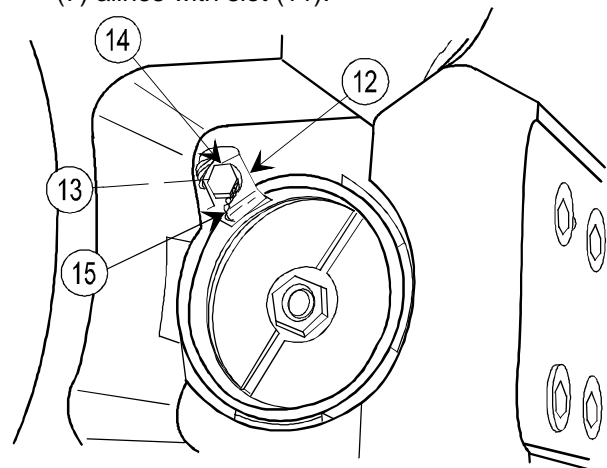

CAUTION

Do not scratch or cut preformed packing. It is important that the preformed packing seats completely. If preformed packing is stretched during installation and does not properly seat, the preformed packing will be cut when rings are installed.

NOTE

Use special fabricated tool (16) (figure C-1, appx C) when installing new preformed packing. Assemble and seat the new preformed packing into place by pushing in the bottom, then top, then side to side. Repeat this action until preformed packing is seated. Apply WTR to preformed packing prior to installation.

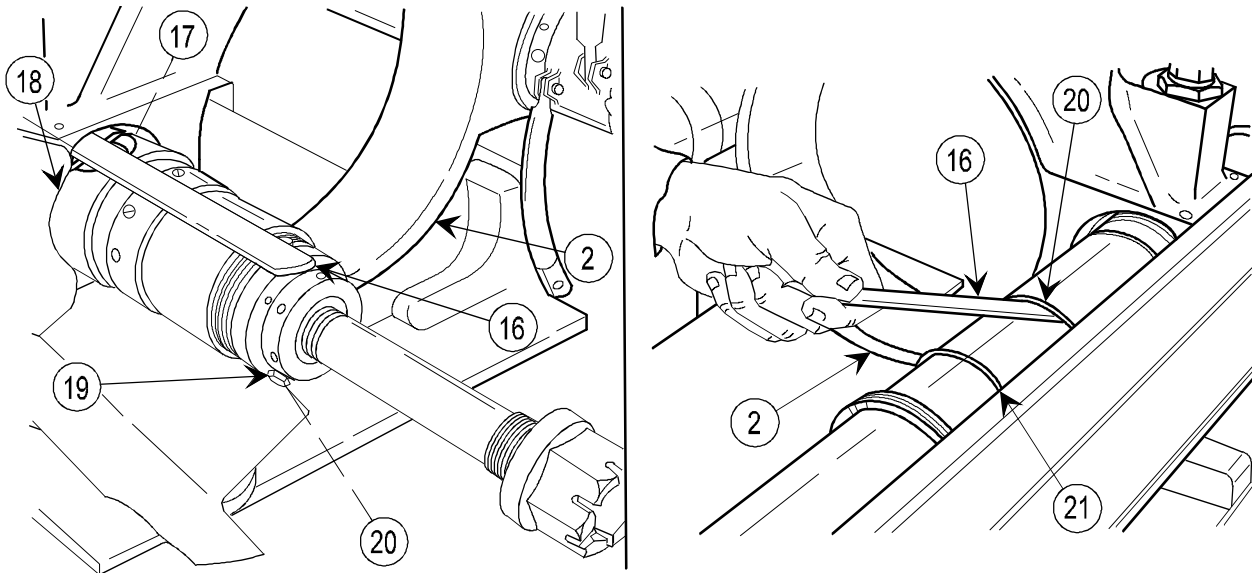

- 9 Using fabricated tool (16), install new preformed packing (17) and ring spacer (18) in front of front yoke (2).
- 10 Install setscrew (19) and lock wire.
- 11 Using fabricated tool (16), install new preformed packing (20) and ring spacer (21) in rear of front yoke (2).

- 12 Lightly coat ring (22) with WTR grease, and loosely screw into front yoke (2).
- 13 Using spanner wrench (23), tighten ring (22); then back off 1/8 to 1/4 turn.

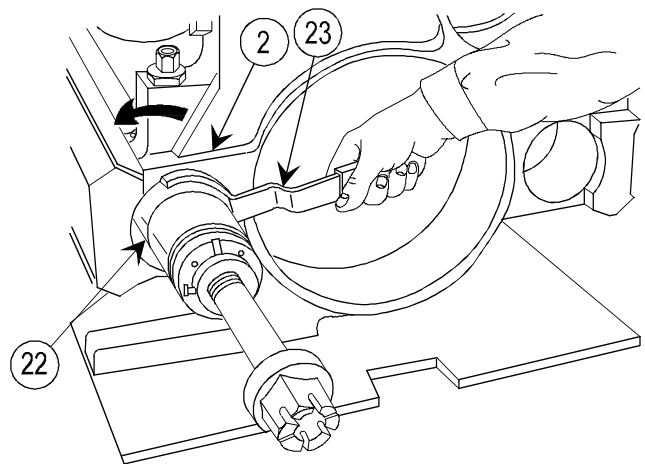

2-13. RECOIL CYLINDER ASSEMBLIES—MAINTENANCE INSTRUCTIONS (cont)

INSTALLATION (cont)

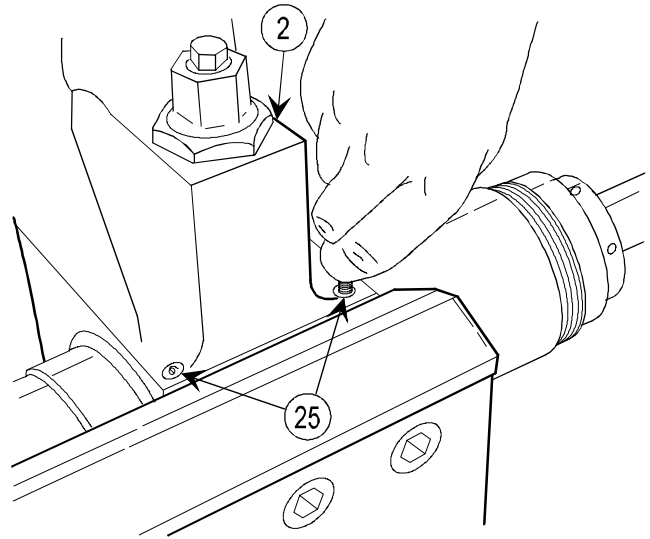
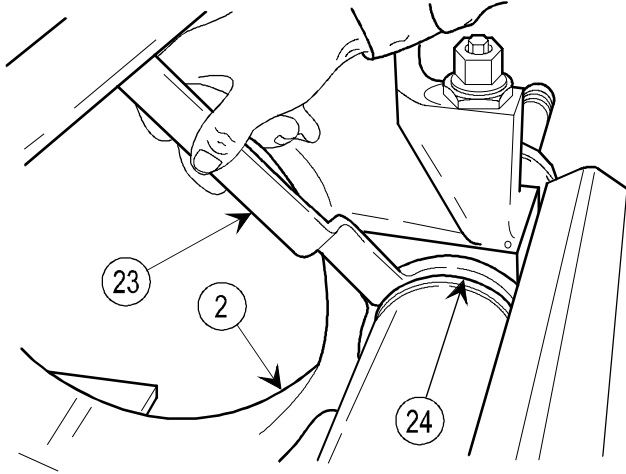

- 14 Lightly coat ring (24) with WTR grease and screw into front yoke (2).
- 15 Using spanner wrench (23), tighten ring (24), then back off 1/8 to 1/4 turn.
- 16 Insert two new plastic pellets (25) into front yoke (2).
- 17 Install two bolts (26) and lock wire (27).

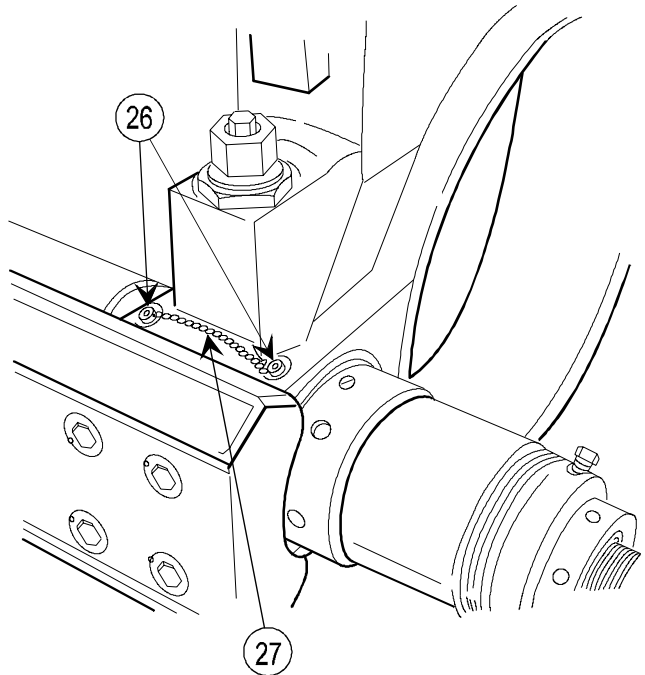

NOTE

Clearance between nut (28) and nut (29) is adjusted as required during installation of the recoil mechanism (p 2-86). Setscrew (30) and lock wire (31) need not be installed until adjustment is made.

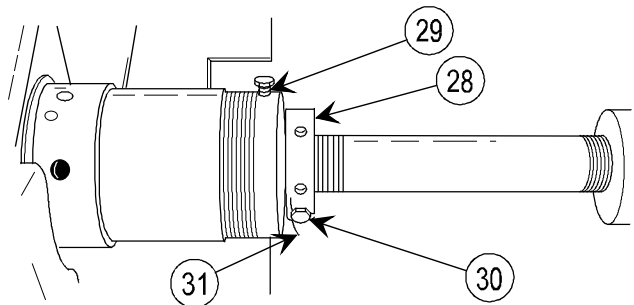

2-14. RECUPERATOR CYLINDER ASSEMBLY AND PARTS—MAINTENANCE INSTRUCTIONS

THIS TASK COVERS:

- | | | |
|---------------|-----------------|----------------------|
| a. Removal | b. Disassembly | c. Inspection/repair |
| d. Reassembly | e. Installation | |

INITIAL SETUP

Tools and Special Tools

Artillery field maintenance shop equipment (SC 4933-95-CL-A12)
Fabricated tool (figure C-1, appx C)
Fabricated tool (figure C-23, appx C)
M198 repairman field artillery tool kit (5911278)
Slings (8735439 or 8735440)
Spanner wrench (12008906)
3-ton hoist

Materials/Parts

Abrasive cloth (item 8, appx B)	Plastic pellet (4) (8436778)
Cleaning compound (item 7, appx B)	Primer (CARC) (item 21, appx B)
Cotter pin (4) (MS24665-134)	Preformed packing (2) (MS28775-442)
Cotter pin (2) (MS24665-283)	Preformed packing (MS28778-4)
Lock wire (item 34, appx B)	Preformed packing (MS28778-12)
Paint (CARC) (item 18, appx B)	Ring spacer (2) (12007781)
Paint remover (CARC) (item 24, appx B)	Wiping rag (item 22, appx B)
	WTR grease (item 11, appx B)

Personnel Required: 2

Artillery repairmen to operate 3-ton hoist and remove recuperator cylinder assembly

References

TM 43-0139
TM 9-1025-211-10
TM 9-1025-211-34P

Equipment Conditions

NOTE

Replacement of restrictor check valve and attaching parts does not require removal of the M45 recoil mechanism or M199 cannon.

2-23 M199 cannon removed
2-58 Recoil mechanism removed
2-58 Oil reserves drained

General Safety Instructions

WARNING

All lifting devices must be checked in accordance with local Standing Operating Procedure (SOP) to make sure they are in good working condition before starting the lifting operation.

2-14. RECUPERATOR CYLINDER ASSEMBLY AND PARTS—MAINTENANCE INSTRUCTIONS (cont)

REMOVAL

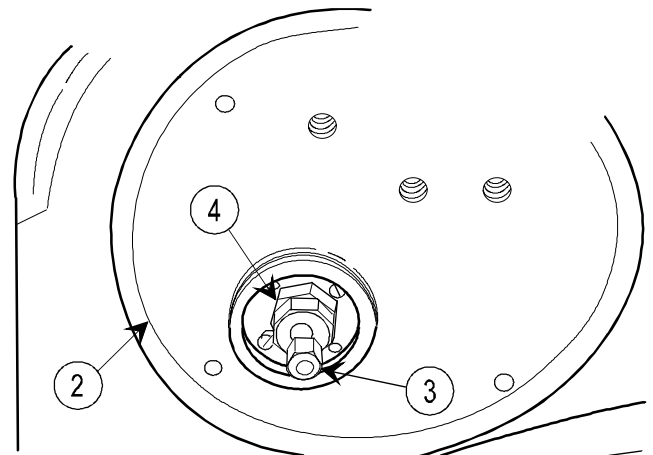
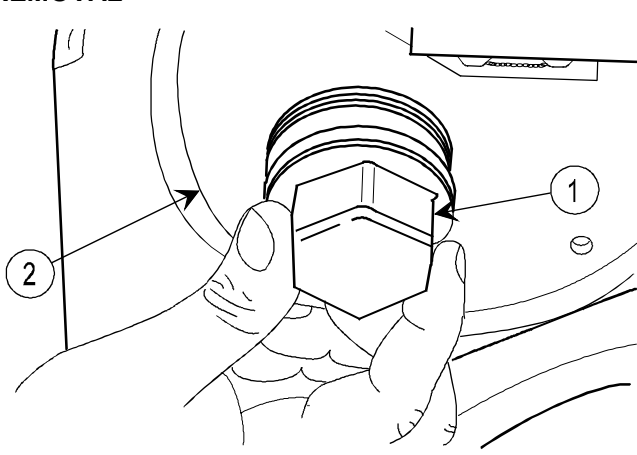

- 1 Unscrew cap (1) and remove from recuperator cylinder assembly (2).
- 2 Unscrew valve cap (3) and remove.

WARNING
 Failure to bleed off all pressure in the recuperator cylinder assembly (2) could lead to severe injury.

- 3 Slightly loosen valve nut on check valve (4) until nut becomes tight; then open slowly to bleed all nitrogen pressure from recuperator cylinder assembly (2).
- 4 Remove lock wire (5), three capscrews (6), and three lockwashers (7) from cover (8).
- 5 Remove lock wire (9), three capscrews (10), three lockwashers (11), and cover (8).

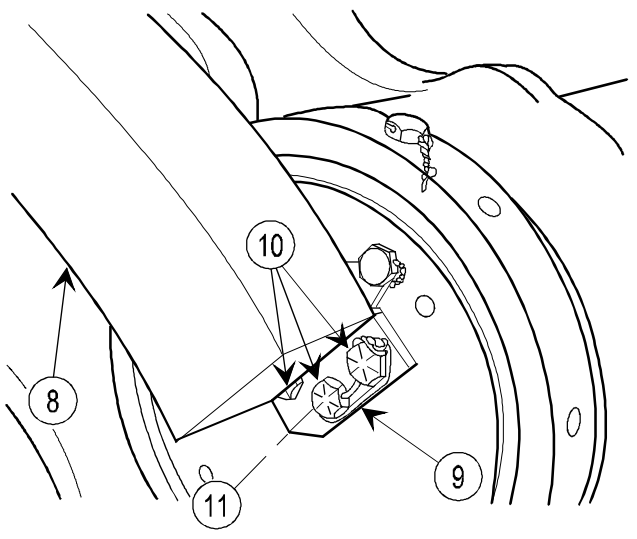
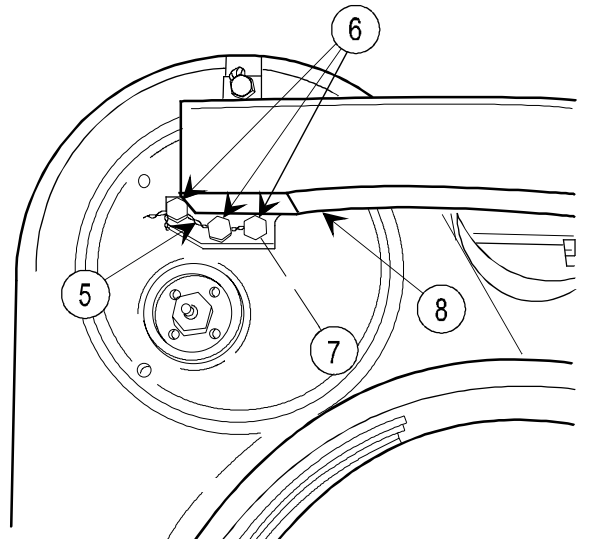

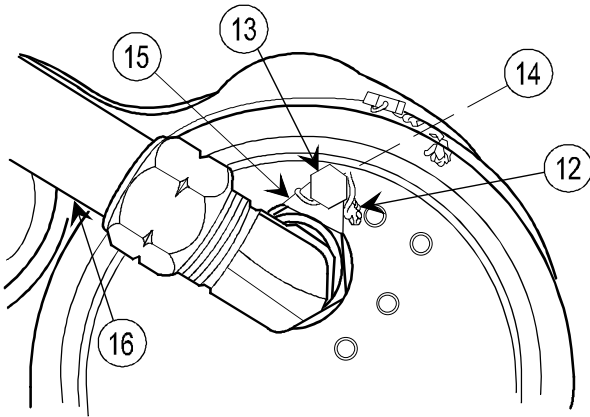

- 6** Remove lock wire (12), two cap screws (13), two lock washers (14), and two stops (15) from both ends of tube (16).

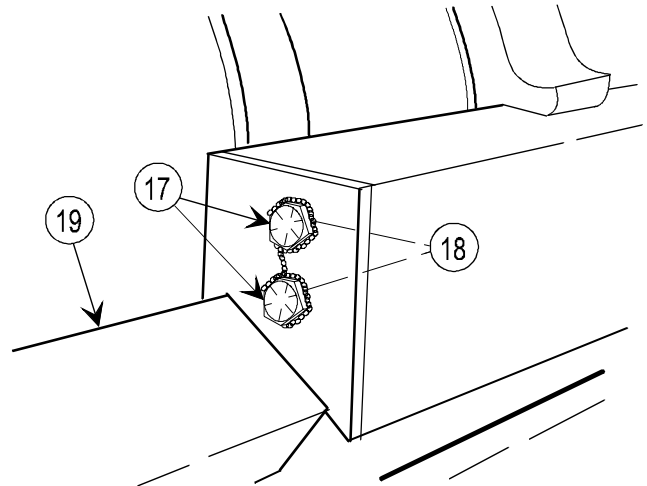

- 7** Remove two cap screws (17) and two lock washers (18) from cover (19).

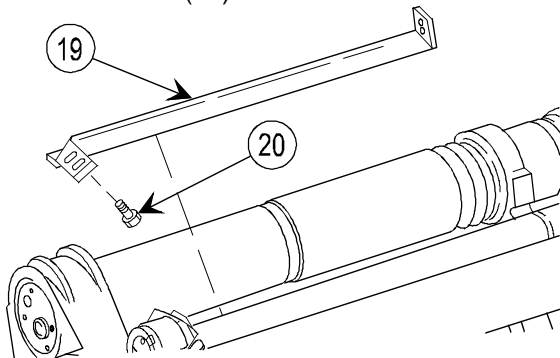

- 8** Remove lock wire and two cap screws (20) from cover (19).

- 9** Remove cover (19).

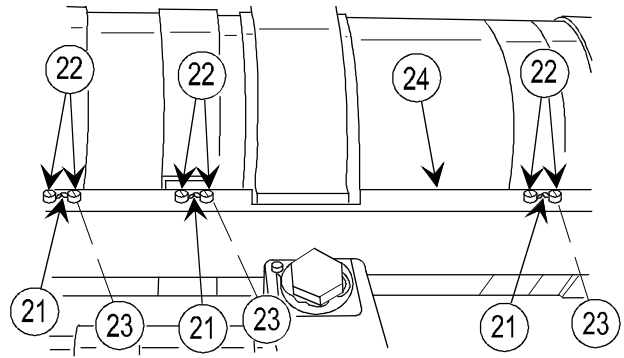

- 10** Remove lock wire (21), six machine screws (22), six lock washers (23), and cover (24).

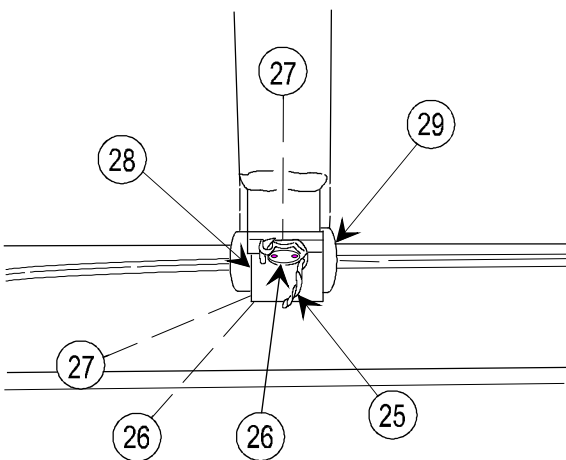

- 11** Remove lock wire (25), two cap screws (26), two lock washers (27), retaining strap (28), and rubber bushing (29).

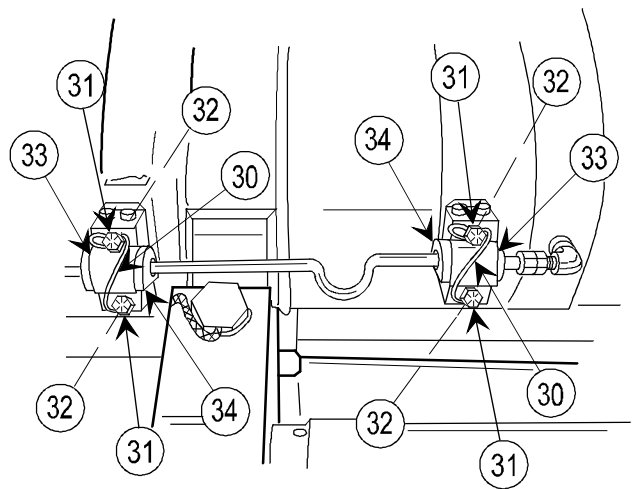

- 12** Remove lock wire (30), four cap screws (31), four lock washers (32), two retaining straps (33), and two rubber bushings (34).

2-14. RECUPERATOR CYLINDER ASSEMBLY AND PARTS—MAINTENANCE INSTRUCTIONS
(cont)

REMOVAL (cont)

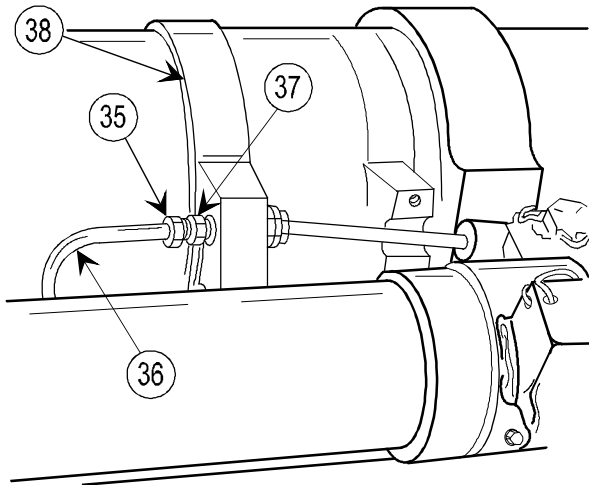

- 13 Loosen nut (35) and slide back over tube (36).
- 14 Remove tube (36) from adapter (37) and loop clamp assembly (38).
- 15 Remove adapter (37) only if damaged.

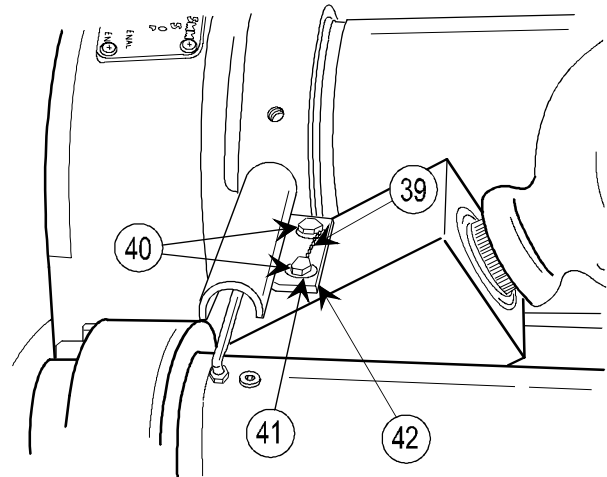

NOTE

Remove items in step 16 only for replacement.

- 16 Remove lock wire (39), two capscrews (40), two lockwashers (41), and retaining strap (42).

WARNING

Cover restrictor check valve with clean rag while cracking nuts (43). This will allow any pressure in lines to bleed off and reduce the possibility of injury to personnel.

- 17 Unscrew two nuts (43) from restrictor check valve (44) and elbow (45), then slide back on tube (46).
- 18 Remove tube (46).

NOTE

Steps 19 and 20 are not required if sleeves (47) are not damaged.

- 19 Remove two sleeves (47) from tube (46).
- 20 Remove two nuts (43).

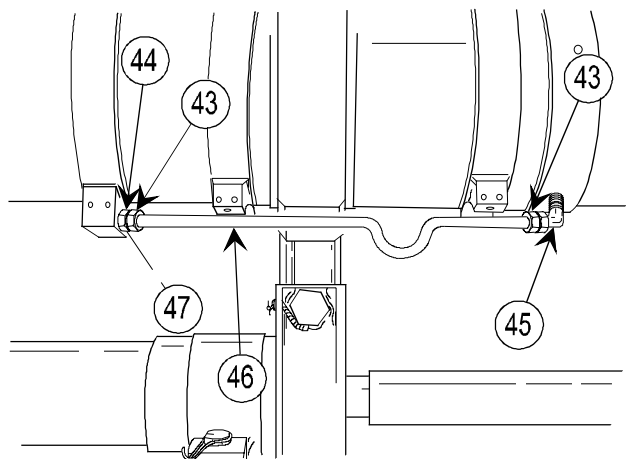

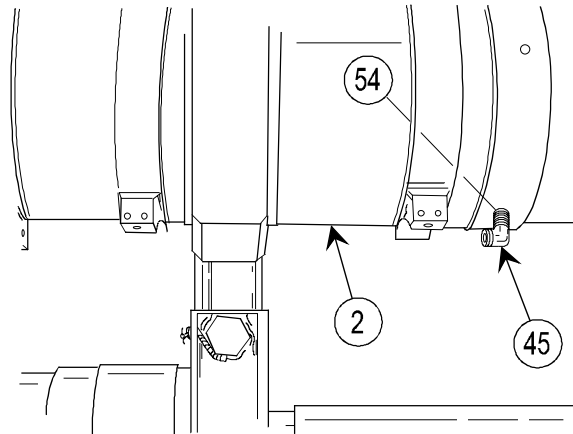
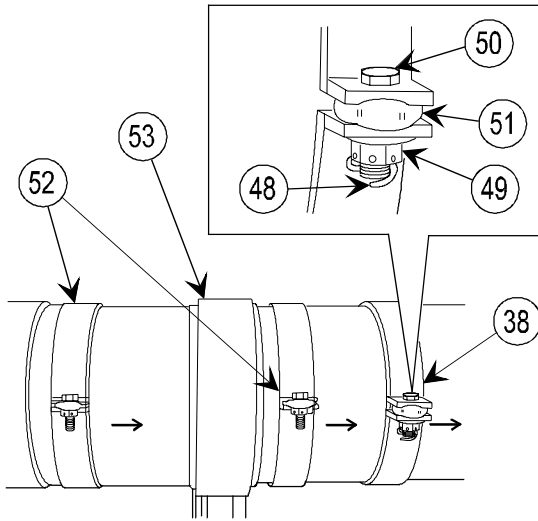

- 21 Remove four cotter pins (48), four nuts (49), four capscrews (50), and four rubber grommets (51) from three loop clamps (52) and loop clamp assembly (38).
- 22 Slide three loop clamps (52) and loop clamp assembly (38) from middle yoke (53) in direction of arrows.

- 23 Remove elbow (45) and preformed packing (54), and place clean rag over openings in recuperator cylinder assembly (2) and tube.

NOTE

Remove rigid connecting link (55) for replacement only; otherwise, disconnect at top only.

- 24 Remove two cotter pins (56) and two straight pins (57).
- 25 Remove rigid connecting link (55) from lever (58).

NOTE

Steps 26, 27, and 28 are not required to remove recuperator cylinder assembly (2).

- 26 Remove lock wire (59), setscrew (60), and nut (61).
- 27 Remove lever (58) from recuperator shaft (62).

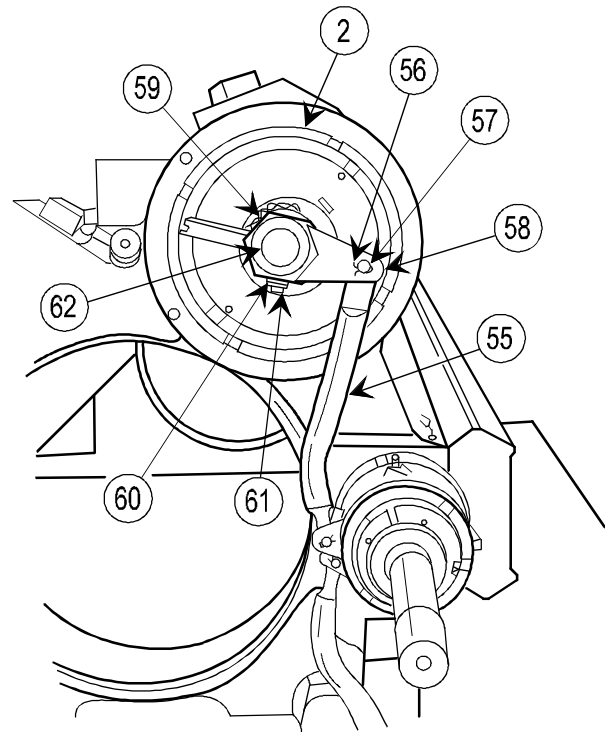

2-14. RECUPERATOR CYLINDER ASSEMBLY AND PARTS—MAINTENANCE INSTRUCTIONS (cont)

REMOVAL (cont)

- 28 Remove machine key (63) and shim (64) from recuperator shaft (62).
- 29 Remove lock wire (65) and two bolts (66) from front yoke.

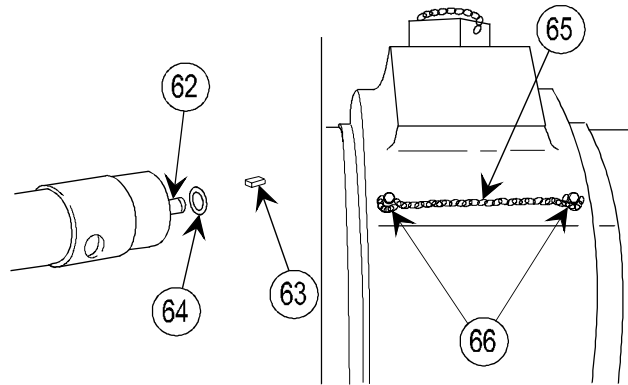

WARNING

For safety precautions, prior to beginning any painting operations, refer to TM 43-0139. Improper application or removal of CARC paint can be extremely hazardous to your health.

NOTE

Strip paint from recuperator cylinder assembly with paint stripper and abrasive cloth where recuperator cylinder assembly is thicker in diameter than remainder of recuperator cylinder assembly. This is around the front, middle, and rear yokes and around ring where setscrew and elbow are located. After paint is removed, clean entire recuperator cylinder assembly with cleaning compound to prevent contamination from dropping into the front yoke.

- 30 Unscrew tube flange nut (67) from elbow (68).
- 31 Loosen two retainer nuts (69).

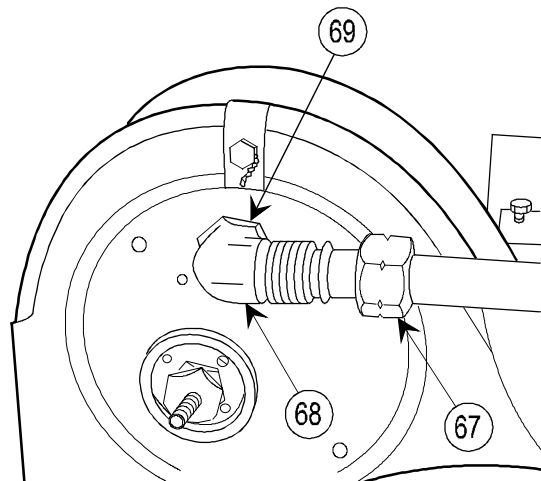

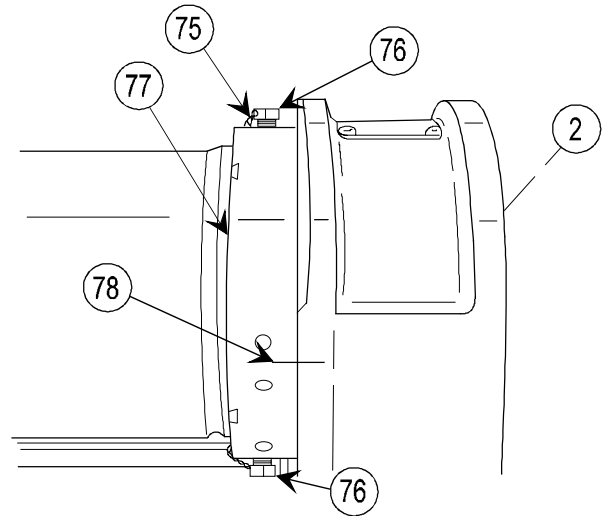
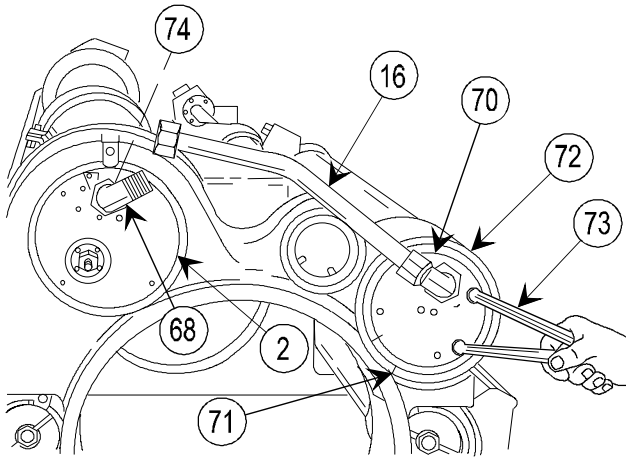

NOTE

Before rotating head (70), place a scribe mark (71) across head and air cylinder (72) for realinement later.

- 32 Using spanner wrench (73), rotate head (70) clockwise enough to separate tube (16) from elbow (68) at end of recuperator cylinder assembly (2).
- 33 Remove elbow (68) and preformed packing (74).

- 34 Place clean rag in opening of recuperator cylinder assembly (2).
- 35 Remove lock wire (75) and two setscrews (76) from nut (77).
- 36 Before loosening nut (77), scribe mark (78) to ring and rear yoke.

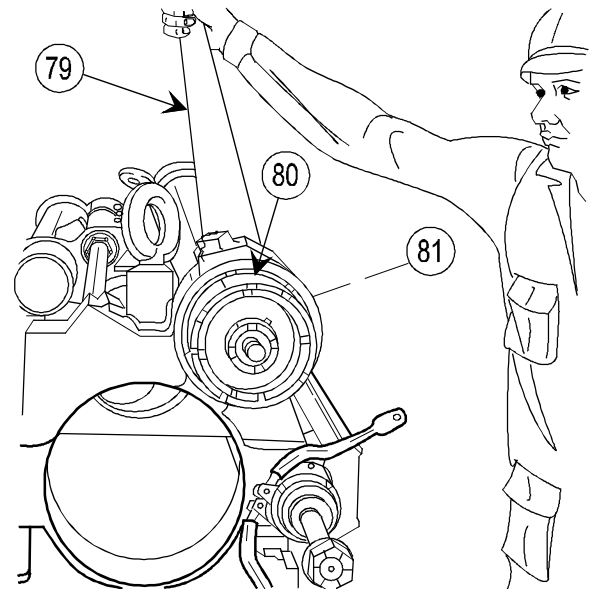
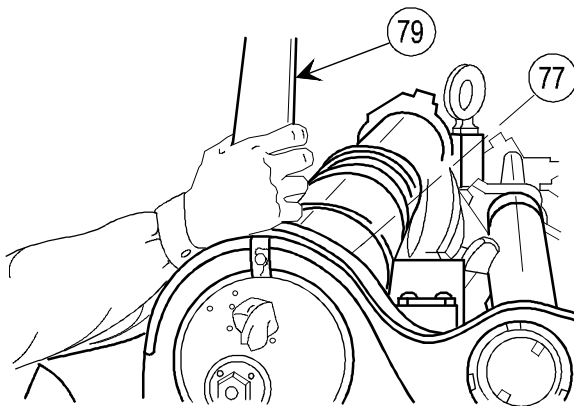

- 37 Loosen nut (77) one or two turns using spanner wrench (79).

- 38 Remove ring (80) using spanner wrench (79).

NOTE

Nut (77) must be removed after recuperator cylinder assembly is pulled out of rear yoke.

NOTE

Ring (81) will be removed when recuperator cylinder assembly is pulled out of middle yoke.

- 39 Loosen ring (81) using spanner wrench (79).

2-14. RECUPERATOR CYLINDER ASSEMBLY AND PARTS—MAINTENANCE INSTRUCTIONS (cont)

REMOVAL (cont)

CAUTION

Do not scratch the preformed packing mating surface and seats of the front yoke or recuperator cylinder assembly.

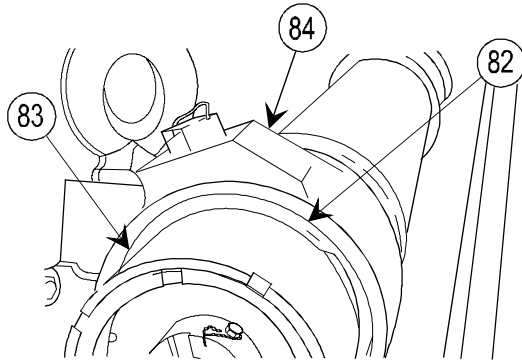

- 40** Use a scribe or other sharp tool to remove two preformed packings (82) and two ring spacers (83) from each side of front yoke (84).

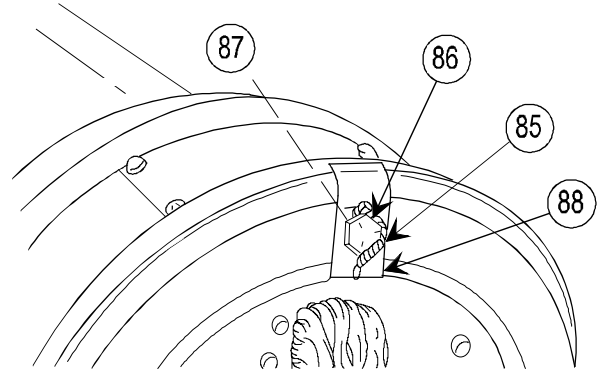

- 41** Remove lock wire (85), cap screw (86), lock washer (87), and restraint key (88).

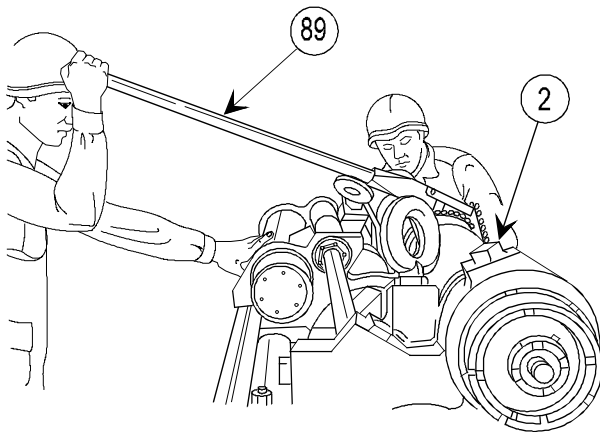

- 42** Turn recuperator cylinder assembly (2) counter-clockwise 1/8 turn with tube wrench (89).

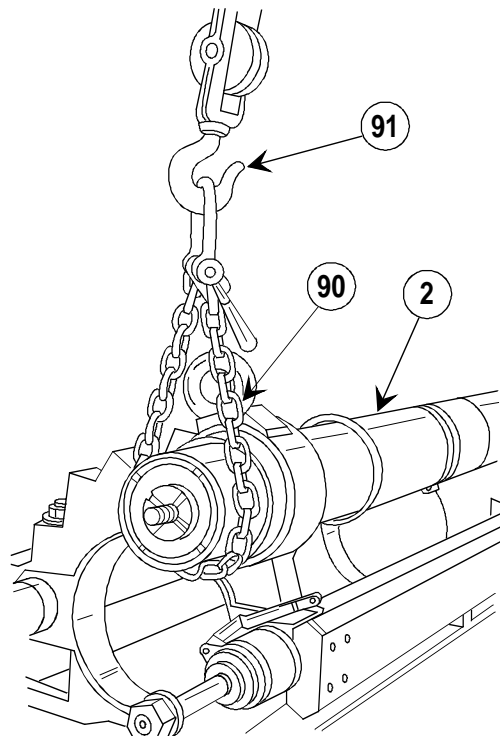

- 43** Slide recuperator cylinder assembly (2) forward approximately 6 in. (15 cm), using sling (90) and 3-ton hoist (91).

- 44** Drain oil into a 2- to 3-gal. (8- to 11-liter) container.

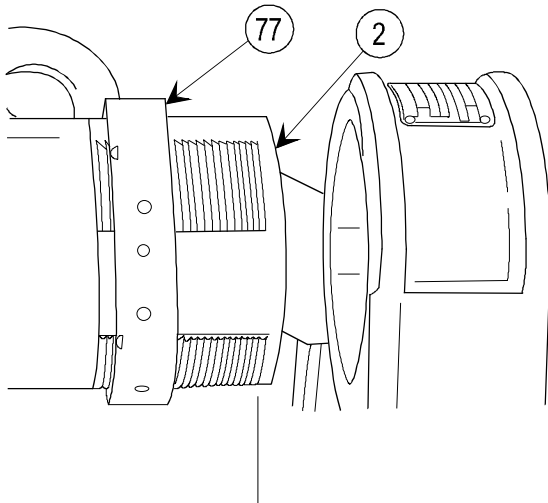

- 45 Remove nut (77) from reciperator cylinder assembly (2).

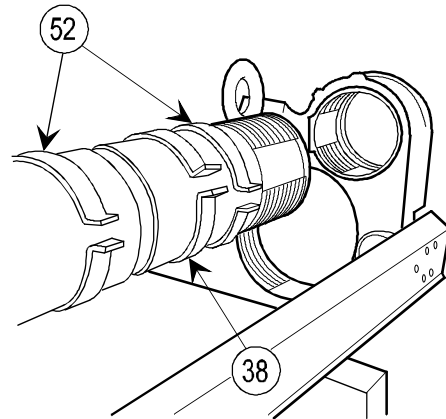

- 46 Remove two loop clamps (52) and loop clamp assembly (38).

CAUTION

Do not scrape front yoke when removing reciperator cylinder assembly, allowing paint scrapings to drop into front yoke.

NOTE

Use of fabricated tool (figure C-23, appx C) provides protection against contamination of front yoke with paint scrapings.

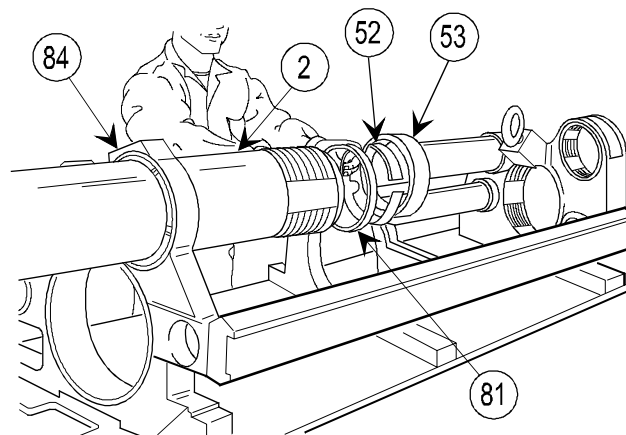

- 47 Move reciperator cylinder assembly (2) forward past middle yoke (53), removing one loop clamp (52) and ring (81).

NOTE

Remove rag from reciperator cylinder assembly opening before removing reciperator cylinder.

- 48 Continue moving reciperator cylinder assembly (2) forward through front yoke (84), and remove. With reciperator assembly supported by a 3-ton hoist, clean threads with cleaning compound and lubricate with WTR grease.

2-14. RECUPERATOR CYLINDER ASSEMBLY AND PARTS—MAINTENANCE INSTRUCTIONS (cont)

REMOVAL (cont)

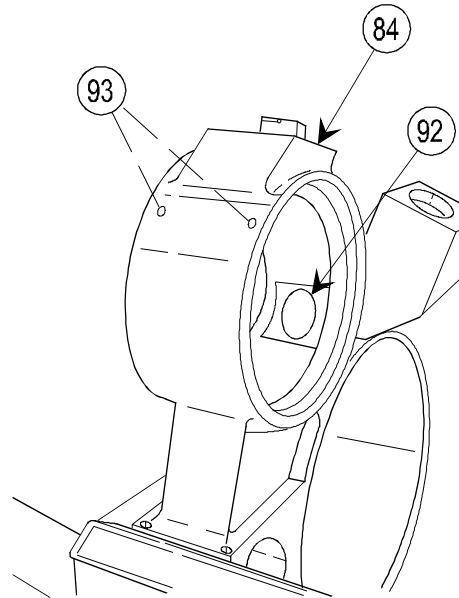

NOTE

Cover openings (92) in front yoke (84) with wiping rags to prevent losing plastic pellets (93), and cover front yoke with clean wiping rag until recuperator cylinder assembly is installed.

- 49 Remove two plastic pellets (93) from front yoke (84).
- 50 Clean threads on yokes with cleaning compound and lubricate with WTR grease.

2-14. RECUPERATOR CYLINDER ASSEMBLY AND PARTS—MAINTENANCE INSTRUCTIONS (cont)

DISASSEMBLY

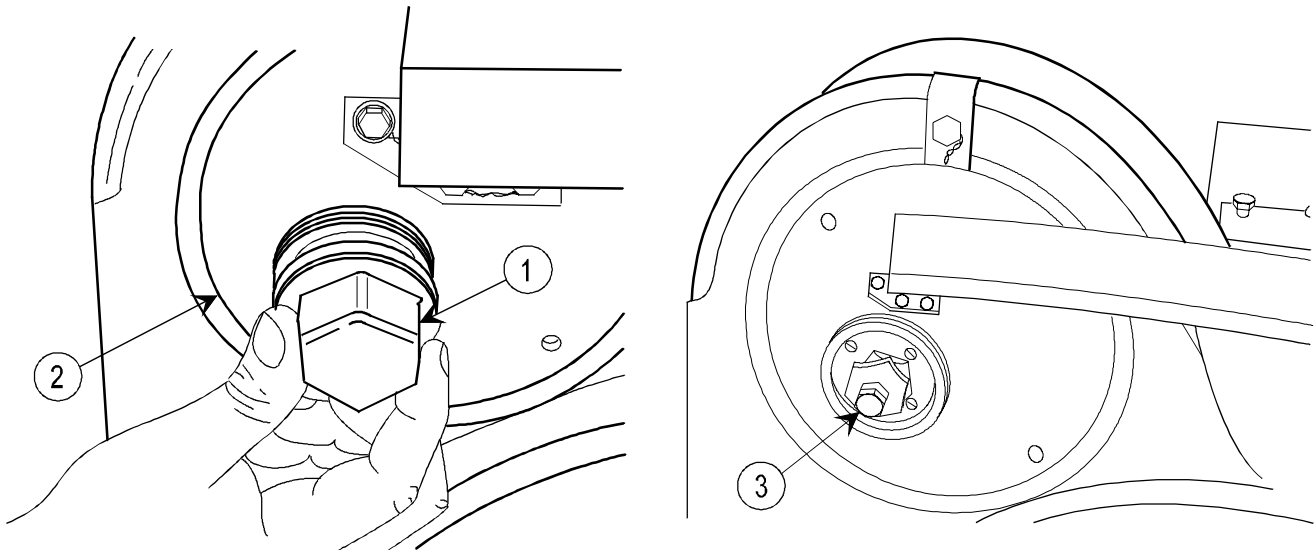

NOTE

This task may be done with the recuperator cylinder assembly on or off weapon. If done on weapon, M199 cannon must be leveled before starting task (TM 9-1025-211-10). If recuperator is removed from recoil assembly, the nitrogen pressure is already bled from recuperator. Proceed to step 4.

- 1 Unscrew and remove cap (1) from recuperator cylinder assembly (2).
- 2 Unscrew and remove valve cap (3).
- 3 Slightly loosen or unscrew valve nut (4) on check valve (5) until valve nut becomes tight; then open slowly to bleed all nitrogen pressure.

WARNING

Failure to bleed off all nitrogen pressure in the recuperator cylinder assembly could lead to severe injury.

- 4 Remove two self-locking screws (6) from valve assembly lock (7).
- 5 Remove valve assembly lock (7).
- 6 Unscrew and remove check valve (5).

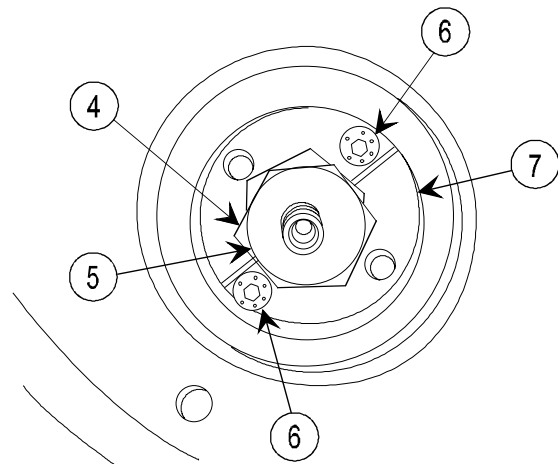

INSPECTION/REPAIR

- 1 Check for broken, damaged, or missing parts.
- 2 Repair is by replacement of authorized parts (TM 9-1025-211-34P).

REASSEMBLY

- 1 Install and tighten check valve (1) securely.
- 2 Install valve assembly lock (2) over check valve (1).
- 3 Aline two of the four holes with two holes of the recuperator cylinder assembly (3).

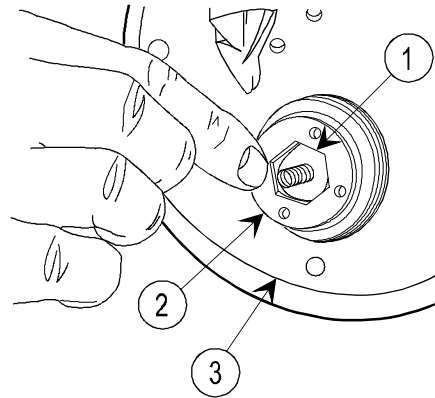

- 4 Install two self-locking screws (4) and tighten.

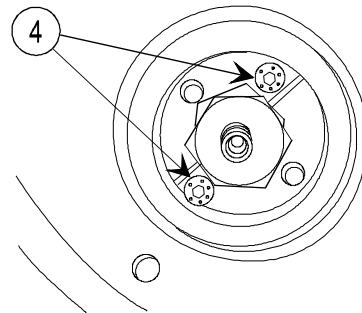

NOTE

Charge recoil mechanism with nitrogen (p 2-58) if recuperator is installed in recoil mechanism. Otherwise, complete installation of recuperator.

- 5 Install cap (5).

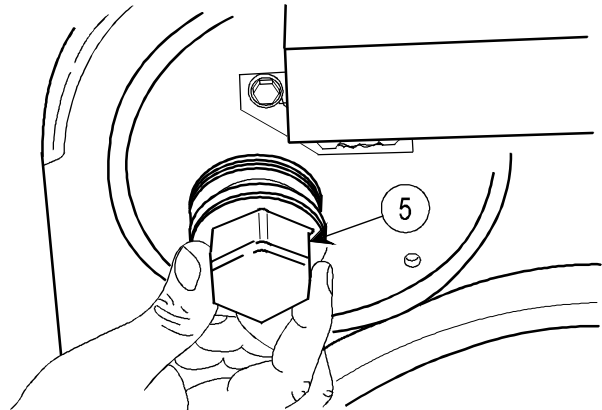

INSTALLATION

NOTE

When installing recuperator cylinder assembly, ensure that recuperator cylinder assembly does not scrape front yoke, allowing paint scrapings to drop into front yoke. Remove any wiping rag from yokes. Use of fabricated tool (figure C-23, appx C) provides protection against contamination of front yoke with paint scrapings.

- 1 Insert threaded end of recuperator cylinder assembly (1) through front yoke (2) approximately 12 to 14 in. (30 to 35 cm), using sling (3) and 3-ton hoist (4).

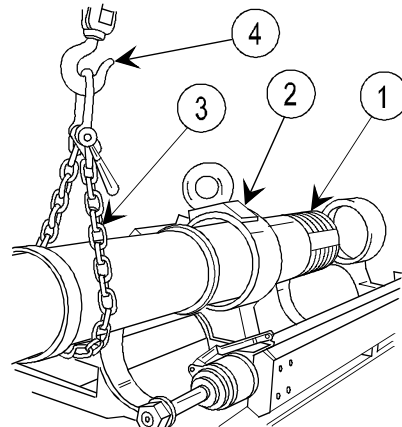

2-14. RECUPERATOR CYLINDER ASSEMBLY AND PARTS—MAINTENANCE INSTRUCTIONS (cont)

INSTALLATION (cont)

- 2 Lubricate new preformed packing (5) with grease and new ring spacer (6) and install at rear of front yoke (2).
- 3 Install ring (7) with wrench slots facing rear of recuperator cylinder assembly (1).
- 4 Install loop clamp (8).
- 5 Move recuperator cylinder assembly (1) through middle yoke (9) while keeping preformed packing (5), ring spacer (6), and ring (7) immediately behind front yoke (2).
- 6 Install remaining loop clamps (8) and loop clamp assembly (10).

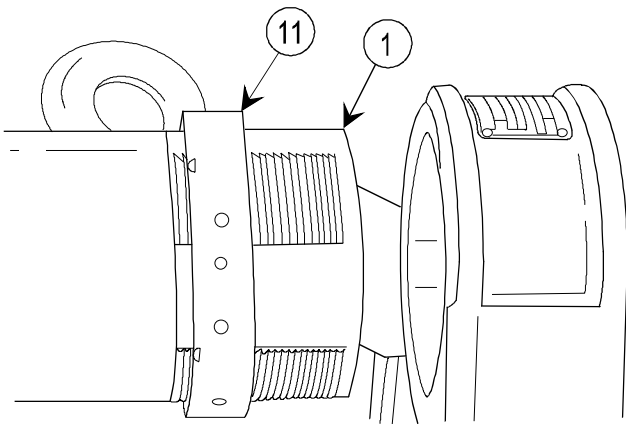
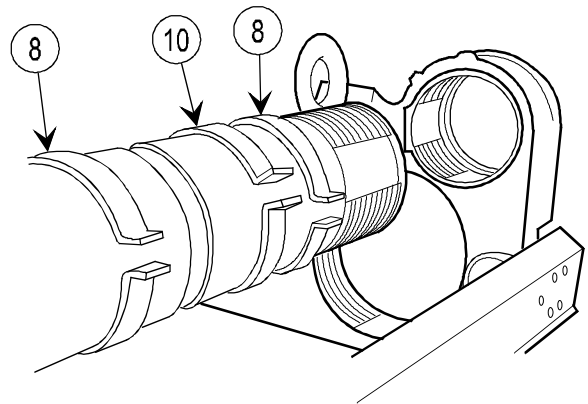
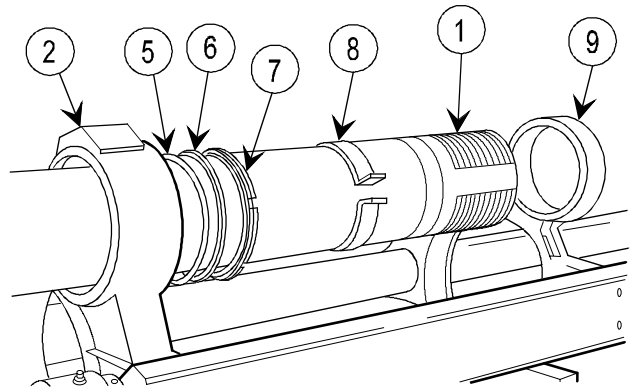

NOTE

Make sure wrench slots of nut (11) are facing toward front of recuperator cylinder assembly (1).

- 7 Assemble nut (11) on recuperator cylinder assembly (1), and position to front of threaded end. Apply WTR grease to threads of rear yoke and recuperator assembly.

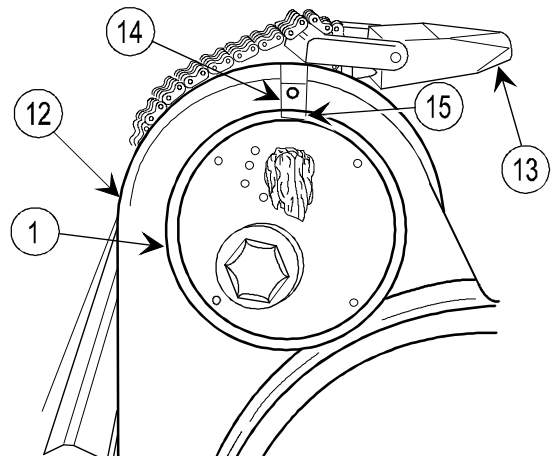

- 8 Move recuperator cylinder assembly (1) into rear yoke (12).
- 9 Turn 1/8 turn with tube wrench (13), and align key slot (14) at rear of rear yoke with key slot (15) in end of recuperator cylinder assembly (1). (End of recuperator cylinder assembly (1) and rear yoke (12) should be flush.)

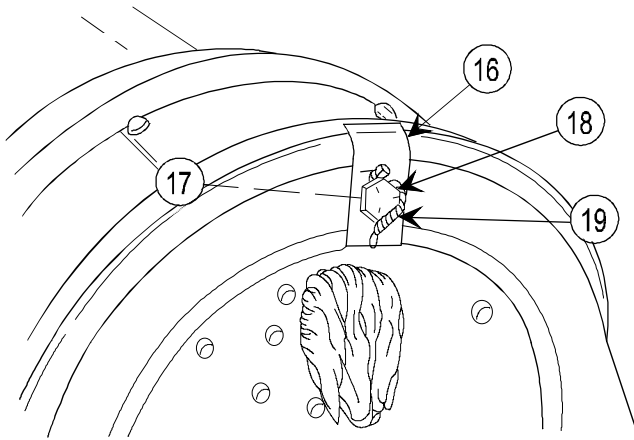

- 10 Install restraint key (16), lockwasher (17), cap-screw (18), and lock wire (19).

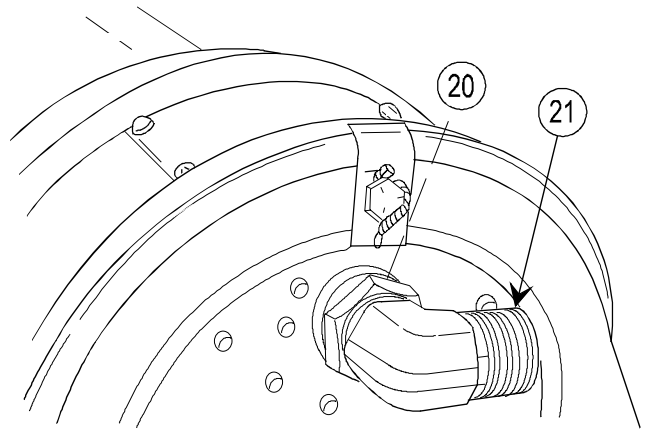

- 11 Remove rag from hole. Install new preformed packing (20) and elbow (21).

CAUTION

When installing preformed packings, do not scratch or cut them. (This causes leaks.) Assemble and seat them into place by first pushing in bottom, then top, and then side to side, using fabricated tool. It is important that they seat completely without stretching so they will not be cut when nuts are installed.

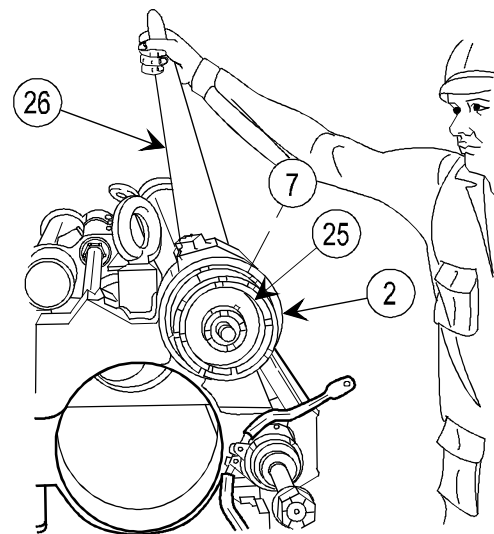
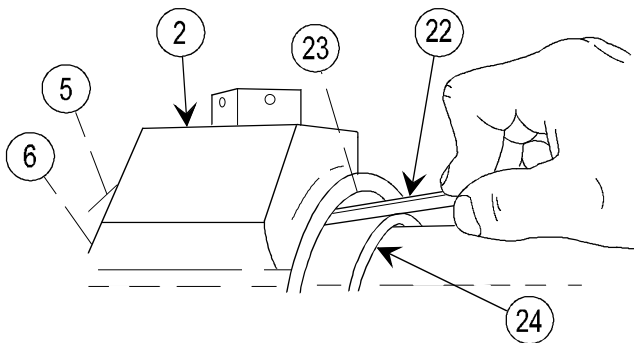

- 12 Using fabricated tool (22), position new preformed packing (23) and new ring spacer (24) in front of front yoke (2).
- 13 Using fabricated tool (22), position new preformed packing (5) and new ring spacer (6) in rear of front yoke (2).
- 14 Lightly coat ring (25) with WTR grease, assemble, and loosely screw into front yoke (2).
- 15 Tighten ring (25) using spanner wrench (26); and then back off 1/8 to 1/4 turn.
- 16 Lightly coat ring (7) with WTR grease and screw into rear of front yoke (2).
- 17 Tighten ring (7) using spanner wrench (26); and then back off 1/8 to 1/4 turn.

2-14. RECUPERATOR CYLINDER ASSEMBLY AND PARTS—MAINTENANCE INSTRUCTIONS
 (cont)

INSTALLATION (cont)

- 18** Tighten nut (11) against rear yoke until setscrew holes in nut (11) align with holes previously drilled in recuperator cylinder assembly or scribe lines (27) align.

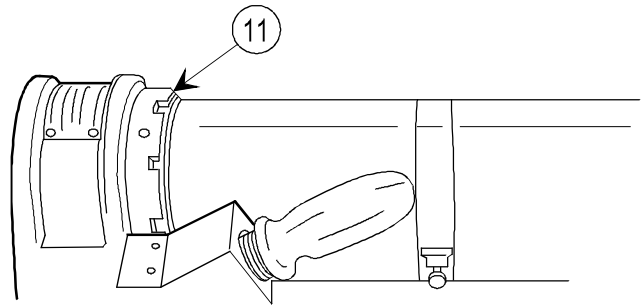

NOTE

If new recuperator cylinder assembly is installed, tighten nut (11) until scribe lines (27) are aligned. Then drill 0.18-in. (0.46-cm) diameter hole 0.07 in. (0.18 cm) deep in recuperator cylinder assembly to accept cup point.

- 19** Install two setscrews (28) and lock wire (29) in nut (11).

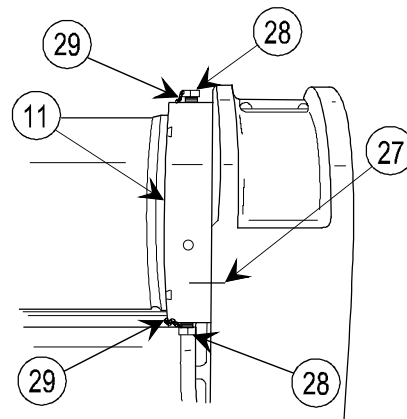

NOTE

Scribe line placed on head (30) of air cylinder assembly during removal should be aligned for installation.

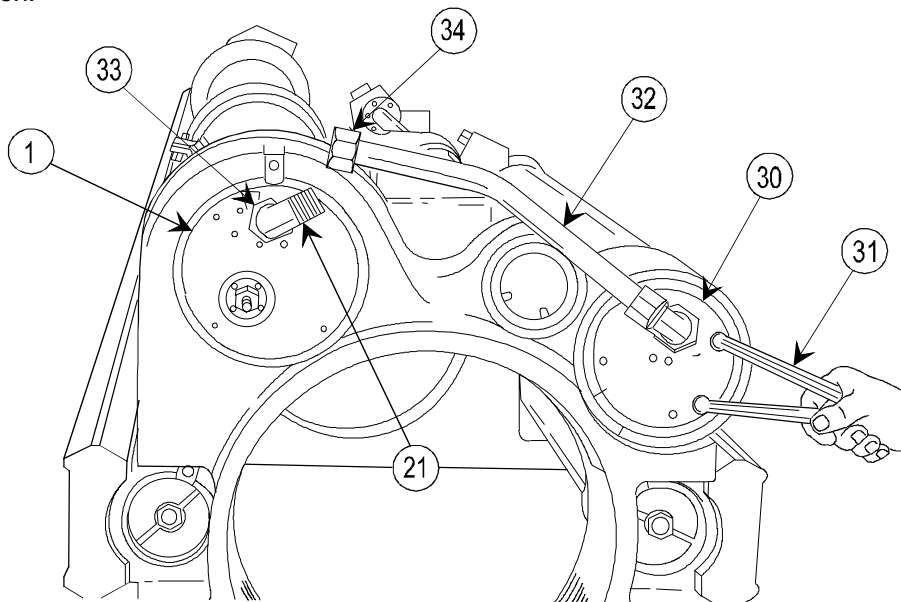

- 20** Using spanner wrench (31), rotate head (30) counterclockwise enough to align tube (32) with elbow (21) at end of recuperator cylinder assembly (1).

- 21** Tighten two retainer nuts (33).
22 Install tube flange nut (34) and tighten.

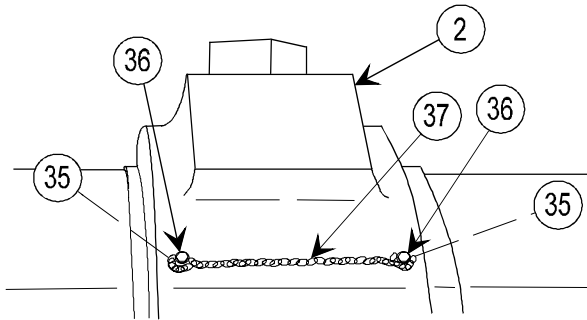

23 Install two new plastic pellets (35), two bolts (36), and lock wire (37) in front yoke (2).

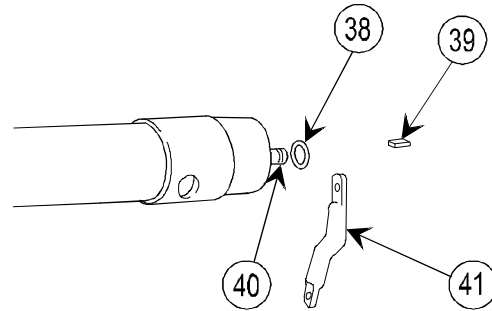

24 Install shim (38) and machine key (39) on recuperator shaft (40), and adjust thickness of shim to prevent binding of rigid connecting link (41).

25 Install lever (42), nut (43), setscrew (44), and lock wire (45).

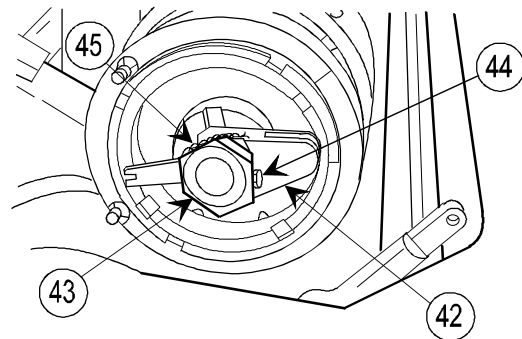

26 Connect rigid connecting link (41) to lever (42).

NOTE

Install straight pins (46) with heads toward breech end.

27 Install two straight pins (46) and two new cotter pins (47).

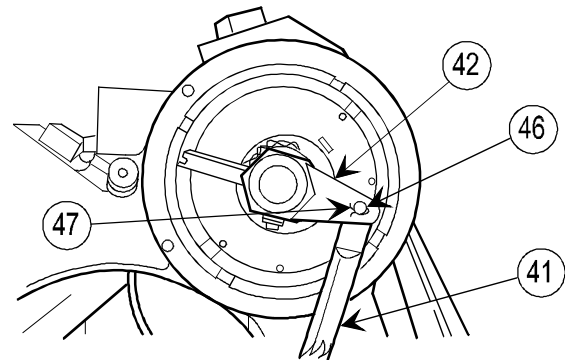

28 If removed, install two nuts (48) on tube (49).

29 If removed, install two sleeves (50) on tube (49).

30 Install new preformed packing (51) and elbow (52).

31 Install tube (49) in elbow (52) and restrictor check valve (53).

32 Screw two nuts (48) onto elbow (52) and restrictor check valve (53), and tighten.

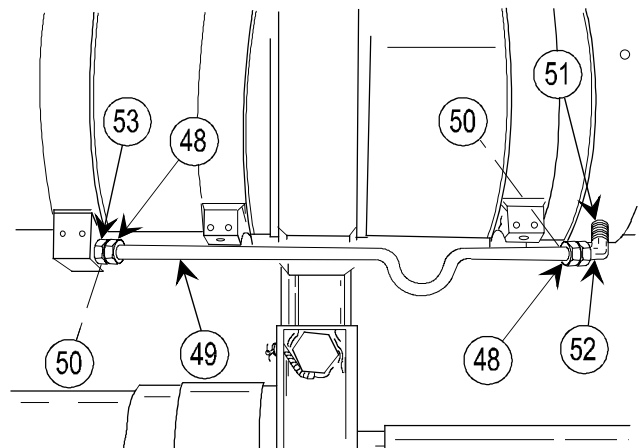

2-14. RECUPERATOR CYLINDER ASSEMBLY AND PARTS—MAINTENANCE INSTRUCTIONS (cont)

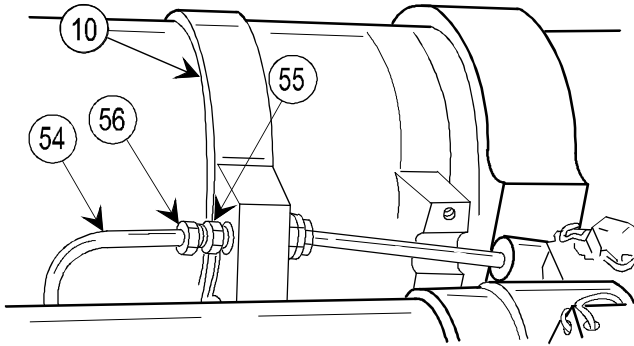

33 Install tube (54) on adapter (55) and loop clamp assembly (10).

34 Slide nut (56) over tube (54) and tighten.

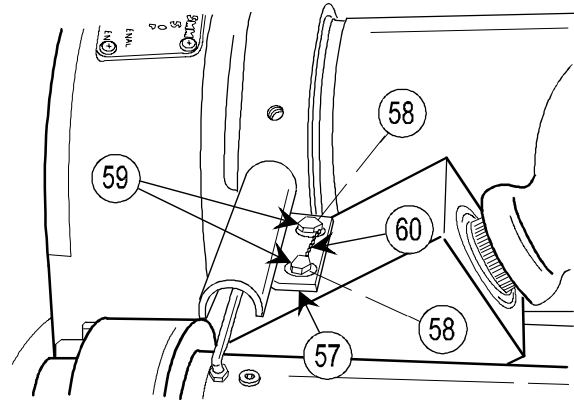

35 Install retaining strap (57), two lockwashers (58), two capscrews (59), and lock wire (60).

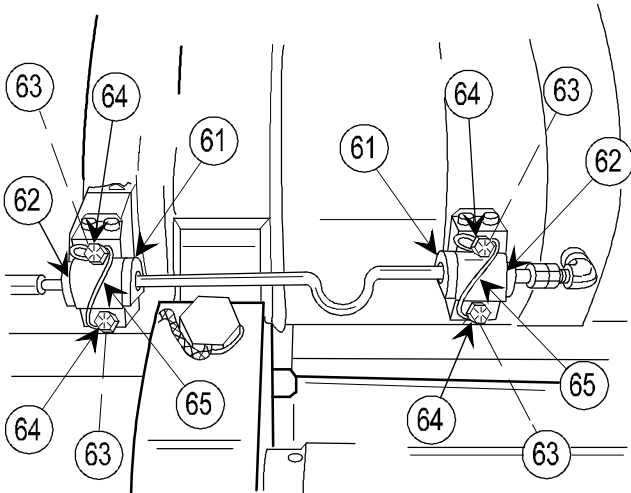

36 Install two rubber bushings (61), two retaining straps (62), four lockwashers (63), four capscrews (64), and lock wire (65).

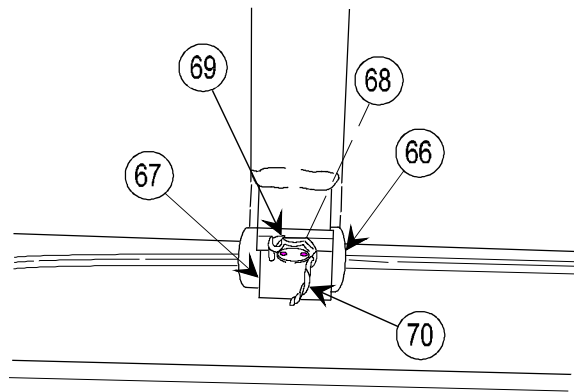

37 Install rubber bushing (66), retaining strap (67), two lockwashers (68), two capscrews (69), and lock wire (70).

38 Install four rubber grommets (71), four capscrews (72), four nuts (73), and four new cotter pins (74) in loop clamps (8) and loop clamp assembly (10).

NOTE

Check all fittings or components for hydraulic leaks or nitrogen leaks prior to cover installation.

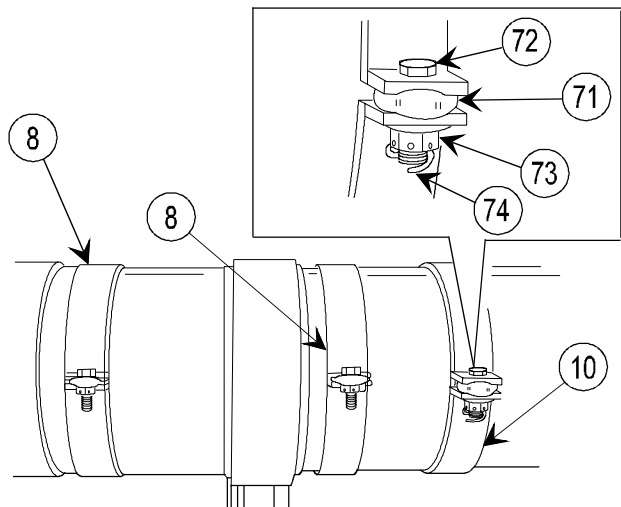

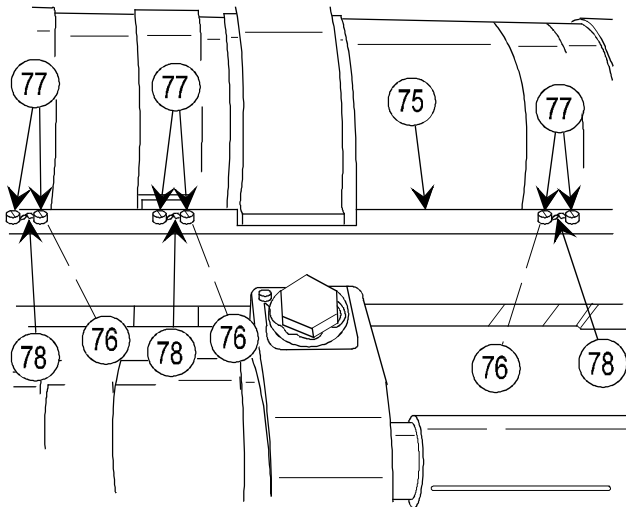

- 39 Install cover (75).
- 40 Install six lockwashers (76), six machine screws (77), and lock wire (78).

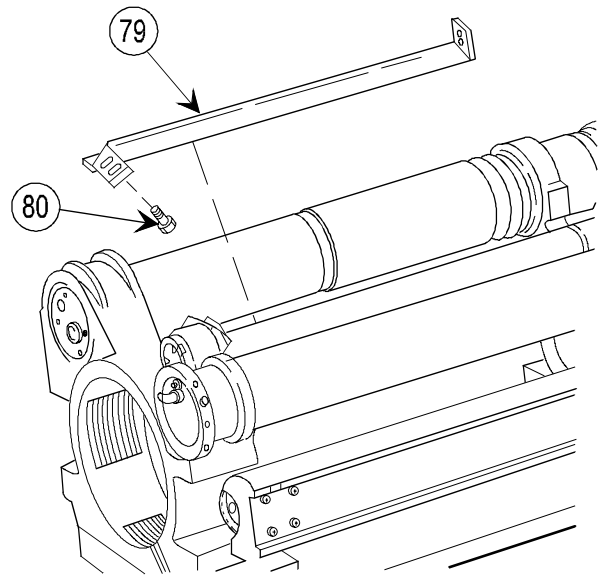

- 41 Install cover (79).
- 42 Install two capscrews (80) and lock wire.

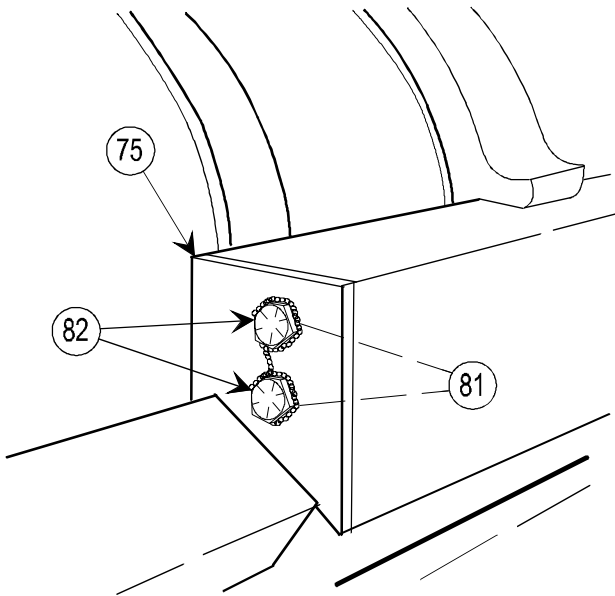

- 43 Install two lockwashers (81) and two capscrews (82) in cover (75). Lock wire capscrews (82).

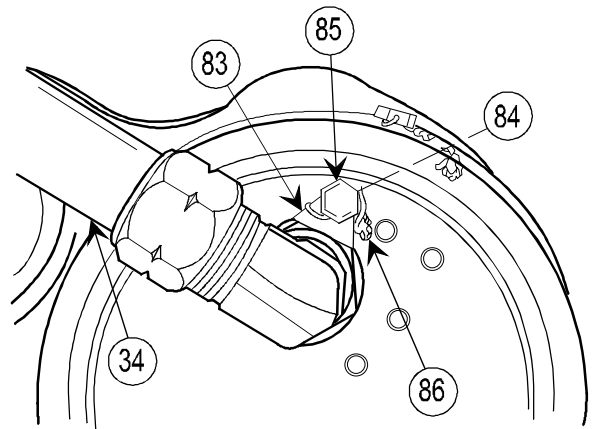

- 44 Install two stops (83), two lockwashers (84), two capscrews (85), and lock wire (86) at both ends of tube (34).

2-14. RECUPERATOR CYLINDER ASSEMBLY AND PARTS—MAINTENANCE INSTRUCTIONS (cont)

INSTALLATION (cont)

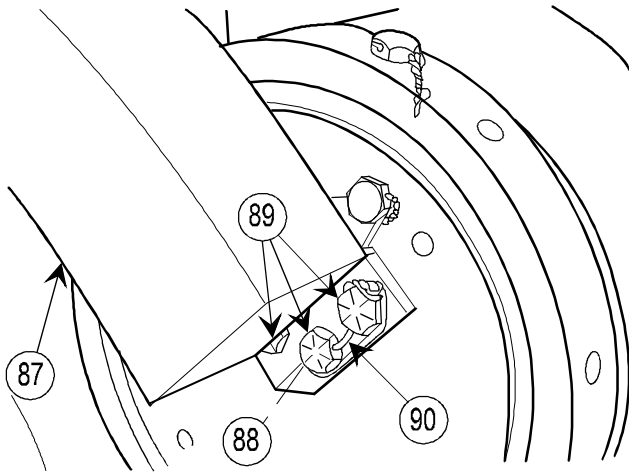

- 45** Install cover (87), three lockwashers (88), three cap screws (89), and lock wire (90).

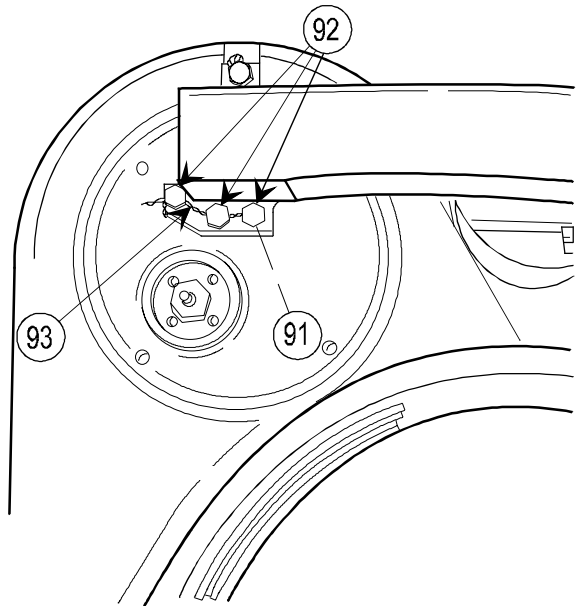

- 46** Install three lockwashers (91), three cap screws (92), and lock wire (93).

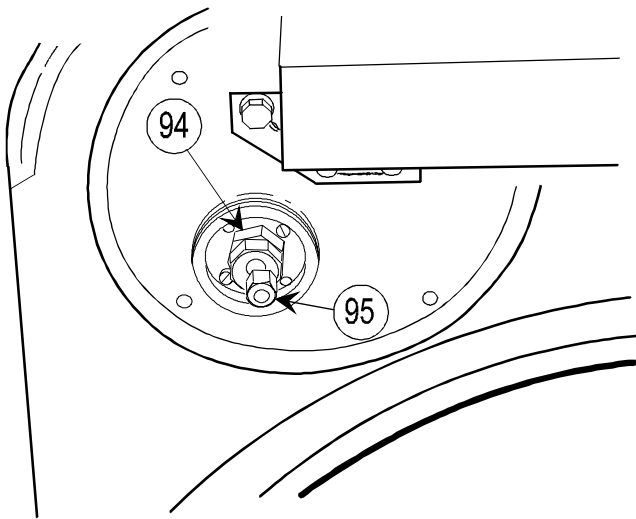

- 47** Tighten nut on check valve (94).
48 Install valve cap (95).

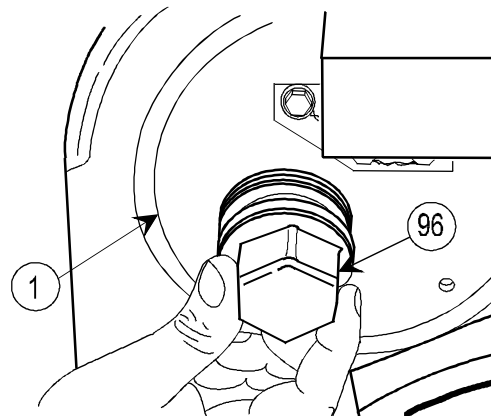

NOTE

Charge system (p 2-58), and check for leaks (p 2-58).

- 49** Install cap (96) on recuperator cylinder assembly (1).

2-15. AIR CYLINDER ASSEMBLY—MAINTENANCE INSTRUCTIONS (cont)

REMOVAL (cont)

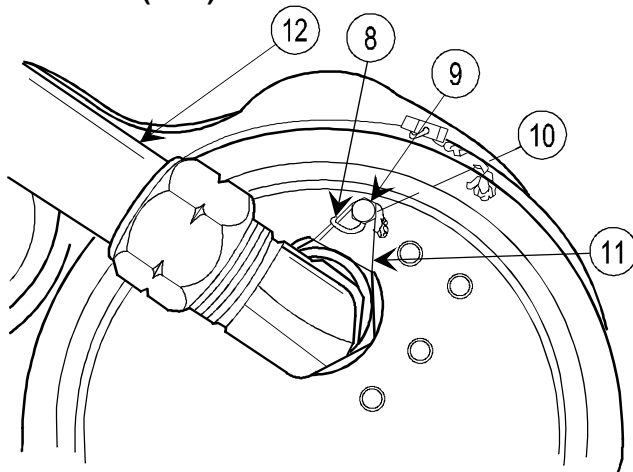

3 Remove lock wire (8), two capscrews (9), two lockwashers (10), and two stops (11) from each end of tube (12).

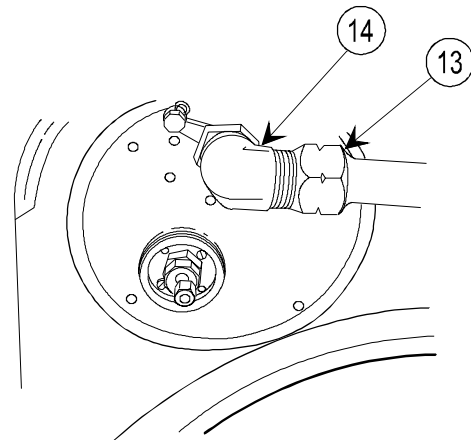

4 Unscrew tube flange nut (13) from elbow (14).

5 Loosen retainer nut (15) from recuperator cylinder assembly side.

NOTE

Before rotating head (16), place a scribe mark across it and air cylinder assembly (17) for realinement later.

6 Using spanner wrench (18), rotate head (16) clockwise enough to separate tube (12) from elbow (14) on recuperator cylinder assembly (19).

7 Place clean rag in open end of elbow (14) on recuperator cylinder assembly (19).

8 Remove tube (12) from elbow (14) at air cylinder assembly (17) only if tube is damaged.

9 Remove elbow (14), preformed packing (20), and retainer nut (21) from head (16), and place clean rag in opening in air cylinder assembly (17).

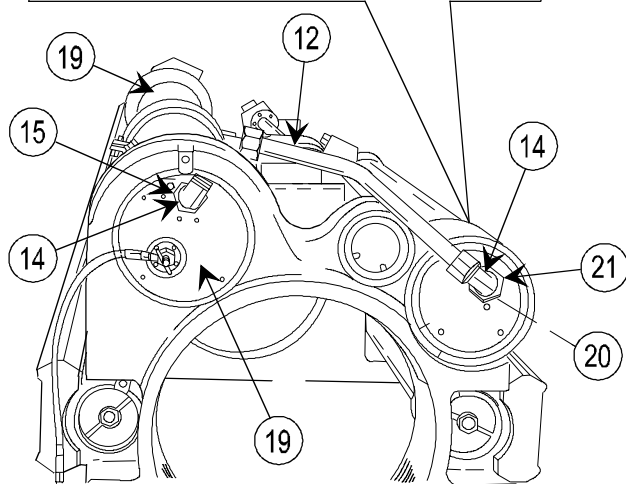
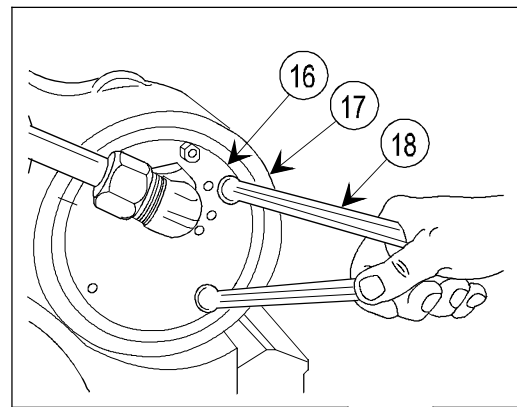

- 10 Remove lock wire (22) and setscrew (23) from nut (24).
- 11 Unscrew nut (24) and remove.

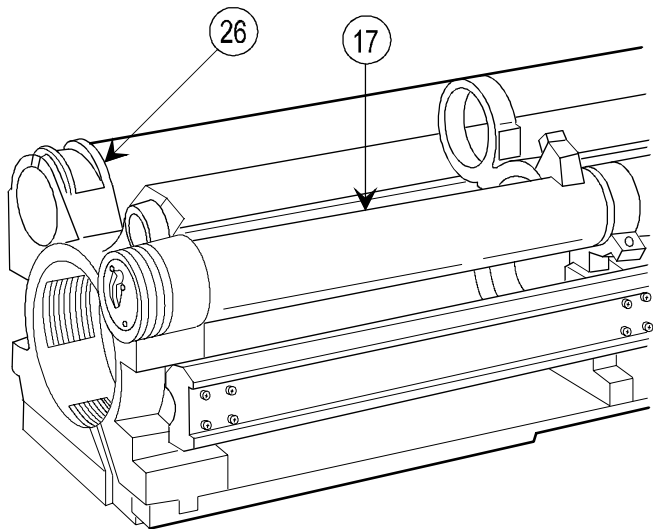
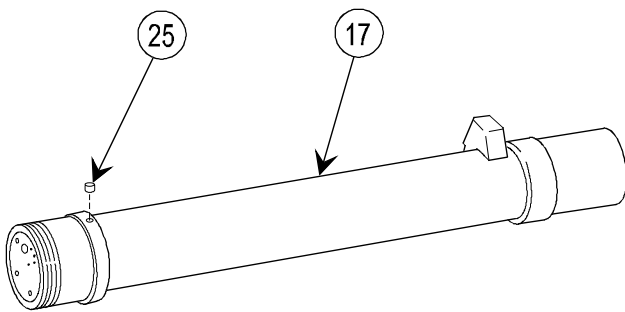
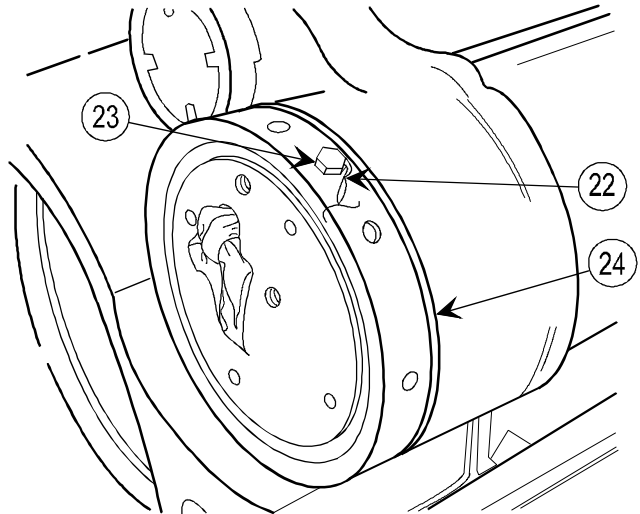

NOTE

Be careful not to lose machine key (25) when removing air cylinder assembly (17).

- 12 Slide air cylinder assembly (17) forward until clear of rear yoke (26), and remove.
- 13 Remove machine key (25).

INSPECTION/REPAIR

- 1 Check for broken, missing, or damaged parts.
- 2 Repair is by replacement of authorized parts (TM 9-1025-211-34P).
- 3 If nitrogen leaks between air cylinder assembly and head, replace air cylinder assembly.

2-15. AIR CYLINDER ASSEMBLY—MAINTENANCE INSTRUCTIONS (cont)

INSTALLATION

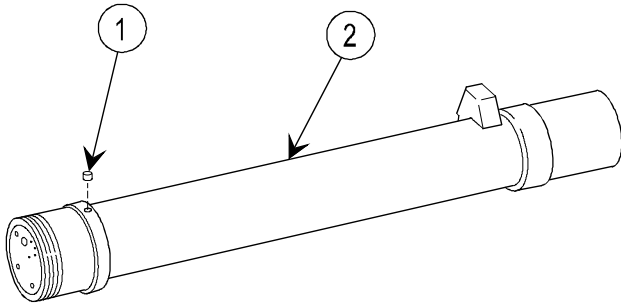

- 1** Install machine key (1) in air cylinder assembly (2).

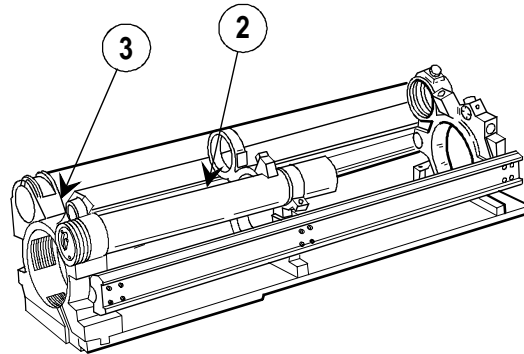

- 2** Install air cylinder assembly (2) by sliding threaded end into opening in rear yoke (3).

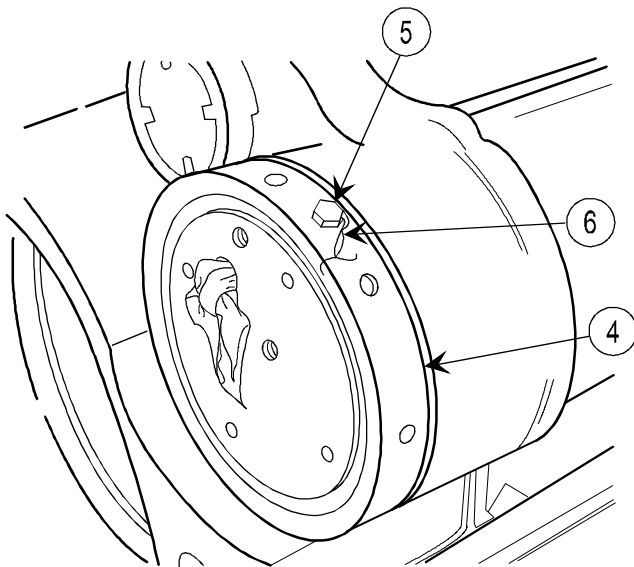

- 3** Install and tighten nut (4).

NOTE

If air cylinder assembly (2) was replaced, drill pilot hole 0.18 in. (0.46 cm) in diameter and 0.04 in. (0.10 cm) deep to accept point of setscrew (5). This operation can be done after charging and checking for nitrogen leaks.

- 4** Install setscrew (5) and lock wire (6).

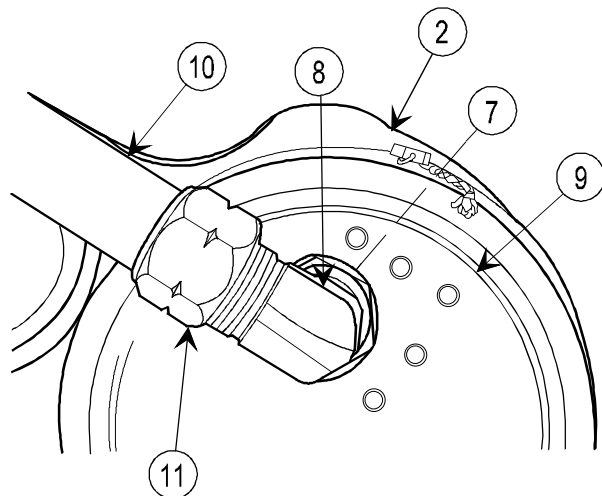

- 5** Slide new preformed packing (7) on elbow (8).
- 6** After removing rag, install elbow (8) in head (9), but do not tighten.
- 7** If removed, install tube (10) in elbow (8) on air cylinder assembly (2), but do not tighten tube flange nut (11).

NOTE

Scribe mark across end of air cylinder assembly (2) and head (12) should be aligned if old air cylinder assembly (2) was installed. Remove rag from elbow (8) on recuperator cylinder assembly (13).

- 8 Using spanner wrench (14), rotate head (12) and elbow (8) until tube (10) can be inserted in elbow (8) on recuperator cylinder assembly (13).
- 9 Tighten retainer nut (15) on each side.
- 10 Screw one tube flange nut (16) on elbow (8), and tighten tube flange nuts (11 and 16).
- 11 Install stop (17), lockwasher (18), capscrew (19), and lock wire (20) on each end of tube (10).

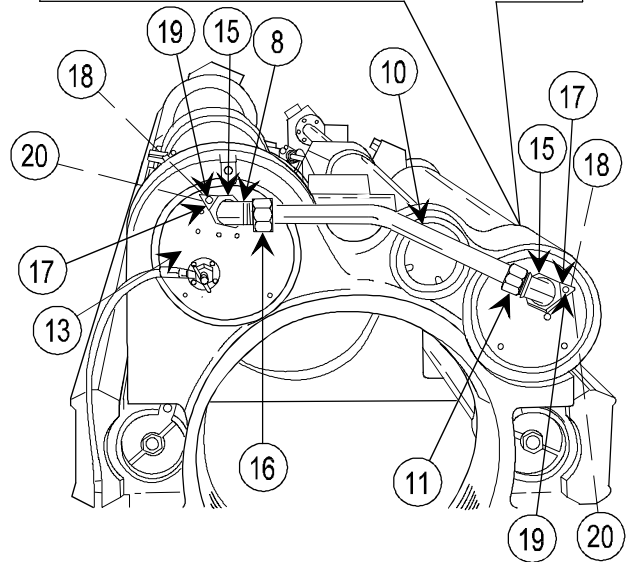
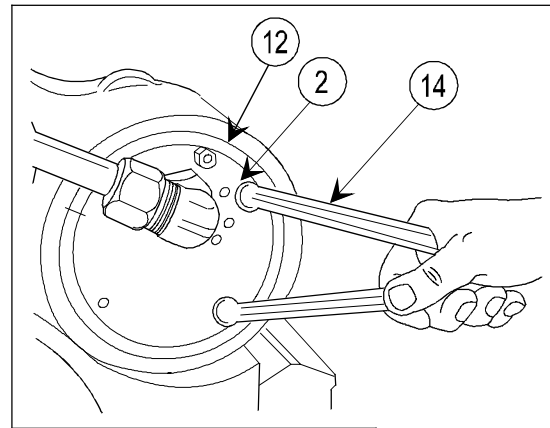

NOTE

Before replacing cover (21), charge system with nitrogen, and check for leaks (p 2-151).

- 12 Install cover (21), three lockwashers (22), three capscrews (23), and lock wire (24).
- 13 Install three lockwashers (25), three capscrews (26), and lock wire (27) on cover (21).

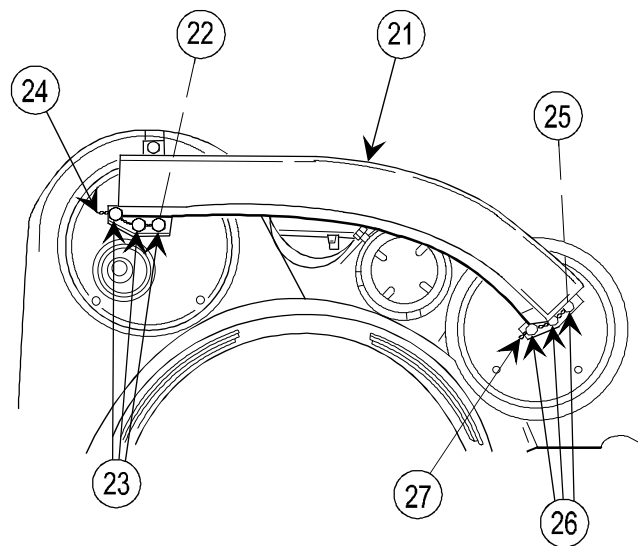

2-16. OIL VALVE ASSEMBLY—MAINTENANCE INSTRUCTIONS

THIS TASK COVERS:		
a. Removal	b. Inspection/repair	c. Installation
INITIAL SETUP		
Tools and Special Tools Artillery and turret mechanic's ordnance tool kit (SC 5180-95-CL-A12)		
Materials/Parts Gasket (7190924) Oil (hydraulic fluid) (item 14, appx B)		
References TM 9-1025-211-34P		
Equipment Conditions 2-58 Oil reserves drained		

REMOVAL

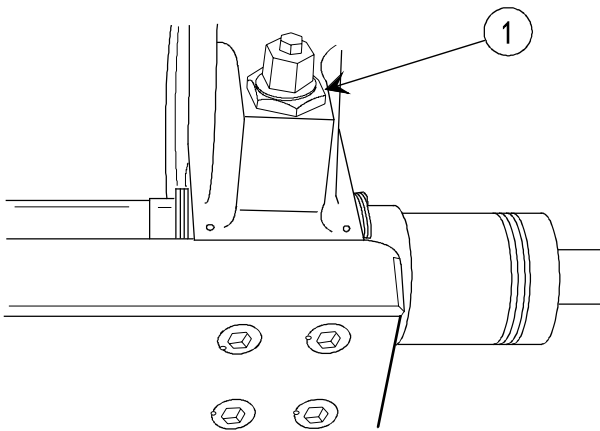

1 Remove nut (1).

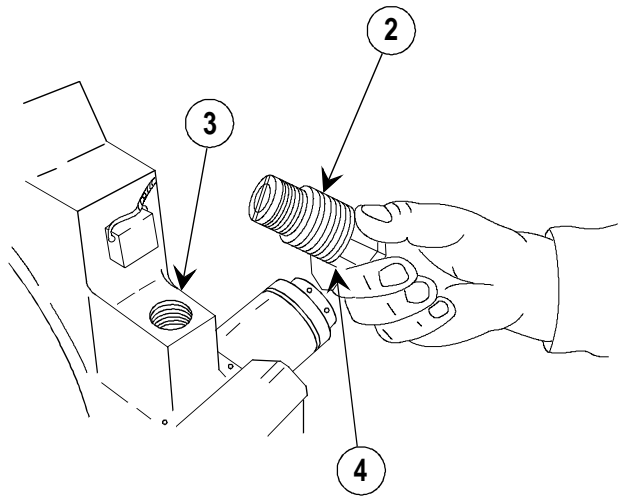

- 2 Remove oil valve assembly (2) from front yoke (3).
- 3 Remove plug (4) from oil valve assembly (2), if defective.

CAUTION

Gasket (5) can only be removed by prying it out. Be careful not to damage gasket seat.

- 4 Remove gasket (5) if defective.

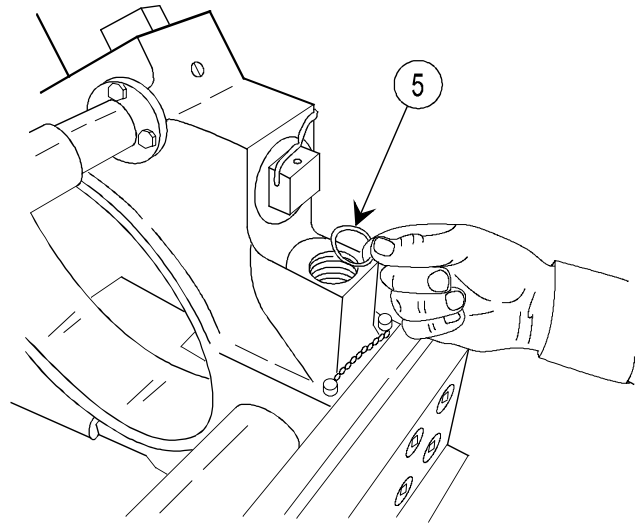

INSPECTION/REPAIR

- 1 Check for broken, missing, or damaged parts.
- 2 Repair is by replacement of authorized parts (TM 9-1025-211-34P).
- 3 Replace oil valve assembly if leaking or if threads are stripped beyond use.

INSTALLATION

NOTE

Valve well in front yoke (1) must be clean and filled with oil to gasket level (p 2-58).

- 1 Assemble new gasket (2) to oil valve assembly (3).
- 2 Install oil valve assembly (3) and tighten on front yoke (1).
- 3 Install nut (4) and tighten on oil valve assembly (3). Refill, and purge recoil mechanism (p 2-58) if required.
- 4 Install plug (5) on oil valve assembly (3).

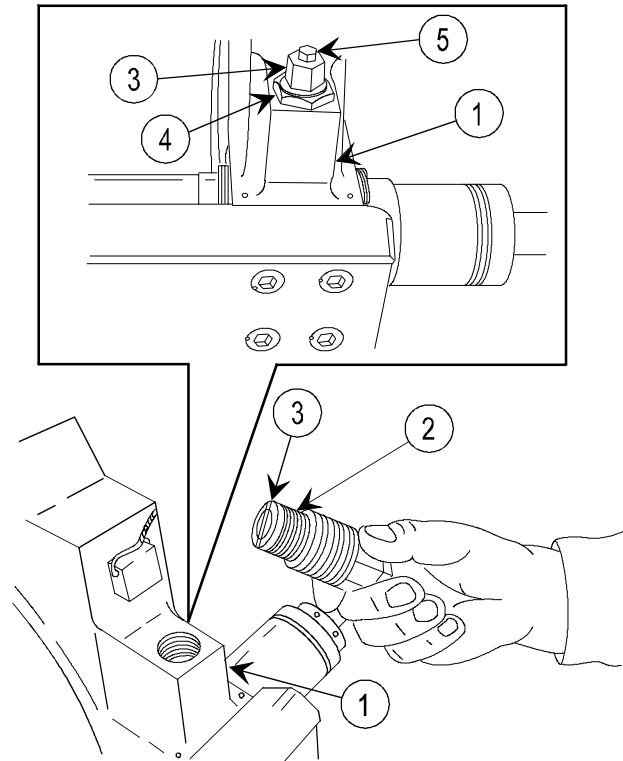

2-18.1. M45 RECOIL MECHANISM EXERCISER—EXERCISE INSTRUCTIONS

THIS TASK COVERS:

- a. Installation/operation
- b. Removal

INITIAL SETUP

Tools and Special Tools

- Artillery and turret mechanic's ordnance tool kit (SC 5180-95-CL-A12)
- Electrical extension cord
- Hydraulic M3 pump kit (7122378)
- Liquid tool assembly (8410594)
- Nitrogen charging kit (8449334)
- Recoil hose assembly (8432575)
- RE198 recoil exerciser kit (1025-01-417-9312)

Materials/Parts

- Oil (hydraulic fluid) (item 14, appx B)

References

- TM 9-1025-211-10
- TM 9-1025-211-20&P

Personnel Required: 2

- Artillery repairmen

Equipment Conditions

- Cannon tube elevated to level (TM 9-1025-211-10)
- Recuperator nitrogen pressure of 1100+50 psi
- Replenisher oil reserve at appropriate level

INSTALLATION/OPERATION

WARNING

Before starting procedure, be sure to clear the howitzer. Do not exercise the M45 recoil mechanism until the howitzer has been cleared to avoid injury and/or death.

The components of the RE198 recoil exerciser are heavy; use caution when handling components.

Do not operate the recoil exerciser with the cannon tube locked in the tube stow/travel lock position. Howitzer damage and/or personnel injury may occur.

NOTE

Before recoil exerciser is installed, ensure that recuperator nitrogen pressure is 1100+50 psi and replenisher oil level is at level listed below:

<u>Quarter</u>	<u>Oil Reserve Level</u>
1st	6
2nd	5
3rd	4
4th	3

If the howitzer has not been fired within last 90 days, perform the exercise procedure.

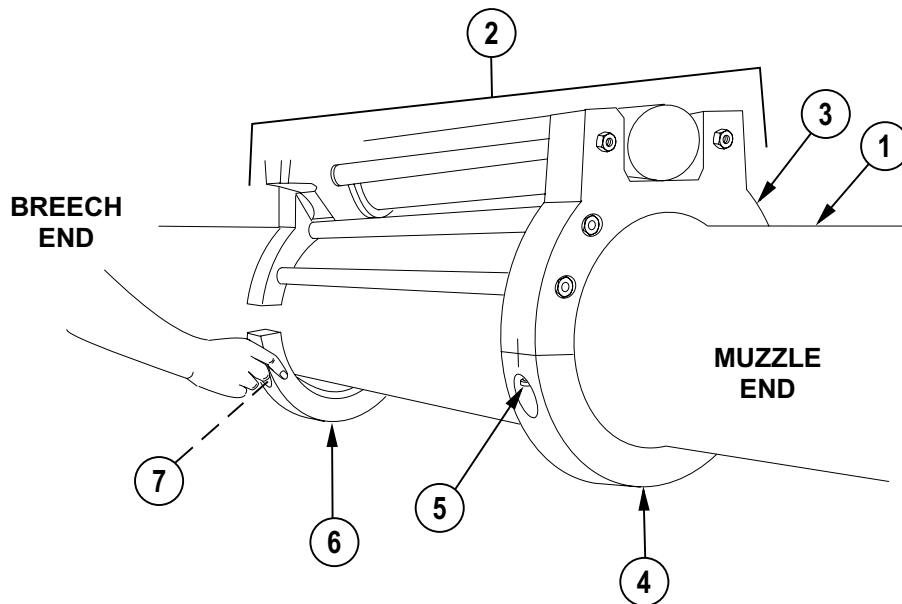

- 1 Level cannon tube (1). Refer to TM 9-1025-211-10.
- 2 Place cylinder support (2) on top of cannon tube (1) and position front chamfered yoke (3) in front of cannon tube taper.
- 3 Align front lower chamfered yoke half (4) with cylinder support (2) and install, using two bolts (5). Tighten bolts. Slide cylinder support to the rear until front chamfered yoke (3) seats against cannon tube taper.
- 4 Align rear lower yoke half (6) with cylinder support (1) and install, using two bolts (7). Tighten bolts.

2-18.1. M45 RECOIL MECHANISM EXERCISER—EXERCISE INSTRUCTIONS (cont)

INSTALLATION/OPERATION (cont)

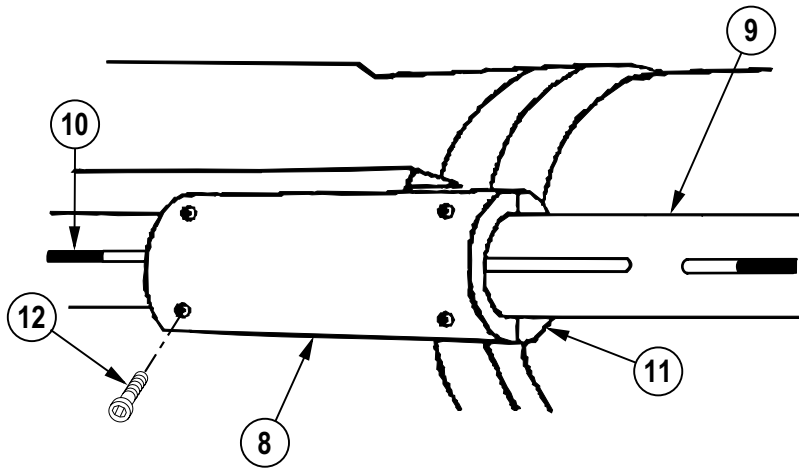

- 5 Align clamp block (8) with first available slot on replenisher rod indicator tube (9), in front of replenisher rod (10). Slide clamp block forward in slot until seated. Install clamp (11). Align threaded holes of clamp with holes in clamp block and install four screws (12). Tighten screws.

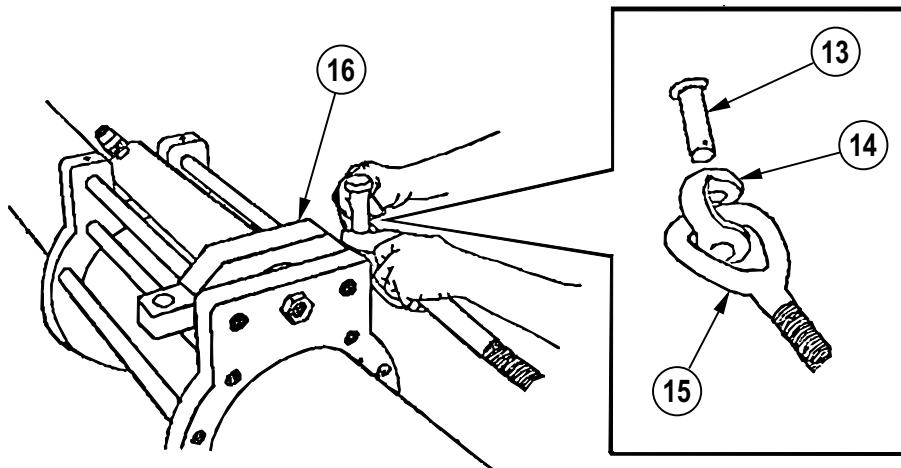

- 6 Remove shackle bolt (13) from 7/8 in. (2.22 cm) shackle (14). Install shackle through eye of turnbuckle (15). Align shackle with hole in cylinder yoke assembly (16) and install shackle bolt. Repeat with second turnbuckle. Install on opposite side of cylinder yoke assembly.

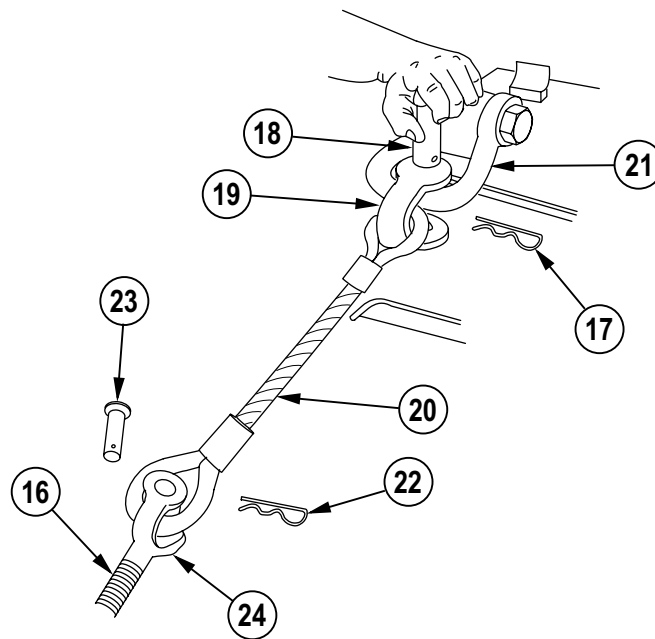

- 7 Remove cotter pin (17) and shackle pin (18) from 1.0 in. (2.54 cm) shackle (19). Install shackle through one eye of wire rope (20). Align shackle with cradle lifting eye (21) and install shackle pin and cotter pin. Repeat with second wire rope. Install on other cradle lifting eye.
- 8 Remove cotter pin (22) and shackle pin (23) from turnbuckle shackle (24). Align turnbuckle shackle with eye of wire rope (20) and install shackle pin and cotter pin. Repeat with second turnbuckle shackle. Hand tighten two turnbuckles (16) to remove slack from two wire ropes.

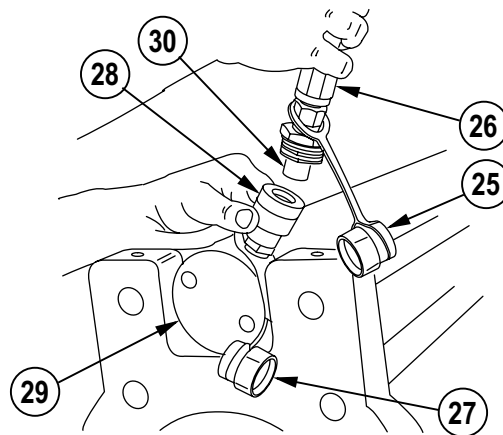

- 9 Remove protective dust cover (25) from recoil hose assembly (26). Remove protective dust cover (27) from quick disconnect (28) on cylinder assembly (29). Install quick disconnect (30) of recoil hose assembly to quick disconnect on cylinder assembly.

2-18.1. M45 RECOIL MECHANISM EXERCISER—EXERCISE INSTRUCTIONS (cont)

INSTALLATION/OPERATION (cont)

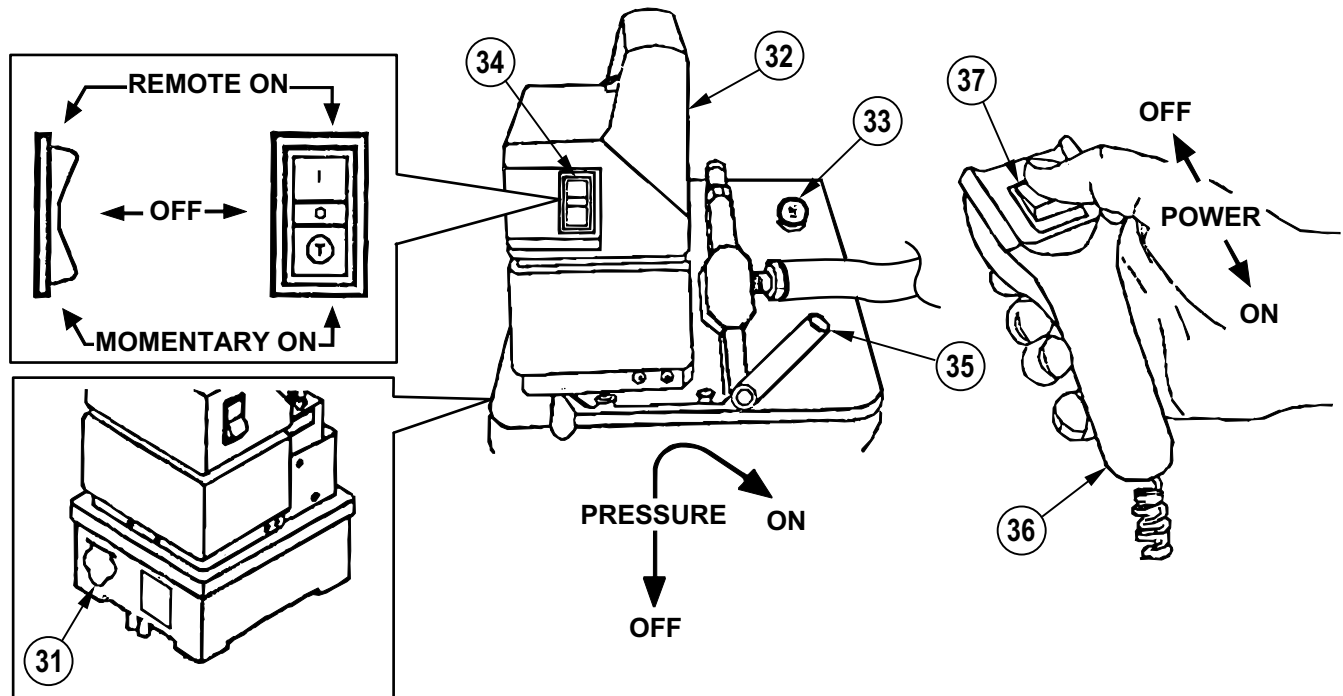

WARNING

To prevent injury to personnel, ensure that power switch of pump is either in the OFF position or the REMOTE ON position and that flow lever is in the OFF position before connection of electrical power.

- 10 Connect electrical extension cord to electrical connection point (31) of pump (32) and plug other end into a suitable wall outlet.

NOTE

Steps 11 through 16 apply to the exercise of the recoil mechanism.

WARNING

To prevent injury to personnel, relieve oil pressure at fill port.

- 11 Ensure that oil level in reservoir of pump (32) is within 1/2 in. (1.27 cm) of opening of fill port (33). Open plug of fill port one-half turn to allow reservoir to vent.
- 12 Place power switch (34) on pump (32) in the REMOTE ON position.
- 13 Place flow lever (35) in the ON position (rotated fully clockwise).

WARNING

Stand clear of the howitzer while operating the recoil exerciser. Ensure other personnel are also at a safe distance to avoid injury.

- 14 Move away from howitzer until cord of remote control (36) is extended to its full length. Press remote control button (37). Allow recoil exerciser cylinder to extend to its full length (approximately 14 in. (35.6 cm)). Release remote control button.
- 15 While recoil mechanism is being held out of "Battery", inspect recoil mechanism for leaks. If no leaks are found, release pressure by rotating flow lever (35) counterclockwise to OFF position. If a leak is found, refer to appropriate maintenance procedure for repair.
- 16 Repeat steps 13 through 15 a minimum of three times.

NOTE

Steps 17 through 20 apply to the exercise of the replenisher.

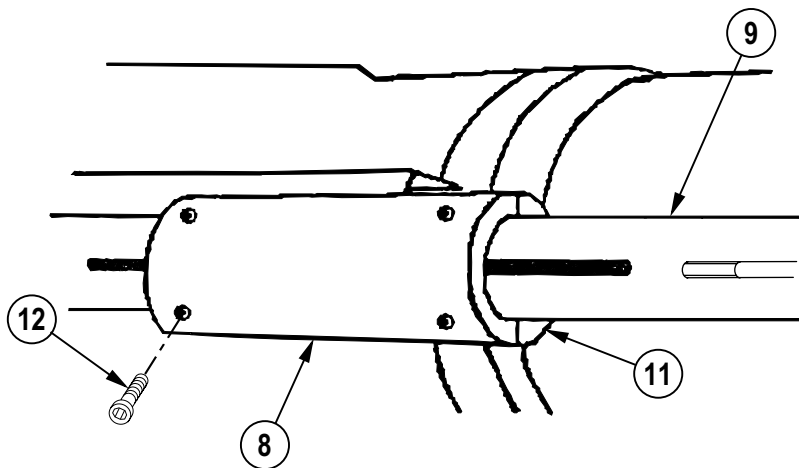

- 17 Remove four screws (12), clamp (11), and clamp block (8) from replenisher rod indicator tube (9). Store clamp, clamp block, and four screws according to unit standard operating procedure (SOP).

2-18.1. M45 RECOIL MECHANISM EXERCISER—EXERCISE INSTRUCTIONS (cont)

INSTALLATION/OPERATION (cont)

NOTE

Take note of replenisher rod reserve reading.

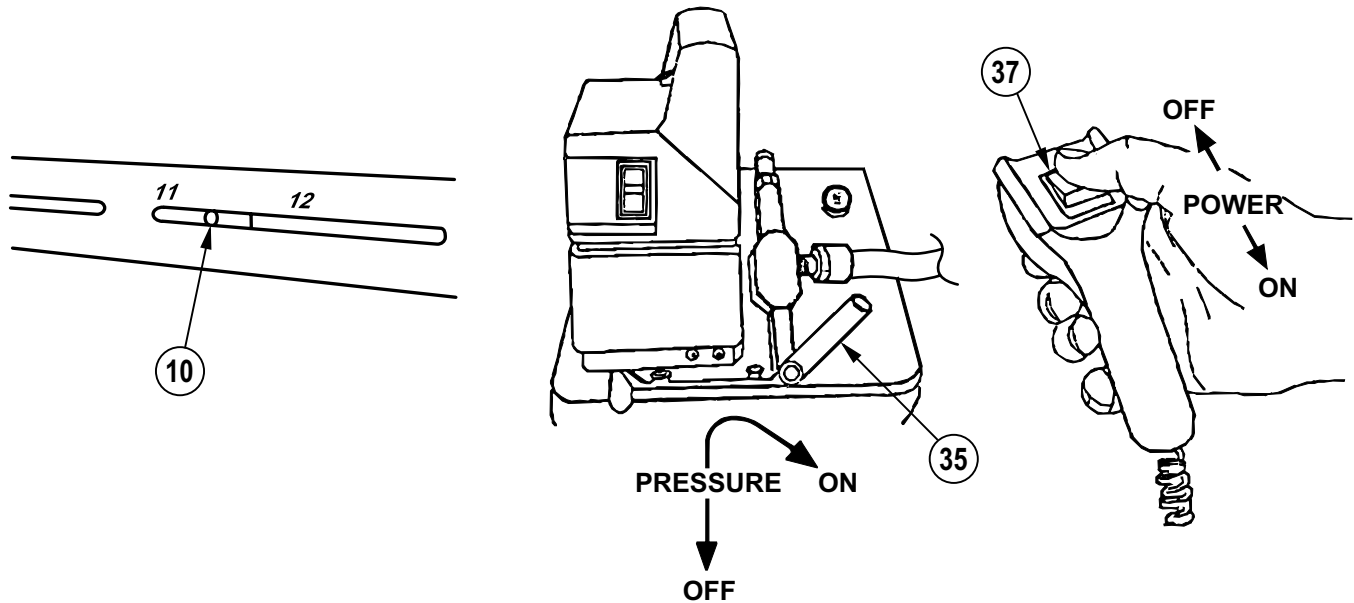

- 18 Position flow lever (35) to ON position (rotated fully clockwise). Press remote control button (37) and observe end of replenisher rod (10). Allow replenisher rod to extend beyond "11" reserves but not beyond "12" reserves.
- 19 Release pressure by rotating flow lever (35) counterclockwise to OFF position. Allow replenisher rod (10) to return to its original starting position.
- 20 Repeat steps 18 and 19 a minimum of three times.

REMOVAL

WARNING

The components of the RE198 recoil exerciser are heavy; use caution when handling components.

Ensure all hydraulic pressure has been released before disconnecting hose assembly. To avoid injury to personnel, do not remove hydraulic hose while hydraulic cylinder is extended.

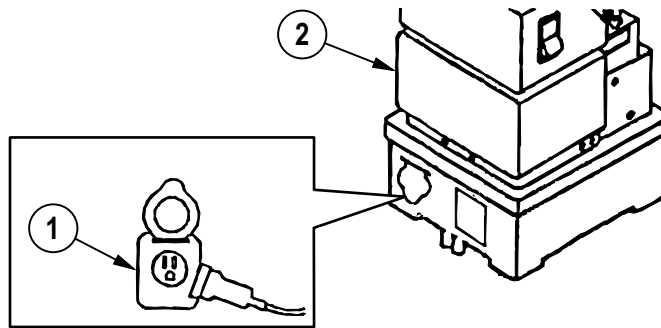

- 1 Disconnect electrical extension cord from wall outlet and electrical connection point (1) of pump (2). Store cord per unit SOP.

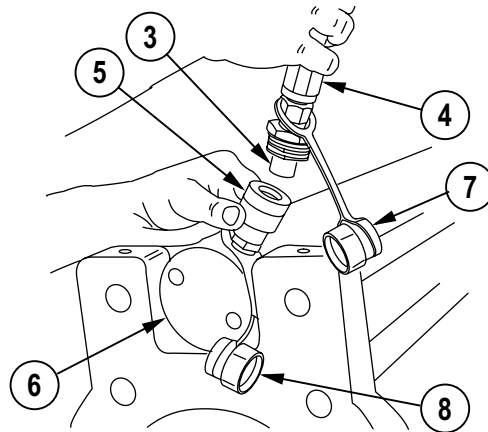

- 2 Disconnect quick disconnect (3) of recoil hose assembly (4) from quick disconnect (5) on cylinder assembly (6). Clean oil from quick disconnects. Install protective dust covers (7 and 8).

2-18.1. M45 RECOIL MECHANISM EXERCISER—EXERCISE INSTRUCTIONS (cont)

REMOVAL (cont)

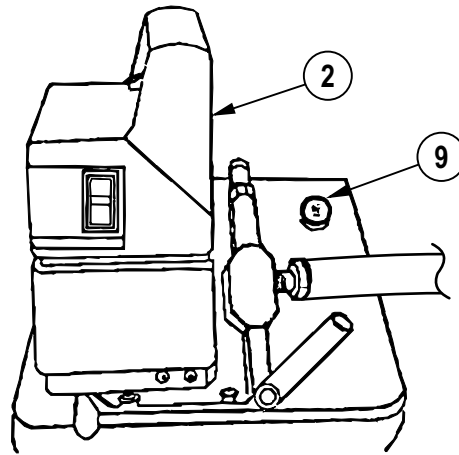

- 3 Close fill port (9) on pump (2). Clean oil from pump. Store pump per unit SOP.

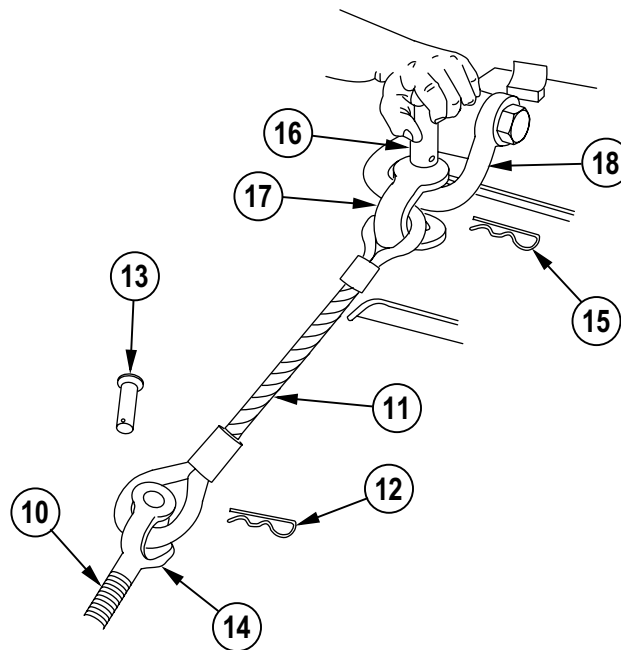

- 4 Turn turnbuckle (10) to remove tension from wire rope (11). Remove cotter pin (12) and shackle pin (13) from turnbuckle shackle (14). Repeat with second turnbuckle.
- 5 Remove cotter pin (15) and shackle pin (16) from 1.0 in (2.54 cm) shackle (17). Remove shackle from eye of wire rope (11) and cradle lifting eye (18). Repeat with second wire rope. Store wire ropes and shackles per unit SOP.

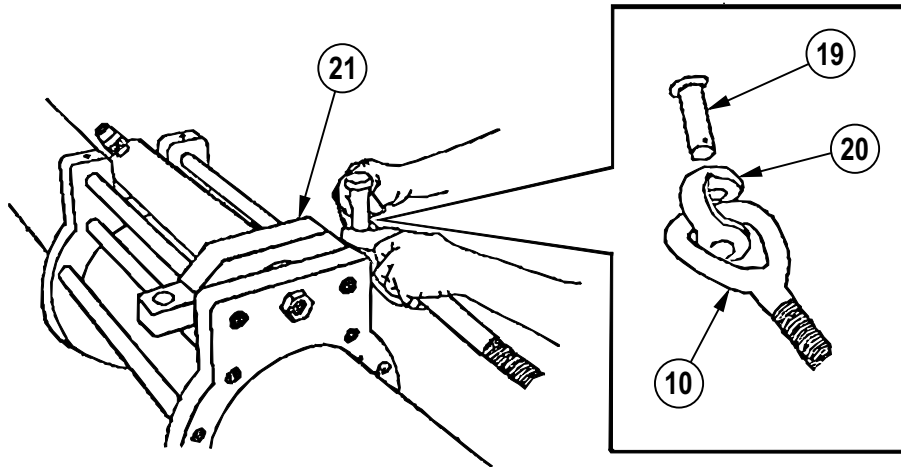

- 6 Remove shackle bolt (19) from 7/8 in. (2.22 cm) shackle (20). Remove shackle from cylinder yoke assembly (21) and eye of turnbuckle (10). Repeat with second turnbuckle. Store turnbuckles and shackles per unit SOP.

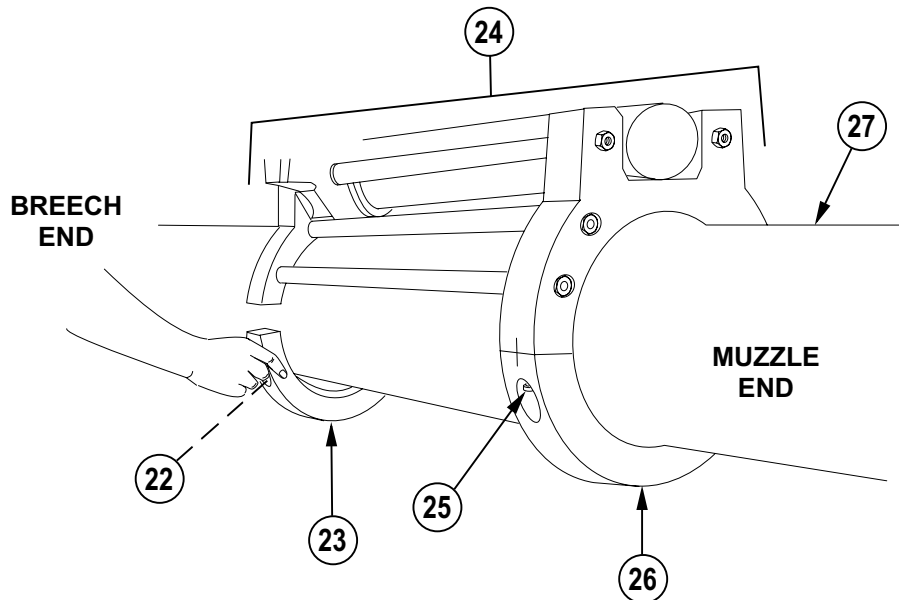

- 7 Remove two bolts (22) and rear lower yoke half (23) from cylinder support (24).
- 8 Remove two bolts (25) and front lower chamfered yoke half (26) from cylinder support (24).
- 9 Remove cylinder support (24) from cannon tube (27).
- 10 Store cylinder support (24), rear lower yoke half (23), front lower chamfered yoke half (26), and four bolts (22 and 25) per unit SOP.

Section V. M39 CARRIAGE MAINTENANCE INSTRUCTIONS

Section Index

Paragraph		Page
2-19.	M39 Carriage Miscellaneous Parts—Maintenance Instructions	2-139
2-20.	M39 Carriage Variable Recoil Parts—Maintenance Instructions	2-141
2-21.	Travel Lock Assembly—Maintenance Instructions	2-150
2-22.	Equilibrator Assembly—Maintenance Instructions	2-151
2-23.	Cradle Assembly—Maintenance Instructions	2-164
2-24.	Bearing Unit Housing—Maintenance Instructions	2-172
2-25.	Rest Assembly—Maintenance Instructions	2-175
2-26.	Guide Assembly—Maintenance Instructions	2-178
2-27.	Elevating Handwheel—Maintenance Instructions	2-181
2-28.	Elevating Angle Drive Unit—Maintenance Instructions	2-182
2-29.	Elevating Screw Assembly—Maintenance Instructions	2-191
2-30.	Bracket Assembly—Maintenance Instructions	2-201
2-31.	Friction Clutch—Maintenance Instructions	2-204
2-32.	Traversing Handwheel—Maintenance Instructions	2-221
2-33.	Traversing Drive Unit—Maintenance Instructions	2-222
2-34.	Traversing Shaft Assembly—Maintenance Instructions	2-227
2-35.	Traversing Angle Drive Unit—Maintenance Instructions	2-232
2-36.	Top Carriage Assembly—Maintenance Instructions	2-242
2-37.	Lock Assembly—Maintenance Instructions (Modified Howitzers Only)	2-257
2-38.	Bottom Carriage Assembly—Maintenance Instructions	2-258
2-38.1.	HyPAK Solenoid—Maintenance Instructions	2-264.2
2-39.	Ram Hydraulic Pumps—Maintenance Instructions	(2-265 blank)/2-266
2-40.	Manifold Assembly and Hydraulic Parts—Maintenance Instructions	2-271
2-41.	Speed Shift Cylinder Assembly—Maintenance Instructions	2-290
2-42.	Actuator Cylinder Assembly—Maintenance Instructions	2-298
2-43.	Detent Assembly—Maintenance Instructions	2-305
2-44.	Locking Assembly—Maintenance Instructions	2-307
2-45.	Right and Left Manual Brake Assembly—Maintenance Instructions	2-308
2-46.	Brake Head Assemblies—Maintenance Instructions	2-314
2-47.	Bottom Carriage Assembly - Wheel and Axle Parts—Maintenance Instructions	2-320
2-48.	Arm and Spindle Assembly—Maintenance Instructions	2-326
2-49.	Brake Precheck, Housing Assembly, and Filter Assembly—Maintenance Instructions	2-328
2-50.	Bottom Carriage Assembly - Rear Brake Parts Emergency Relay Valve— Maintenance Instructions	2-335
2-51.	Air Pressure Tank—Maintenance Instructions	2-339
2-52.	Power Booster Assembly—Maintenance Instructions	2-341
2-53.	Front Brake Parts—Maintenance Instructions	2-347
2-54.	Gun Tube Travel Lock—Maintenance Instructions	2-354
2-55.	Traverse Stop—Maintenance Instructions	2-357
2-56.	Left Clevis Assembly—Maintenance Instructions	2-359
2-57.	Left Trail Assembly—Maintenance Instructions	2-362
2-58.	Right Clevis Assembly—Maintenance Instructions	2-366
2-59.	Right Trail Assembly and Trail Locking Handle Assembly—Maintenance Instructions	2-370

2-19. M39 CARRIAGE MISCELLANEOUS PARTS—MAINTENANCE INSTRUCTIONS (cont)

DISASSEMBLY (cont)

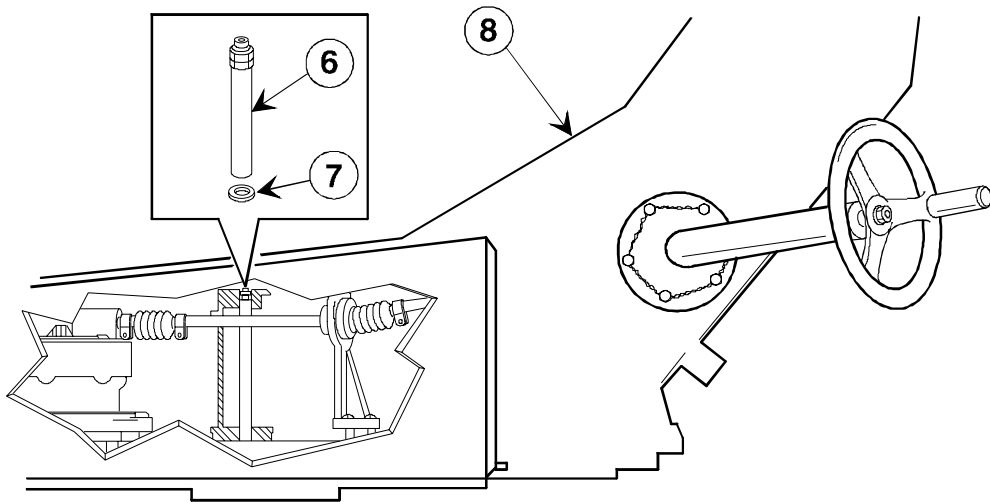

- 4 Remove lubrication extension (6) and preformed packing (7) from top carriage assembly (8).

INSPECTION/REPAIR

- 1 Check for broken, damaged, or missing parts.
- 2 Repair is by replacement of authorized parts (TM 9-1025-211-34P).

REASSEMBLY

- 1 Install new preformed packing (1) and lubrication extension (2).

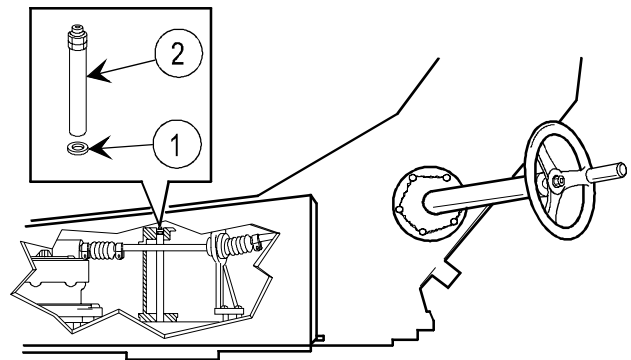

2 Deleted.

3 Deleted.

- 4 Install CAUTION decal (5) and four new screws (5.1).
- 5 Install direct fire instruction plate (6) and four screws (7).

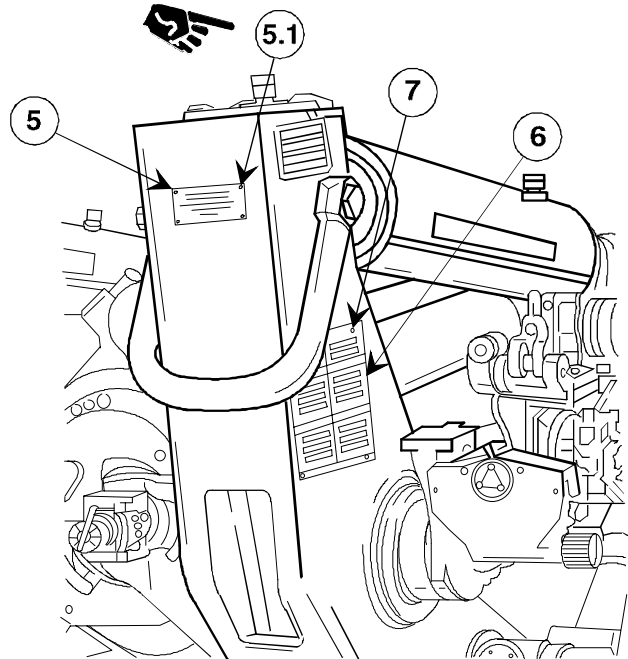

2-20. M39 CARRIAGE VARIABLE RECOIL PARTS—MAINTENANCE INSTRUCTIONS

THIS TASK COVERS:

- a. Disassembly b. Inspection/repair c. Reassembly d. Adjustment

INITIAL SETUP

Tools and Special Tools

- Artillery and turret mechanic's ordnance tool kit (SC 5180-95-CL-A12)
- M198 repairman field artillery tool kit (5911278)
- Torque wrench (GGG-W-00686)

Materials/Parts

- Chalk (item 6, appx B)
- Cotter pin (4) (MS24665-283)
- Cotter pin (MS24665-285)
- Lockwasher (9) (MS35335-35)
- Lock wire (item 34, appx B)
- Plastic pellet (8436778)
- PL-S (item 15, appx B)
- Preformed packing (4) (12008416)

References

- TM 9-1025-211-10
- TM 9-1025-211-34P

Equipment Conditions

- Cannon tube elevated or depressed to zero elevation (TM 9-1025-211-10)

2-20. M39 CARRIAGE VARIABLE RECOIL PARTS—MAINTENANCE INSTRUCTIONS (cont)

DISASSEMBLY

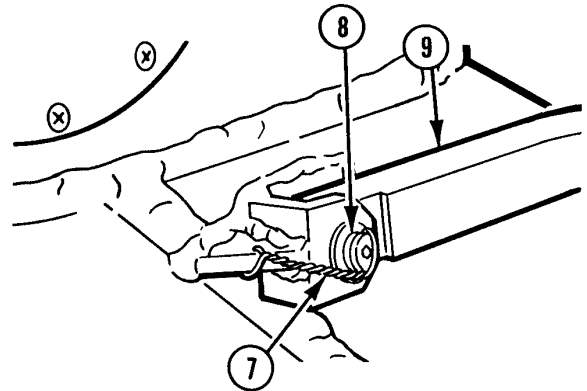
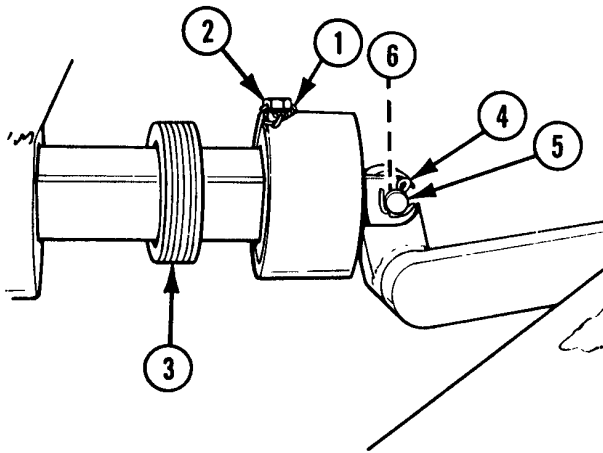

- 1 Remove lock wire (1) and screw (2).
- 2 Unscrew externally threaded ring (3).
- 3 Remove cotter pin (4), straight pin (5), and flat washer (6).

- 4 Remove lock wire (7), shoulder screw (8), and rigid connecting link (9).

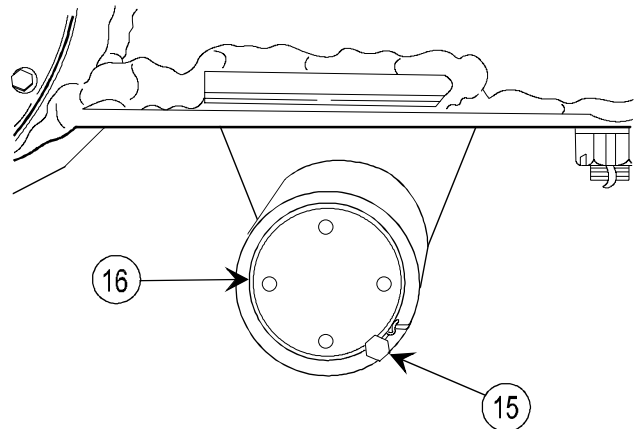
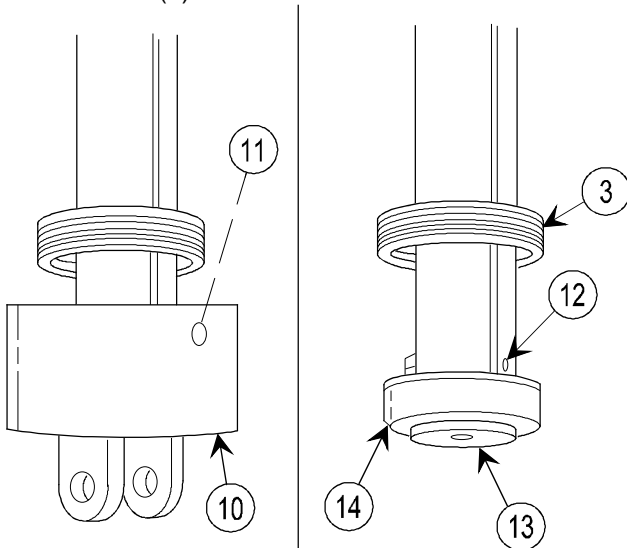

- 5 Remove connecting cap (10).
- 6 Drive out plastic pellet (11).
- 7 Remove spring pin (12), sleeve bushing (13), and ball bearing (14).
- 8 Remove externally threaded ring (3).

- 9 Remove screw (15) and externally threaded ring (16).

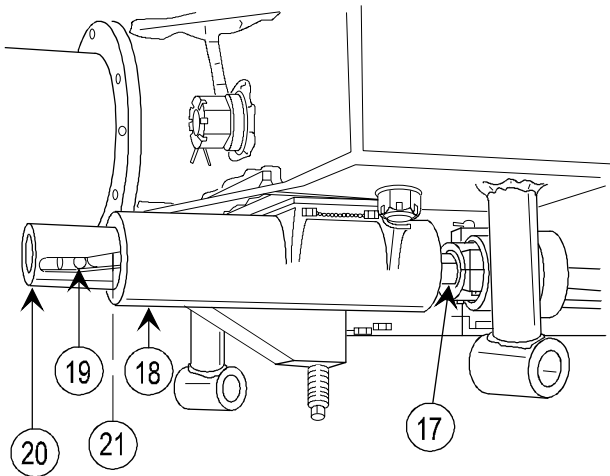

- 10 Push variable recoil shaft (17) through bearing unit housing (18) until straight pin (19) is exposed.
- 11 Remove straight pin (19).
- 12 Remove cam (20) and machine key (21).
- 13 Remove variable recoil shaft (17).
- 14 Slide pointer (22) with spring (23) off variable recoil shaft (17).

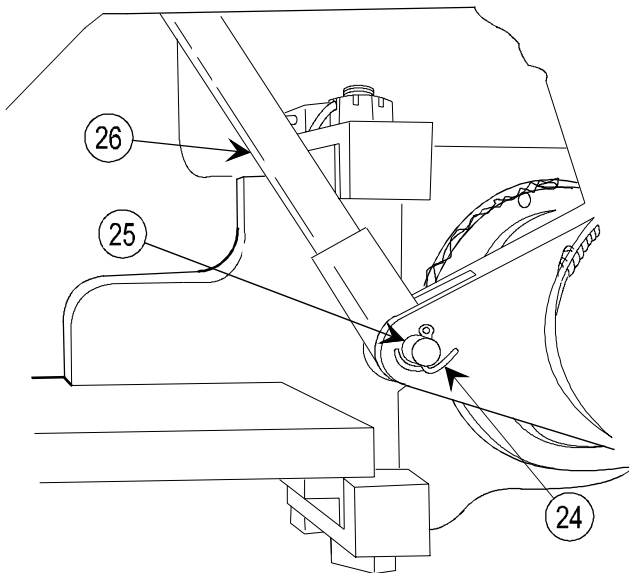

- 15 Remove cotter pin (24) and straight pin (25). Disconnect link (26).

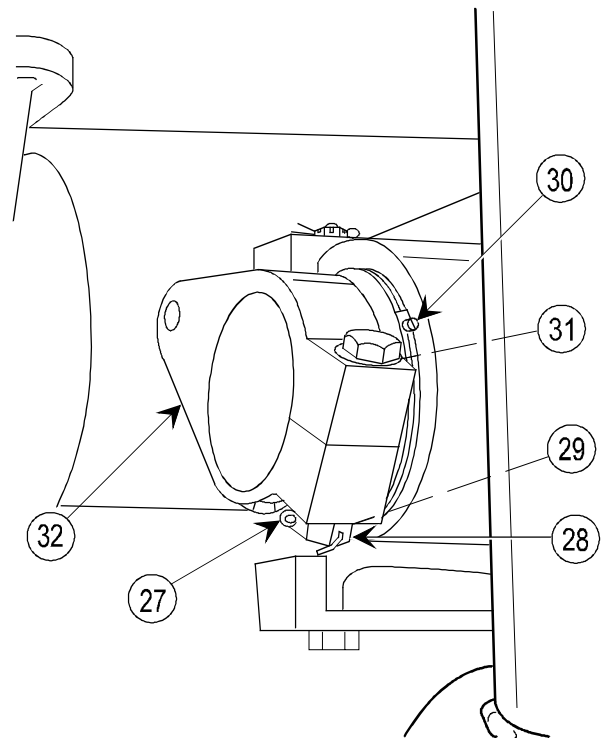

- 16 Remove cotter pin (27).
- 17 Remove hexagon nut (28), lockwasher (29), cap screw (30), shim (31), and lever (32).

2-20. M39 CARRIAGE VARIABLE RECOIL PARTS—MAINTENANCE INSTRUCTIONS (cont)

DISASSEMBLY (cont)

- 18 Remove lock wire and externally threaded ring (33).
- 19 Remove slide (34) and machine key (35).
- 20 Remove lock wire, capscrew (36), and nut (37).
- 21 Remove sleeve (38).
- 22 Remove two sleeve bearings (39).
- 23 Remove two cotter pins (40) and two hexagon nuts (41) from bolts (42).
- 24 Remove two bolts (42), two lockwashers (43), two blocks (44), and nonrotating eye bracket (45).

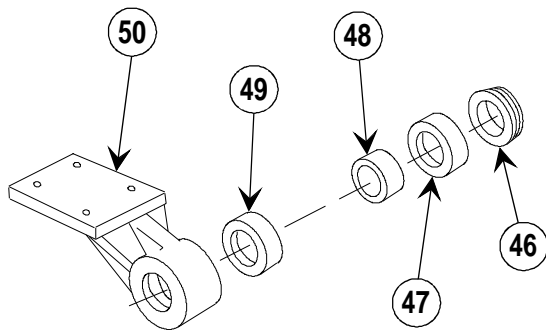
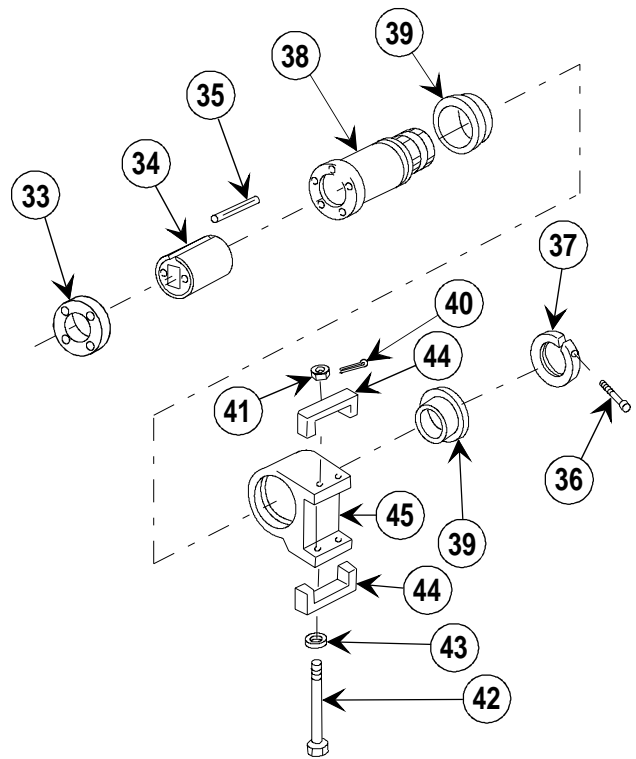

- 25 Remove lock wire from externally threaded ring (46).
- 26 Remove externally threaded ring (46), preformed packing (47), sleeve bearing (48), and preformed packing (49) from nonrotating eye bracket (50).

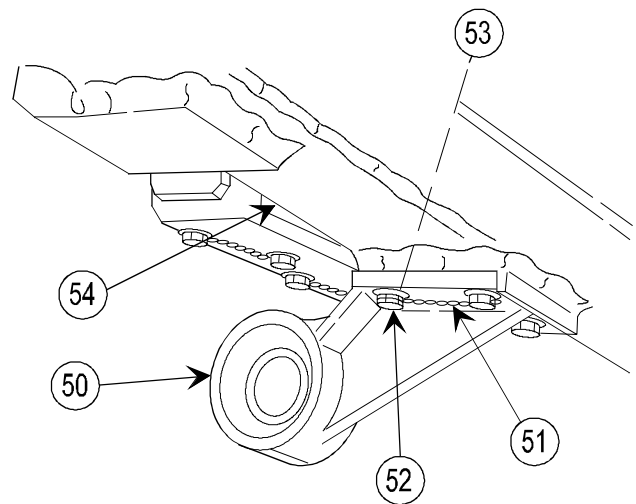

- 27 Remove lock wire (51). Remove four bolts (52), four lockwashers (53), and nonrotating eye bracket (50) from cradle assembly (54).

- 28 Remove lock wire and externally threaded ring (55), preformed packing (56), sleeve bearing (57), and preformed packing (58).
- 29 Remove four bolts (59), four lockwashers (60), and bearing unit housing (18).

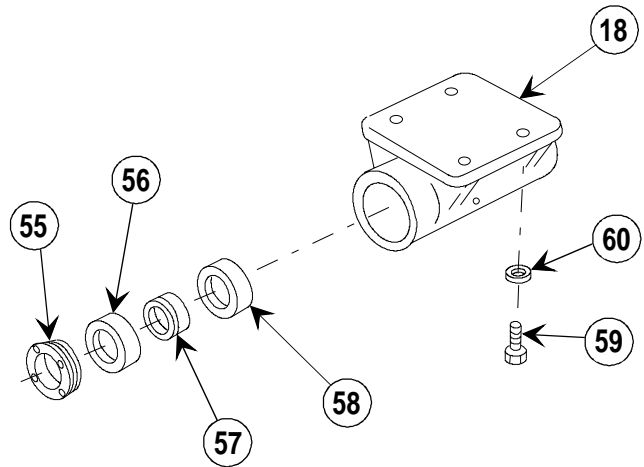

INSPECTION/REPAIR

- 1 Check for broken, damaged, or missing parts.
- 2 Repair is by replacement of authorized parts (TM 9-1025-211-34P).
- 3 Coat all preformed packings and bearings with PL-S before reassembling.

REASSEMBLY

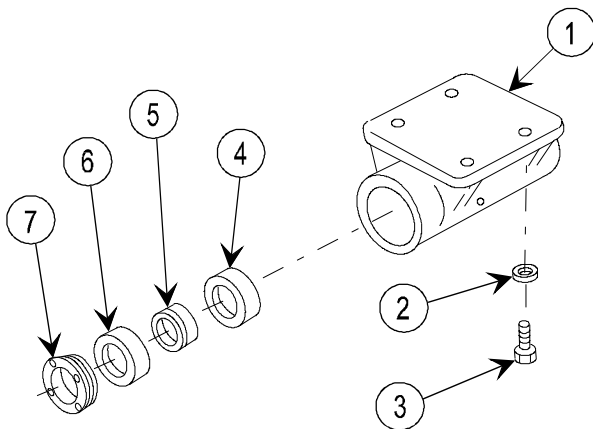

- 1 Install bearing unit housing (1), four new lockwashers (2), and four bolts (3).
- 2 Install new preformed packing (4), sleeve bearing (5), new preformed packing (6), externally threaded ring (7), and lock wire.

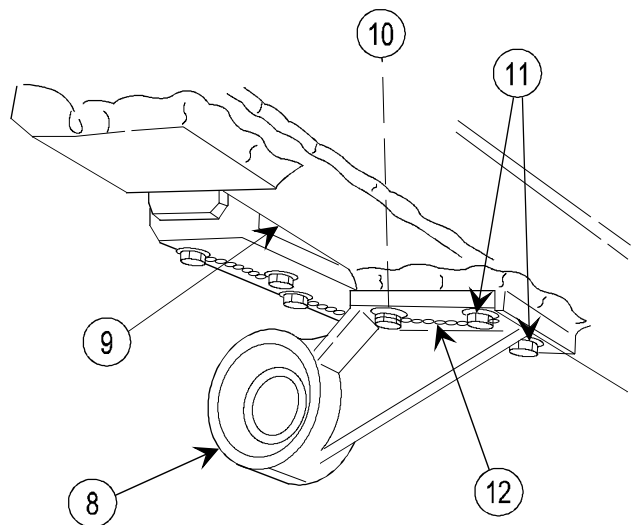

- 3 Place nonrotating eye bracket (8) on cradle assembly (9) and install four new lockwashers (10) and four bolts (11).
- 4 Install lock wire (12) on four bolts (11).

2-20. M39 CARRIAGE VARIABLE RECOIL PARTS—MAINTENANCE INSTRUCTIONS (cont)

REASSEMBLY (cont)

5 Insert new preformed packing (13), sleeve bearing (14), and new preformed packing (15) in nonrotating eye bracket (8).

6 Screw externally threaded ring (16) into nonrotating eye bracket (8) and secure with lock wire.

7 Install nonrotating eye bracket (17) on front yoke (18) and secure with blocks (19).

8 Insert two bolts (20) with two new lockwashers (21) through blocks (19). Install fingertight with two hexagon nuts (22), and install two new cotter pins (23).

9 Install two sleeve bearings (24).

10 Insert sleeve (25) in nonrotating eye bracket (17).

11 Install nut (26), capscrew (27), and lock wire.

NOTE

Tighten nut (26) only enough to reduce end play of sleeve (25). The sleeve must rotate in the bracket freely. Tighten capscrew (27) in nut (26) and recheck that sleeve (25) is still free to rotate before installing lock wire on capscrew (27).

12 Place machine key (28) on slide (29).

13 Insert slide (29) in nonrotating eye bracket (17).

14 Insert externally threaded ring (30) in nonrotating eye bracket (17), and secure with lock wire.

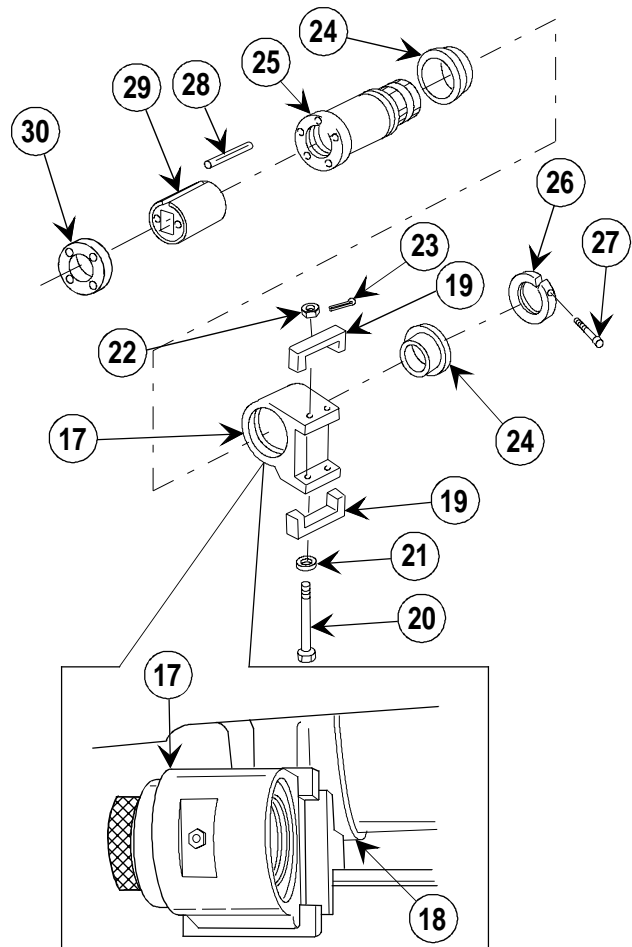
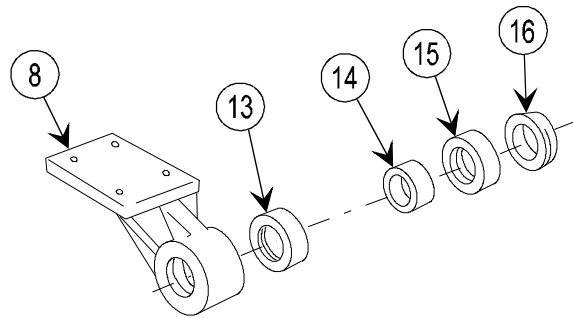

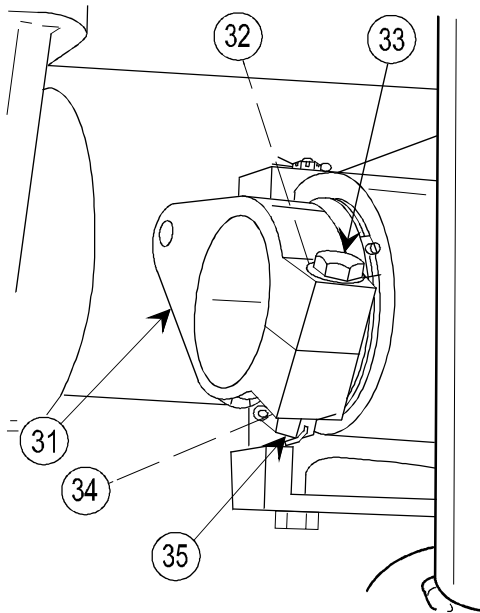

- 15 Install lever (31), shim (32), capscrew (33), new lockwasher (34), and hexagon nut (35), but do not tighten.

NOTE

Lever (31) must be adjusted (p 2-149) after completion of reassembly.

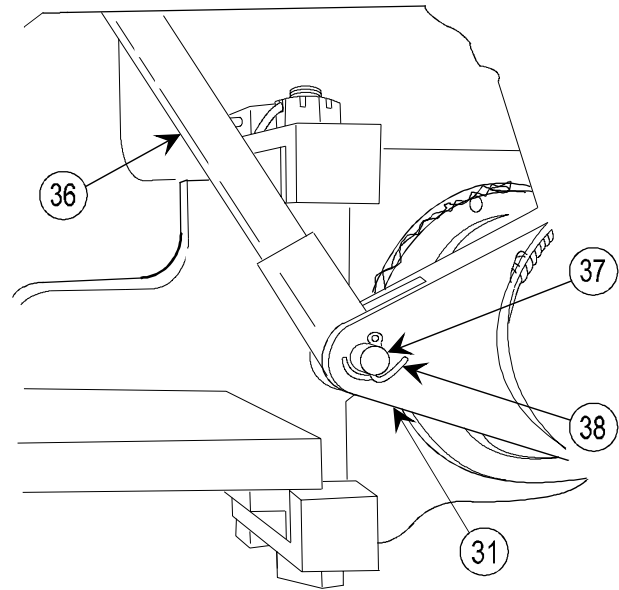

- 16 Connect link (36) to lever (31).

CAUTION

Install straight pin (37) with head toward breech end.

- 17 Install straight pin (37) and new cotter pin (38).

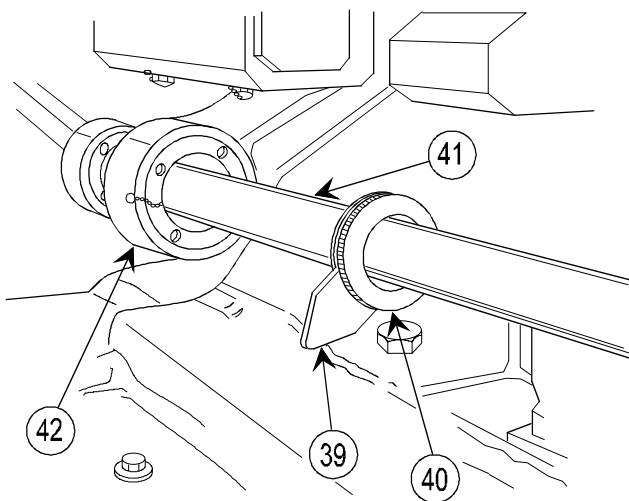

- 18 Install pointer (39) with spring (40) on variable recoil shaft (41).
- 19 Install variable recoil shaft (41) through nonrotating eye bracket (42).

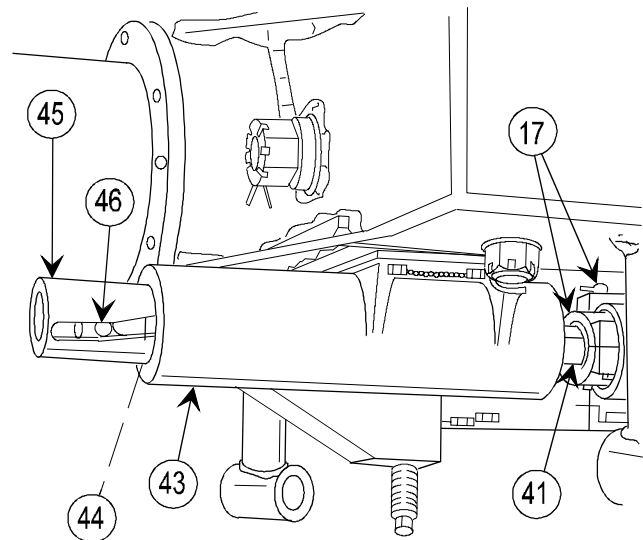

- 20 Install variable recoil shaft (41) through nonrotating eye bracket (17) and bearing unit housing (43).
- 21 Install machine key (44) and cam (45) in bearing unit housing (43).
- 22 Place straight pin (46) through cam (45) into variable recoil shaft (41).

2-20. M39 CARRIAGE VARIABLE RECOIL PARTS—MAINTENANCE INSTRUCTIONS (cont)

REASSEMBLY (cont)

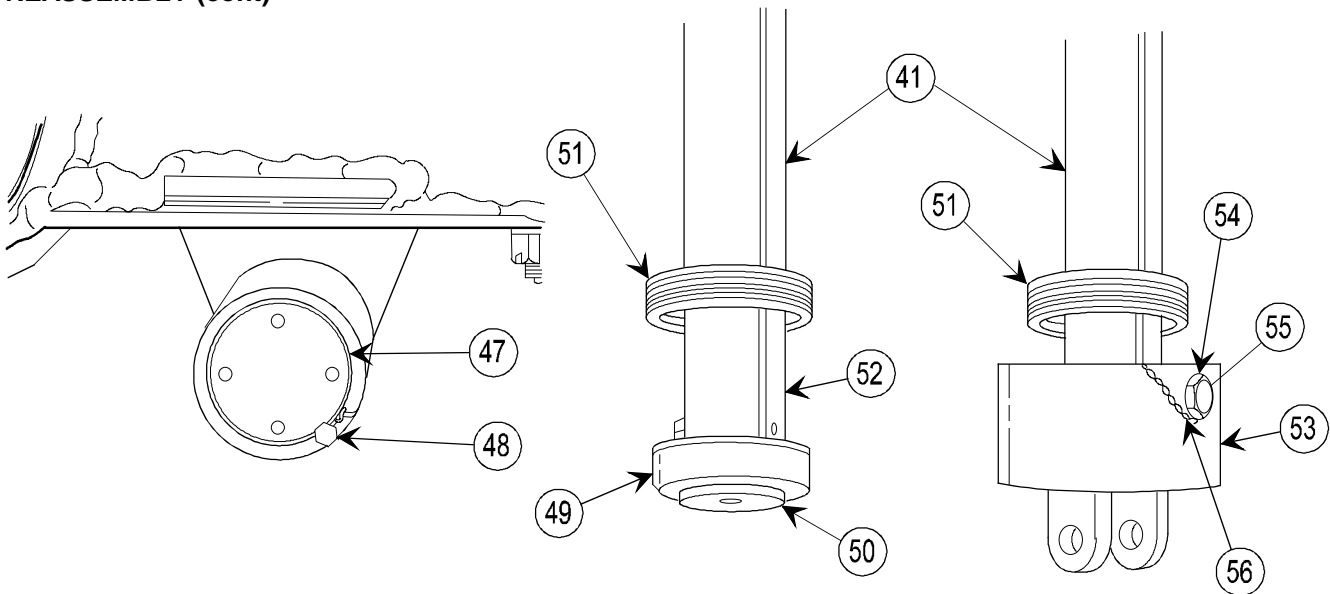

- 23** Install externally threaded ring (47) and screw (48).
- 24** Install ball bearing (49) on sleeve bushing (50).
- 25** Install externally threaded ring (51), sleeve bushing (50) with ball bearing (49) on variable recoil shaft (41), and spring pin (52) in variable recoil shaft (41).
- 26** Screw externally threaded ring (51) into connecting cap (53), plastic pellet (54), screw (55), and lock wire (56).

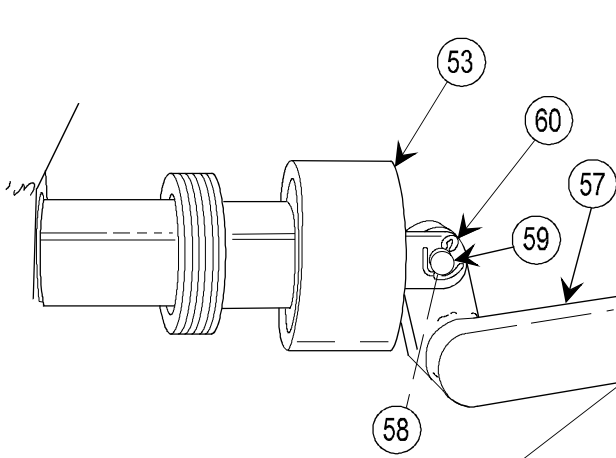

- 27** Attach rigid connecting link (57) to connecting cap (53) with flat washer (58), straight pin (59), and new cotter pin (60).

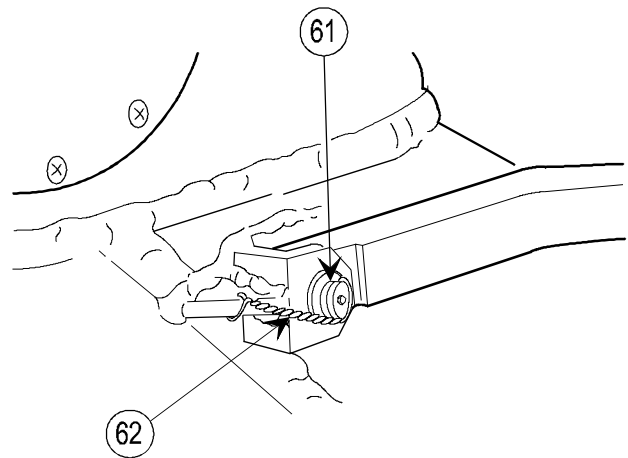

- 28** Install shoulder screw (61) and lock wire (62).

ADJUSTMENT

- 1 Place cannon tube (1) at minimum elevation (50 mils or less) on the baseplate.
- 2 Remove cotter pin (2).
- 3 Loosen hexagon nut (3).
- 4 Set lever (4) so that 105-degree mark (5) on end of recuperator cylinder assembly is centered within notch (6) of lever (4).

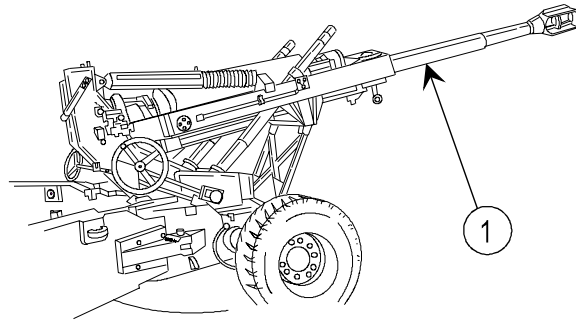

NOTE

Shim (7) must be thick enough so that hole in capscrew (8) is aligned with slots in hexagon nut (3) when properly torqued.

- 5 Tighten hexagon nut (3), and torque to 25 to 28 ft-lb (34 to 38 N-m).

NOTE

To observe the 55-degree mark (9) from the ground, apply chalk mark (10) to the outside dimension of the recuperator cylinder.

105-degree mark (5) must lie within notch (6) for all cannon tube elevations of minus 50 mils or less, and 55-degree mark (9) must lie within notch (6) when cannon tube is elevated to 1025 mils or more.

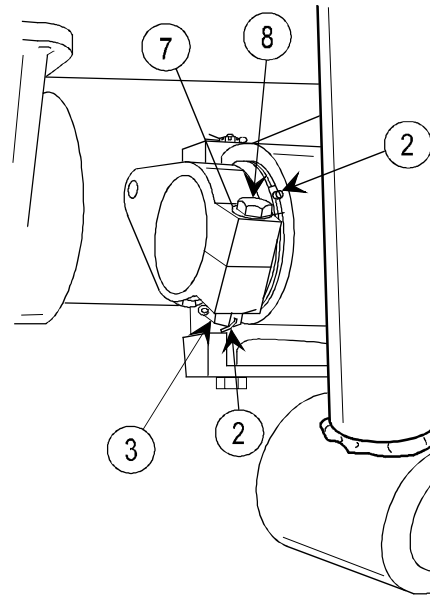

- 6 Place cannon tube (1) at 1025 mils elevation; 55-degree mark (9) must be centered within notch (6) of lever (4). If not, repeat steps 2 thru 6 placing cannon tube at an elevation lower than 50 mils.
- 7 Install cotter pin (2).

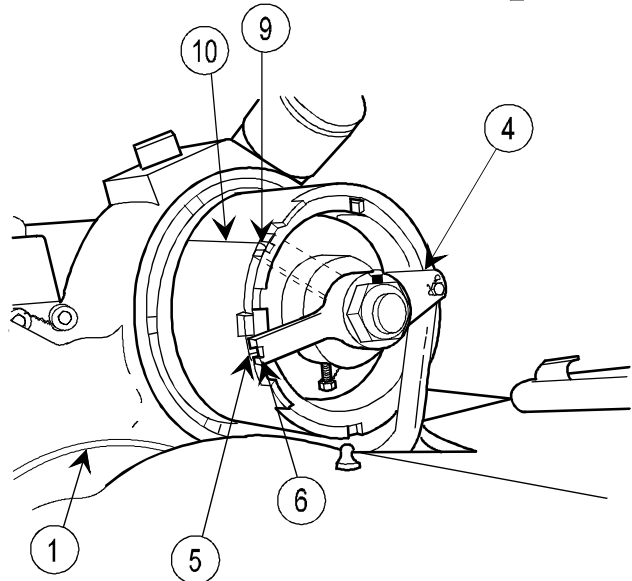

2-22. EQUILIBRATOR ASSEMBLY—MAINTENANCE INSTRUCTIONS

THIS TASK COVERS:

- | | |
|----------------|----------------------|
| a. Deleted | b. Removal |
| c. Disassembly | d. Inspection/repair |
| e. Reassembly | f. Installation |

INITIAL SETUP

Tools and Special Tools

Artillery and turret mechanic's ordnance tool kit (SC 5180-95-CL-A12)
Artillery field maintenance shop equipment (SC 4933-95-CL-A12)
M198 repairman field artillery tool kit (5911278)
Nitrogen hose assembly (12008918)
Nitrogen tank (BBN-411)
3-ton hoist available

Materials/Parts

Grease (item 11, appx B)
Lock wire (item 37, appx B)
Soap (item 30, appx B)

Personnel Required: 2

Artillery repairmen to lift and charge equilibrator assemblies

References

TM 9-254
TM 9-1025-211-10
TM 9-1025-211-34P

Equipment Conditions

Equilibrator balance adjustment positioned at zero (TM 9-1025-211-10)
Travel lock assembly engaged (TM 9-1025-211-10)
Nitrogen pressure bled from equilibrators (TM 9-1025-211-20&P)

General Safety Instructions

WARNING

All lifting devices must be checked in accordance with local Standing Operating Procedure (SOP) to make sure they are in good working condition before starting the lifting operation.

NOTE

All data on pages 152 through 155 deleted.

2-22. EQUILIBRATOR ASSEMBLY—MAINTENANCE INSTRUCTIONS (cont)

REMOVAL

NOTE

Removal procedures are written for one equilibrator cylinder (1), but apply to both.

- 1 Remove protective dust cap (2).
- 2 Remove valve cap (3).

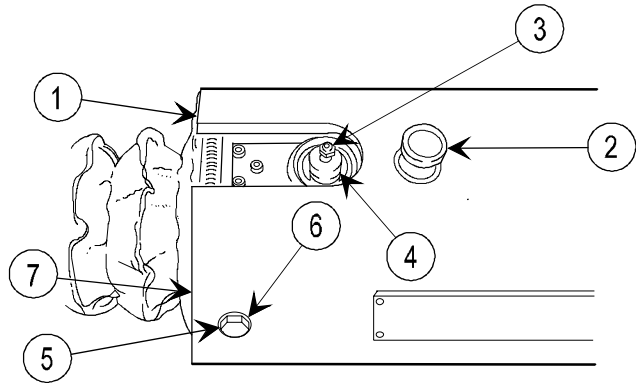

WARNING

Equilibrator nitrogen pressure must be bled to 0 (zero) psi before any maintenance is performed on the equilibrator or its associated parts.

- 3 Open check valve (4) slowly until pressure begins to bleed off. As pressure decreases, open completely until all nitrogen pressure is released from equilibrator cylinder (1); close check valve.

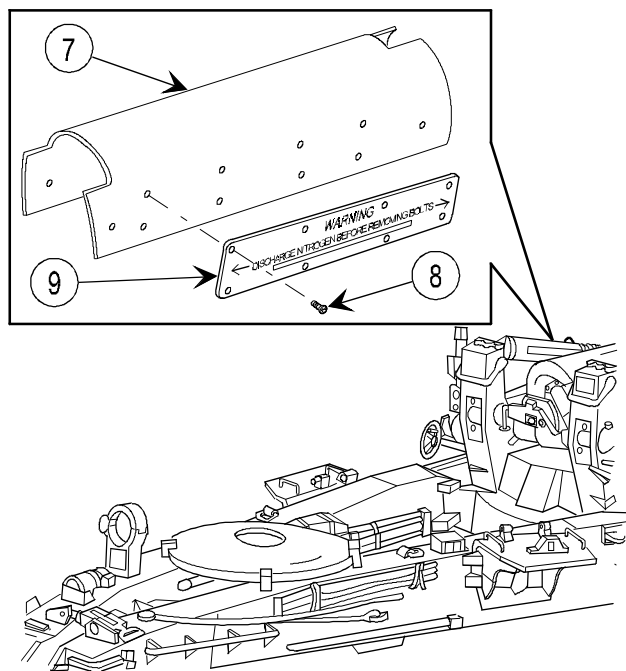

NOTE

Procedure is written for only one ballistic shield, but applies to both.

Each ballistic shield has two warning plates, but procedures are written for one.

- 4 Remove lock wire, four screws (5) and four lockwashers (6) securing ballistic shield (7) on equilibrator cylinder; remove ballistic shield.
- 5 Remove eight rivets (8) and warning plate (9) from ballistic shield (7) (modified howitzers only).

NOTE

The equilibrator cylinder (1) weighs approximately 85 lb (39 kg). If a sling (10) and 3-ton hoist (11) are not available for removal, additional help may be required.

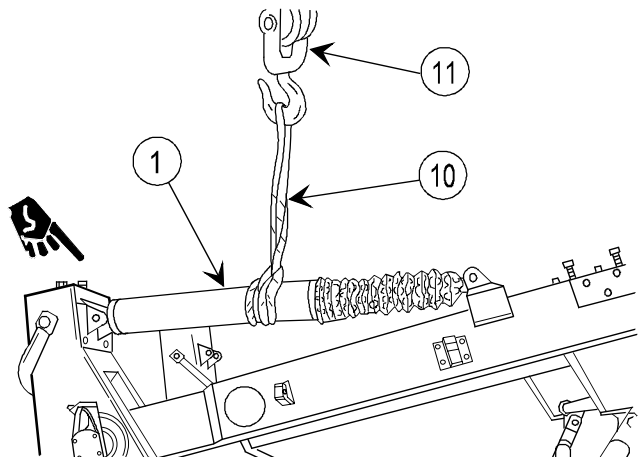

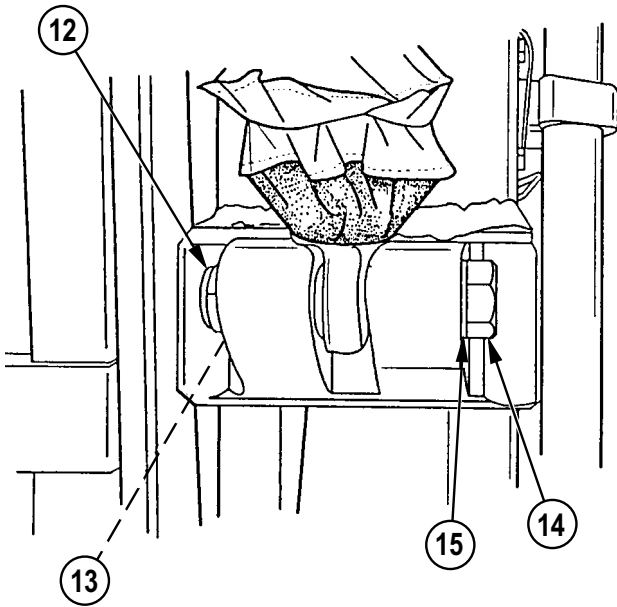

- 6 Remove nut (12) and flat washer (13) from front of equilibrator cylinder (1).
- 7 Remove bolt (14) and flat washer (15).

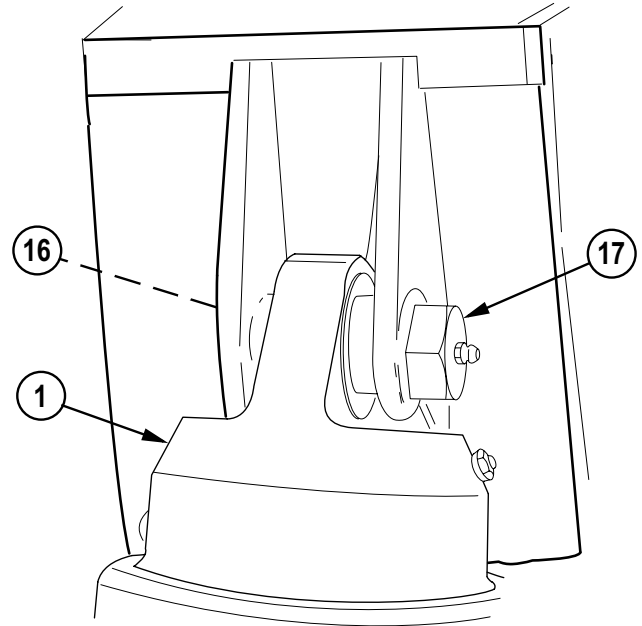

- 8 Remove nut (16) from rear of equilibrator cylinder (1).
- 9 Remove bolt (17).

NOTE

It may be necessary to pry eyebolts from mounting brackets prior to lifting with hoist.

- 10 Remove equilibrator cylinder (1) using sling (10) and 3-ton hoist (11).

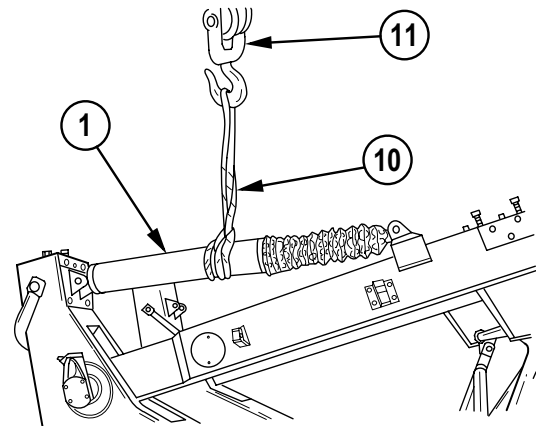

DISASSEMBLY

- 1 Remove hose clamp (1).
- 2 Pull back rubber bellows (2) to expose the equilibrator rod (3).

CAUTION

Use proper tool to prevent damaging equilibrator rod (3).

- 3 Holding equilibrator rod (3) with strap wrench, unscrew bearing (4) and remove.

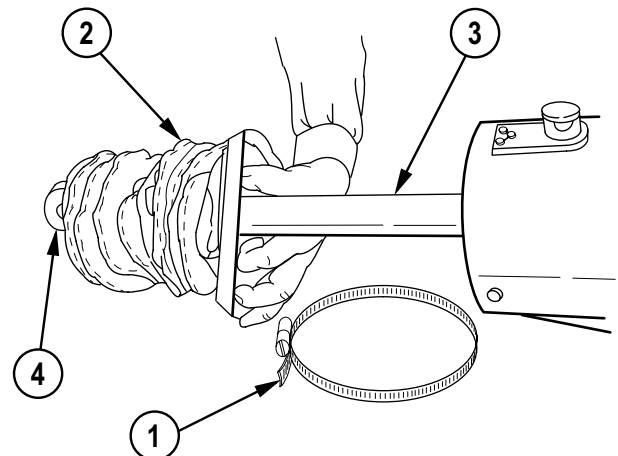

2-22. EQUILIBRATOR ASSEMBLY—MAINTENANCE INSTRUCTIONS (cont)

DISASSEMBLY (cont)

- 4 Remove hose clamp (5).
- 5 Remove rubber bellows (2).

WARNING

All pressure must be released from equilibrator cylinder (6) before replacement of check valves can be done.

NOTE

Equilibrator need not be removed from howitzer to replace check valve (7).

- 6 Remove three screws (8) and mounting plate (9).
- 7 Unscrew check valve (7) and remove.

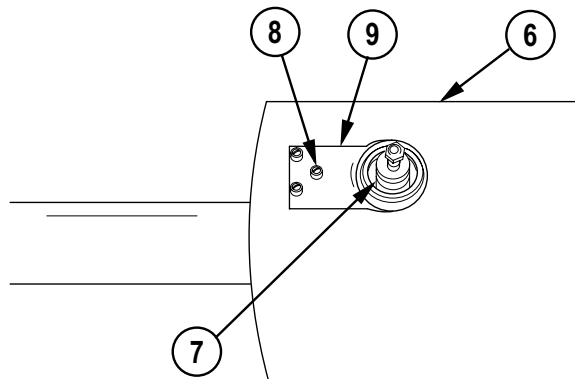
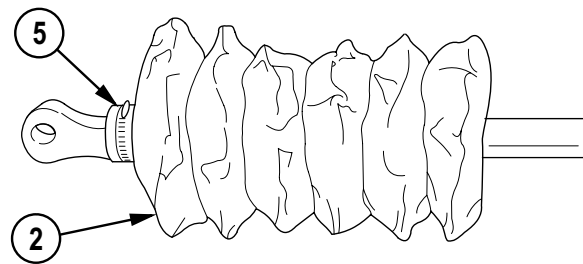

- 8 Remove breather (10).
- 9 Remove bearing (11).

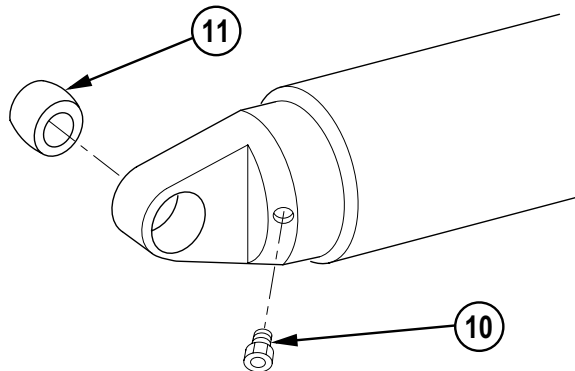

NOTE

Items 12 thru 14 are not found on new design equilibrator assemblies.

- 10 Remove lock wire and eight screws (12).
- 11 Remove retainer (13) and ring (14).

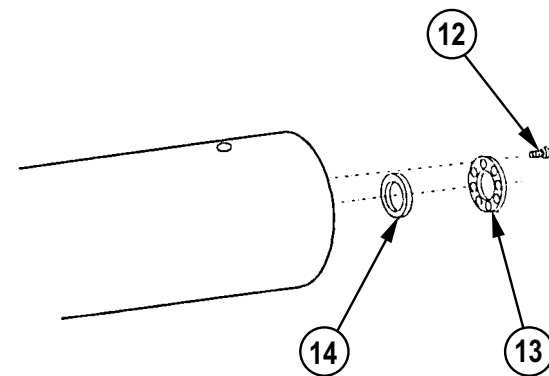

INSPECTION/REPAIR

- 1 Check for broken, damaged, or missing parts.
- 2 Repair is by replacement of authorized parts (TM 9-1025-211-34P).

REASSEMBLY

NOTE

Items 1 thru 3 are not found on new design equilibrator assemblies.

- 1 Install ring (1) and retainer (2).
- 2 Install eight screws (3) and lock wire.

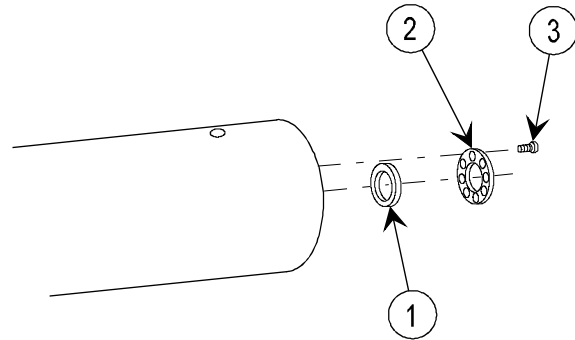

- 3 Install bearing (4).
- 4 Install breather (5).
- 5 Lubricate new preformed packing (6) provided with check valve with grease. Install on check valve (7).

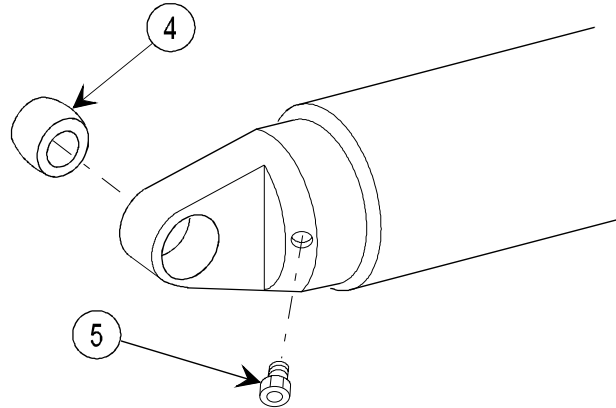

CAUTION

Be sure finished surface of equilibrator cylinder is clean and free of nicks and scratches before installing check valve.

- 6 Install check valve (7). Torque body assembly (8) against finished surface of equilibrator assembly to 100 in.-lb (11 N-m). Remove torque wrench.

NOTE

Never turn check valve counterclockwise to aline holes in mounting plate.

- 7 Assemble mounting plate (9) to check valve (7) to the nearest alinement position. Tighten check valve until holes in mounting plate aline with tapped cylinder holes.

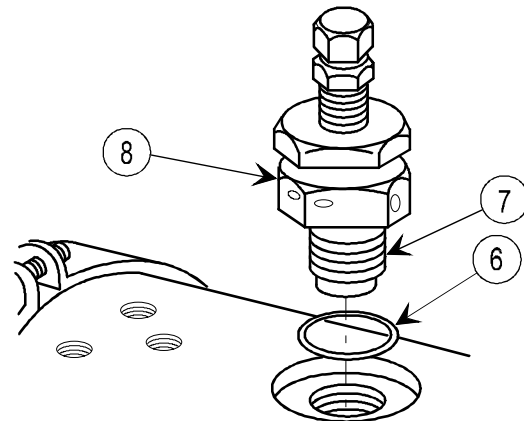

- 8 Install three screws (10).
- 9 Torque swivel nut (11) to 120-130 in.-lb (14 to 15 N-m) twice, loosening swivel nut after each application of torque. Tighten swivel nut to 100 to 110 in.-lb (11 to 12 N-m). (On check valves MS28889-2 only.)
- 10 Install valve cap (12) and torque to 10 to 12 in.-lb (14 to 16 N-m). Install dust cover (13) on check valve.

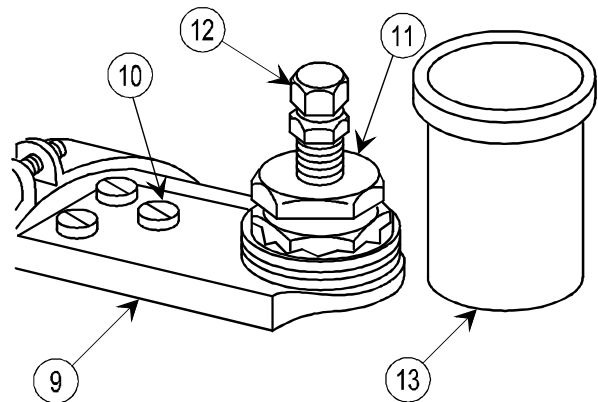

2-22. EQUILIBRATOR ASSEMBLY—MAINTENANCE INSTRUCTIONS (cont)

REASSEMBLY (cont)

- 11 Install rubber bellows (14) over equilibrator rod (15).

CAUTION

Do not overtighten hose clamp (16), as rubber bellows (14) will be deformed.

- 12 Install hose clamp (16) and tighten.
- 13 Install bearing (17) and tighten while holding equilibrator rod (15) with strap wrench.
- 14 Position rubber bellows (14) on equilibrator cylinder (18).
- 15 Install hose clamp (19) and tighten; position adjusting screw (20) on bottom side of equilibrator cylinder (18).

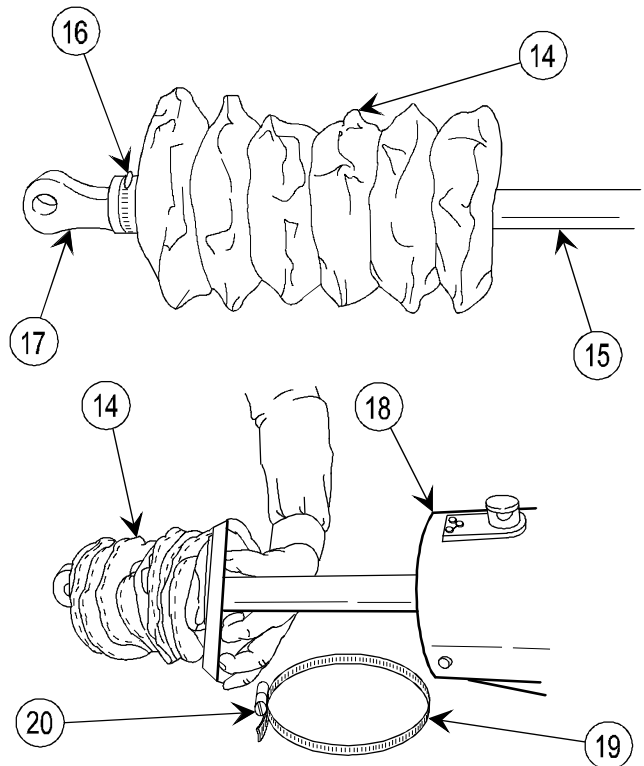

INSTALLATION

- 1 Attach sling (1) to equilibrator cylinder (2), and attach to 3-ton hoist (3).

NOTE

Replace equilibrator cylinder (TM 9-1025-211-34P) if nitrogen pressure leaks between equilibrator rod and head or between head and equilibrator cylinder.

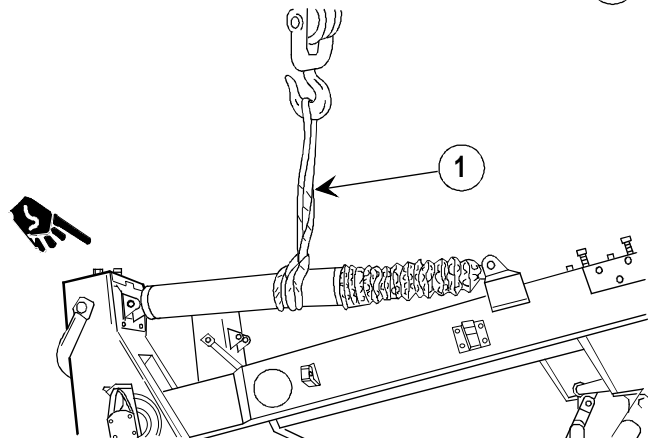

- 2 Install equilibrator cylinder (2) on cradle assembly (4) and position in center of rear bearing (5).
- 3 Install bolt (6) in rear of equilibrator cylinder (2).
- 4 Install nut (7) and tighten.

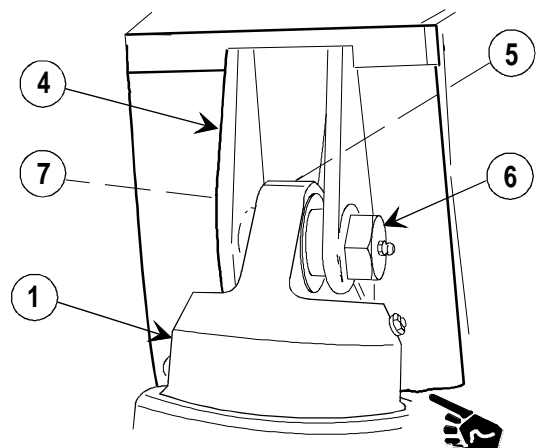

- 5 Install bearing (8) in center of bracket (9). Install flat washer (10) and bolt (11) in bracket (9) and bearing (8).
- 6 Install flat washer (12) and nut (13); torque nut to 10 ft-lb (14 N-m).

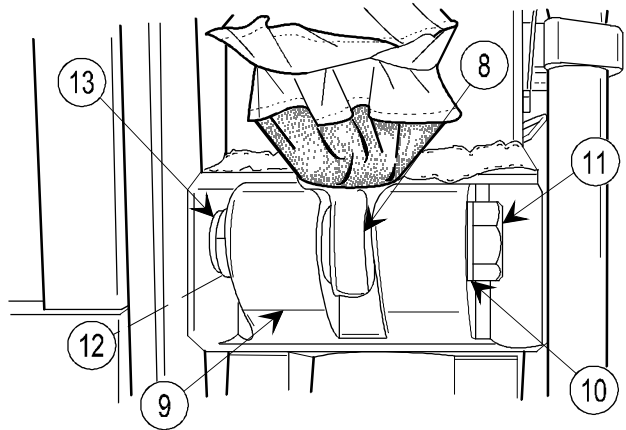

- 7 Remove sling (1) and 3-ton hoist (3).

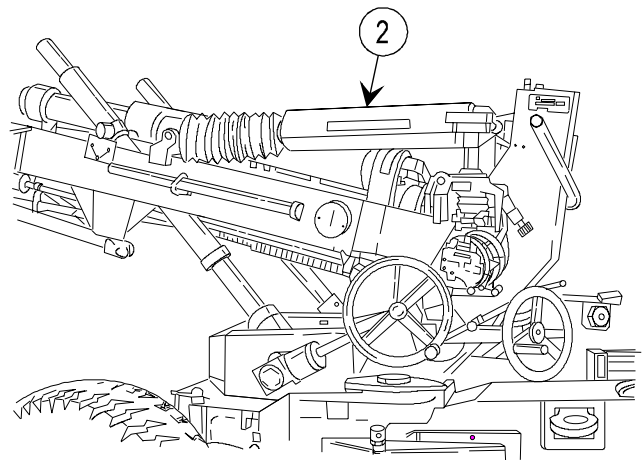

- 8 Charge equilibrator cylinder (2) with nitrogen (TM 9-1025-211-20&P).

NOTE

Install rivets in accordance with TM 9-254.

Procedures for installation of warning plate apply to two warning plates on each ballistic shield, but are written for one.

- 9 Position warning plate (14) on each ballistic shield (15) and secure with eight rivets (16) (modified howitzers only).

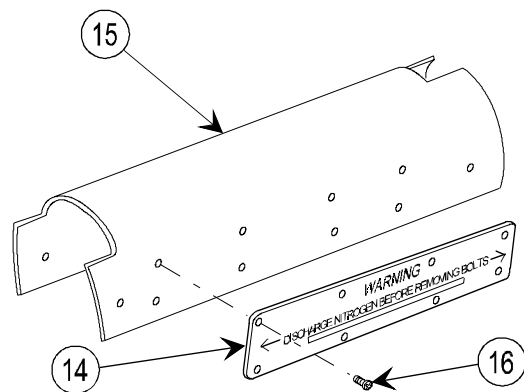

2-22. EQUILIBRATOR ASSEMBLY—MAINTENANCE INSTRUCTIONS (cont)

INSTALLATION (cont)

WARNING

Warning plate (15) must be installed on both sides of equilibrator cylinder.

NOTE

Procedure is written for only one ballistic shield, but applies to both.

- 10 Position ballistic shields (16) on equilibrator cylinder, and secure with four screws (17), four lockwashers (18) and lock wire.

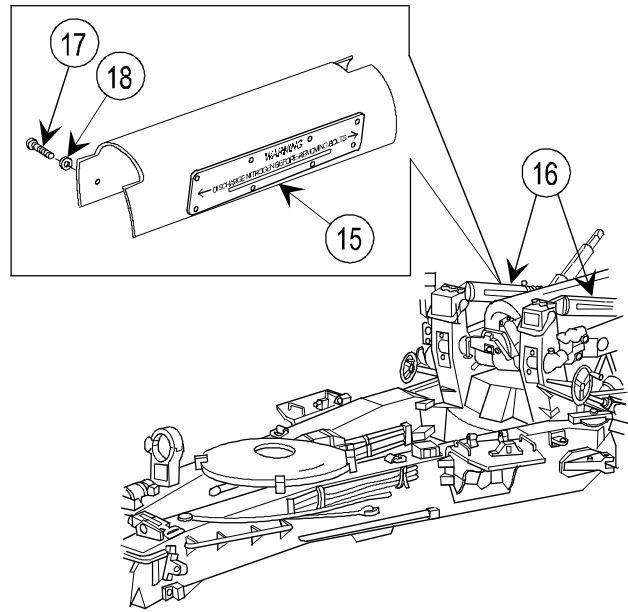

NOTE

All data on page 2-163 deleted.

2-23. CRADLE ASSEMBLY—MAINTENANCE INSTRUCTIONS

THIS TASK COVERS:

- a. Removal of clevis assembly and parts
- b. Installation of clevis assembly and parts
- c. Removal of holders and parts
- d. Installation of holders and parts
- e. Replacment of holders and parts

INITIAL SETUP

Tools and Special Tools

Artillery and turret mechanic's ordnance tool kit (SC 5180-95-CL-A12)
Artillery field maintenance shop equipment (SC 4933-95-CL-A12)
Eyebolt (MS51937-13)
Nitrogen hose assembly (12008918)
Safety strut assembly (12008900)
Seven-foot (2-m) 2- x 4-in. (5- x 10-cm) board available
3-ton hoist

Materials/Parts

Capscrew (8) (12009197)
Cotter pin (2) (MS24665-499)
Lock wire (item 35, appx B)
Lock wire (item 40, appx B)
Primer (item 20, appx B)
Primer (CARC) (item 21, appx B)

Personnel Required: 3

Artillery mechanics (2)
Welder

References

TB 9-1025-211-34
TM 9-1025-211-34P

Equipment Conditions

2-151 Equilibrator assemblies removed
2-23 M199 cannon removed
2-58 M45 recoil mechanism removed

General Safety Instructions

WARNING

All lifting devices must be checked in accordance with local Standing Operating Procedure (SOP) to make sure they are in good working condition before starting the lifting operation.

REMOVAL OF CLEVIS ASSEMBLY AND PARTS

NOTE

Cradle assembly need not be removed for repair procedures except for replacement of parts behind caps. The two nuts on clevis assembly and eyebolt may be tack welded in place. Use chisel to break tack weld prior to removal.

- 1 Remove lock wire, six bolts (1), six washers (2), two clips (3), and six inserts (4).

CAUTION

Removing threaded inserts may cause damage. Do not remove them unless necessary for replacement of authorized parts.

- 2 Remove two cotter pins (5).
- 3 Remove two nuts (6) and two washers (7).
- 4 Remove two eyebolts (8).
- 5 Remove two nuts (9), two screws (10), and two clevis (11).

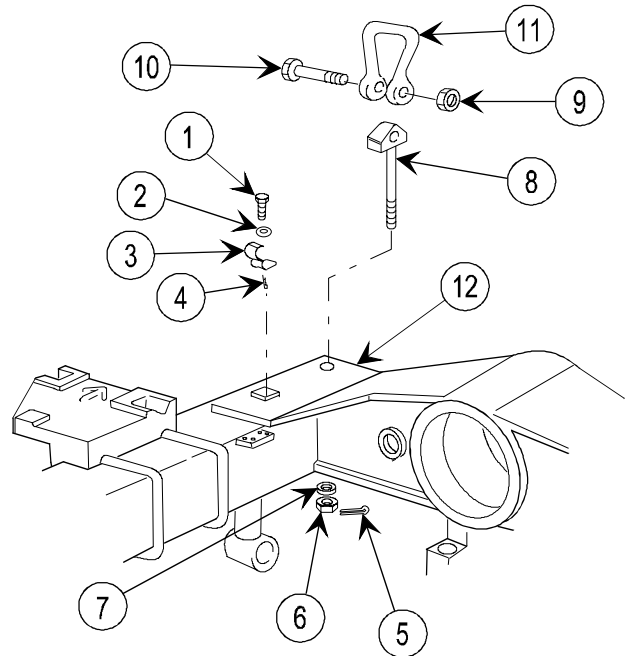

INSTALLATION OF CLEVIS ASSEMBLY AND PARTS

NOTE

Repair is by replacement of authorized parts (TM 9-1025-211-34P) as required. Nuts (1), screws (2), and clevis (3) can only be replaced as a unit; order shackle PN MS70087-3.

- 1 Install two eyebolts (4) in cradle assembly (5).
- 2 Install two clevis (3), two screws (2), and two nuts (1) on two eyebolts (4).
- 3 Install washers (6) and two nuts (7); tighten nuts, allowing free rotation of eyebolts (4).
- 4 Install two new cotter pins (8).
- 5 Tack weld nuts (7 and 1) at two locations (180 degrees apart) to eyebolt (4) and screw (2).
- 6 Install six inserts (9), two clips (10), six washers (11), six bolts (12), and lock wire (item 35, appx B).

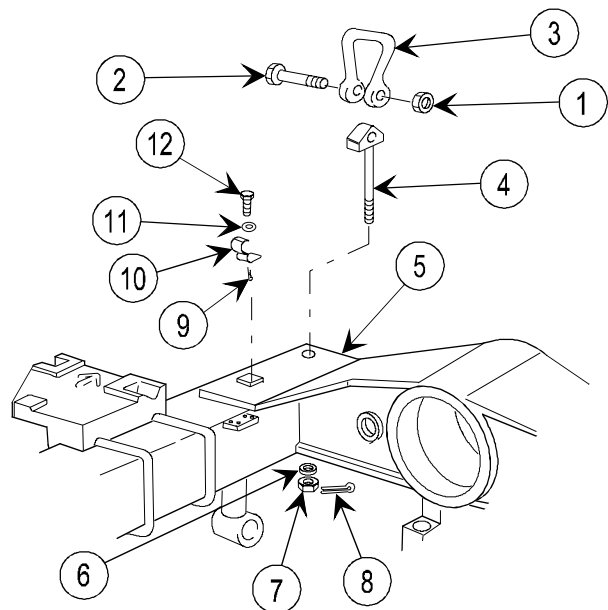

2-23. CRADLE ASSEMBLY—MAINTENANCE INSTRUCTIONS (cont)

REMOVAL OF HOLDERS AND PARTS

- 1 Remove lock wire, eight bolts (1), eight washers (2), and two holders (3).

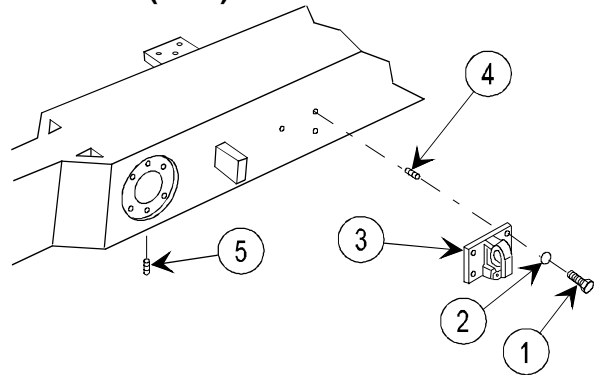

CAUTION

Removing threaded inserts may cause damage. Do not remove them unless necessary for replacement of authorized parts.

- 2 Remove eight inserts (4).
- 3 Remove insert (5).
- 4 Remove four sleeve bushings (6).
- 5 Remove two sleeve bearings (7).

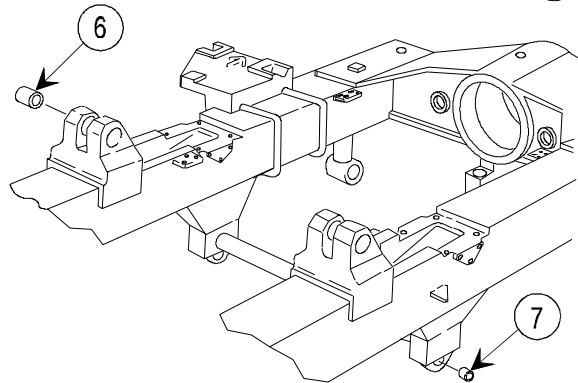

INSTALLATION OF HOLDERS AND PARTS

NOTE

Repair is by replacement of authorized parts (TM 9-1025-211-34P) or weldment of travel lock struts (TB 9-1025-211-34) as required.

- 1 Install two sleeve bearings (1).
- 2 Install four sleeve bushings (2).
- 3 Install insert (3).
- 4 Install eight inserts (4).
- 5 Install two holders (5), eight washers (6), and eight bolts (7).
- 6 Install lock wire (item 35, appx B).

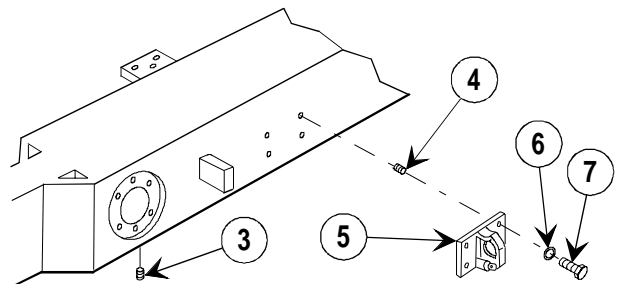
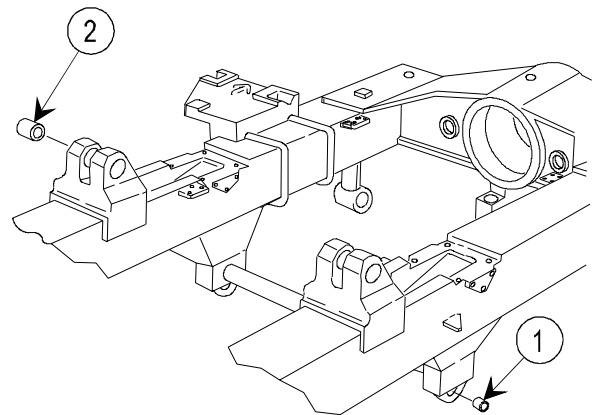

REPLACEMENT OF HOLDERS AND PARTS

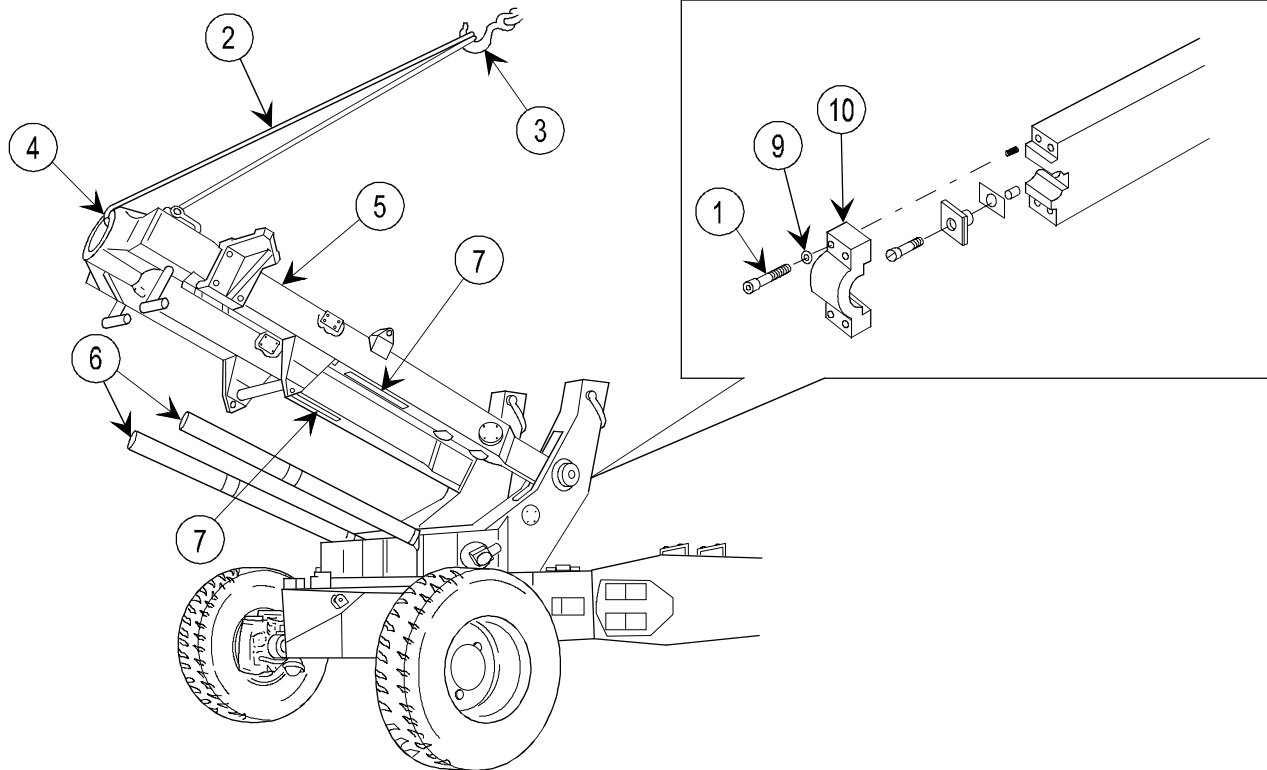

- 1 With howitzer at zero elevation, remove lock wire from eight cap screws (1).
- 2 Loosen, but do not remove eight cap screws (1).
- 3 Attach sling (2) and hoist (3) to bearing unit housing (4).
- 4 Raise cradle assembly (5) high enough to allow removal of elevating screw assemblies (6).
- 5 Remove two elevating screw assemblies (6) (p 2-191), and lower through slots (7) in cradle assembly (5); rest elevating screw assemblies against the top carriage.
- 6 Lower cradle assembly (5) onto board (8) and connect slings (2) to front and rear of cradle assembly (5).
- 7 Raise hoist (3), removing slack from slings (2), and remove board (8).

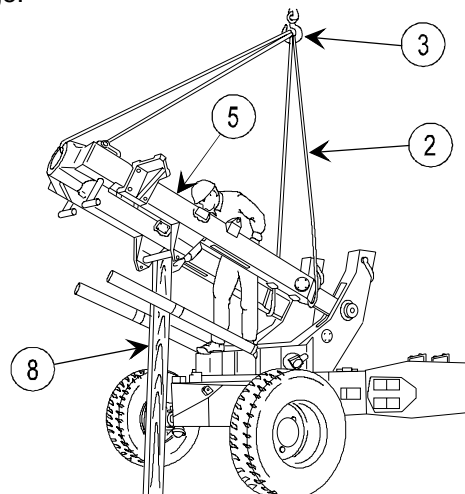

2-23. CRADLE ASSEMBLY—MAINTENANCE INSTRUCTIONS (cont)

REPLACEMENT OF HOLDERS AND PARTS (cont)

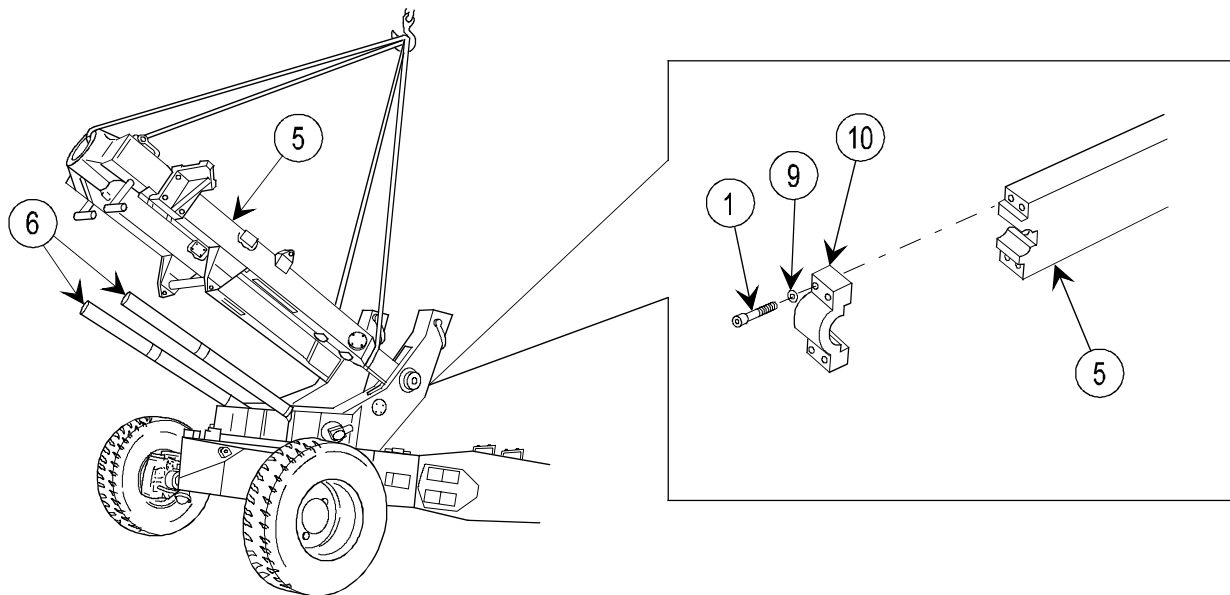

8 Lower cradle assembly (5), stopping just before cradle assembly reaches the two elevating screw assemblies (6).

9 Remove eight cap screws (1), washers (9), and two caps (10). Discard eight cap screws.

10 Lift cradle assembly (5) clear of top carriage. Place cradle assembly (5) on supports.

11 Remove inserts (11), only if damaged.

12 Remove two cap screws (12), two inserts (13), and two shims (14).

13 Remove two inserts (15), only if damaged.

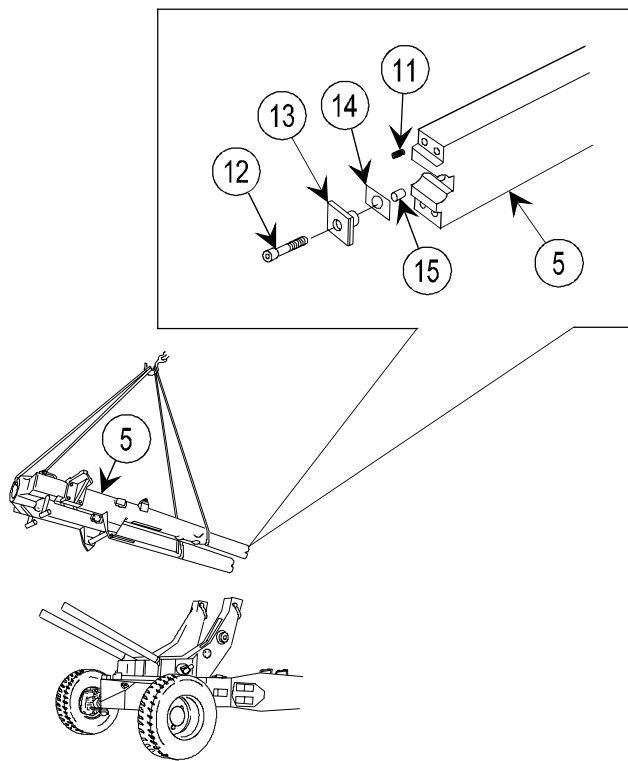

NOTE

If cradle assembly (5) is being replaced continue with step 14; if the same cradle assembly will be assembled to the top carriage, proceed to step 19.

The illustration below is a cutaway view of the trunnions located in the top carriage assembly. Measure trunnion dimension "A", then cradle assembly dimension "B". Adjust shims as required to obtain proper fit when cradle assembly is assembled to the top carriage.

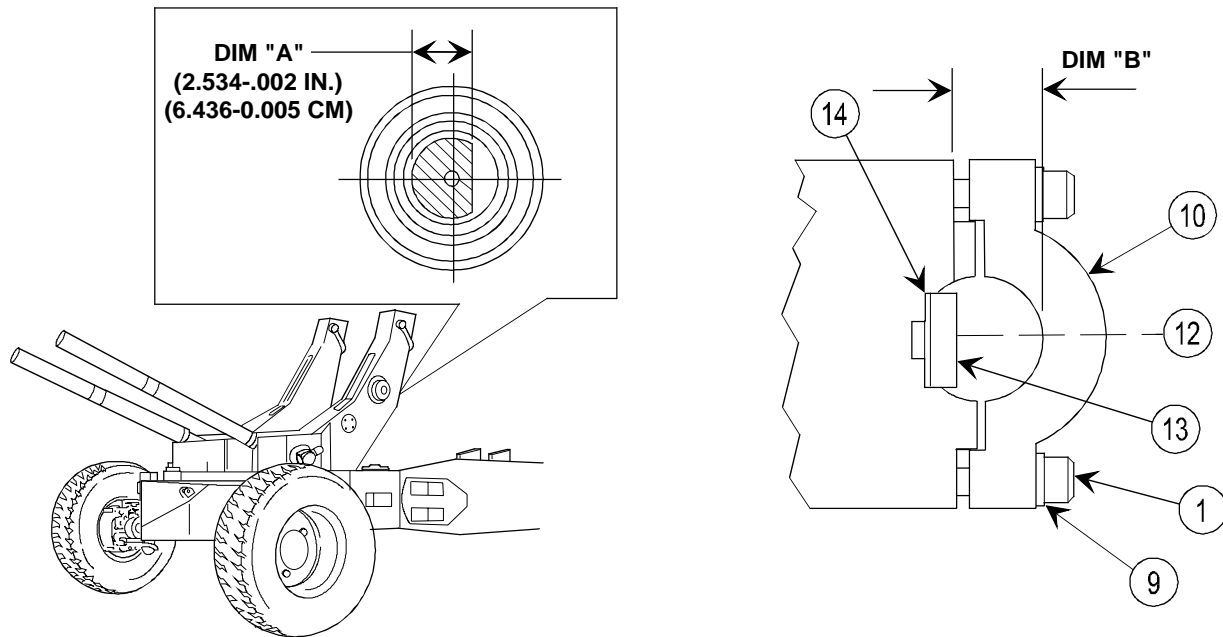

- 14 Measure trunnion diameter, located on top carriage upright, across the flat machined surface. This dimension should be 2.534 to 0.002 in. (6.436 to 0.005 cm).
- 15 Assemble two shims (14), two inserts (13), and two capscrews (12). Torque capscrews (12) to 70 to 80 in.-lb (8 to 9 N-m).
- 16 Assemble two caps (10), eight washers (9), and eight capscrews (1); torque capscrews (12) to 150 to 160 ft-lb (202 to 216 N-m).
- 17 Measure the inside dimension of cradle assembly from the flat created by insert (13) to the radius created by the cap (10). This dimension should be 0.001 to 0.004 in. (0.003 to 0.010 cm) smaller than the diameter of the trunnion. Adjust shim (14) to obtain the required dimension. Following these procedures will allow the correct cradle-to-trunnion fit.

NOTE

Caps (10) are not interchangeable; mark caps to ensure they are assembled to the same end of the cradle assembly.

2-23. CRADLE ASSEMBLY—MAINTENANCE INSTRUCTIONS (cont)

REPLACEMENT OF HOLDERS AND PARTS (cont)

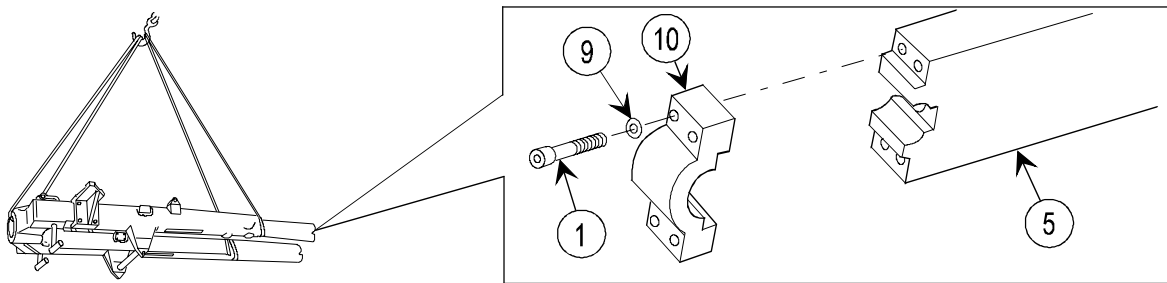

- 18 Remove eight capscrews (1), eight washers (9), and two caps (10) from cradle assembly (5). Discard capscrews.

NOTE

Repair is by replacement of authorized parts (TM 9-1025-211-34P) as required. Inserts (11 and 15) and holes must be coated with primer at time of installation.

- 19 Install two inserts (15), if removed.
- 20 Install two shims (14), two inserts (11), and two capscrews (12). Torque capscrews (12) to 70 to 80 in.-lb (8 to 9 N-m).
- 21 Install eight inserts (11), if removed.

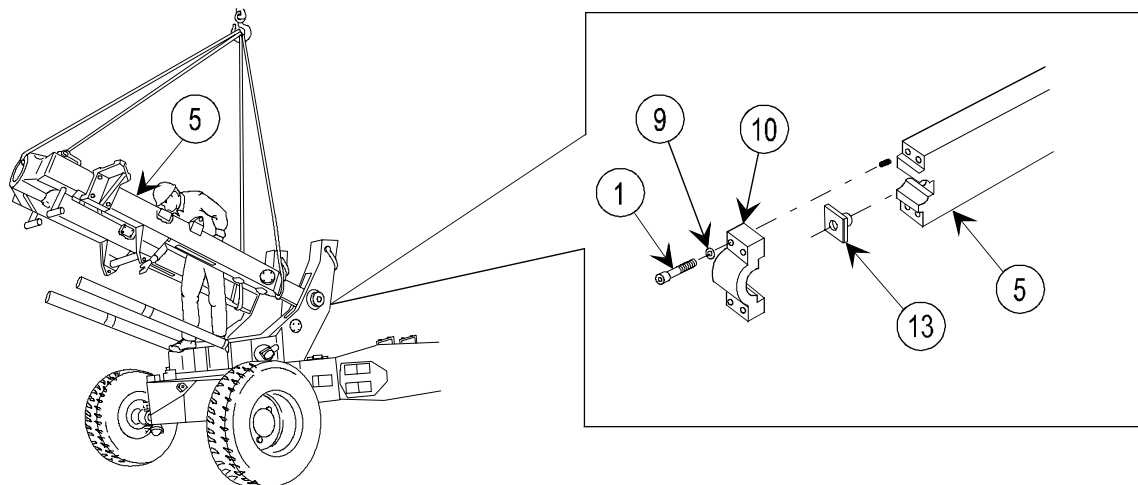
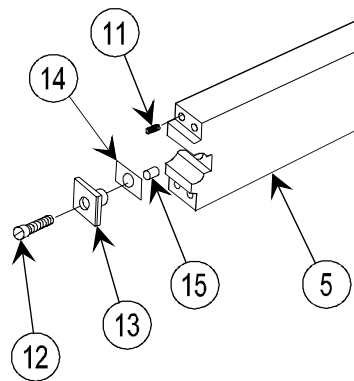

- 22 Position cradle assembly (5) to top carriage and align end of cradle assembly (5) to the trunnions. Ensure that flats formed by shims (13) are aligned with flats on trunnions.
- 23 Install two caps (10), eight washers (9), and eight new capscrews (1). Cradle assembly may have to be lowered to install and handtighten new capscrews (1).

- 24 Place board (8) under cradle assembly (5) and remove rear sling (2). Raise cradle assembly high enough to install two elevating screw assemblies (6).
- 25 Position two elevating screw assemblies (6) under slots (7) and lower cradle assembly (5) over the elevating screw assemblies.
- 26 Install elevating screw assemblies (6) to cradle assembly (p 2-191).
- 27 Remove sling (2) and 3-ton hoist (3).

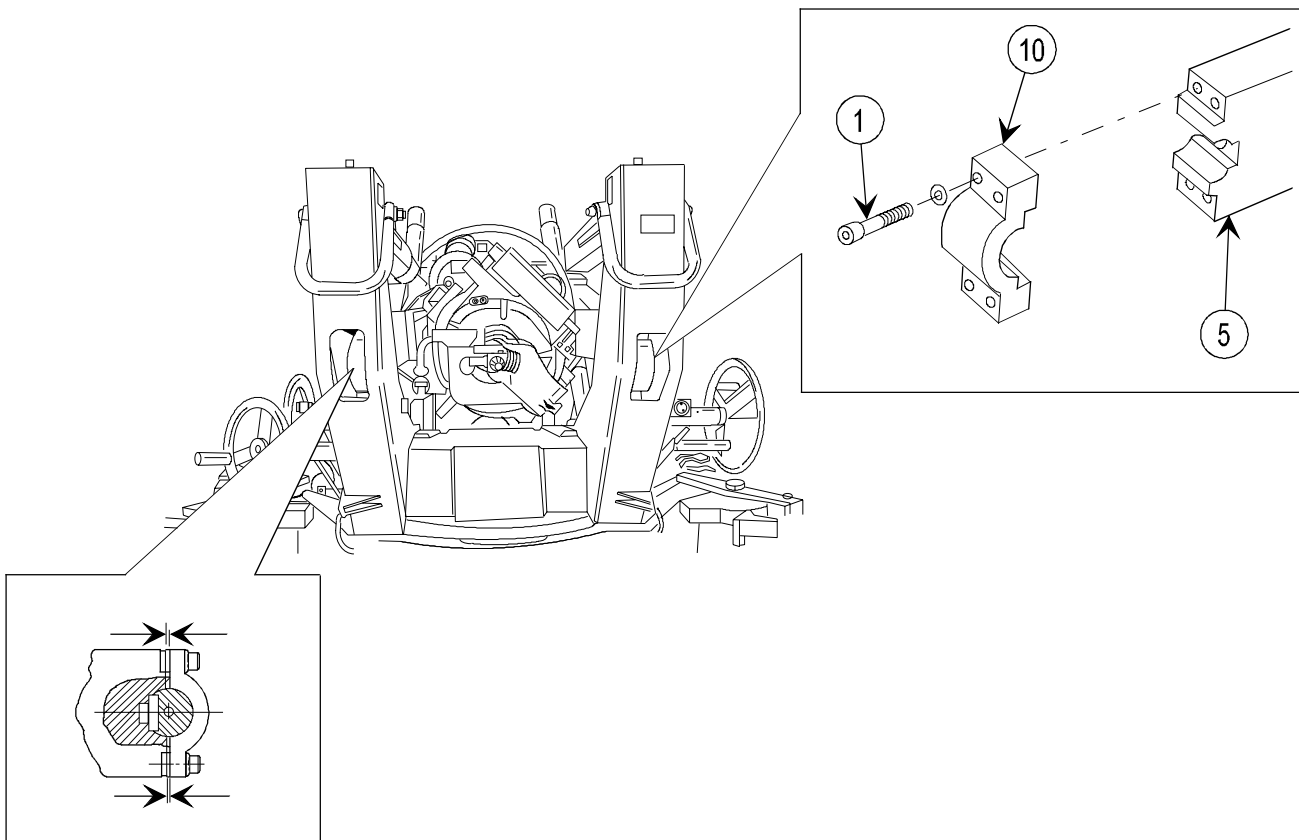
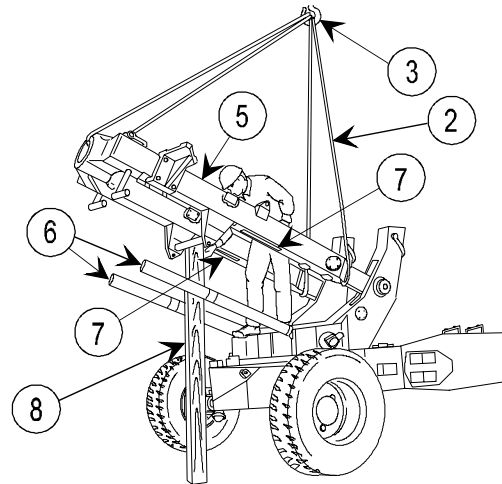

- 28 Lower cradle assembly (5) to gain access to caps (10) and torque eight cap screws (1) in increments of 15 to 20 ft-lb (20 to 27 N-m) using a cross-torque pattern until 150 to 160 ft-lb (202 to 216 N-m) is obtained.

NOTE

When torque is applied to cap screws, ensure equal space is maintained between cap (10) and end of cradle assembly (5).

- 29 Install lock wire (item 40, appx B) to eight cap screws (1).

2-24. BEARING UNIT HOUSING—MAINTENANCE INSTRUCTIONS

THIS TASK COVERS:

- | | | |
|---------------|-----------------|----------------------|
| a. Removal | b. Disassembly | c. Inspection/repair |
| d. Reassembly | e. Installation | |

INITIAL SETUP

Tools and Special Tools

Artillery and turret mechanic's ordnance tool kit (SC 5180-95-CL-A12)

Materials/Parts

Cleaning compound (item 7, appx B)

WTR grease (item 11, appx B)

References

TM 9-1025-211-10 (appx F)

TM 9-1025-211-34P

Equipment Conditions

2-23 Cannon tube centered in bearing unit housing

2-42 Muzzle brake removed

REMOVAL

- 1 Remove four machine screws (1).
- 2 Remove four flat washers (2).
- 3 Install four machine screws (1) in the threaded holes in the bearing unit housing (3).
- 4 Remove bearing unit housing (3) by tightening four machine screws (1) alternately until bearing unit housing is loose.

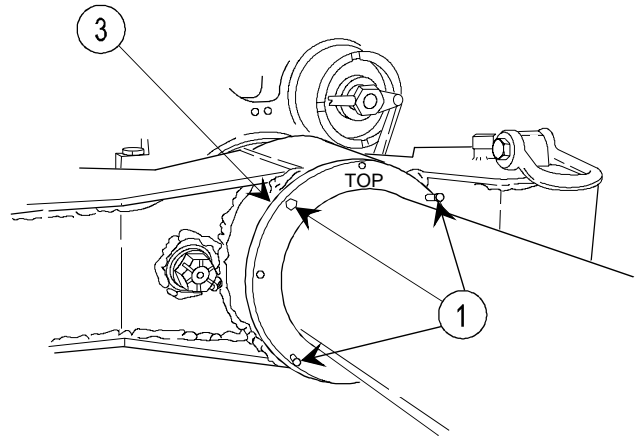
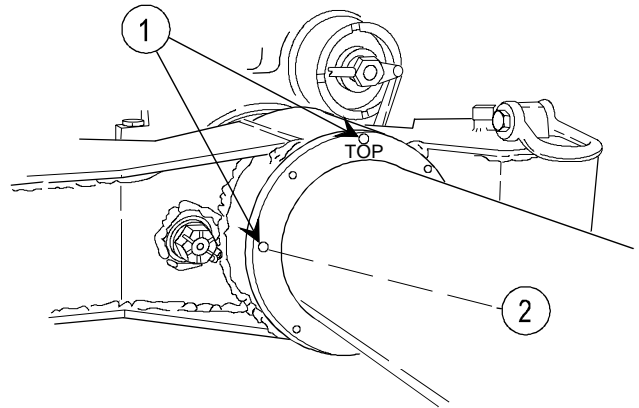

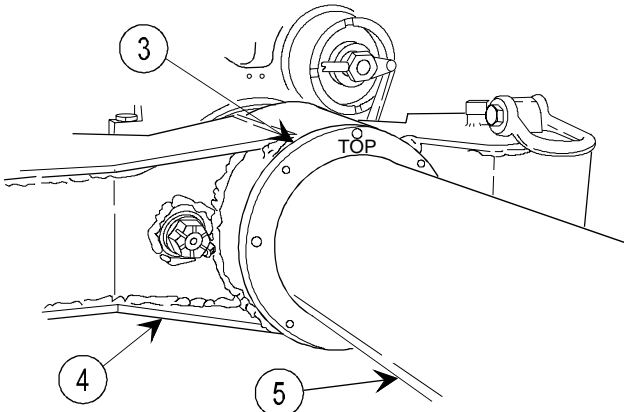

- 5 Slide bearing unit housing (3) out of front of cradle assembly (4) and off cannon tube (5).

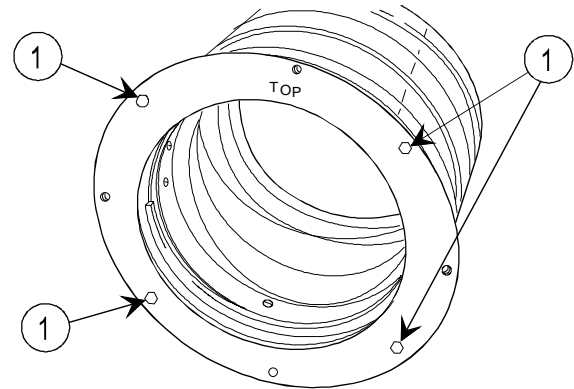

- 6 Remove four machine screws (1).

CAUTION

Removing threaded inserts may cause damage. Do not remove them unless necessary for replacement of authorized parts.

- 7 Remove four inserts (6).

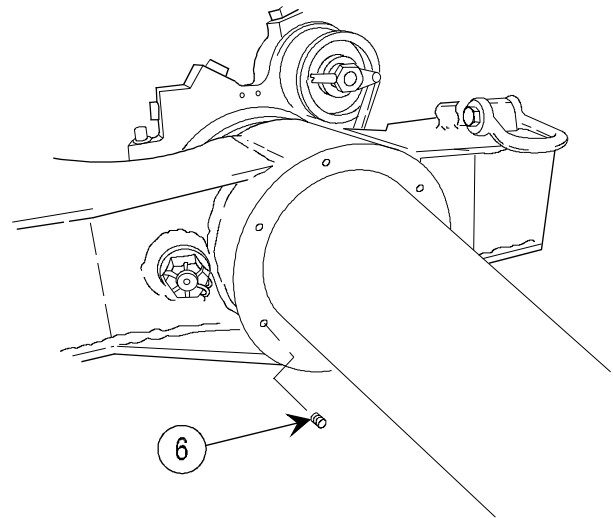

DISASSEMBLY

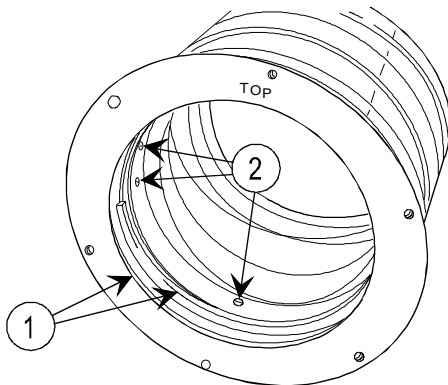

- 1 Pry up and remove two wiper rings (1).
2 Remove ten machine screws (2).

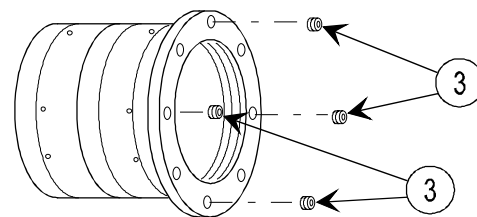

CAUTION

Removing threaded inserts may cause damage. Do not remove them unless necessary for replacement of authorized parts.

- 3 Remove four threaded inserts (3).

2-24. BEARING UNIT HOUSING—MAINTENANCE INSTRUCTIONS (cont)

DISASSEMBLY (cont)

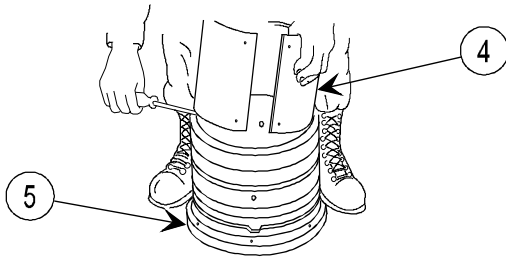

- 4 Pry up on sleeve bearing (4), and remove from support assembly (5).

REASSEMBLY

- 1 Install sleeve bearing (1), making sure the mounting holes are aligned with those in the support assembly (2).
- 2 Install ten machine screws (3) and tighten.
- 3 Install two wiper rings (4).
- 4 Install four inserts (5).
- 5 Install four inserts (6).
- 6 Apply WTR grease to inner surface of sleeve bearing (1).

INSTALLATION

NOTE

Ensure two fittings align with holes in cradle assembly. Replace bearing unit housing (TM 9-1025-211-34P) if damaged beyond repair.

- 1 Install bearing unit housing (1) with word TOP facing up.
- 2 Install four flat washers (2).
- 3 Install and tighten four machine screws (3).
- 4 Lubricate bearing unit housing (1) according to TM 9-1025-211-10, appx F.

INSPECTION/REPAIR

- 1 Check for any broken, damaged, or missing parts.
- 2 Clean support assembly with cleaning compound. Ensure grease access holes are clear.
- 3 Repair is by replacement of authorized parts (TM 9-1025-211-34P).

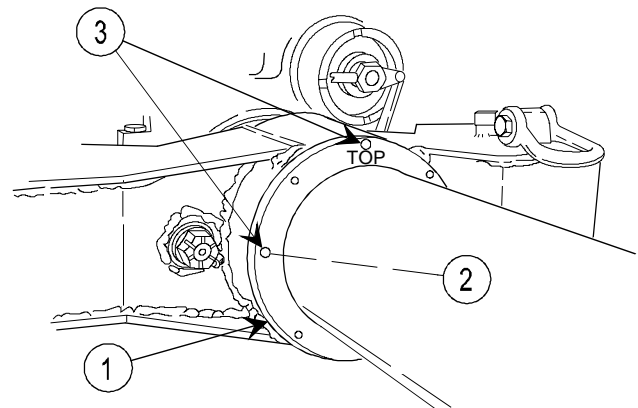
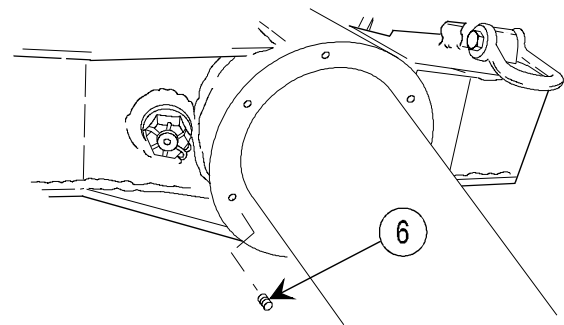
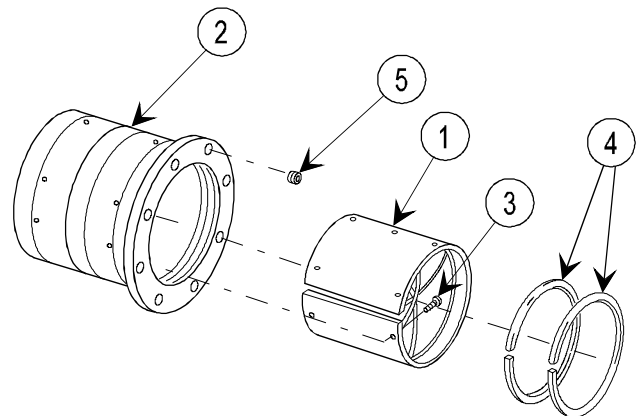

2-25. REST ASSEMBLY—MAINTENANCE INSTRUCTIONS

THIS TASK COVERS:

- | | | |
|---------------|-----------------|----------------------|
| a. Removal | b. Disassembly | c. Inspection/repair |
| d. Reassembly | e. Installation | |

INITIAL SETUP

Tools and Special Tools

Artillery and turret mechanic's ordnance tool kit (SC 5180-95-CL-A12)

Safety strut assembly (12008900)

Materials/Parts

Cleaning compound (item 7, appx B)

Primer (item 20, appx B)

Ring (12007969)

Seal (8437201-2)

WTR grease (item 11, appx B)

References

TM 9-1025-211-34P

Equipment Conditions

2-23 Cannon tube removed

2-23 Safety strut assemblies installed

REMOVAL

WARNING

Failure to install safety strut assemblies can result in injury or damage to equipment.

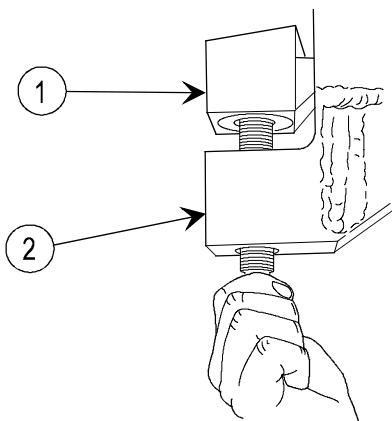

- 1 Unscrew rest assembly (1) from cradle assembly (2).

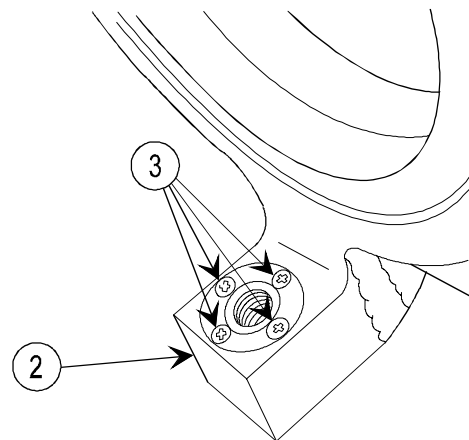

- 2 Remove four machine screws (3) from cradle assembly (2).

2-25. REST ASSEMBLY—MAINTENANCE INSTRUCTIONS (cont)

REMOVAL (cont)

- 3 Remove sleeve nut (4) from cradle assembly (2).

CAUTION

Removing threaded inserts may cause damage. Do not remove them unless necessary for replacement of authorized parts.

- 4 Remove four threaded inserts (5).

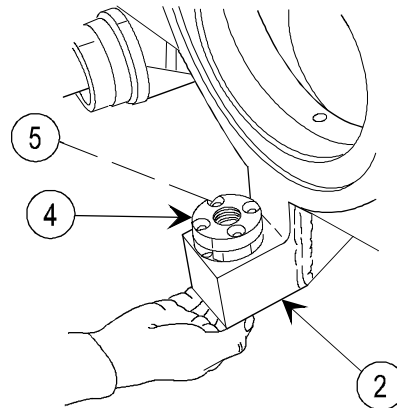

DISASSEMBLY

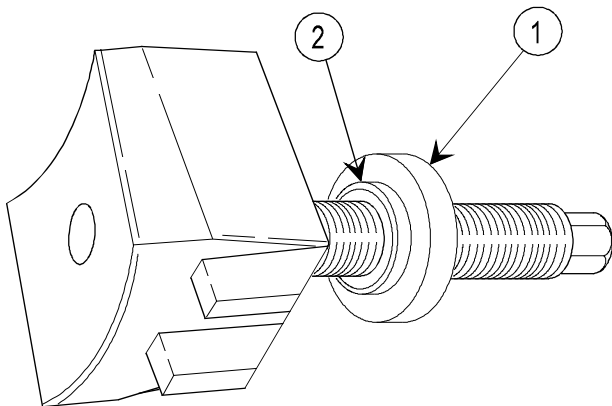

- 1 Unscrew ring (1) and remove.
- 2 Remove seal (2) from ring (1).

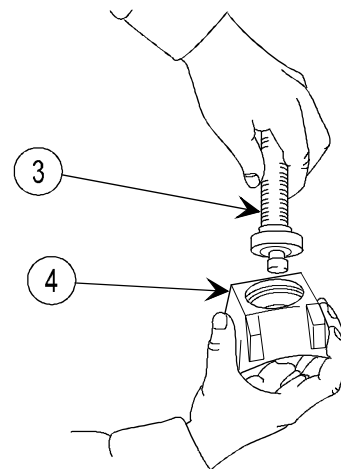

- 3 Remove shoulder screw (3) from rest (4).

- 4 Remove washer bearing (5), retainer and roller (6), and washer bearing (7) from shoulder screw (3).

NOTE

Roller bearing (8) may be in rest (4) or on shoulder screw (3).

- 5 Remove roller bearing (8).

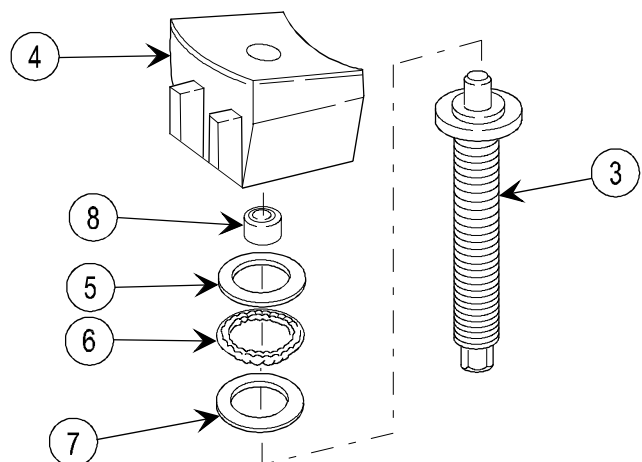

INSPECTION/REPAIR

- 1 Check for broken, damaged, or missing parts.
- 2 Clean parts with cleaning compound and lubricate with WTR grease.
- 3 Repair is by replacement of authorized parts (TM 9-1025-211-34P).

REASSEMBLY

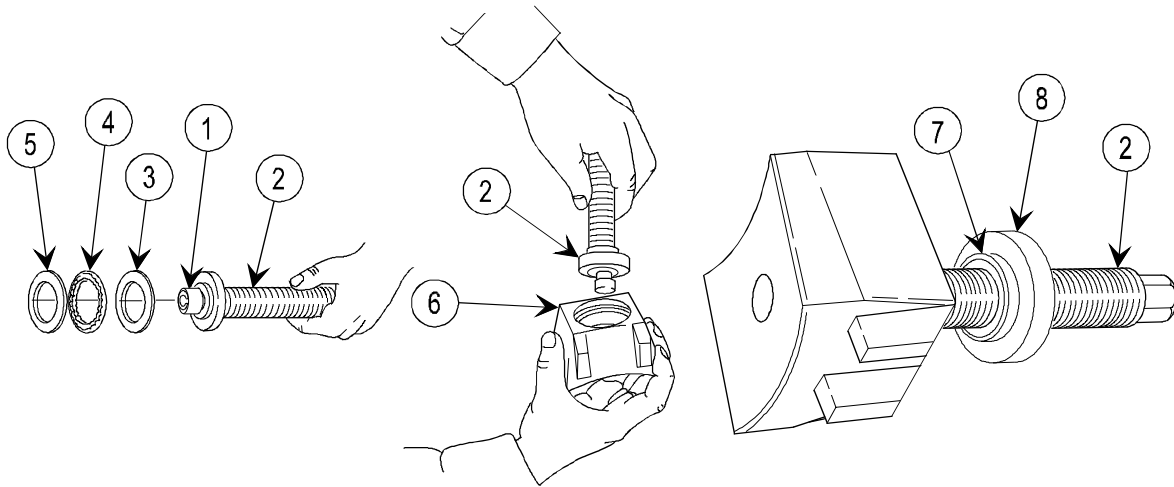

- 1 Place roller bearing (1) on shoulder screw (2).
- 2 Install washer bearing (3), retainer and roller (4), and washer bearing (5) on shoulder screw (2).
- 3 Place shoulder screw (2) in rest (6).
- 4 Install new seal (7) in new ring (8).
- 5 Screw ring (8) onto shoulder screw (2). Tighten until there is no end play and shoulder screw turns freely; then stake in place.

INSTALLATION

- 1 Coat four threaded inserts (1) and mating holes with primer and install while primer is wet.
- 2 Install sleeve nut (2).
- 3 Install four machine screws (3).
- 4 Screw rest assembly (4) into cradle assembly (5).

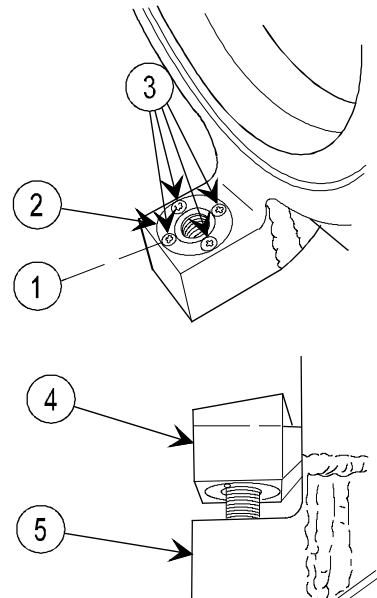

2-26. GUIDE ASSEMBLY—MAINTENANCE INSTRUCTIONS

THIS TASK COVERS:

- a. Removal
- b. Disassembly
- c. Inspection/repair
- d. Reassembly
- e. Installation

INITIAL SETUP

Tools and Special Tools

Artillery and turret mechanic's ordnance tool kit (SC 5180-95-CL-A12)
Artillery field maintenance shop equipment (SC 4933-95-CL-A12)
Safety strut assembly (12008900)

Materials/Parts

Cleaning compound (item 7, appx B)
Laminated shim (12009359)
Lock wire (item 34, appx B)
Primer (item 20, appx B)
WTR grease (item 11, appx B)

References

TM 9-1025-211-10 (appx F)
TM 9-1025-211-34P

Equipment Conditions

2-23 M199 cannon removed
2-58 M45 recoil mechanism removed

REMOVAL

NOTE

Procedures are written for only one guide assembly, but apply to both.

- 1 Remove lock wire (1) and two bolts (2).
- 2 Unscrew cap (3) and remove.
- 3 Remove guide assembly (4).

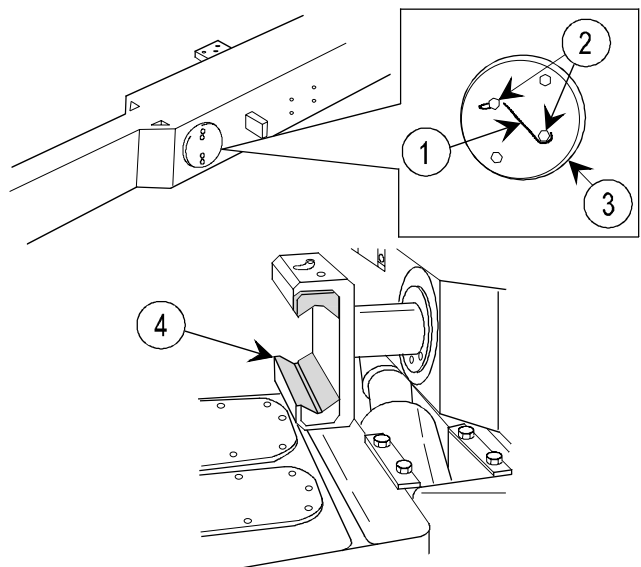

DISASSEMBLY

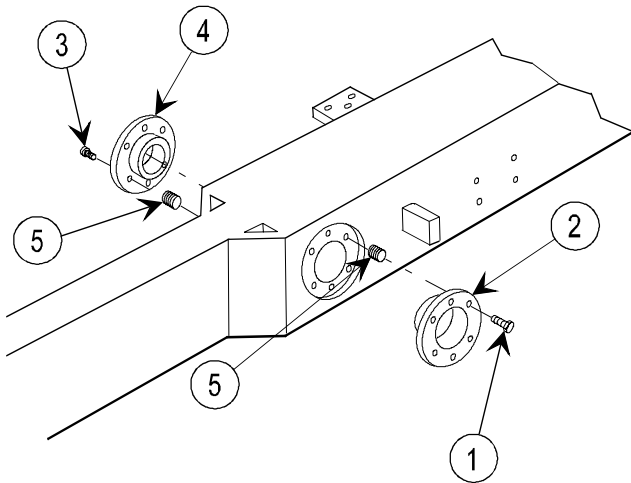

- 1 Remove six machine screws (1), outer sleeve bearing (2), six machine screws (3), and inner sleeve bearing (4).

CAUTION

Removing threaded inserts may cause damage. Do not remove them unless necessary for replacement of authorized parts.

- 2 Remove 12 threaded inserts (5), six from each side of the cradle assembly.
- 3 Remove eight capscrews (6), eight lockwashers (7), and eight flat washers (8).
- 4 Remove top guide (9) and bottom guide (10).

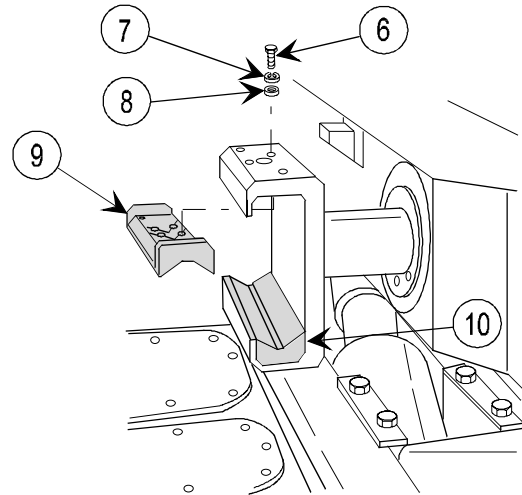

INSPECTION/REPAIR

- 1 Clean parts with cleaning compound.
- 2 Check the cradle guide for damage; i.e., for cracked, broken, or missing parts. Replace if necessary.
- 3 Repair is by replacement of authorized parts (TM 9-1025-211-34P).

REASSEMBLY

- 1 Position top guide (1) and bottom guide (2) in guide (3).
- 2 Install eight flat washers (4), eight lockwashers (5), and eight capscrews (6). Tighten.

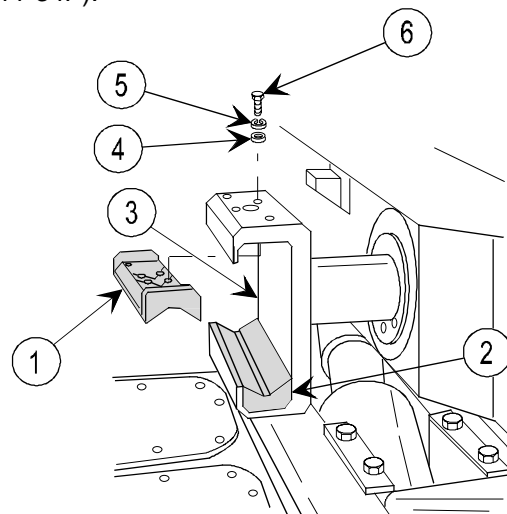

2-26. GUIDE ASSEMBLY—MAINTENANCE INSTRUCTIONS (cont)

REASSEMBLY (cont)

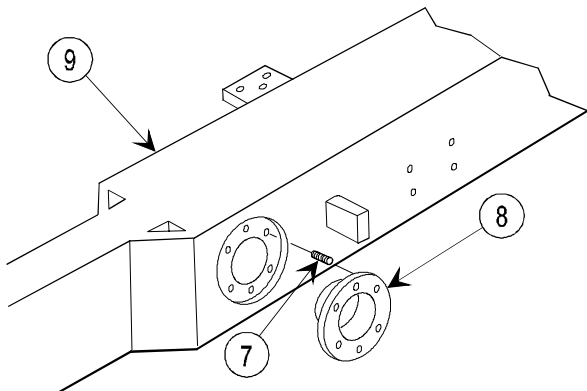

- 3 Coat 12 threaded inserts (7) and mating holes with primer and install threaded inserts while primer is wet.
- 4 Position outer sleeve bearing (8) over mounting holes in cradle assembly (9).

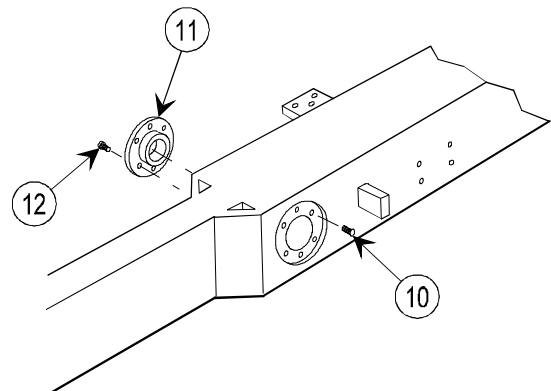

- 5 Install six machine screws (10) and stake in place.
- 6 Position inner sleeve bearing (11) on mounting studs.
- 7 Install six machine screws (12) and stake in place.

INSTALLATION

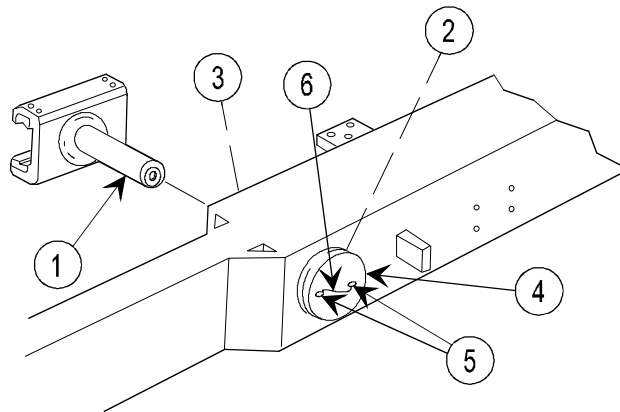

NOTE

Replace guide assemblies (TM 9-1025-211-34P) if damaged beyond repair or if guide shaft is bent or broken.

Illustration is for right guide assembly. Shim will be for left guide assembly only.

- 1 Lubricate guide assembly (1) according to TM 9-1025-211-10.
- 2 Install guide assembly (1) through sleeve bearings (2 and 3).

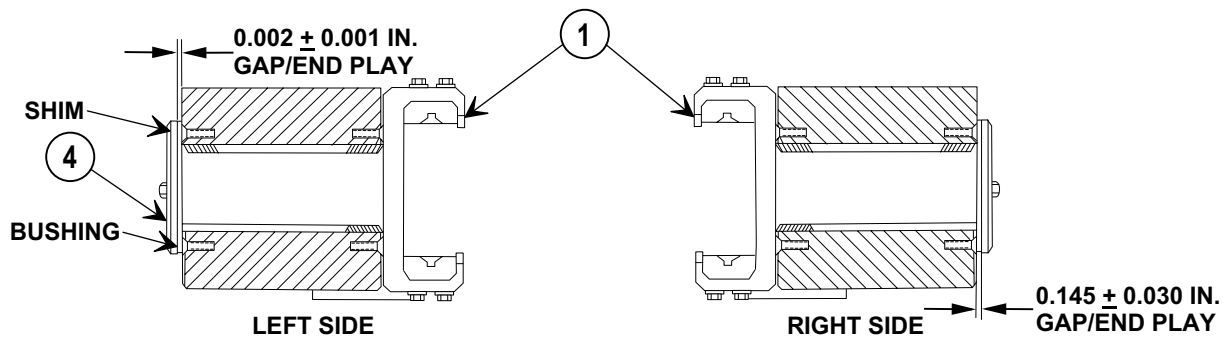

- 3 To determine the rail guide clearances, perform the following:
 - a. Left Side (0.001 - 0.003 in. (0.025 - 0.076 mm) Gap/End Play): With guide assembly (1) installed, place complete shim(s) (12009359) over threads of cap (4) and install cap and shim completely into guide assembly. Measure gap between cap and bushing (12007976), using magnetic base dial indicator or feeler gauge stock. Subtract 0.002 in. (0.051 mm) from this dimension; the result is amount of laminated shim stock that needs to be removed from shim.

Disassemble cap (4) and shim from guide assembly (1) and peel away laminated layers of shims until needed thickness is obtained. Reassemble and check for required clearance of 0.001 - 0.003 in. (0.025 - 0.076 mm).
 - b. Right Side (0.115 - 0.175 in. (2.9 - 4.4 mm) Gap/End Play): With guide assembly (1) installed, install cap (4) and thread into guide assembly until gap/end play within the required tolerance is obtained and two bolts (5) can be installed.
- 4 Install two bolts (5) and tighten, and install lock wire (6).

2-27. ELEVATING HANDWHEEL—MAINTENANCE INSTRUCTIONS (cont)

INSTALLATION

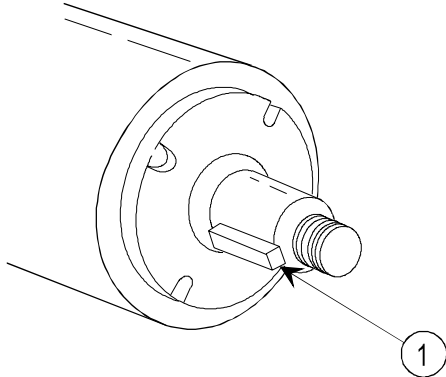

1 Install machine key (1).

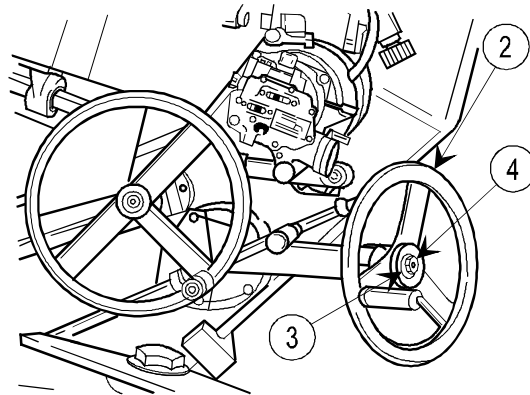

2 Install elevating handwheel (2).

3 Install flat washer (3) and nut (4); torque 20 + 5 ft-lb (27 + 7 N-m).

2-28. ELEVATING ANGLE DRIVE UNIT—MAINTENANCE INSTRUCTIONS

THIS TASK COVERS:

- | | | |
|---------------|-----------------|----------------------|
| a. Removal | b. Disassembly | c. Inspection/repair |
| d. Reassembly | e. Installation | f. Service |

INITIAL SETUP

Tools and Special Tools

- Artillery and turret mechanic's ordnance tool kit (SC 5180-95-CL-A12)
- Artillery field maintenance shop equipment (SC 4933-95-CL-A12)
- Dial indicator (MIL-I-18422)
- M198 field artillery repairman tool kit (5911278)
- Surface gage (GGG-G-17)

Materials/Parts

- Gasket (2) (12007999)
- Laminated shim (4) (12009015)
- Laminated shim (2) (12009016)
- Laminated shim (12009019)
- Primer (item 20, appx B)
- Seal (2) (12007893)
- Sealing compound (item 25, appx B)
- Shim (2) (12008996)
- Wiping rag (item 22, appx B)
- WTR grease (item 11, appx B)

References

- Deleted
- TM 9-1025-211-34P

Equipment Conditions

- 2-181 Elevating handwheel removed

REMOVAL

NOTE

There are two elevating angle drive units, but procedures are written for one.

CAUTION

Care should be taken not to damage inserts when removing six bolts (1).

- 1 Loosen six bolts (1), then pull out on elevating angle drive unit (2) to provide clearance for removal of six bolts. Remove six bolts (1), six lockwashers (3), and six flat washers (4).
- 2 Remove elevating angle drive unit (2), shim (5), and gasket (6).

CAUTION

Removing threaded inserts may cause damage. Do not remove them unless necessary for replacement of authorized parts.

- 3 Remove four threaded inserts (7) and two threaded inserts (8).

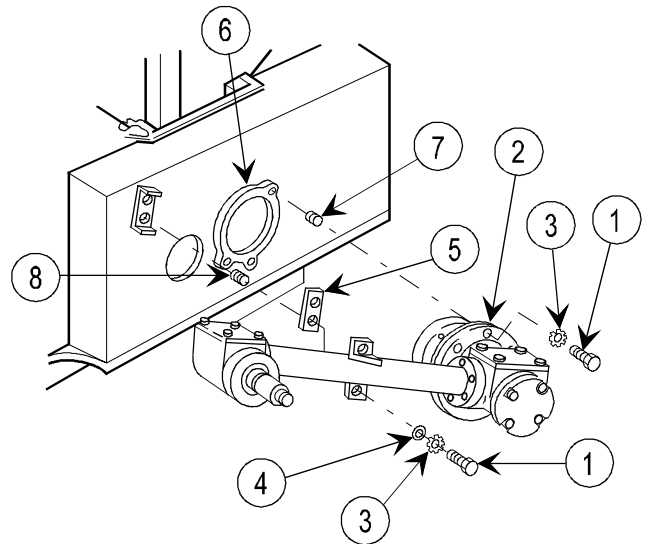

DISASSEMBLY

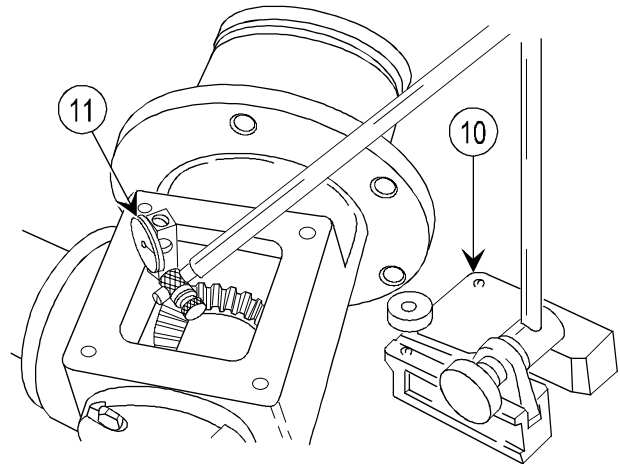
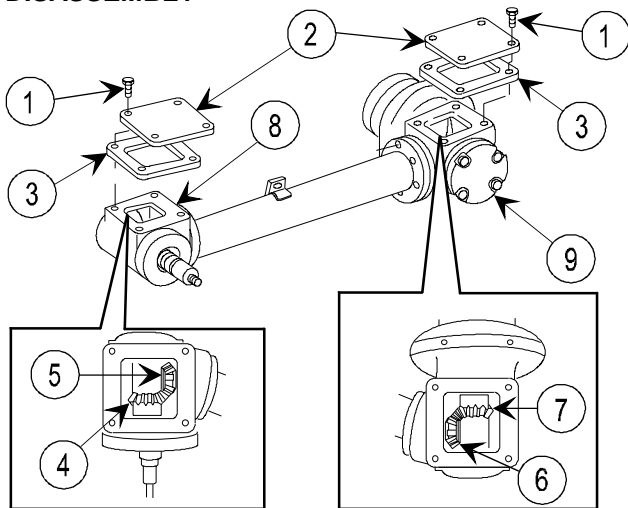

NOTE

Throughout the disassembly procedure, instructions are given to measure and record backlash and shim thickness. These measurements are taken for reference purposes for reassembly and replacement of laminated shims.

- 1 Remove eight self-locking screws (1), two access covers (2), and two gaskets (3).
- 2 Measure bevel gears (4 thru 7) and record backlash between bevel gears (4 and 5) inside upper mechanical housing (8) and bevel gears (6 and 7) inside lower mechanical housing (9) with surface gage (10) and dial indicator (11).

2-28. ELEVATING ANGLE DRIVE UNIT—MAINTENANCE INSTRUCTIONS (cont)

DISASSEMBLY (cont)

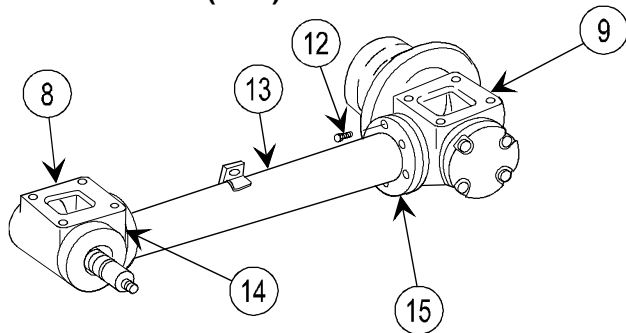

3 Remove twelve self-locking screws (12).

NOTE

Scribe reference lines on upper and lower mechanical housings and housing prior to disassembly to assist in reassembly.

4 Separate upper mechanical housing (8) from housing (13).

5 Separate lower mechanical housing (9) from housing (13).

6 Remove two shims (14 and 15). Measure and record thickness.

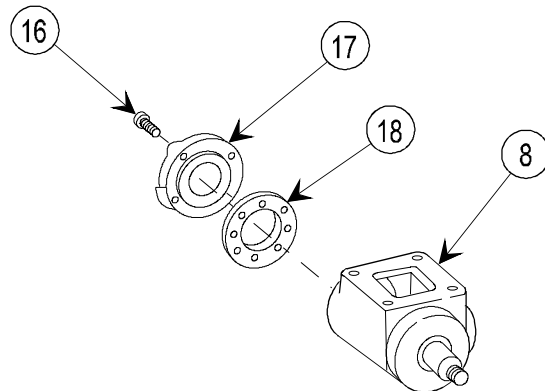

NOTE

Steps 7 thru 12 are written for the upper mechanical housing (8), but also apply to the lower mechanical housing.

7 Remove four self-locking screws (16) and access cover (17).

8 Remove shim (18). Measure and record thickness.

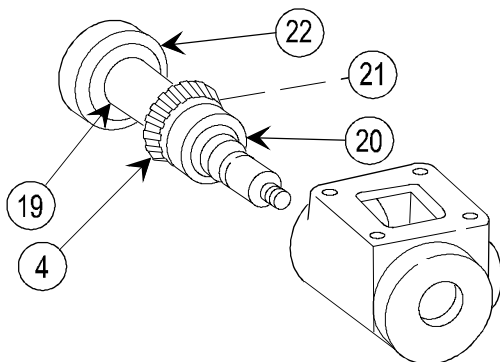

NOTE

If both mechanical housings are being disassembled, tag bevel gears, shouldered shaft, annular ball bearings, and mechanical housings to identify them for reassembly as sets.

9 Remove shouldered shaft (19), annular ball bearing (20), bevel gear (4), woodruff key (21), and annular ball bearing (22) as an assembly.

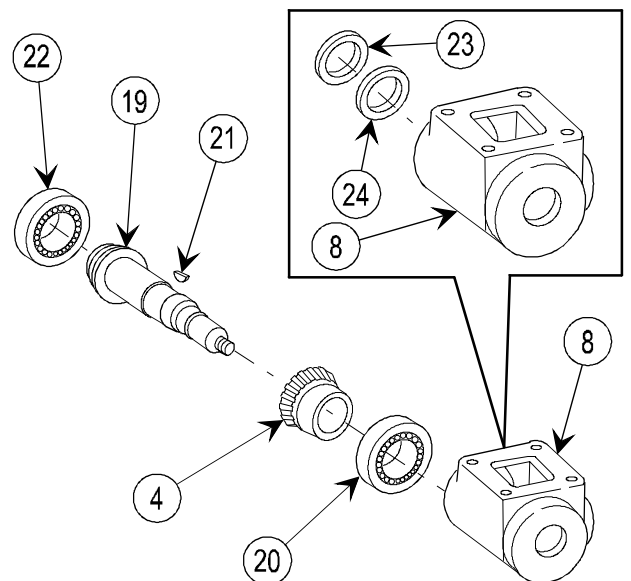

10 Remove annular ball bearings (20) and (22) from shouldered shaft (19).

11 Remove bevel gear (4) and woodruff key (21) from shouldered shaft (19).

12 Remove laminated shim (23) and seal (24) from upper mechanical housing (8).

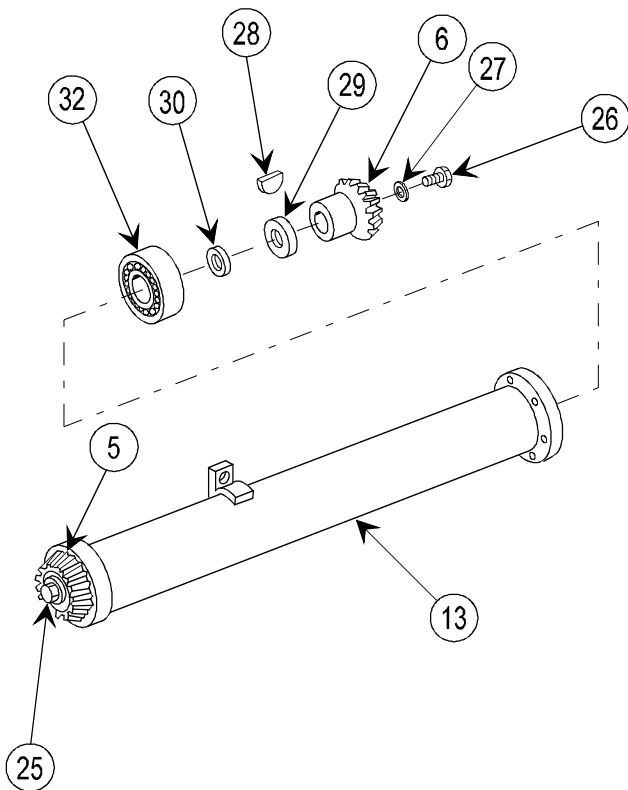

CAUTION

When using vise to secure bevel gear (5), use wiping rag to protect gears from damage in vise.

NOTE

Tag bevel gear, washer, annular ball bearing, and housing to identify location for reassembly.

Use vise to secure bevel gear (5) or hold self-locking bolt (25) on housing (13) when performing step 13.

- 13 Remove self-locking bolt (26) and flat washer (27).
- 14 Remove bevel gear (6) and woodruff key (28).
- 15 Remove washer (29) and laminated shim (30).

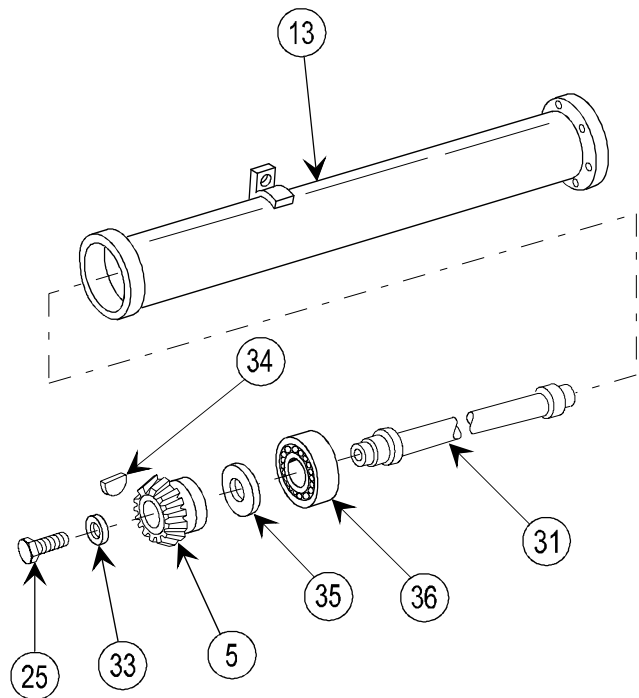

- 16 Drive shouldered shaft (31) and attached parts from housing (13). Remove annular ball bearing (32).

NOTE

Tag bevel gear, washer, and annular ball bearing to identify location for reassembly.

- 17 Secure shouldered shaft (31) and remove self-locking bolt (25), flat washer (33), bevel gear (5), woodruff key (34), washer (35), and annular ball bearing (36).

INSPECTION/REPAIR

- 1 Check for any broken, damaged, or missing parts.
- 2 Repair is by replacement of authorized parts (TM 9-1025-211-34P).

2-28. ELEVATING ANGLE DRIVE UNIT—MAINTENANCE INSTRUCTIONS (cont)

REASSEMBLY

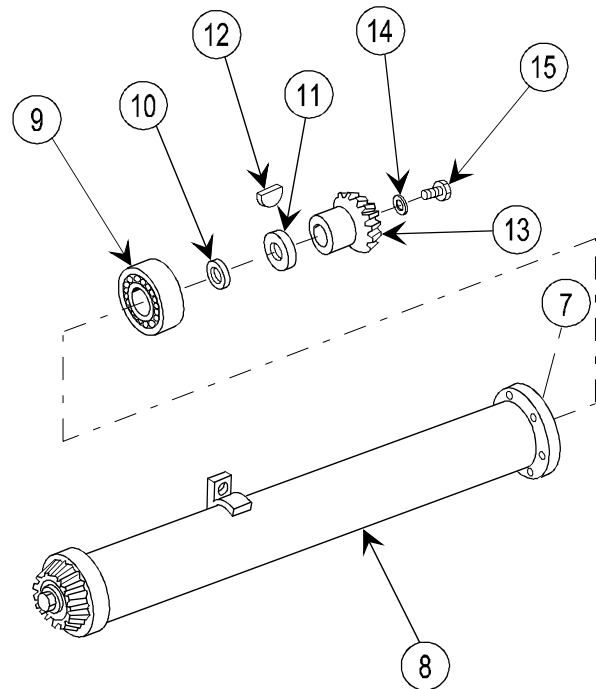
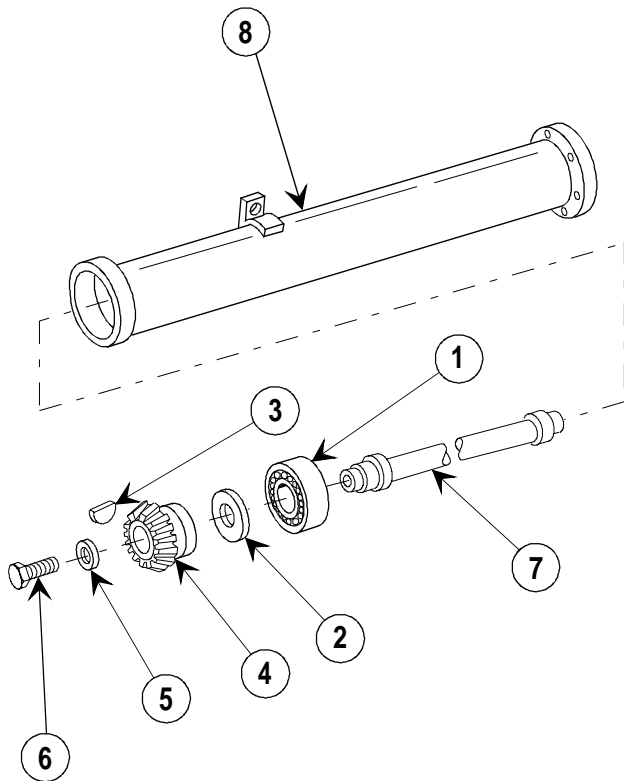

NOTE

Prior to reassembly pack all annular ball bearings with WTR grease.

- 1 Install annular ball bearing (1), washer (2), woodruff key (3), bevel gear (4), flat washer (5), and self-locking bolt (6) on the ridged upper end of shouldered shaft (7). Torque self-locking bolt (6) to 120 to 132 in.-lb (13.6 to 14.9 N-m).
- 2 Install shouldered shaft (7) with attached parts in housing (8).

- 3 Install annular ball bearing (9) onto shouldered shaft (7) until annular ball bearing seats in housing (8).

NOTE

Adjust laminated shim (10) to obtain flush condition with washer (11) and inner race of annular ball bearing (9).

- 4 Install new laminated shim (10), washer (11), woodruff key (12), bevel gear (13), flat washer (14), and self-locking bolt (15). Torque self-locking bolt (15) to 120 to 132 in.-lb (13.6 to 14.9 N-m).

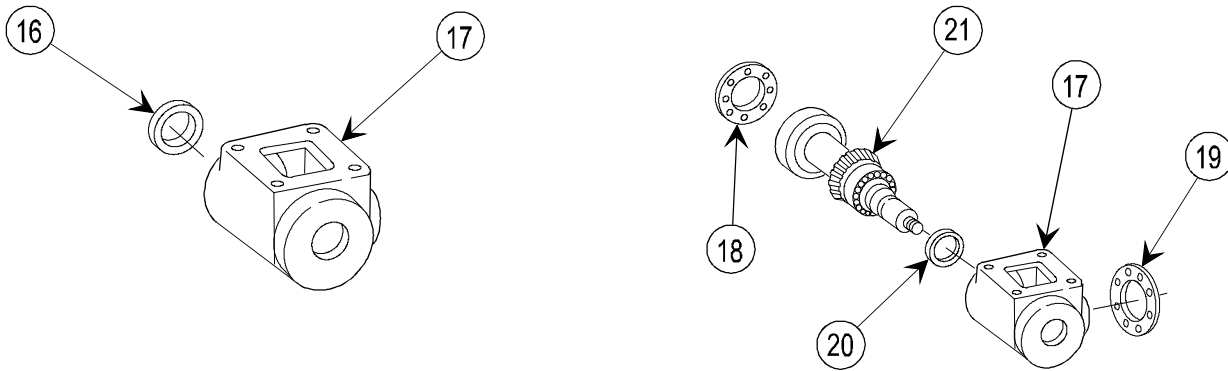

CAUTION

Ensure that seal (16) does not protrude into upper mechanical housing (17) beyond the end of mounting bore.

NOTE

Steps 5 thru 9 are written for upper mechanical housing (17), but also apply to lower mechanical housing.

- 5 Install new seal (16) in upper mechanical housing (17).

NOTE

Thickness of laminated shims must be adjusted to provide a backlash of 0.002 to 0.005 in. (0.005 to 0.012 cm) between mating bevel gears at final assembly. Trial thickness of laminated shims should be based on measurements of backlash and laminated shim thickness taken during disassembly.

Adjust laminated shims (18 and 19) and laminated shim (20) as required to obtain backlash between bevel gears of 0.002 to 0.005 in. (0.005 to 0.013 cm) with shouldered shaft (21) having end play of 0.000 to 0.005 in. (0.00 to 0.013 cm).

- 6 Install new laminated shim (20) in upper mechanical housing (17).

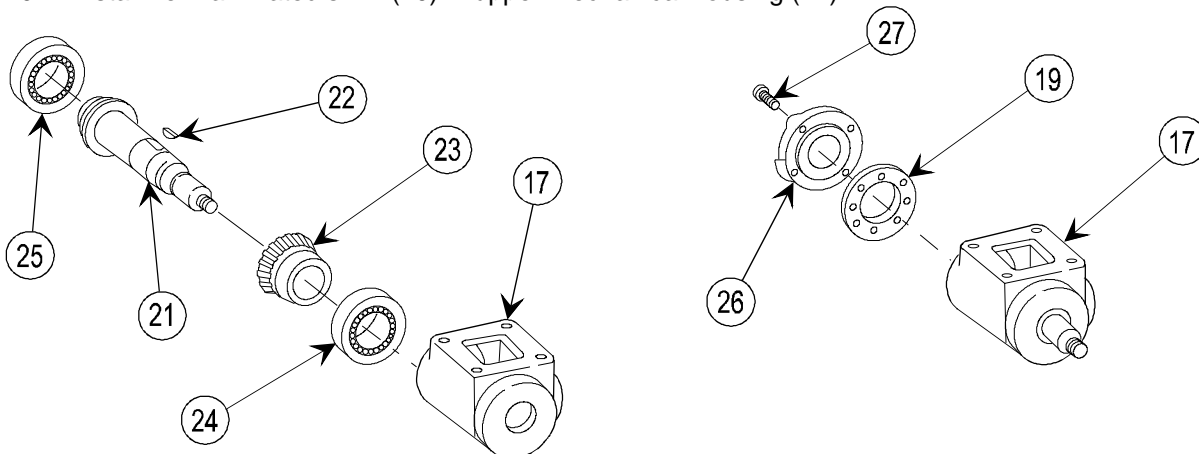

- 7 Install woodruff key (22), bevel gear (23), and annular ball bearings (24 and 25) on shouldered shaft (21).
- 8 Install shouldered shaft (21) with attached parts in upper mechanical housing (17).
- 9 Install new laminated shim (19), access cover (26), and four self-locking screws (27) on upper mechanical housing (17).

2-28. ELEVATING ANGLE DRIVE UNIT—MAINTENANCE INSTRUCTIONS (cont)

REASSEMBLY (cont)

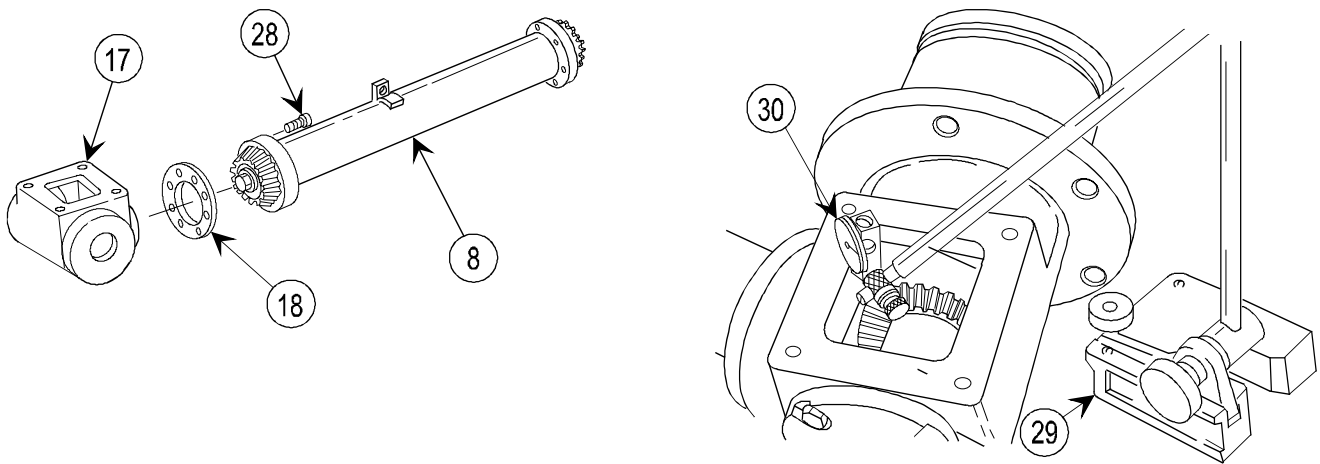

NOTE

Steps 10 thru 25 apply to joining either upper or lower mechanical housing to housing (8).

- 10 Assemble new shim (18), housing (8), and upper mechanical housing (17), making sure scribe marks align.
- 11 Install six self-locking screws (28).
- 12 Measure amount of backlash and end play in upper mechanical housing (17) using surface gage (29) and dial indicator (30).

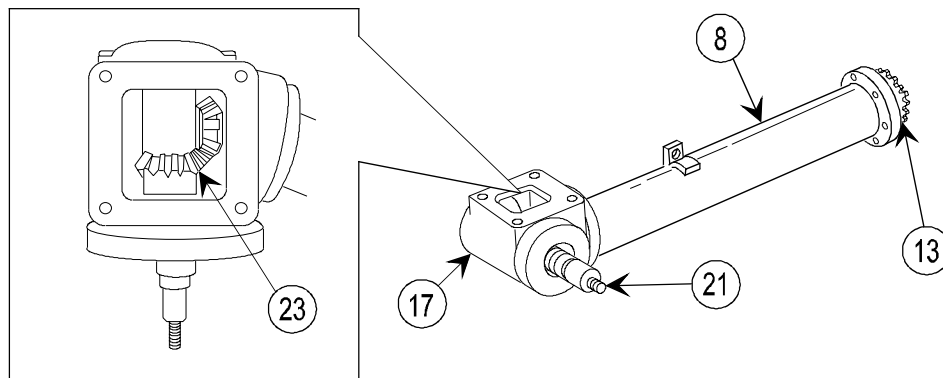

NOTE

Bevel gear (23) must remain stationary.

- 13 Immobilize shouldered shaft (21) and turn bevel gear (13).

CAUTION

Removing layers of shim will lessen backlash. Too little shim will lock gears.

NOTE

Begin with minimum end play. When adjusting shim to compensate backlash, end play will increase. End play must not exceed 0.005 in. (0.013 cm).

If backlash or end play does not fall within tolerance, separate upper mechanical housing (17) from housing (8). Elimination of backlash is accomplished by trial and error. Repeat the following procedure as often as necessary. If backlash remains out of tolerance other components may be faulty. When backlash and end play meet tolerance proceed to step 22.

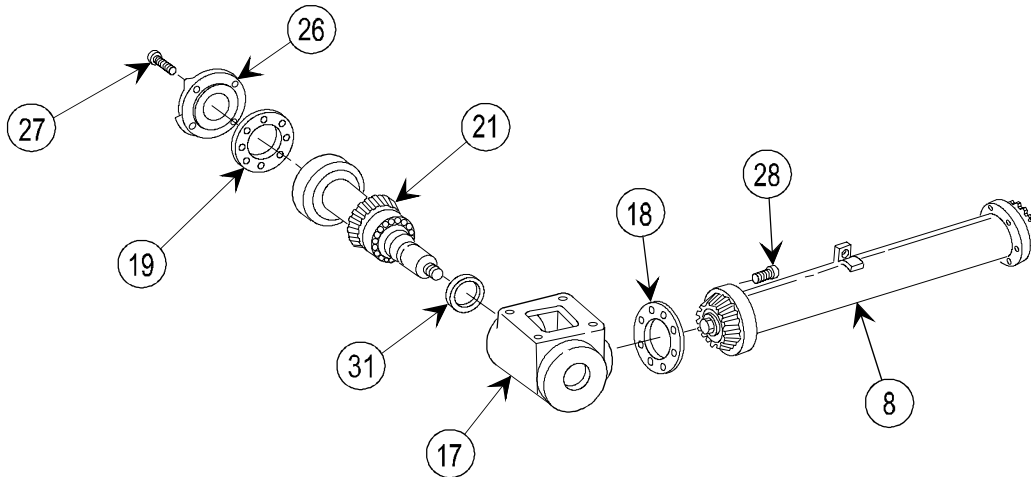

- 14 Remove six self-locking screws (28), shim (18) and upper mechanical housing (17) from housing (8).
- 15 Remove four self-locking screws (27), access cover (26), and shim (19) from upper mechanical housing (17).
- 16 Remove shouldered shaft (21) with attached parts and shim (31). Remove from upper mechanical housing (17).

CAUTION

Removing layers of shim will lessen backlash. Too little shim will lock gears.

- 17 Adjust shim (19) to allow shouldered shaft (21) 0.000- to 0.005-in. (0.000- to 0.013-cm) end play.
- 18 Adjust two shims (18 and 31) by peeling off appropriate layers of laminated shims.
- 19 Install shim (31) and shouldered shaft (21) with attached parts in upper mechanical housing (17).
- 20 Install shim (19), access cover (26), and four self-locking screws (27) on upper mechanical housing (17).
- 21 Install upper mechanical housing (17), shim (18), and six self-locking screws (28) on housing (8).

NOTE

Proceed to step 22 only after backlash and end play have been checked and adjusted to tolerance.

- 22 Remove four self-locking screws (27), access cover (26), and shim (19). Coat both sides of shim with sealing compound; reinstall shim (19), access cover (26), and four self-locking screws (27).
- 23 Remove six self-locking screws (28), upper mechanical housing (17) with attached parts, and shim (18). Coat both sides of shim (18) with sealing compound. Reinstall shim (18), and upper mechanical housing (17) with attached parts and six self-locking screws (28).

2-28. ELEVATING ANGLE DRIVE UNIT—MAINTENANCE INSTRUCTIONS (cont)

REASSEMBLY (cont)

NOTE

Measure backlash and end play after reinstallation of shims to ensure that proper adjustment has been maintained.

- 24 Grease bevel gears (23 and 4) with WTR grease.
- 25 Install gasket (32), access cover (33), and eight self-locking screws (34).

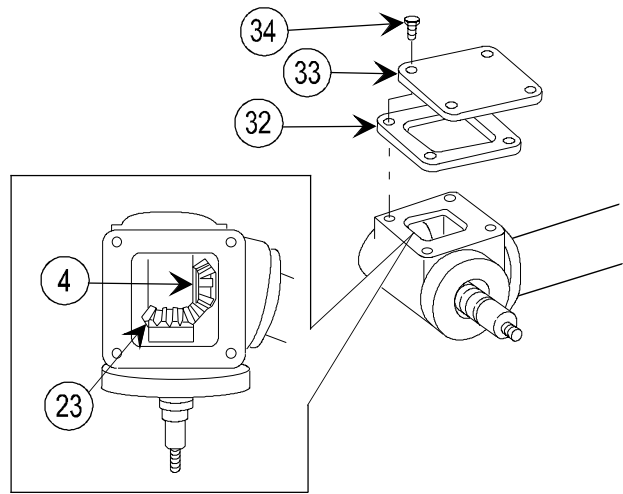

INSTALLATION

- 1 Coat two threaded inserts (1), four threaded inserts (2), and mating holes with primer and install while primer is wet.

NOTE

Shim (3) must be adjusted as necessary to maintain alinement of elevating angle drive unit.

- 2 Install new gasket (4), new shim (3), and elevating angle drive unit (5).
- 3 Install two flat washers (6), six lockwashers (7), and six bolts (8).

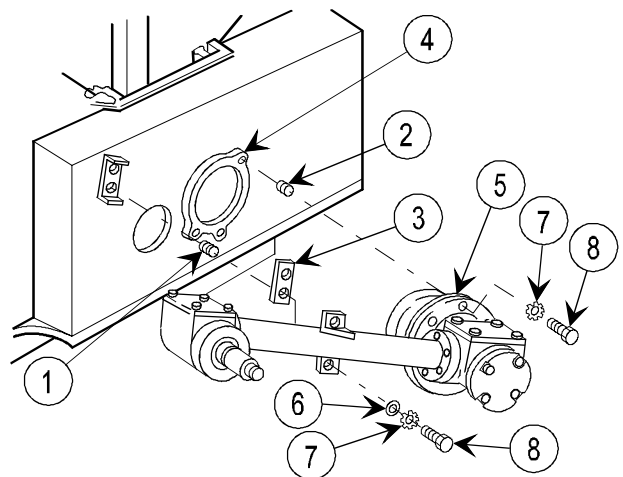

SERVICE

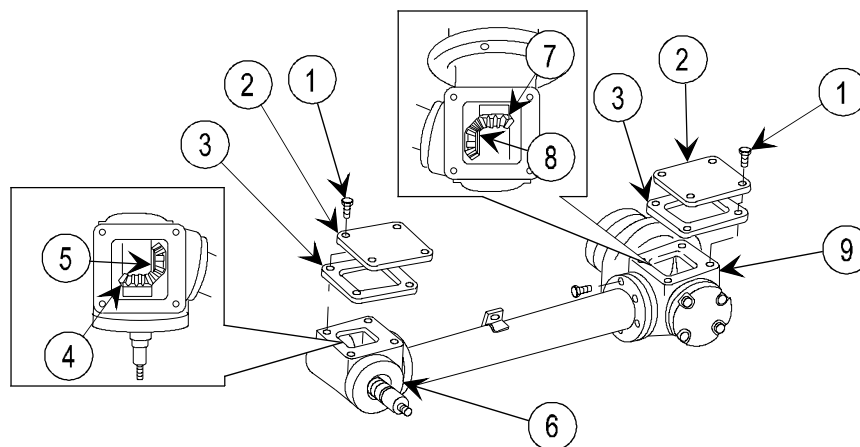

NOTE

Service should be performed at intervals specified in appendix E.

- 1 Remove eight self-locking screws (1), two access covers (2), and two gaskets (3). Grease bevel gears (4 and 5) in upper mechanical housing (6) and bevel gears (7 and 8) in lower mechanical housing (9) using WTR grease.
- 2 Install two gaskets (3), two access covers (2), and eight self-locking screws (1).

2-29. ELEVATING SCREW ASSEMBLY—MAINTENANCE INSTRUCTIONS

THIS TASK COVERS:

- | | | |
|---------------|-----------------|--------------------------------|
| a. Removal | b. Disassembly | c. Inspection/repair |
| d. Reassembly | e. Installation | f. Elevation ball screw timing |

INITIAL SETUP

Tools and Special Tools

- Artillery and turret mechanic's ordnance tool kit (SC 5180-95-CL-A12)
- Artillery field maintenance shop equipment (SC 4933-95-CL-A12)
- Sling
- 3-ton hoist and blocking available

Materials/Parts

- Gasket (2) (12007978)
- Gasket (2) (12007999)
- Lock wire (item 34, appx B)
- Primer (item 20, appx B)
- Seal (2) (12007734)
- Seal (2) (12007749)
- Sling
- 3-ton hoist

Personnel Required: 3

References

- TM 9-1025-211-10
- TM 9-1025-211-34P

Equipment Conditions

- 2-151 Equilibrator cylinder pressure relieved if cannon tube or recoil mechanism is removed
- Wheels down (TM 9-1025-211-10)
- Cannon tube lowered from 750-mil elevation to 700 mils for removal of backlash (TM 9-1025-211-10)

General Safety Instructions

WARNING

All lifting devices must be checked in accordance with local Standing Operating Procedure (SOP) to make sure they are in good working condition before starting the lifting operation.

2-29. ELEVATING SCREW ASSEMBLY—MAINTENANCE INSTRUCTIONS (cont)

REMOVAL

CAUTION

Care should be taken not to damage inserts when removing six bolts (1).

NOTE

There are two elevating screw assemblies and attaching parts; procedures are written for one.

- 1 Loosen six bolts (1), then pull out on elevating angle drive unit (2) to provide clearance for removal of six bolts. Remove six bolts (1), six lockwashers (3), and two flat washers (4) from top carriage assembly (5).
- 2 Remove elevating angle drive unit (2) and shim (6) from top carriage assembly (5).
- 3 Remove gasket (7).
- 4 Disengage straight shaft (8) by pulling out.
- 5 Remove lock wire (9).
- 6 Remove nut (10) from elevating screw assembly (11).

NOTE

There are two rotating eye brackets for each elevating screw assembly. Steps 7 thru 11, 13, and 14 apply to both.

- 7 Remove lock wire (12).
- 8 Remove two capscrews (13) and two washers (14) from rotating eye bracket (15) on side of cradle assembly (16).

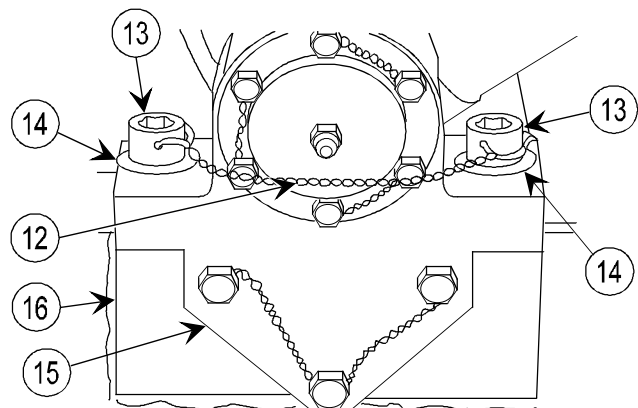
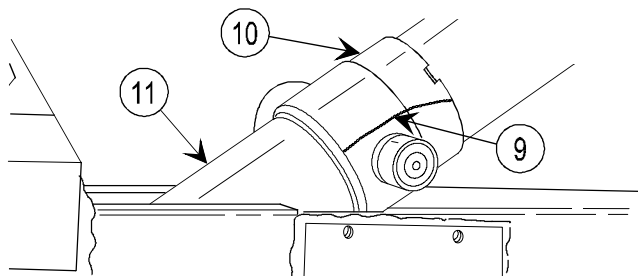
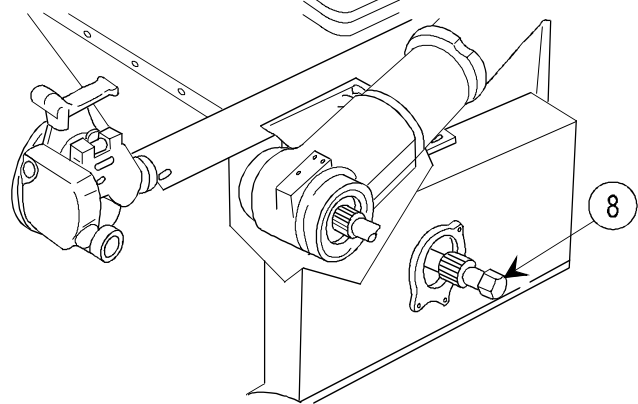
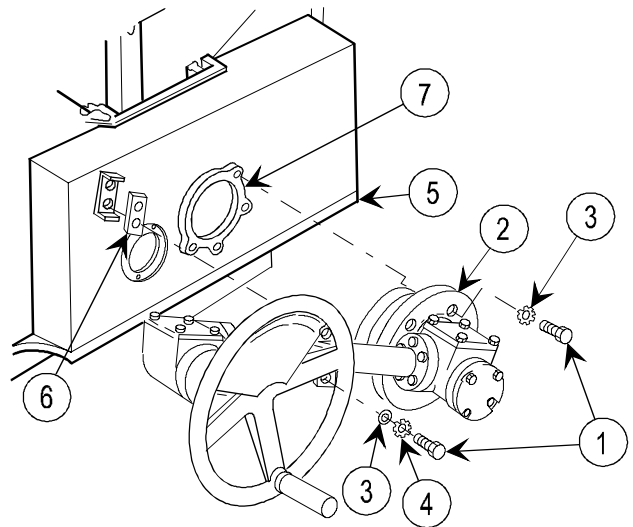

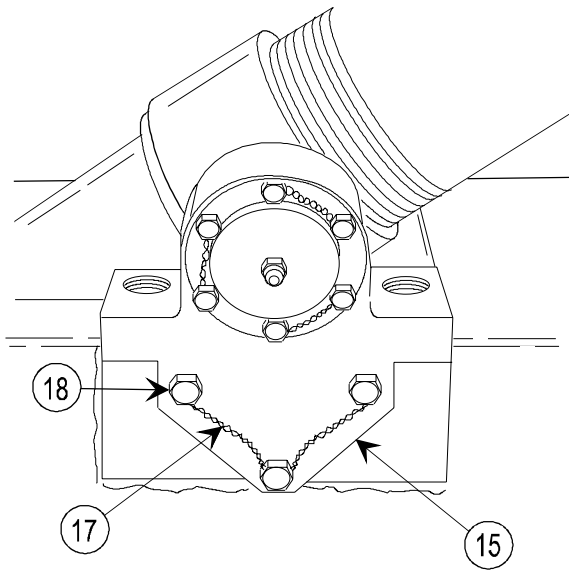

- 9 Remove lock wire (17).
- 10 Remove three bolts (18) from rotating eye bracket (15).

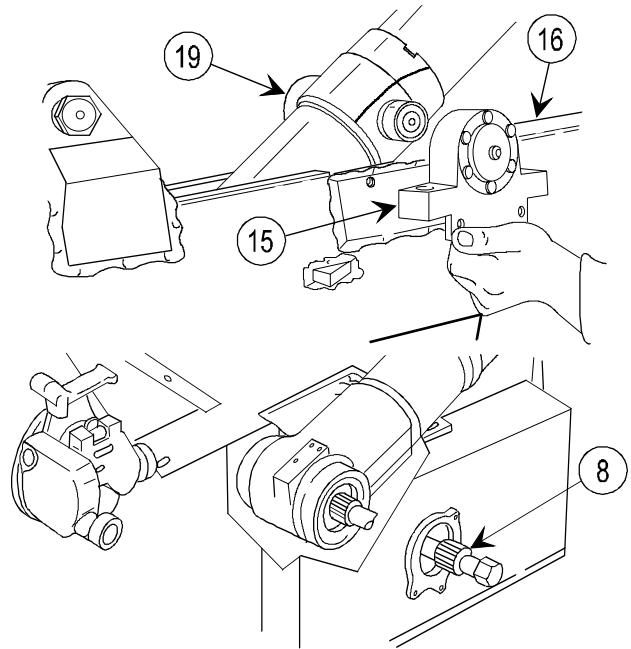

- 11 Insert straight shaft (8) middle spline into spline of ball screw; then turn counterclockwise (elevate) until rotating eye bracket (15) is free of cradle assembly (16).
- 12 Remove two rotating eye brackets (15) from yoke (19).

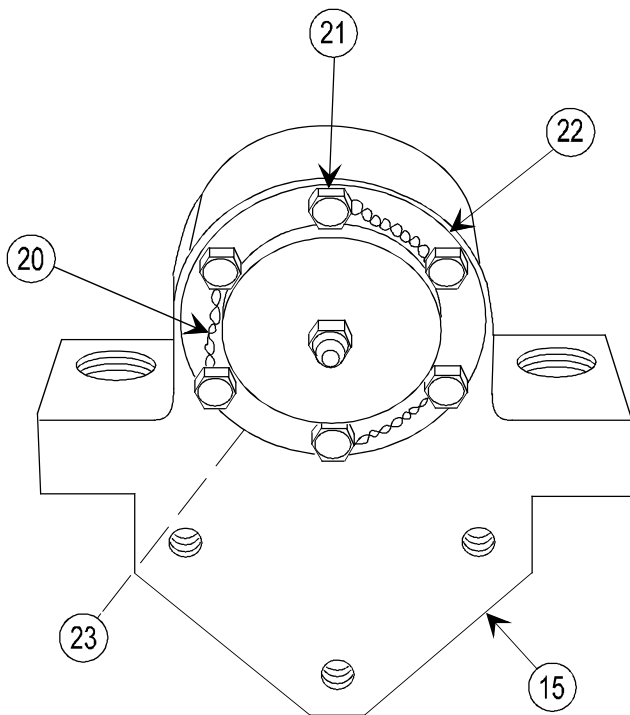

- 13 Remove lock wire (20), six bolts (21), access cover (22), and gasket (23) from rotating eye bracket (15).

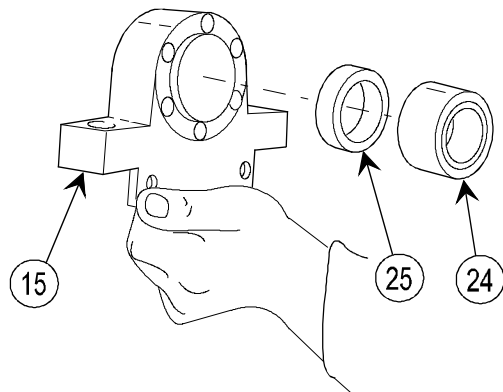

- 14 Remove bearing (24) and seal (25) from rotating eye bracket (15).

2-29. ELEVATING SCREW ASSEMBLY—MAINTENANCE INSTRUCTIONS (cont)

REMOVAL (cont)

- 15 Remove yoke (26) with two keys (27) from elevating screw assembly (11).

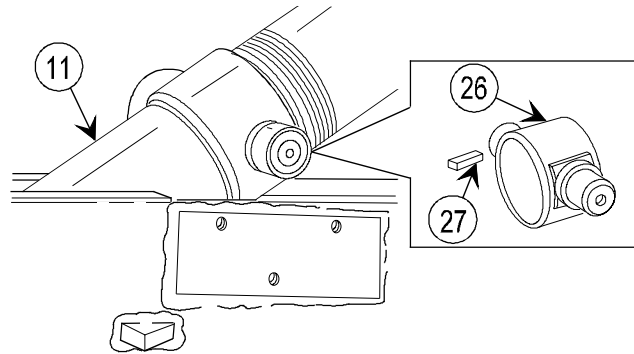

CAUTION

Removing threaded inserts may cause damage. Do not remove them unless necessary for replacement of authorized parts.

- 16 Remove two threaded inserts (28) and three threaded inserts (29).

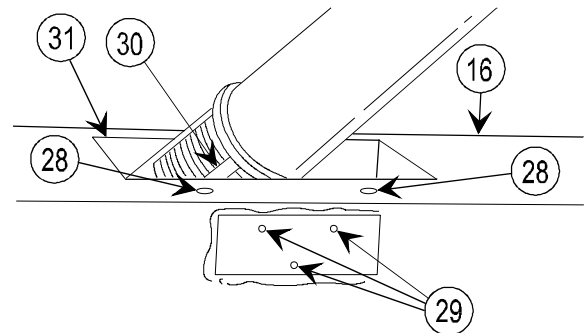

CAUTION

Flats (30) should be lined up with slot (31) in cradle assembly (16) to prevent damage to threads.

- 17 Turn straight shaft (8) clockwise to depress elevating screw assembly (11).

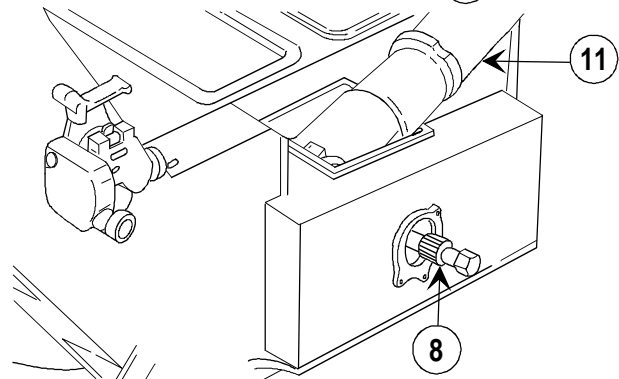

- 18 Remove four bolts (32) and four lockwashers (33).

- 19 Remove two retaining straps (34).

NOTE

Caps (35) are not interchangeable and may not be replaced by direct support. Mark caps prior to removal to assure exact reassembly.

- 20 Remove two caps (35).

- 21 Remove straight shaft (8).

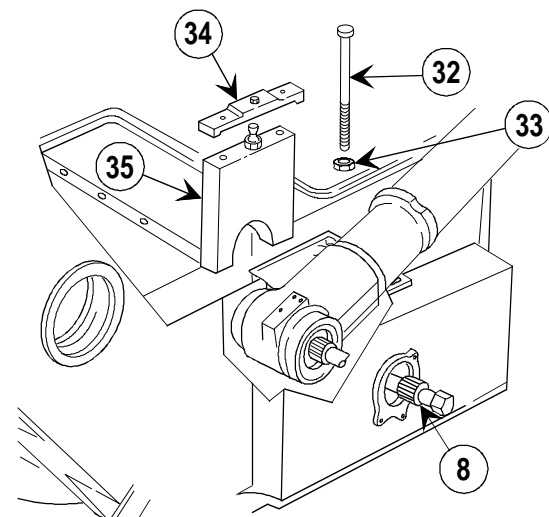

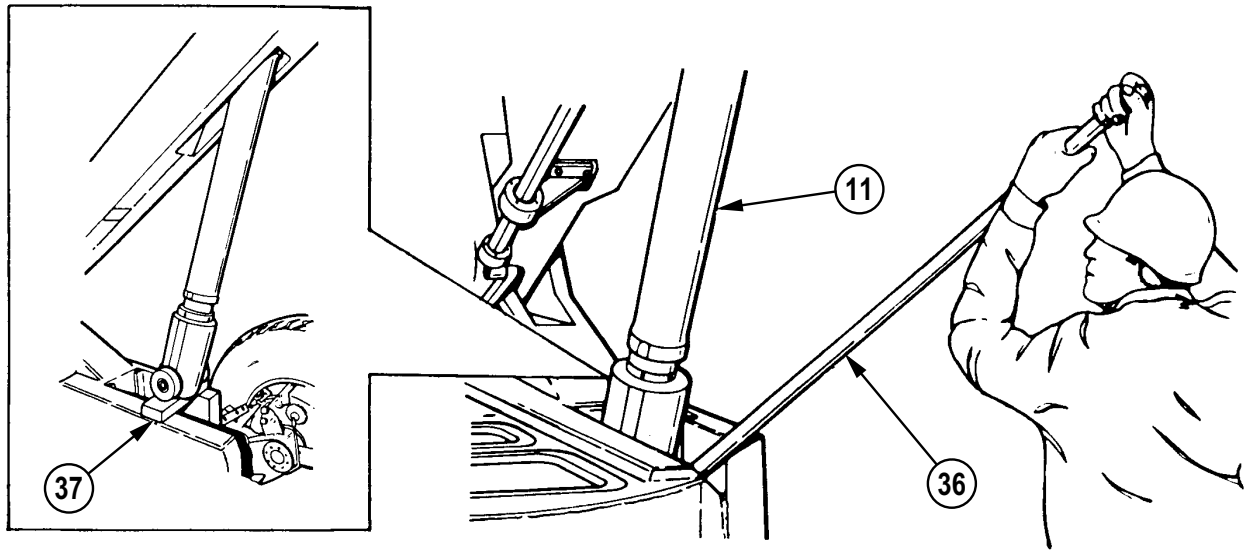

- 22 Place handspike (36) under lower end of elevating screw assembly (11), and raise high enough to place blocks (37) underneath.

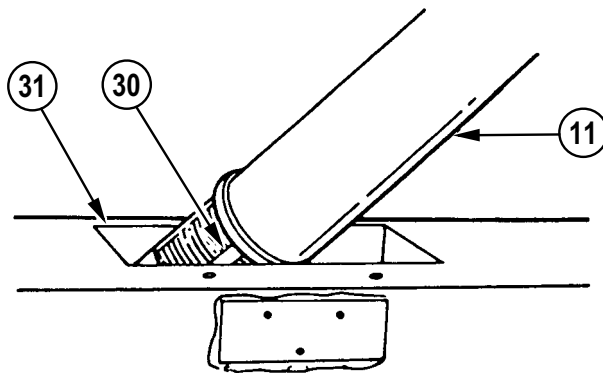

- 23 Slide straight shaft (8) through lower end of elevating screw assembly (11). Two personnel will lift elevating screw assembly using straight shaft as a handhold.
- 24 Raise elevating screw assembly (11) until lower end clears top carriage assembly (5). Third person will assist in supporting the top end of the elevating screw assembly.
- 25 Aline elevating screw assembly flats (30) until they are parallel with cradle slot (31); then lower elevating screw assembly (11) through cradle slot.
- 26 Place elevating screw assembly (11) on suitable work surface. Remove straight shaft (8).

2-29. ELEVATING SCREW ASSEMBLY—MAINTENANCE INSTRUCTIONS (cont)

DISASSEMBLY

Remove two retainers (1) and two seals (2) from elevating screw assembly (3).

INSPECTION/REPAIR

- 1 Check for any broken, damaged, or missing parts.
- 2 Repair is by replacement of authorized parts (TM 9-1025-211-34P).

REASSEMBLY

Install two retainers (1) and two seals (2) on lower end of elevating screw assembly (3).

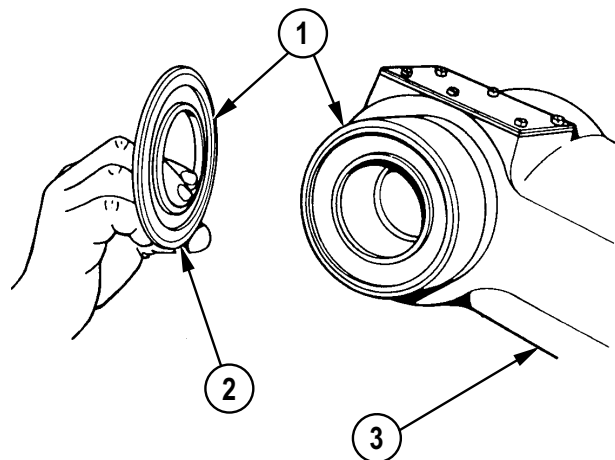

INSTALLATION

NOTE

Procedures are written for one elevating screw assembly, but apply to both.

Replace elevating screw assemblies (TM 9-1025-211-34P) if they cannot be extended or depressed or if external threads for yoke are stripped.

- 1 Attach sling (1) to 3-ton hoist (2) and elevating screw assembly (3).

NOTE

Ensure that lower cover plate (4) is facing breech assembly during installation of elevating screw assembly as shown.

- 2 Raise 3-ton hoist (2) high enough to put top of elevating screw assembly (3) through cradle slot (5).
- 3 Ensure flats (6) are parallel to cradle slot (5).
- 4 Using 3-ton hoist (2), carefully lower elevating screw assembly (3) into top carriage assembly (7), ensuring that retainers and seals are not damaged.
- 5 Remove sling (1) and 3-ton hoist (2) from elevating screw assembly (3).

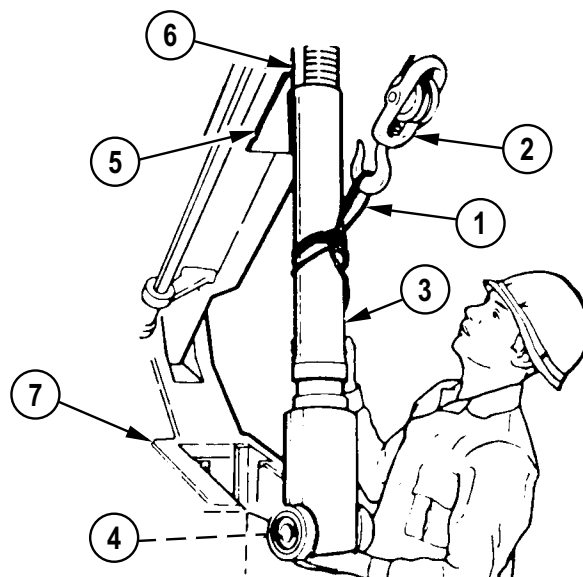

- 6 Install straight shaft (8) into first spline of elevating screw assembly (3).

NOTE

Make sure caps (9) are installed as originally assembled.

- 7 Install two caps (9).

- 8 Install two retaining straps (10).

- 9 Install four lockwashers (11) and four bolts (12); torque bolts to 230 ± 30 ft-lb (310 ± 40.50 N-m).

NOTE

Straight shaft (8) should be installed just far enough to engage screw assembly (3).

- 10 Turn straight shaft (8) until high enough for yoke (13) to be installed.

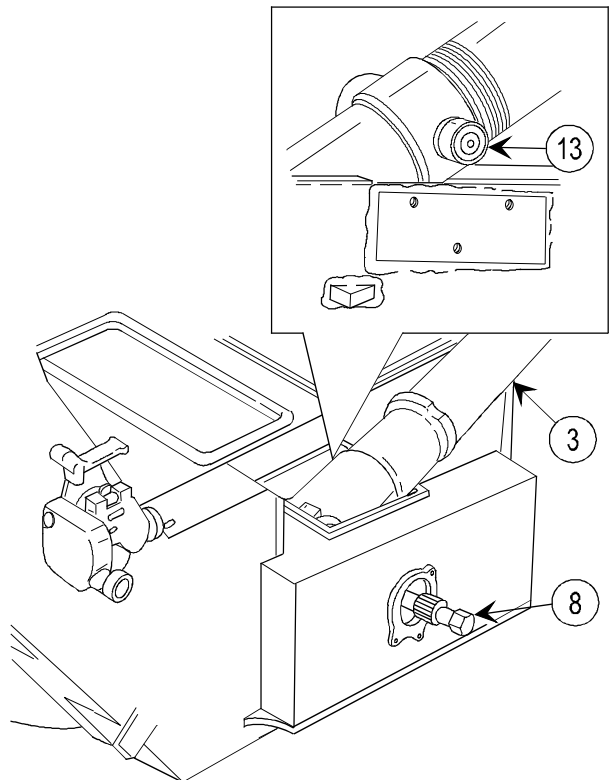
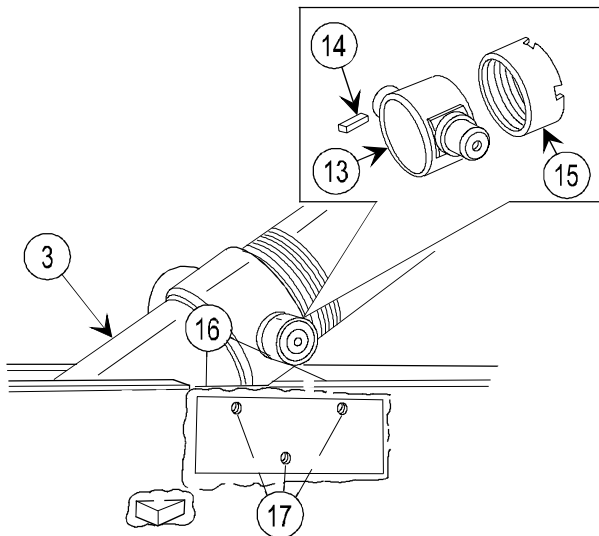
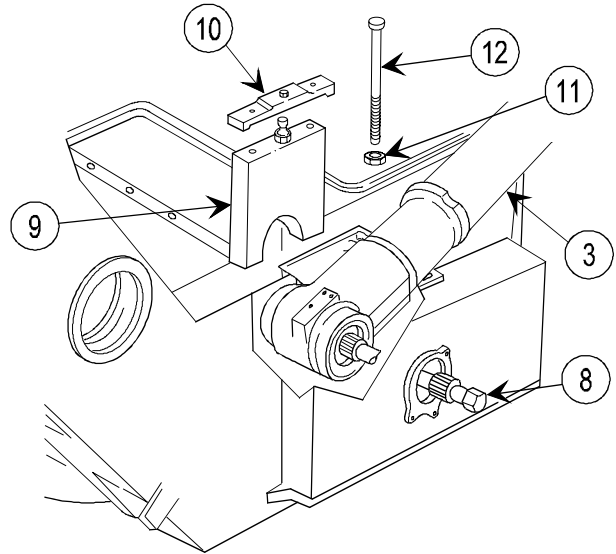

- 11 Install two keys (14) in yoke (13).

- 12 Install yoke (13) with keys (14) on elevating screw assembly (3).

- 13 Install nut (15) and tighten.

- 14 Install lock wire.

- 15 Coat two threaded inserts (16) and three threaded inserts (17) and mating holes with primer and install while primer is wet.

2-29. ELEVATING SCREW ASSEMBLY—MAINTENANCE INSTRUCTIONS (cont)

INSTALLATION (cont)

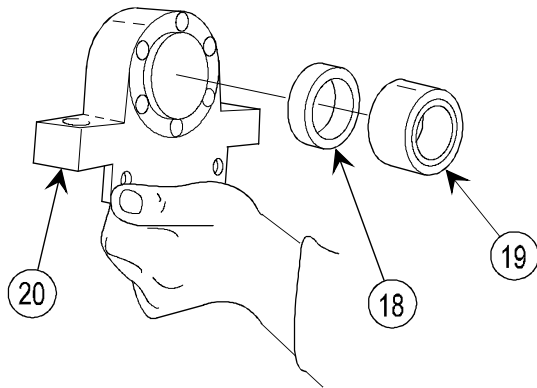

16 Install new seal (18) and bearing (19) in rotating eye bracket (20).

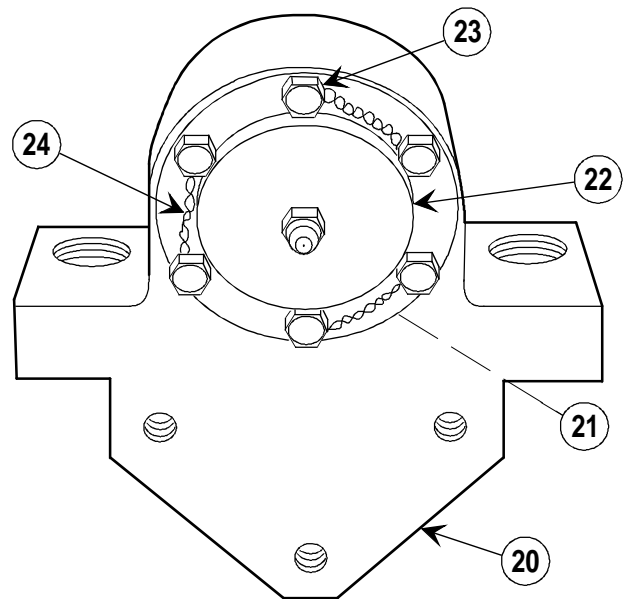

17 Install new gasket (21), access cover (22), and six bolts (23) on rotating eye bracket (20).

18 Install lock wire (24).

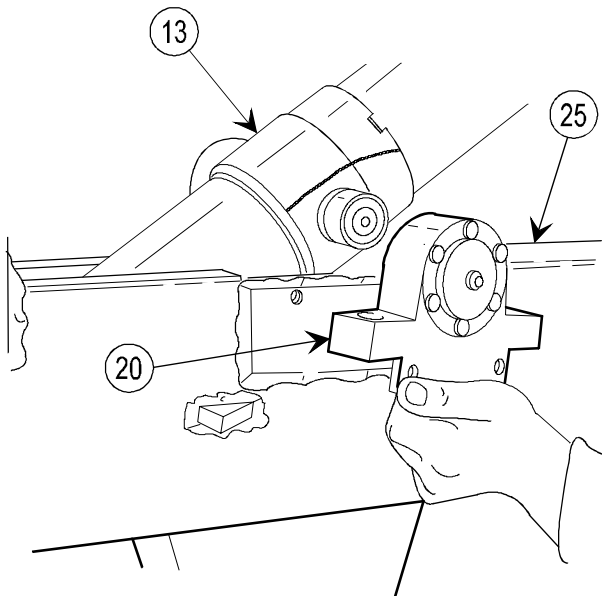

19 Install two rotating eye brackets (20) on yoke (13).

20 Lower elevating screw assembly (3) by turning straight shaft (8) until rotating eye bracket (20) is flush against cradle assembly (25).

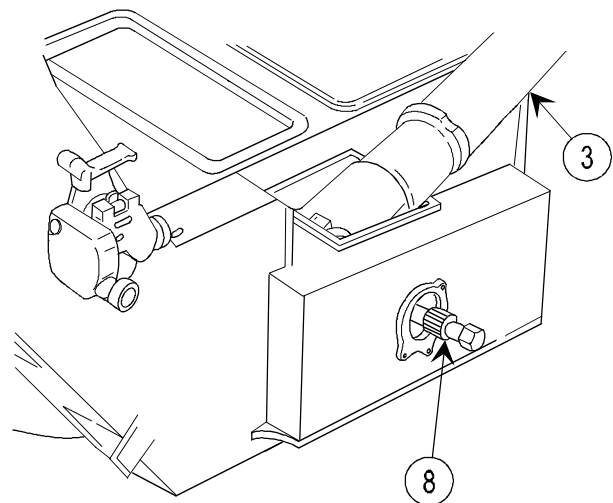

- 21 Install three bolts (26) snugly in rotating eye bracket (20), then loosen.
- 22 Install two washers (27) and two capscrews (28) in rotating eye bracket (20) on side of cradle assembly (25) and torque 90 to 120 ft-lb (121.50 to 162.00 N-m).
- 23 Install lock wire (29).
- 24 Tighten three bolts (26), torque to 23 +2 ft-lb (31.05 +2.7 N-m) and install lock wire (30).

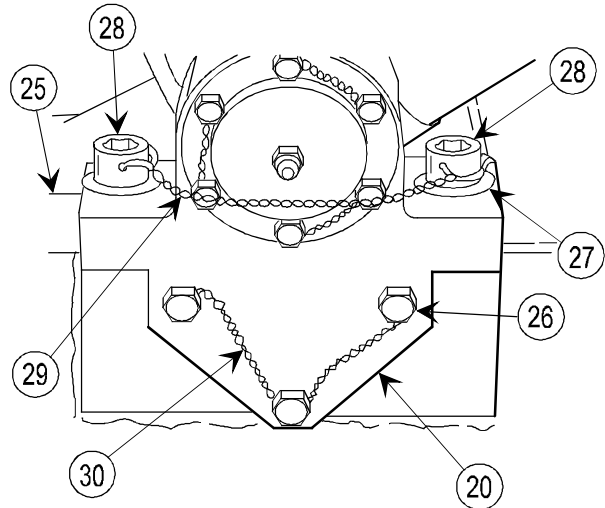

- 25 Insert straight shaft (8) into friction clutch (31), and rotate clockwise to engage spline.

NOTE

Shim (32) must be adjusted as necessary to obtain proper seating of elevating angle drive unit (33) on top carriage assembly (7).

- 26 Install new gasket (34), shim (32), and elevating angle drive unit (33) on top carriage assembly (7). Rotate elevating handwheel (35) for proper engagement into splined shaft.

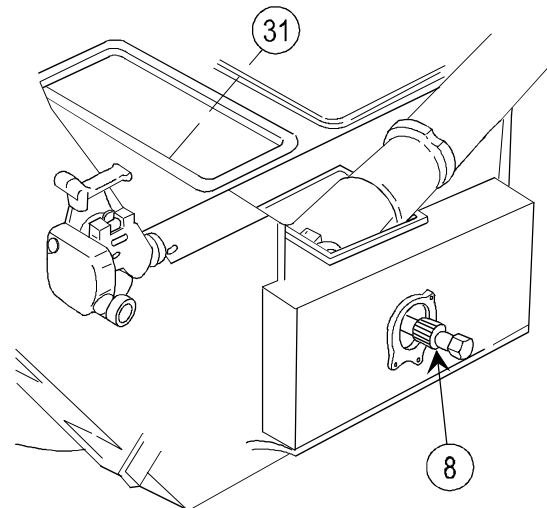

- 27 Install two flat washers (36), six lockwashers (37), and six bolts (38) in top carriage assembly (7).

NOTE

Elevate/depress cannon tube to ensure there is no binding or chatter in elevating mechanism.

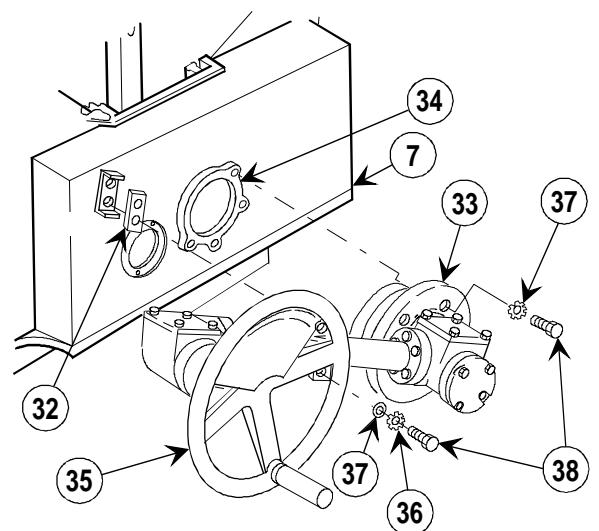

2-29. ELEVATING SCREW ASSEMBLY—MAINTENANCE INSTRUCTIONS (cont)

ELEVATION BALL SCREW TIMING

NOTE

Prior to timing ballscrews, ensure that equilibrators are charged to 1600 psi (11,032 kPa) and both ballscrew access covers are up. Cannon and recoil mechanism do not have to be removed for this operation. If removed, equilibrator pressure should be reduced to 250 psi (1724 kPa); this will allow the cradle assembly to be elevated with no assistance.

- 1 Attach sling to the two clevis on cradle assembly and attach to 3-ton hoist to support the weapon in elevated position (700 mils).
- 2 Remove elevating angle drive unit (p 2-182) for the side elevating ball screw will be detached.
- 3 Remove screws and washers from rotating eye brackets.
- 4 Remove both rotating eye brackets.
- 5 Remove straight shaft from elevating screw assembly.
- 6 Elevate the cradle assembly approximately 50 mils, then depress the cradle assembly 50 mils to eliminate backlash in the elevation ball screw.
- 7 Install rotating eye brackets on the elevation ball screw.
- 8 Engage the straight shaft in the elevating ball screw only, and lower screw assembly until the rotating eye brackets are in full contact with the cradle assembly.
- 9 Install washers and bolts and torque per installation instructions (p 2-199).
- 10 Install straight shaft through elevation ball screw assembly and engage the friction clutch, taking care not to rotate the ball screw any more than necessary, to aline shaft salines.
- 11 Install elevation angle drive.
- 12 Disconnect the 3-ton hoist and sling.
- 13 Elevate and depress howitzer to ensure timing of the elevation ball screws has been accomplished; repeat steps as required if timing is not obtained.

NOTE

Support detached ball screw during elevation and depression of cradle assembly.

2-30. BRACKET ASSEMBLY—MAINTENANCE INSTRUCTIONS

THIS TASK COVERS:

- | | | |
|----------------------|-----------------|----------------|
| a. Inspection/repair | b. Removal | c. Disassembly |
| d. Reassembly | e. Installation | |

INITIAL SETUP

Tools and Special Tools

Artillery and turret mechanic's ordnance tool kit (SC 5180-95-CL-A12)

Materials/Parts

Cotter pin (4) (MS24665-283)

Gasket (2) (12008085)

Primer (item 20, appx B)

Seal (2) (12008037)

References

TM 9-1025-211-34P

INSPECTION/REPAIR

- 1 Inspect bracket assembly (1) for cracks, nicks, and burrs. Remove and replace if cracked or broken.
- 2 Repair is by replacement of authorized parts (TM 9-1025-211-34P) as required.

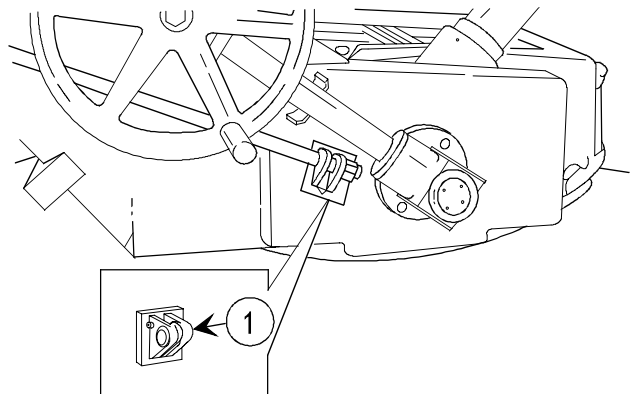

REMOVAL

NOTE

There are two bracket assemblies; procedures are given for one.

Some components addressed in this procedure are not part of the bracket assembly. Elevating angle drive unit shown removed for clarity.

- 1 Remove cotter pin (1).
- 2 Remove washer (2).
- 3 Slip up, rotate, and remove manual control lever (3) and torsion spring (4).

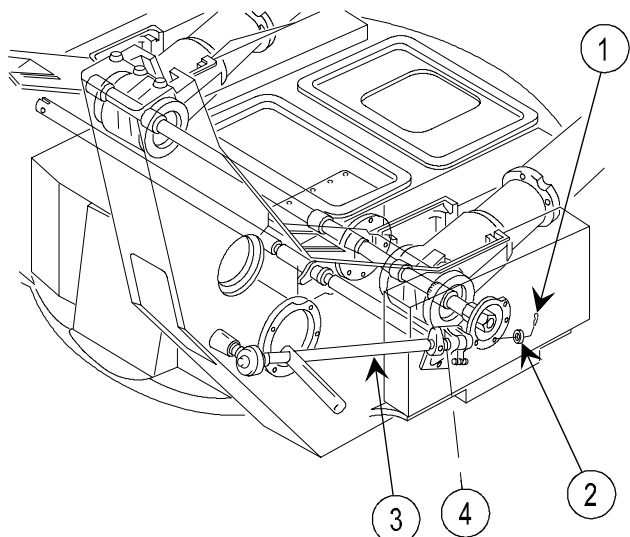

2-30. BRACKET ASSEMBLY—MAINTENANCE INSTRUCTIONS (cont)

DISASSEMBLY

- 1 Remove cotter pin (1), washer (2), pin (3), and control pivot arm (4) from rigid connecting link (5).
- 2 Remove pin (6) from rigid connecting link (5) and shaft (7).
- 3 Remove rigid connecting link (5) from shaft (7).
- 4 Remove two bolts (8) and two lockwashers (9).
- 5 Remove bracket assembly (10) and gasket (11).

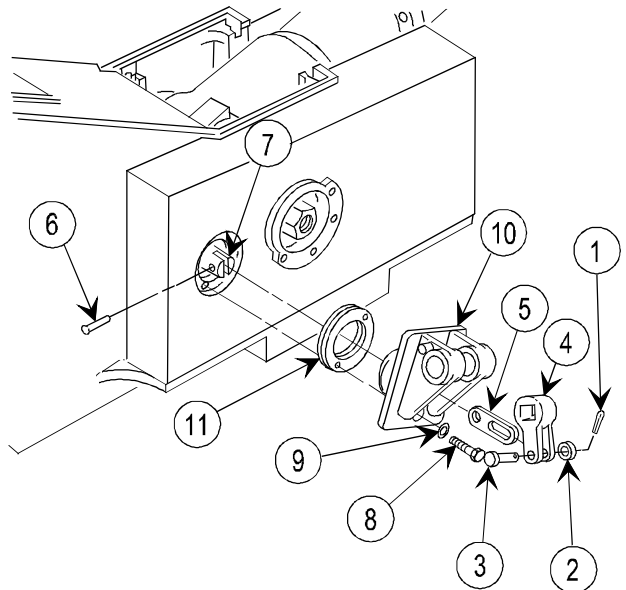

- 6 Drive seal (12) and sleeve bearing (13) out of bracket assembly (10).

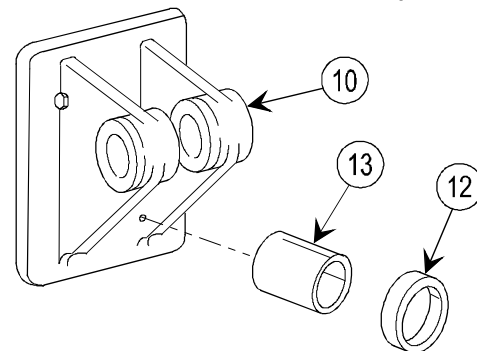

- 7 Remove two setscrews (14) from stop (15)
- 8 Remove stop (15) from manual control lever (3).

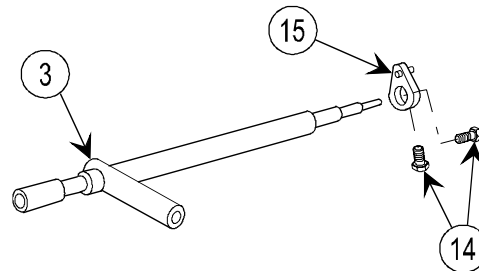

- 9 Remove rod end plain bearing (16) from top carriage assembly (17).

CAUTION

Removing threaded insert may cause damage. Do not remove unless necessary for replacement of authorized parts.

- 10 Remove threaded insert (18).

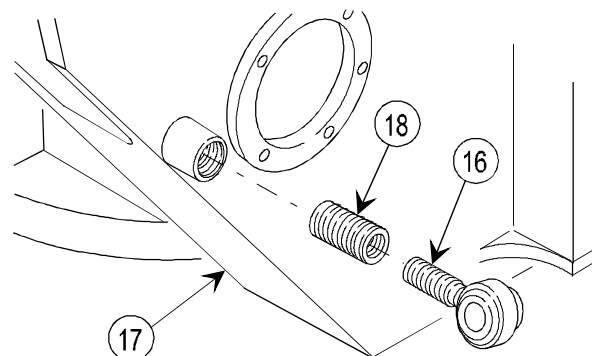

REASSEMBLY

- 1 Coat threaded insert (1) and mating hole with primer and install while primer is wet.
- 2 Install rod end plain bearing (2) in top carriage assembly (3).
- 3 Install stop (4) on manual control lever (5).
- 4 Install two setscrews (6) on stop (4).
- 5 Install sleeve bearing (7) and new seal (8).
- 6 Install new gasket (9) and bracket assembly (10).
- 7 Install two lockwashers (11) and two bolts (12).
- 8 Attach rigid connecting link (13) to shaft (14).
- 9 Install pin (15).
- 10 Install control pivot arm (16), pin (17), washer (18), and new cotter pin (19) on rigid connecting link (13).

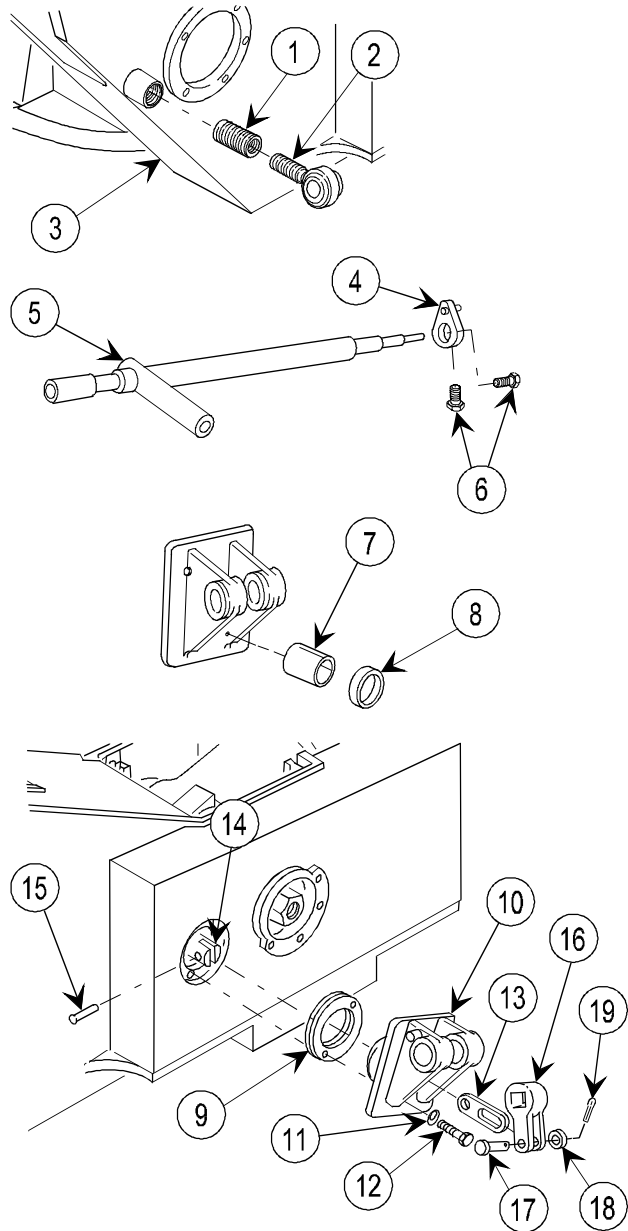

INSTALLATION

- 1 Install manual control lever (1) and torsion spring (2) into bearing (3), bracket assembly (4) and control pivot arm (5).
- 2 Install washer (6).
- 3 Install new cotter pin (7).

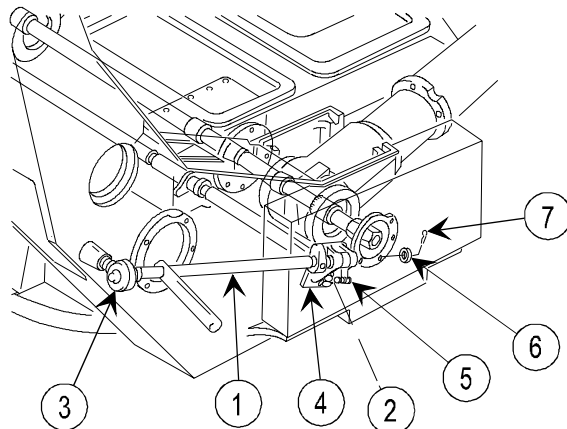

2-31. FRICTION CLUTCH—MAINTENANCE INSTRUCTIONS

THIS TASK COVERS:

- | | | |
|---------------|-----------------|----------------------|
| a. Removal | b. Disassembly | c. Inspection/repair |
| d. Reassembly | e. Installation | f. Service |

INITIAL SETUP

Tools and Special Tools

- Artillery field maintenance shop equipment (SC 4933-95-CL-A12)
- Artillery and turret mechanic's ordnance tool kit (SC 5180-95-CL-A12)
- M198 repairman field artillery tool kit (5911278)
- Sling
- 3-ton hoist

Materials/Parts

- | | |
|-----------------------------------|------------------------------------|
| Abrasive cloth (item 8, appx B) | Laminated shim (2) (12008996) |
| Cleaning solvent (item 7, appx B) | Lock wire (item 34, appx B) |
| Cotter pin (2) (MS24665-283) | Plastic molding (3) (12007744) |
| Gasket (12008094) | Prefomed packing (2) (MS28775-116) |
| Gasket (12008095) | Primer (item 20, appx B) |
| Gasket (12008273) | Sealing compound (item 26, appx B) |
| GMD grease (item 13, appx B) | WTR grease (item 11, appx B) |

References

- TM 9-1025-211-10
- TM 9-1025-211-34P

Equipment Conditions

- Cannon tube elevated approximately 600 mils (TM 9-1025-211-10)

General Safety Instructions

WARNING

All lifting devices must be checked in accordance with local Standing Operating Procedure (SOP) to make sure they are in good working condition before starting the lifting operation.

REMOVAL

- 1 Remove 14 capscrews (1) and 14 lockwashers (2).

NOTE

The second gasket (3) and standoff (4) are on modified howitzers only.

- 2 Remove rear access cover (5), two gaskets (3), and standoff (4).

CAUTION

Care should be taken not to damage inserts when removing 12 bolts.

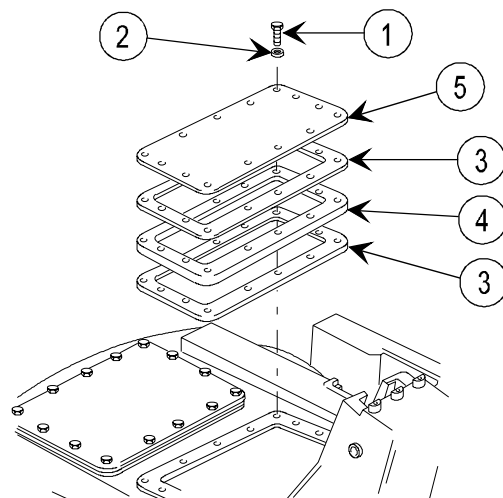

NOTE

There are two elevating angle drive units; only one is illustrated.

- 3 Loosen 12 bolts (6), then pull out on elevating angle drive unit (7) to provide clearance for removal of 12 bolts. Remove 12 bolts (6), 12 lockwashers (8), and four flat washers (9).
- 4 Remove two elevating angle drive units (7) and two laminated shims (10).

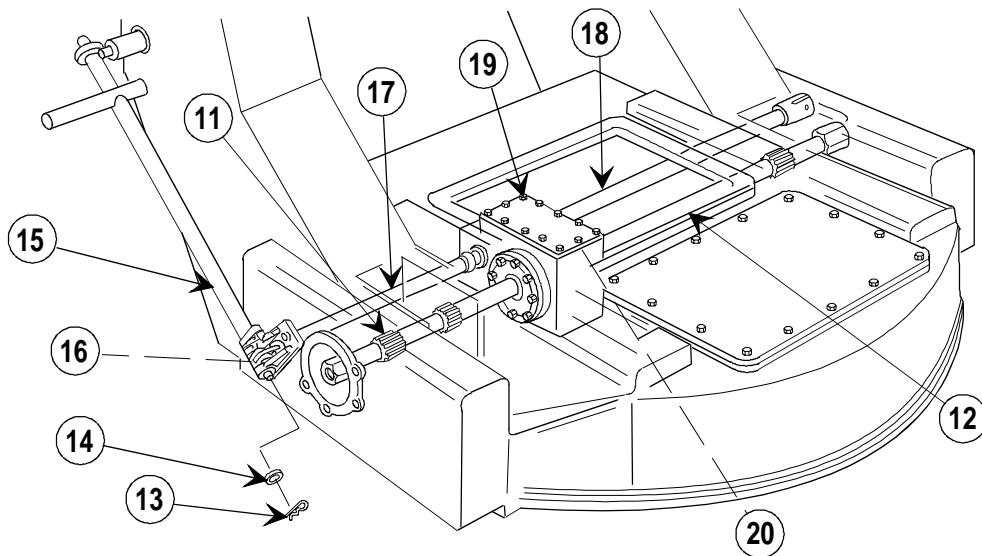
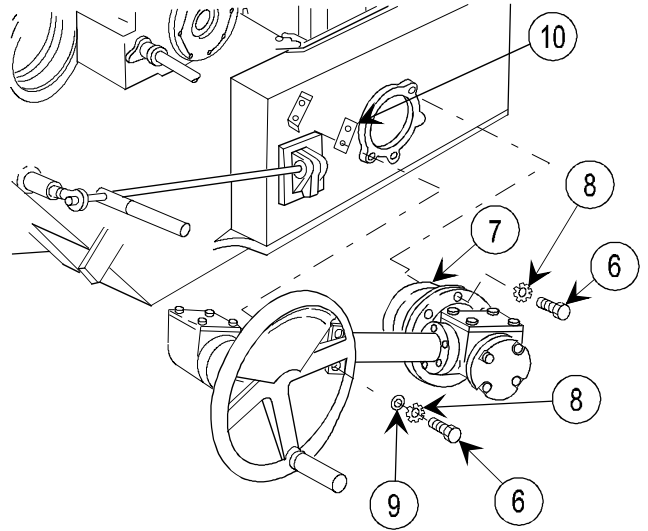

WARNING

If cannon tube and recoil mechanism are removed, equilibrators cylinders must be lowered to 250 psi (1724 kPa) and cradle assembly supported in elevated position.

NOTE

Measure and record distance that right shaft (17) and left shaft (18) protrude from top carriage. Shafts must be assembled to recorded dimensions.

- 5 Remove right straight shaft (11).
- 6 Remove left straight shaft (12).
- 7 Remove two cotter pins (13).
- 8 Remove two washers (14).
- 9 Slip up, rotate, and remove two manual control levers (15) and two torsion springs (16).
- 10 Unscrew and remove right shaft (17) and attached parts.
- 11 Unscrew and remove left shaft (18) and attached parts.
- 12 Remove 12 screws (19) and 12 lockwashers (20).

2-31. FRICTION CLUTCH—MAINTENANCE INSTRUCTIONS (cont)

REMOVAL (cont)

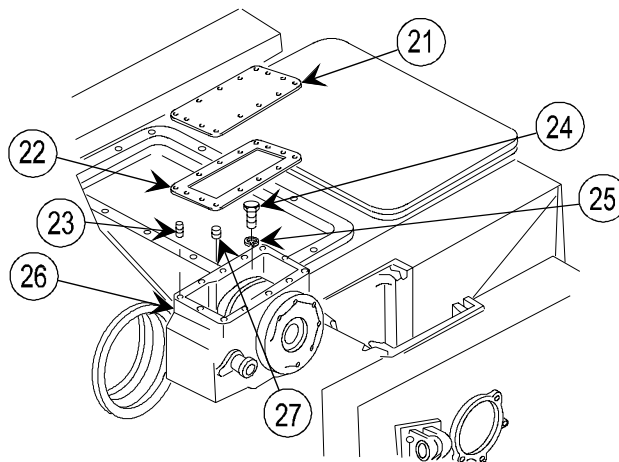

- 13 Remove access cover (21) and gasket (22).

CAUTION

Removing threaded inserts may cause damage. Do not remove them unless necessary for replacement of authorized parts.

- 14 Remove 12 threaded inserts (23).
15 Remove four bolts (24) and four lockwashers (25).
16 Remove friction clutch (26).
17 Remove four threaded inserts (27).

DISASSEMBLY

NOTE

Disassembly of friction clutch should only be performed to the extent required for repair or service.

- 1 Drive out spring pin (1) through shifter fork (2) and rigid connecting link (3).
2 Remove rigid connecting link (3).
3 Remove two spring pins (4).
4 Remove two bushings (5 and 6) from housing (7), using spanner wrench.
5 Remove spring (8).
6 Remove two preformed packings (9) from inside two bushings (5 and 6).

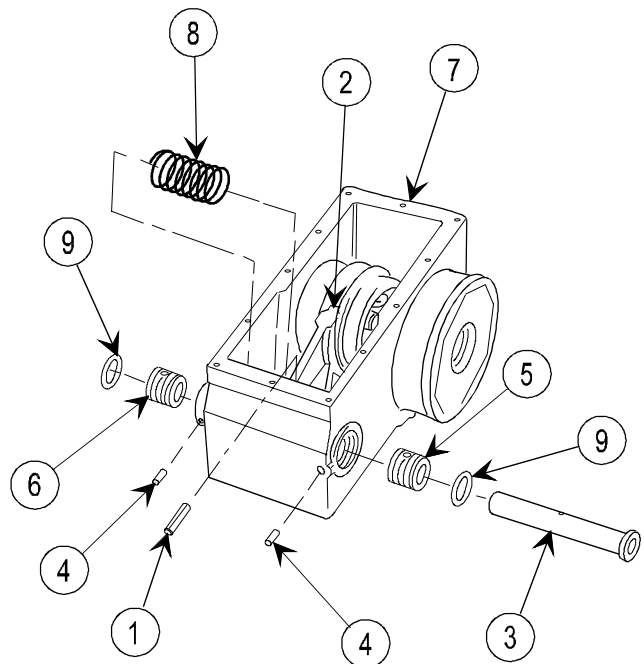

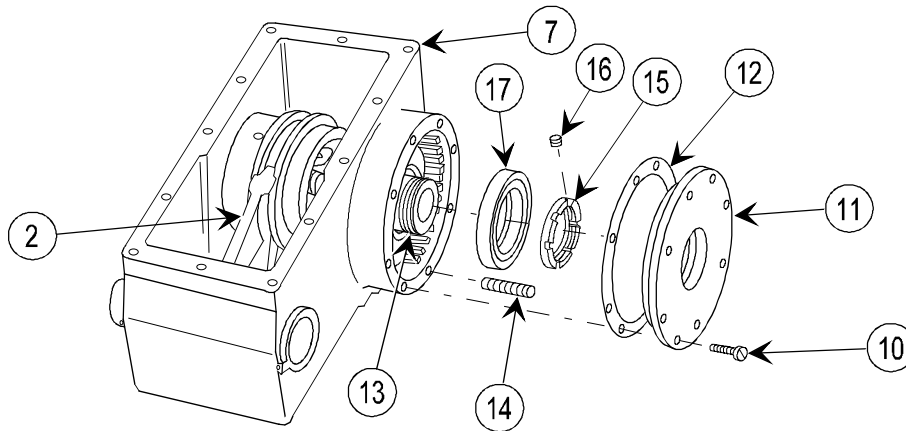

- 7 Remove shifter fork (2). Clean with cleaning solvent.
- 8 Remove lock wire and eight screws (10).
- 9 Remove fitting end (11) and gasket (12) from rigid shaft coupling (13) and housing (7). Check gasket for tears or deterioration; replace if necessary.

CAUTION

Removing threaded inserts may cause damage. Do not remove them unless necessary for replacement of authorized parts.

- 10 Remove eight inserts (14).
- 11 Using spanner wrench, remove nut (15) from rigid shaft coupling (13).
- 12 Remove plastic molding (16) from inside nut (15).
- 13 Remove ball bearing (17). Check for evidence of failure or excessive wear; replace if necessary.

- 14 Remove nut (18).
- 15 Remove plastic molding (19) from inside nut (18).
- 16 Remove friction clutch (20) with attached parts.
- 17 Remove externally threaded ring (21).
- 18 Remove plastic molding (22) from inside externally threaded ring (21).
- 19 Remove ball bearing (23). Check for evidence of failure or excessive wear; replace if necessary.

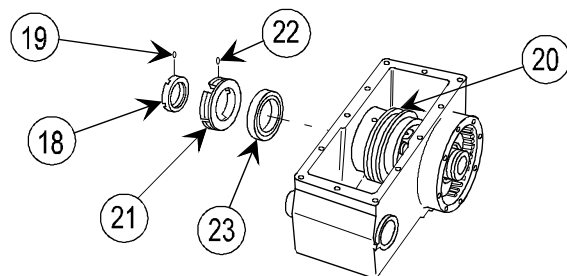

2-31. FRICTION CLUTCH—MAINTENANCE INSTRUCTIONS (cont)

DISASSEMBLY (cont)

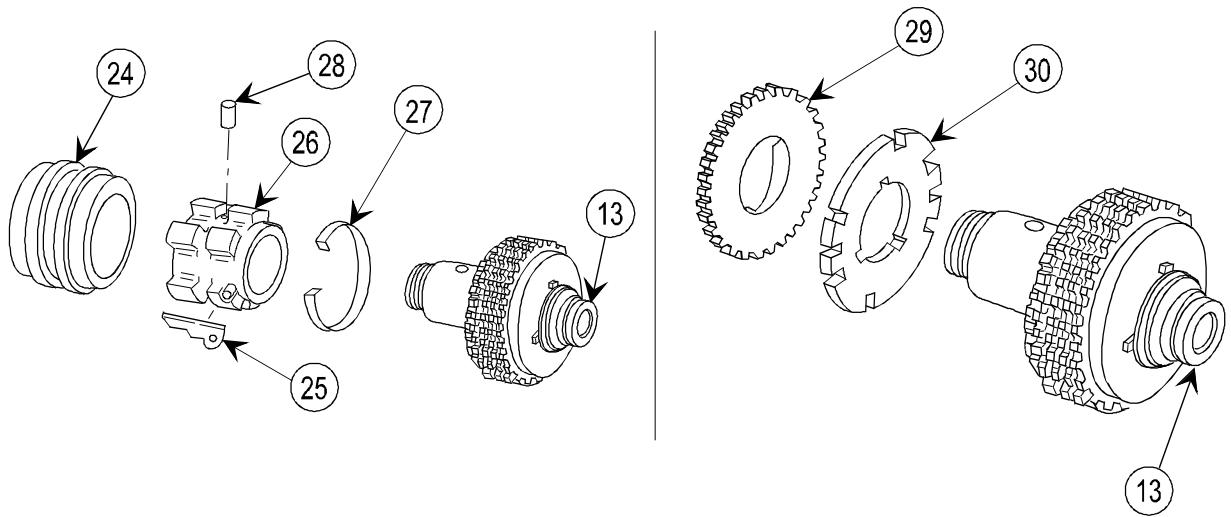

20 Remove shipper sleeve (24) and three dogs (25).

NOTE

Scribe line on clutch body (26) and rigid shaft coupling (13) to assist in reassembly.

21 Remove adjustment lock spring (27).

22 Drive out two anchor pins (28).

23 Remove clutch body (26) from rigid shaft coupling (13).

24 Remove adjustment collar (29) and pressure plate (30) from rigid shaft coupling (13).

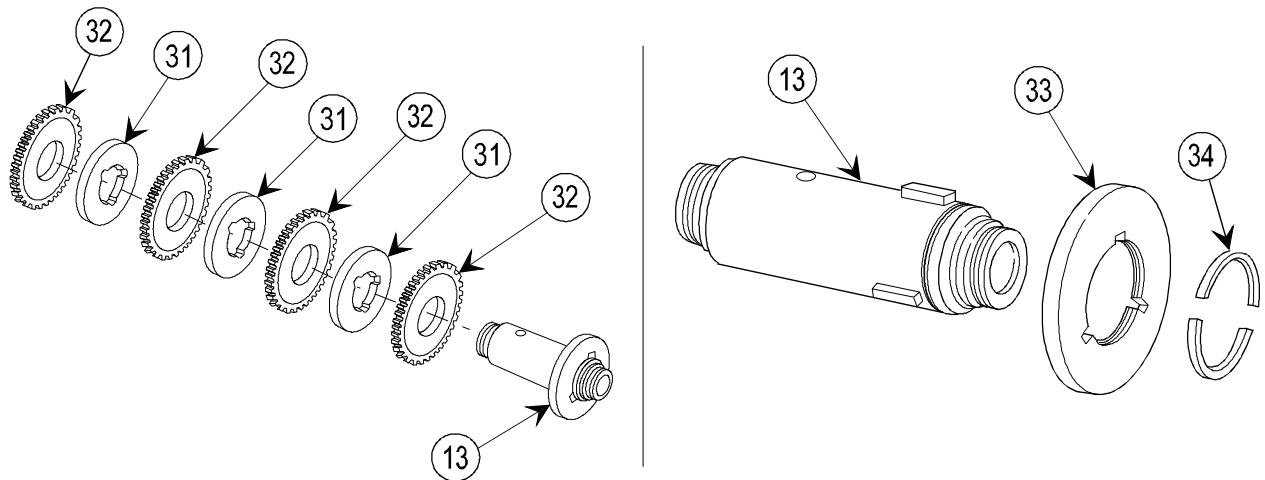

25 Remove three inner disks (31) and four outer disks (32).

26 Move thrust plate (33) slightly to clear split ring (34); remove split ring (34).

27 Remove thrust plate (33) from rigid shaft coupling (13).

INSPECTION/REPAIR

- 1 Check for broken, damaged, or missing parts.
- 2 Repair is by replacement of authorized parts (TM 9-1025-211-34P).

REASSEMBLY

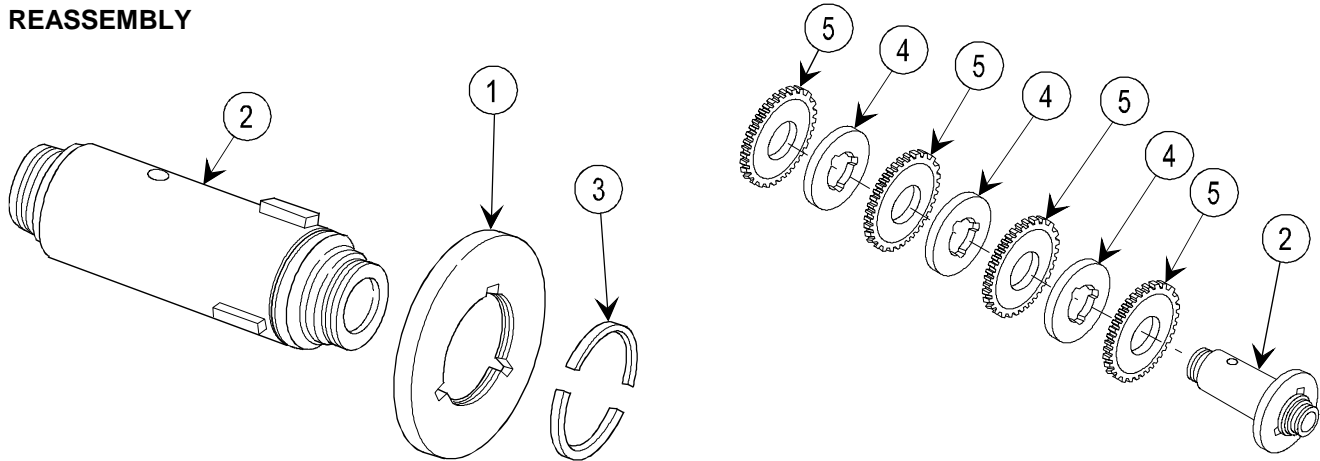

NOTE

Ensure counterbore in thrust plate faces split ring.

- 1 Install thrust plate (1) on rigid shaft coupling (2).
- 2 Install split ring (3) on rigid shaft coupling (2) and secure in place with counterbore of thrust plate (1).
- 3 Install three inner disks (4) and four outer disks (5) on rigid shaft coupling (2).

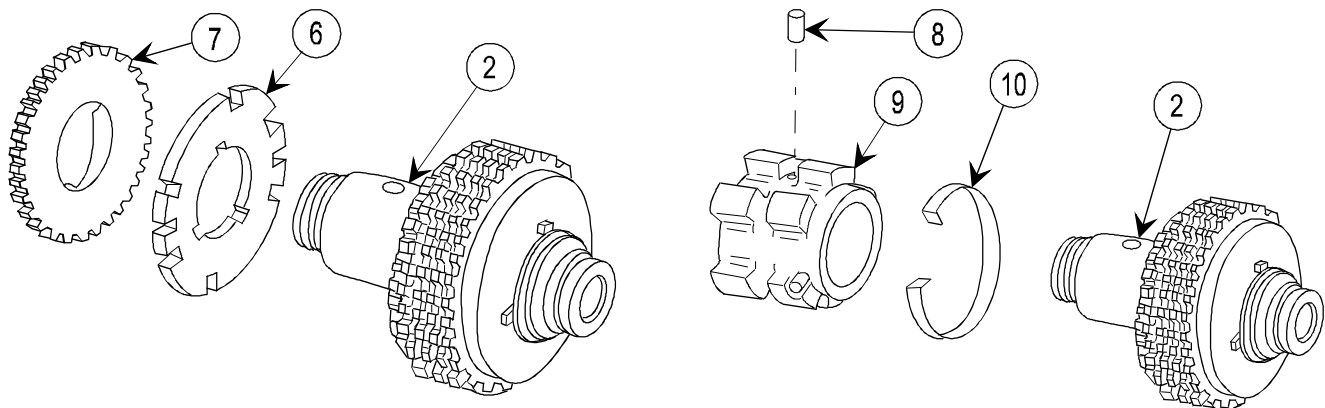

NOTE

If new anchor pin is used it must be modified at installation. Make two pins, as shown. Ensure that new anchor pins (8) do not protrude into spline of rigid shaft coupling (2) or groove in clutch body (9).

- 5 Install clutch body (9) and two new anchor pins (8). Aline scribe marks on clutch body and rigid shaft coupling (2).
- 6 Install adjustment lock spring (10).

2-31. FRICTION CLUTCH—MAINTENANCE INSTRUCTIONS (cont)

REASSEMBLY (cont)

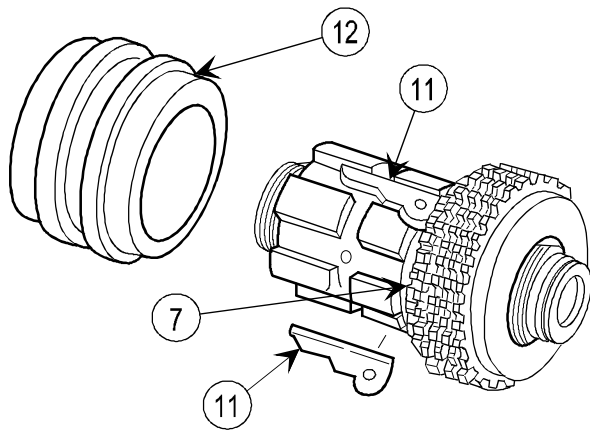

NOTE

Ensure dogs rest on the cam firmly and that the dogs are parallel to the raised portion of the clutch body.

If the dogs are not parallel to the raised portion of the clutch body, use lever to remove adjustment lock spring and turn adjustment collar until dogs are parallel with the raised portion of the clutch body. Place the adjustment lock spring in new position.

- 7 Apply thin coat of GMD grease to three dogs (11). Install three dogs (11).

NOTE

Shipper sleeve must be able to be pressed flush against adjustment collar (7). If not, clutch is out of adjustment.

- 8 Apply thin coat of GMD grease to inside of shipper sleeve (12). Install shipper sleeve.

NOTE

Seal threads of nuts, ring, and bearings diameter with sealing compound during reassembly.

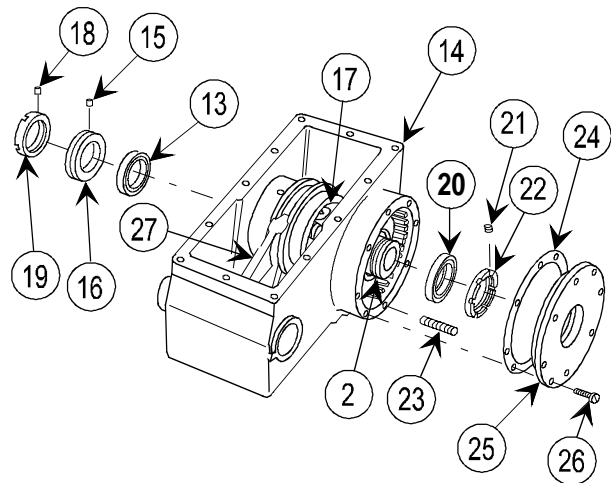

- 9 Pack ball bearing (13) with WTR grease. Install bearing (13) in housing (14).
- 10 Install new plastic molding (15) in externally threaded ring (16), and install ring in housing (14).
- 11 Install friction clutch (17) with attached parts in housing (14).
- 12 Install new plastic molding (18) in nut (19) and install nut on rigid shaft coupling (2).
- 13 Pack ball bearing (20) with WTR grease and install on shaft (2).
- 14 Install new plastic molding (21) in nut (22) and install nut on rigid shaft coupling (2).
- 15 Install eight inserts (23).
- 16 Install gasket (24) and fitting end (25).
- 17 Install eight screws (26). Torque screws to 10.00 to 16.00 in.-lb (1.13 to 1.80 N-m) and secure with lock wire.
- 18 Apply film of GMD grease to mating surfaces of shipper sleeve and shifter fork (27). Install shifter fork (27) in housing (14), engaging shipper sleeve.

NOTE

With shifter fork (27) installed and friction clutch in engaged position, shipper sleeve (12) must be flush against adjustment collar (28) before continuing.

A controlled amount of force may be necessary to make this adjustment. If this procedure cannot be done, check position of the dogs to the clutch body.

If this procedure continues to fail, the components may be faulty. Inspect parts for damage and wear. Repair is by replacement of authorized parts (TM 9-1025-211-34P) which do not meet inspection criteria.

- 19** Install two new preformed packings (29) inside two bushings (30 and 31).

NOTE

If new bushings are being installed continue with step 20; otherwise, proceed to step 24.

- 20** Install two new bushings (30 and 31).

NOTE

Shipper sleeve (12) must contact adjustment collar (28) (engaged position) for steps 21 thru 23.

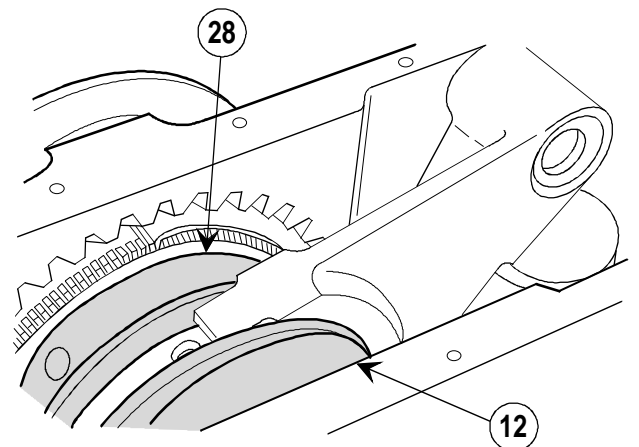
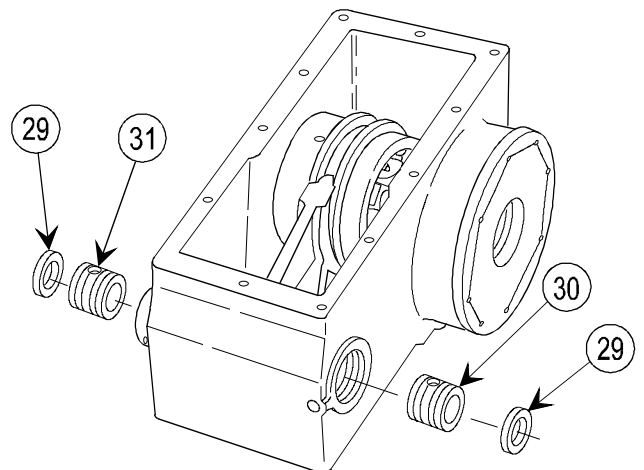
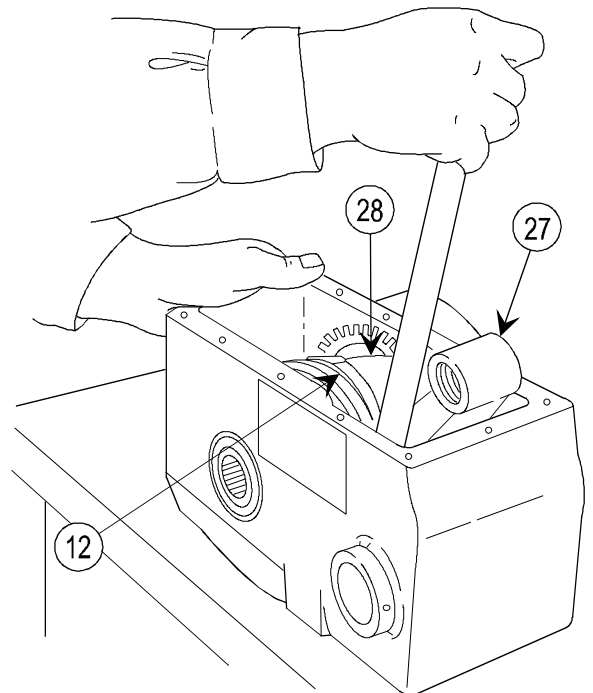

2-31. FRICTION CLUTCH—MAINTENANCE INSTRUCTIONS (cont)

REASSEMBLY (cont)

- 21** Hold suitable spacer in front of new bushing (30). Install bushing until there is 0.10 to 0.15 in. (0.25 to 0.38 cm) clearance (dimension A) between outer edge of shifter fork (27) and inner face of bushing (30). Lift shifter fork and remove suitable spacer.
- 22** Install new bushing (31). Check for 3.20 -0.20 in. (8.13 -0.51 cm) clearance (dimension B) between shifter fork (27) and bushing (31).

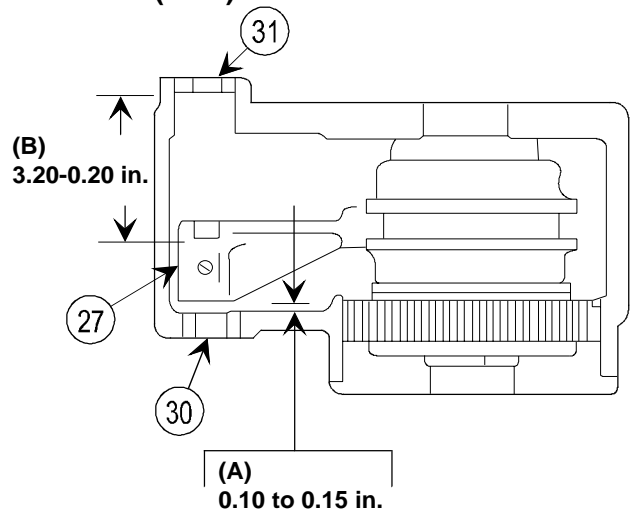

CAUTION

Do not drill through seal groove area of bushings.

- 23** Using 3/16-in. drill, drill 0.187 +0.005 in. (0.475 +0.013 cm) hole in bushings (30 and 31) through established holes in housing. Disassemble and remove burrs from inside of bushings.
- 24** Install bushings (30 and 31) making sure that pin holes in bushing align with holes in housing (16). Install two spring pins (32).
- 25** Install spring (33).
- 26** Apply a light film of GMD grease to sliding surfaces of rigid connecting link (34). Install through bushing (30), shifter fork (27), spring (33), and bushing (31).

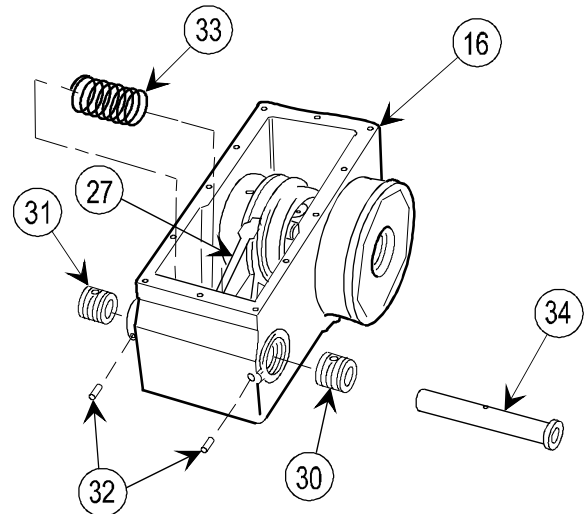

NOTE

If new rigid connecting link is being installed, proceed to step 27; otherwise proceed to step 29.

- 27** Set a dimension of 0.62 +0.02 in. (1.57 +0.05 cm) from face of housing (16) to inside face of rigid connecting link (34), as shown. Shipper sleeve (12) must contact adjustment collar (28) when making this adjustment.

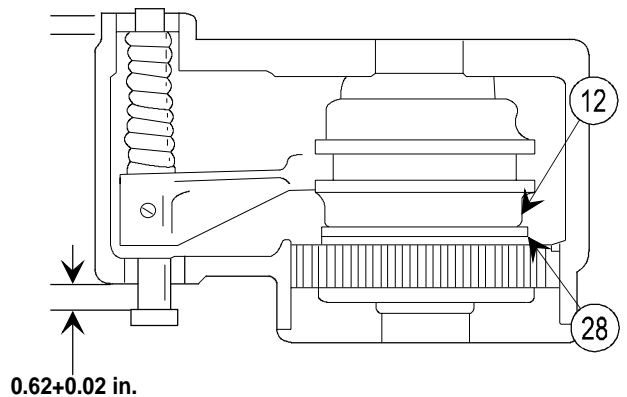

- 28 Using 3/16-in. drill, drill 0.187 +0.005 in. (0.475 +0.013 cm) hole through established hole in shifter fork (27).
- 29 Install spring pin (35) through shifter fork (27) and rigid connecting link (34).

NOTE

Fine adjustment of the friction clutch is done when the friction clutch is secured to workbench. Friction clutch adjustment is made by a series of trial adjustments.

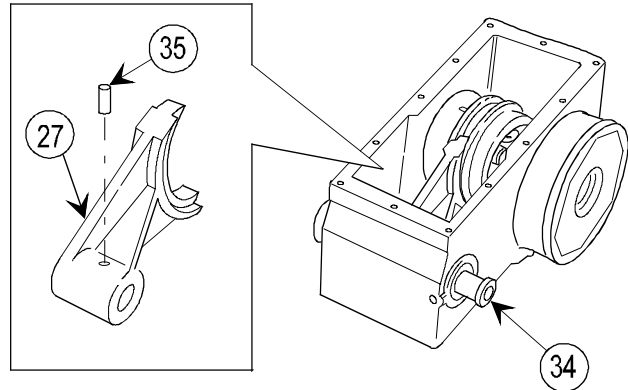

- 30 Measure holding torque of friction clutch (17).
- Place friction clutch in engaged position; shipper sleeve (12) will press flush against adjustment collar (28).
 - Install right straight shaft (36) or torque adapter in friction clutch, and connect torque wrench to free end of right straight shaft or torque adapter.
 - Measure holding torque. Properly adjusted friction clutch must hold a minimum torque of 230 ft-lb (312 N-m).

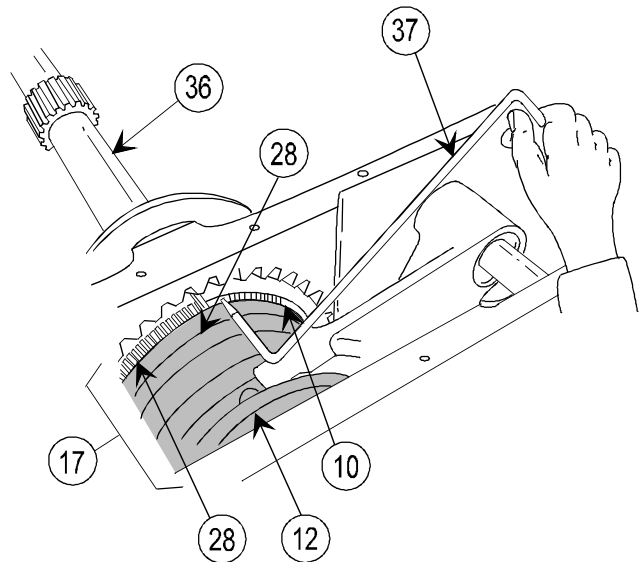

- 31 Adjust friction clutch (17).
- If adjustment is needed, shift to disengaged position.
 - Lift one end of adjustment lock spring (10) with lever (37).
 - Rotate adjustment collar (28) one tooth at a time. Clockwise rotation increases holding torque, and counterclockwise rotation reduces it.
 - Reengage adjustment lock spring (10).

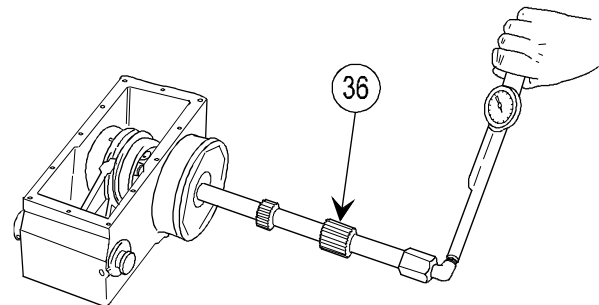

- Measure holding torque.
- Repeat steps 30 through 31e until proper torque is established.

2-31. FRICTION CLUTCH—MAINTENANCE INSTRUCTIONS (cont)

INSTALLATION

- 1 If removed, coat threaded inserts (1) and mating holes with primer and install while primer is wet.
- 2 Install friction clutch (2).
- 3 Install four lockwashers (3) and four bolts (4); do not tighten.

NOTE

When installing shafts (5) and (6), make sure dimensions recorded in disassembly are met.

- 4 Install left shaft (6) and attached parts by screwing in.
- 5 Install right shaft (5) and attached parts by screwing in.
- 6 Install two manual control levers (7) through two rod end plain bearings (8).
- 7 Install two torsion springs (9) on two manual control levers (7).
- 8 Install two manual control levers (7) into bracket assemblies (10) and control pivot arms (11).
- 9 Install two washers (12).
- 10 Install two new cotter pins (13).

NOTE

When installing shafts (14 and 15), keep rotation to a minimum until both shafts are installed. If excessive rotation occurs, the elevating ball screw assemblies may be thrown out of time and weapon will be difficult to elevate.

- 11 Install left straight shaft (15).
- 12 Install right straight shaft (14).

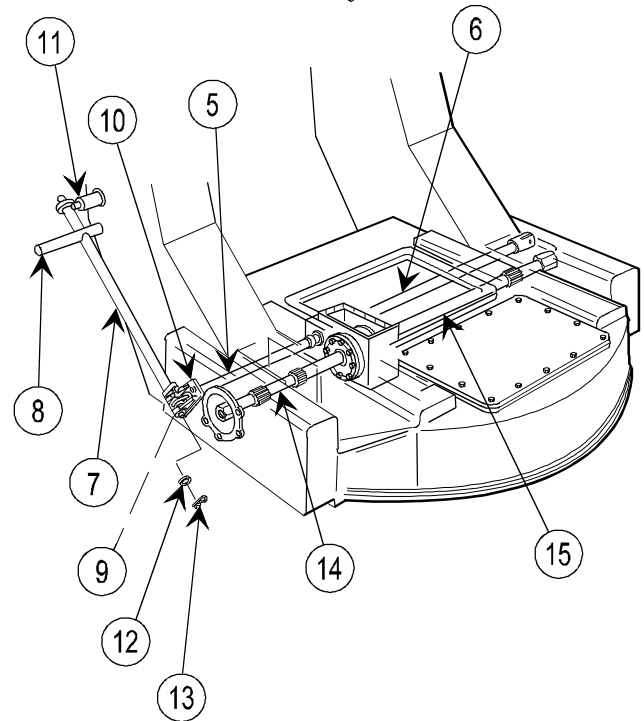
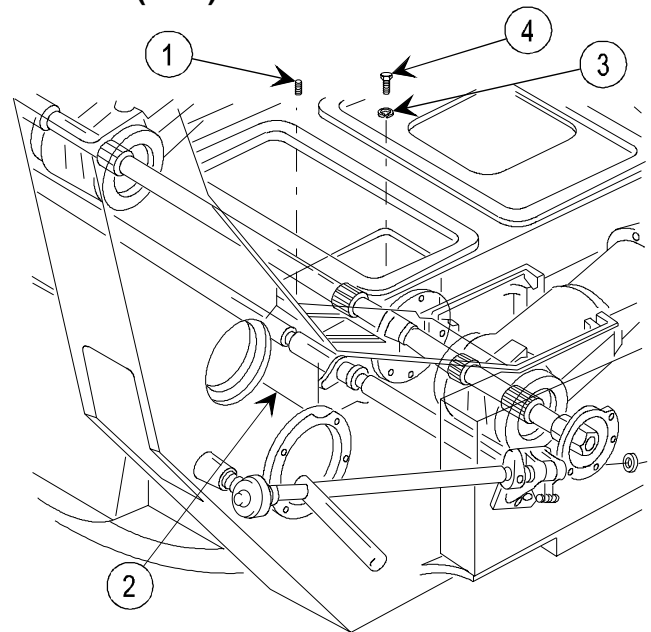

- 13 Torque four bolts (4) to 25.00 +5.00 ft-lb (33.75 +6.75 N-m).

NOTE

Laminated shims (16) must be adjusted as necessary to maintain alignment of elevating angle drive units (17).

- 14 Install two laminated shims (16) and two elevating angle drive units (17).
15 Install four flat washers (18), 12 lockwashers (19), and 12 bolts (20).

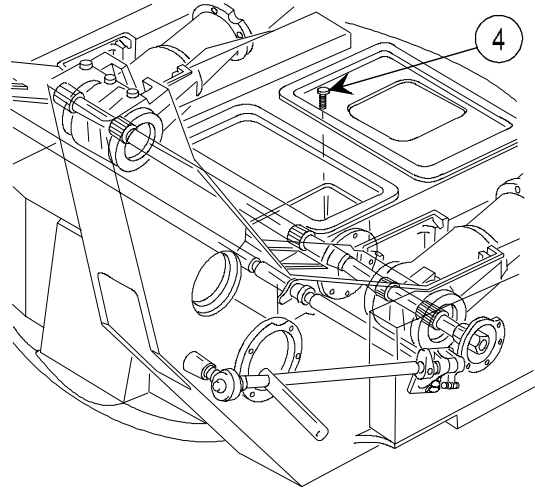

WARNING
Make sure cannon tube is supported by 3-ton hoist when performing visual inspection.

- 16 Operate two manual control levers (7) independently. Visually inspect shipper sleeve to make sure it contacts adjustment collar in the engaged position.

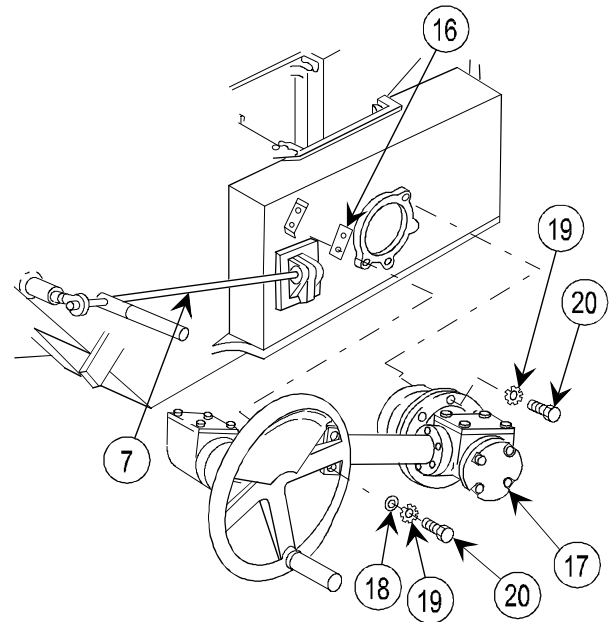

NOTE

Elevate/depress cannon tube to ensure there is no binding or chatter in elevating mechanism.

- 17 If removed, coat 12 threaded inserts (21) and mating holes with primer, and install while primer is still wet.
18 Install new gasket (22) and access cover (23).
19 Install 12 lockwashers (24) and 12 screws (25).

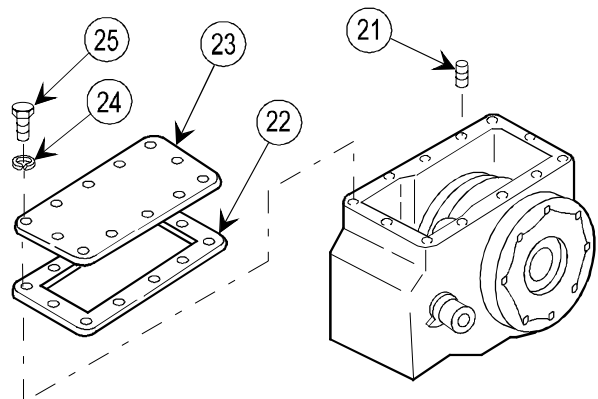

2-31. FRICTION CLUTCH—MAINTENANCE INSTRUCTIONS (cont)

INSTALLATION (cont)

NOTE

The second gasket (26) and standoff (27) are on modified howitzers only.

- 20 Install two new gaskets (26), standoff (27) and rear access cover (28).
- 21 Install 14 lockwashers (29) and 14 capscrews (30).

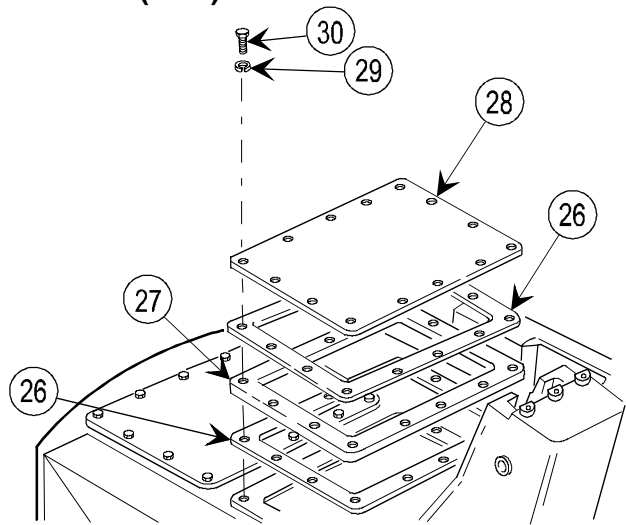

SERVICE

NOTE

Service is in conjunction with the disassembly and reassembly procedures. In order to perform service procedures, the friction clutch must be removed from the top carriage.

- 1 Drive out spring pin (1) through shifter fork (2) and rigid connecting link (3).
- 2 Remove rigid connecting link (3).
- 3 Remove spring (4).
- 4 Remove shifter fork (2). Clean with cleaning solvent.

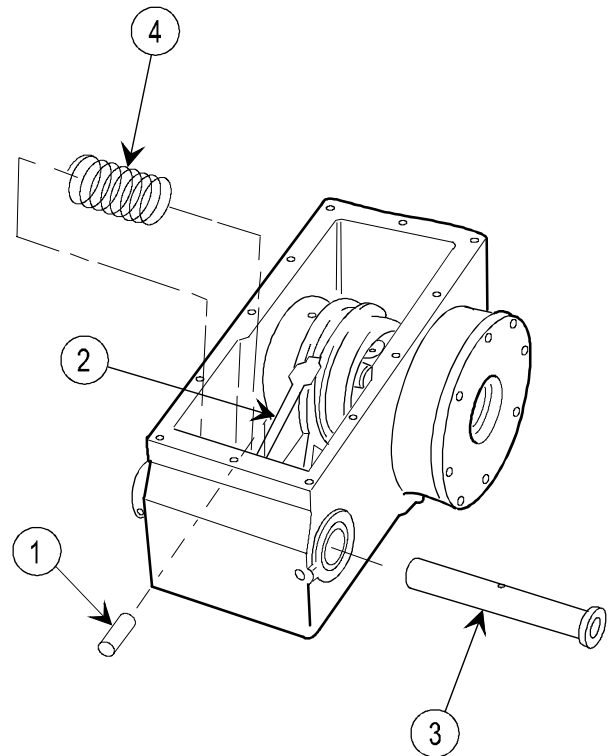

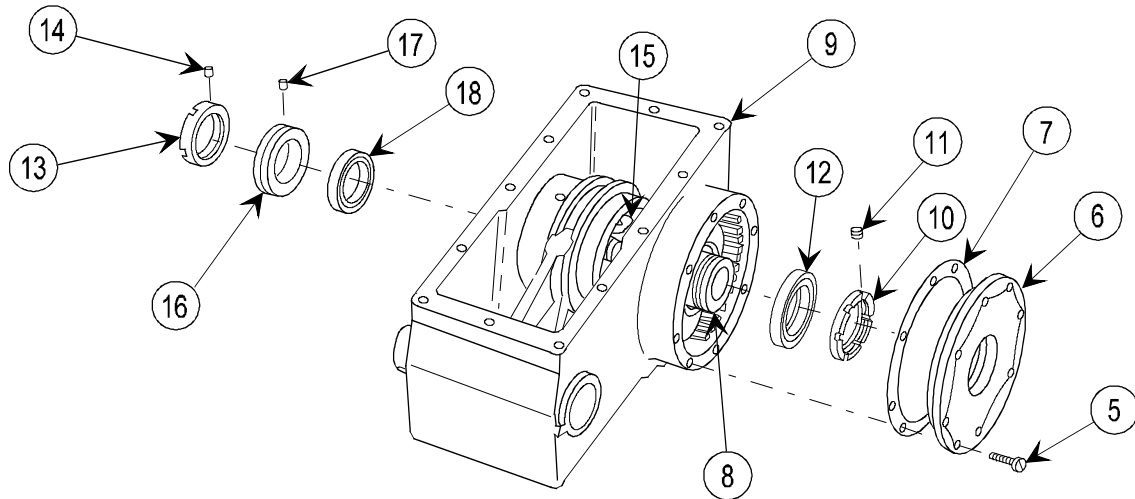

- 5 Remove lock wire and eight screws (5).
- 6 Remove fitting end (6) and gasket (7) from rigid shaft coupling (8) and housing (9). Check gasket for tears or deterioration; replace if necessary.
- 7 Remove nut (10) with spanner wrench from rigid shaft coupling (8).
- 8 Remove plastic molding (11) from inside nut (10).
- 9 Remove ball bearing (12). Check for evidence of failure or excessive wear; replace if necessary.
- 10 Remove nut (13).
- 11 Remove plastic molding (14) from inside nut (13).
- 12 Remove friction clutch (15) with attached parts.
- 13 Remove externally threaded ring (16).
- 14 Remove plastic molding (17) from inside externally threaded ring (16).
- 15 Remove ball bearing (18). Check for evidence of failure or excessive wear; replace if necessary.

WARNING

Cleaning solvent is toxic and flammable. Use in well-ventilated area. Avoid breathing the vapors and keep away from ignition sources.

- 16 Remove shipper sleeve (19) and three dogs (20) from friction clutch and attached parts. Soak in cleaning solvent to remove old grease buildup. A fine abrasive cloth or brush may aid in removal of corrosion located in the inner diameter.

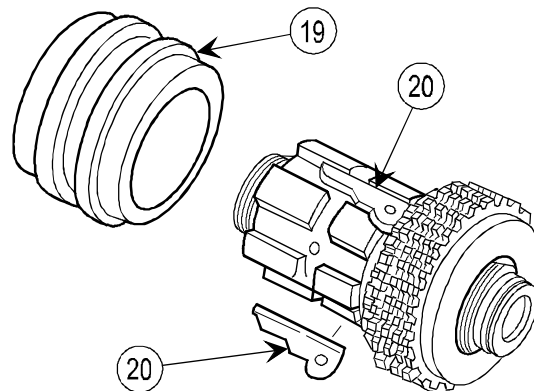

2-31. FRICTION CLUTCH—MAINTENANCE INSTRUCTIONS (cont)

SERVICE (cont)

CAUTION

Do not get solvent on any part of the friction clutch and attached parts other than the dogs (20) and clutch body (21). Particularly avoid the three inner disks (22) and four outer disks (23), or damage to parts could result.

- 17 Clean clutch body (21) with cleaning solvent.

CAUTION

Surfaces in contact with four outer disks (23) must be kept clean and dry.

- 18 Apply a thin film of GMD grease to the areas listed below.

- a. Sliding surfaces between shipper sleeve inner dimension and clutch body (21) and dogs (20).
- b. Sliding surfaces between shipper sleeve (19) and shifter fork (2).
- c. Sliding surfaces of rigid connecting link (3).

- 19 Install three dogs (20).

NOTE

Shipper sleeve must be able to be pressed flush against adjustment collar (24). If not, friction clutch is out of adjustment.

- 20 Install shipper sleeve (19).

NOTE

Seal threads of nuts, ring, and bearings diameter with sealing compound during reassembly.

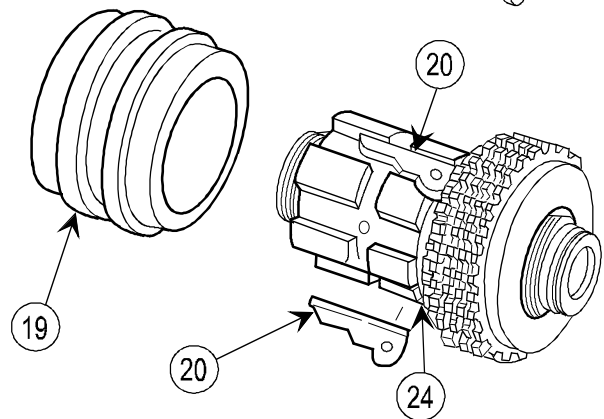
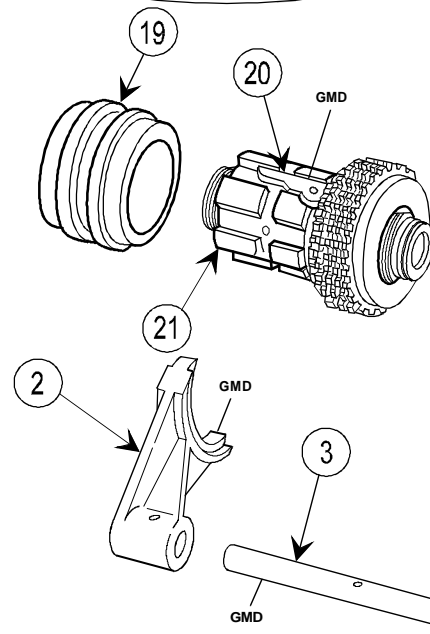
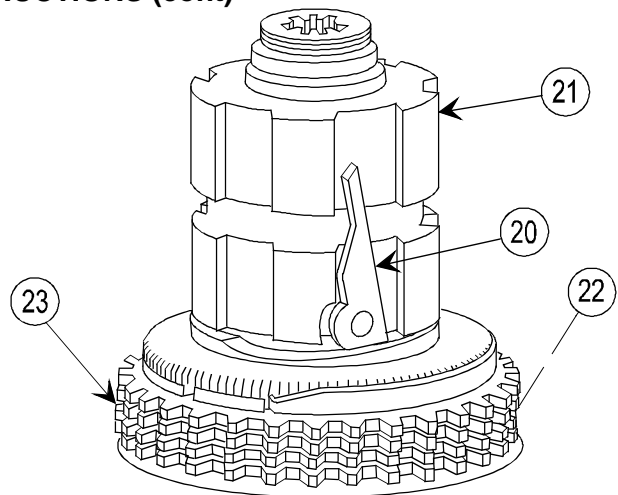

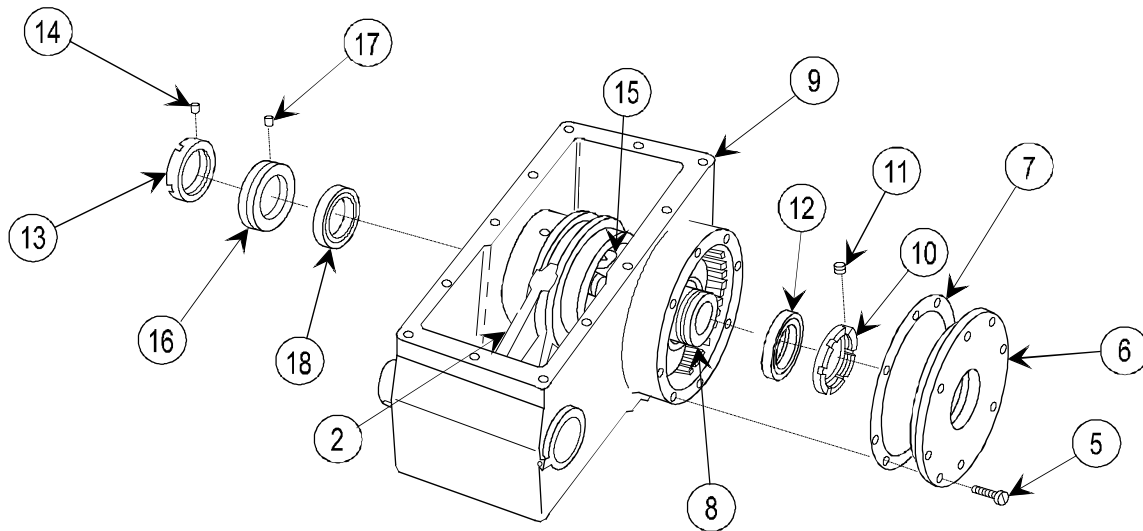

- 21** Pack ball bearing (8) with WTR grease and install.
- 22** Install new plastic molding (17) in externally threaded ring (16); install externally threaded ring in housing (9).
- 23** Install friction clutch (15) with attached parts.
- 24** Install new plastic molding (14) in nut (13); install nut on rigid shaft coupling (8).
- 25** Pack ball bearing (12) with WTR grease and install.
- 26** Install new plastic molding (11) in nut (10); install nut on rigid shaft coupling (8).
- 27** Install gasket (7) and fitting end (6).
- 28** Install eight screws (5); torque screws to 10.00 16.00 in.-lb (1.13 to 1.80 N-m) and secure with lock wire. Apply GMD grease to machined surfaces that mate to shipper sleeve.
- 29** Install shifter fork (2) in housing (9), engaging shipper sleeve.

2-31. FRICTION CLUTCH—MAINTENANCE INSTRUCTIONS (cont)

SERVICE (cont)

NOTE

With shifter fork (2) installed and friction clutch in locked position, shipper sleeve (19) must be flush against adjustment collar (24) before continuing.

A controlled amount of force may be necessary to make this adjustment. If this procedure cannot be done, check position of dogs to the clutch body.

If this procedure continues to fail, components may be faulty. Inspect parts for damage and wear. Repair is by replacement of authorized parts (TM 9-1025-211-34P) which do not meet inspection criteria.

- 30 Install spring (4).
- 31 Apply a light film of GMD grease to sliding surfaces of rigid connecting link (3); install through bushing (25), shifter fork (2), spring (4), and bushing (26).
- 32 Install spring pin (1) through shifter fork (2) and rigid connecting link (3).
- 33 Measure holding torque (p 2-213). Adjust if necessary.

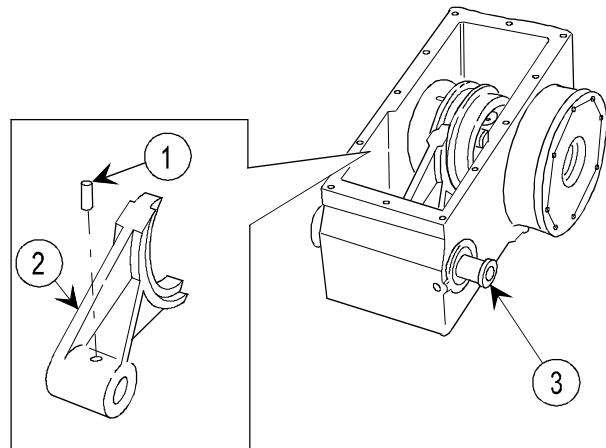
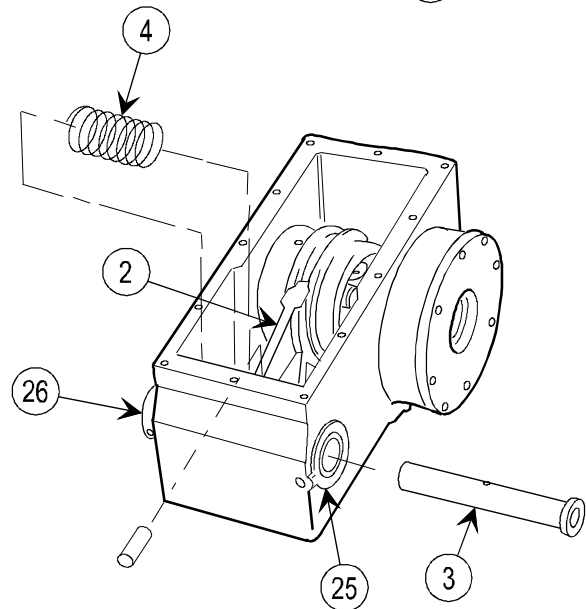
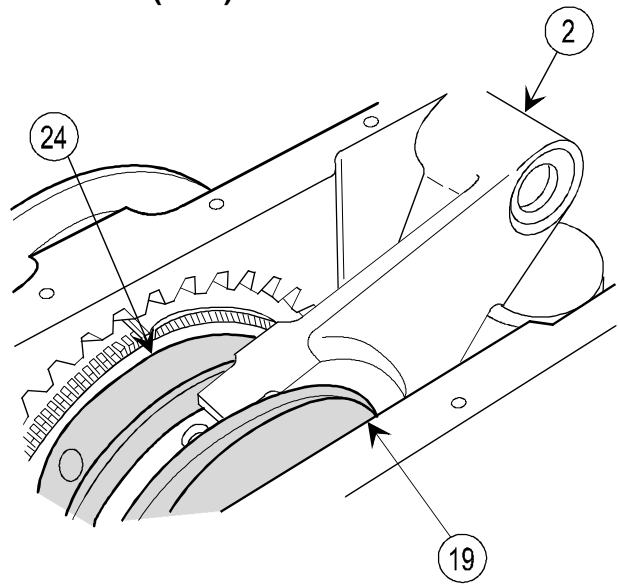

2-33. TRAVERSING DRIVE UNIT—MAINTENANCE INSTRUCTIONS

THIS TASK COVERS:

- | | | |
|---------------|-----------------|----------------------|
| a. Removal | b. Disassembly | c. Inspection/repair |
| d. Reassembly | e. Installation | |

INITIAL SETUP

Tools and Special Tools

- Artillery and turret mechanic's ordnance tool kit (SC 5180-95-CL-A12)
- Artillery field maintenance shop equipment (SC 4933-95-CL-A12)

Materials/Parts

- Gasket (12008202)
- Lock wire (item 34, appx B)
- Seal (MS51001-11-3)
- WTR grease (item 11, appx B)

Personnel Required: 2

References

TM 9-1025-211-34P

Equipment Conditions

- 2-221 Traversing handwheel removed
- 2-242 Rear access cover of top carriage assembly removed

REMOVAL

NOTE

Bellows on traversing drive universal joints are on modified howitzers only. It may be necessary to loosen clamps (1) prior to removal of traversing drive unit.

- 1 Remove lock wire (2), five bolts (3), and five washers (4).

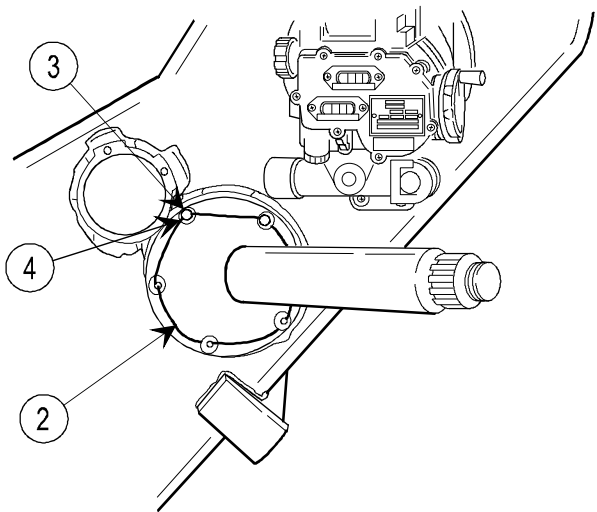

- 2 Remove traversing drive unit (5) by sliding out of top carriage assembly (6).
- 3 Remove gasket (7).

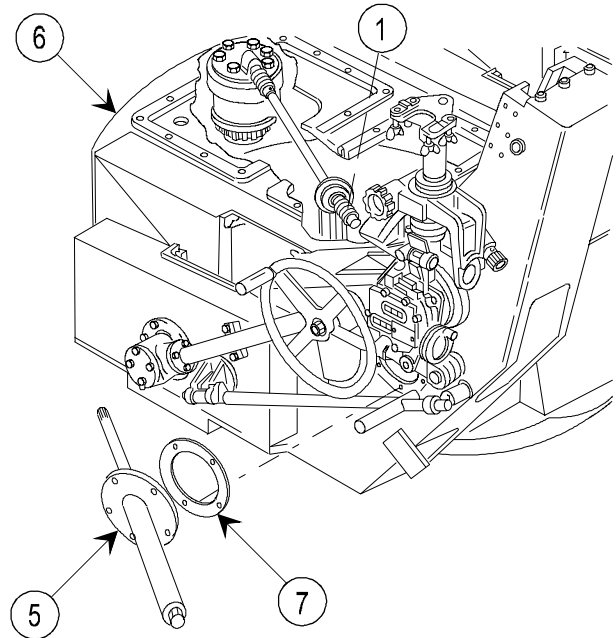

DISASSEMBLY

- 1 Loosen two screws (1) on clamps (2); move clamps and bellows (3) away from universal joint.
- 2 Remove spring pin (4) from straight shaft (5) and universal joint (6).
- 3 Remove straight shaft (5).
- 4 Remove key (7) from straight shaft (5).
- 5 Remove spring pin (8) and universal joint (6).

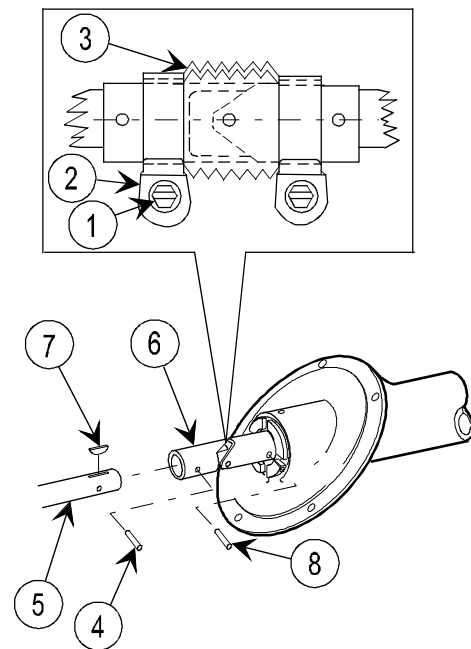

- 6 Remove key (9) from shouldered shaft (10).
- 7 Remove setscrew (11) from housing (12).

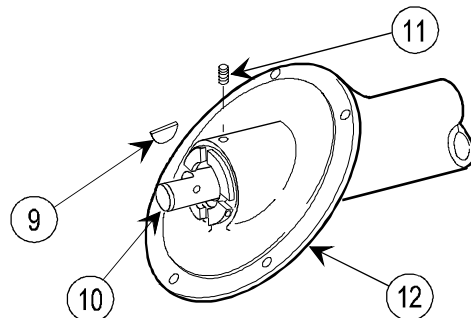

2-33. TRAVERSING DRIVE UNIT—MAINTENANCE INSTRUCTIONS (cont)

DISASSEMBLY (cont)

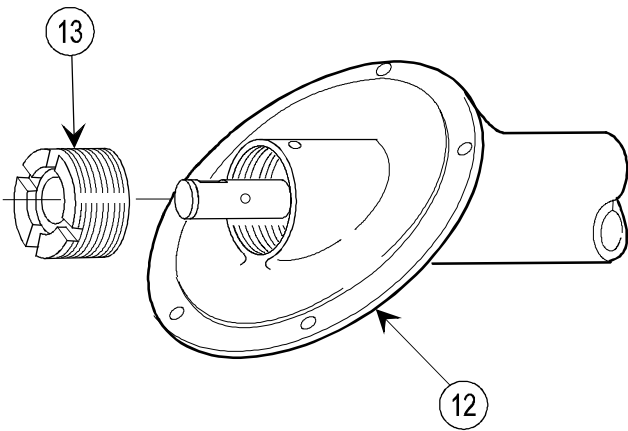

8 Remove ring (13) from housing (12).

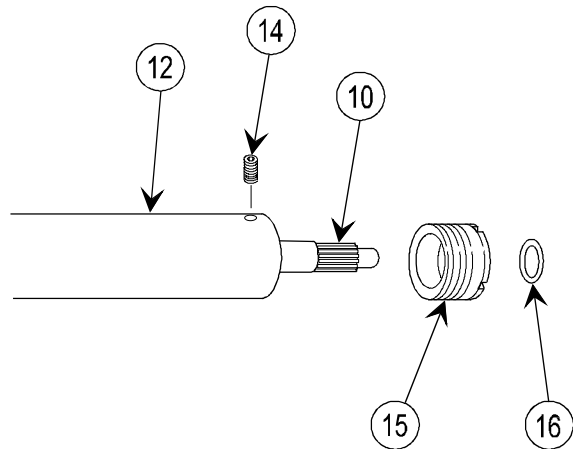

9 Remove setscrew (14) from housing (12).

10 Remove ring (15) and seal (16) from housing (12).

11 Remove shouldered shaft (10) from housing (12).

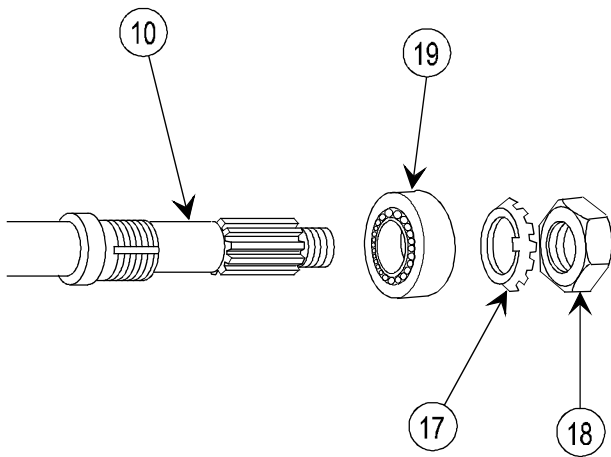

NOTE

Tabs of key washer (17) must be bent away from nut (18) for removal.

12 Remove nut (18), key washer (17), and bearing (19) from shouldered shaft (10).

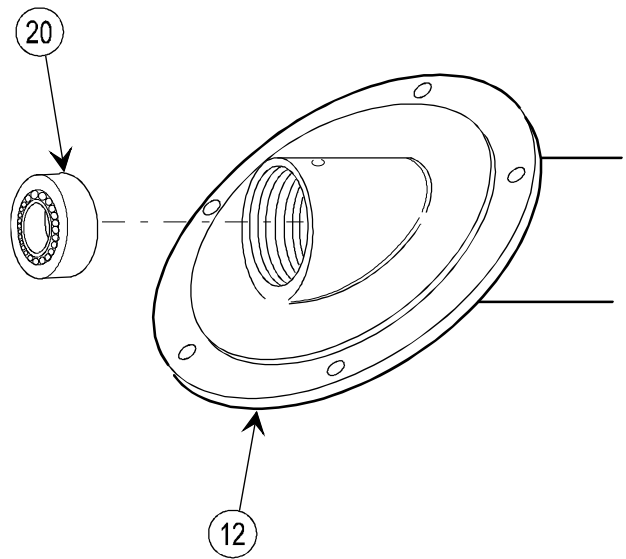

13 Remove bearing (20) from housing (12).

INSPECTION/REPAIR

- 1 Check for any broken, damaged, or missing parts.
- 2 Repair is by replacement of authorized parts (TM 9-1025-211-34P).

REASSEMBLY

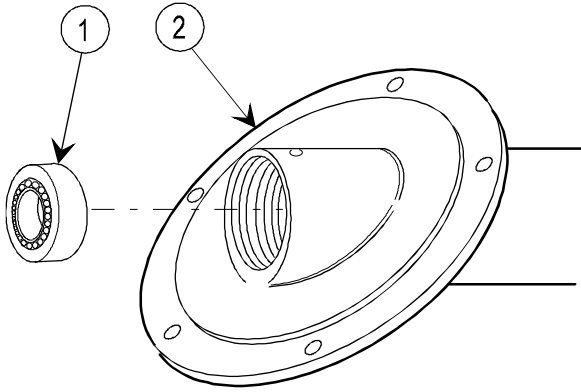

- 1 Repack bearing (1) with WTR grease; install in housing (2) with seal facing outward.

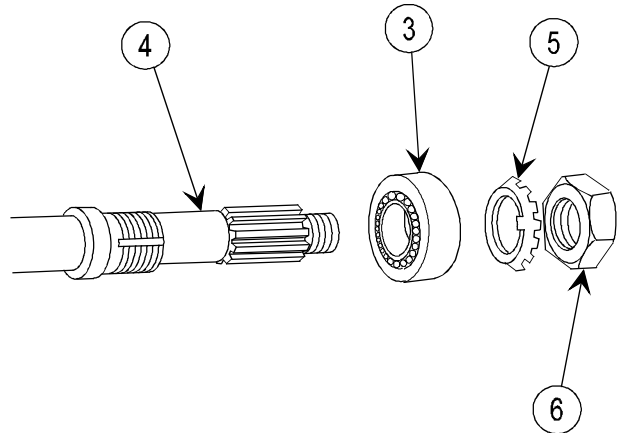

- 2 Repack bearing (3) with WTR grease; install on shouldered shaft (4) with seal facing outward.
- 3 Install key washer (5).
- 4 Install nut (6) and torque 70.0 to 90.0 in.-lb (7.8 to 10.1 N-m).
- 5 Bend tabs of key washer (5) around nut (6).

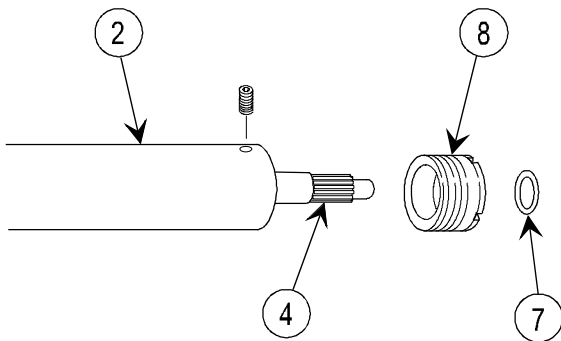

- 6 Install shouldered shaft (4) in housing (2).
- 7 Install new seal (7) and ring (8) in housing (2).

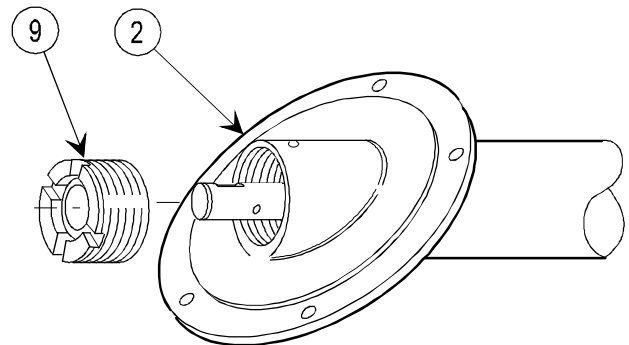

- 8 Install ring (9) in housing (2).

2-33. TRAVERSING DRIVE UNIT—MAINTENANCE INSTRUCTIONS (cont)

REASSEMBLY (cont)

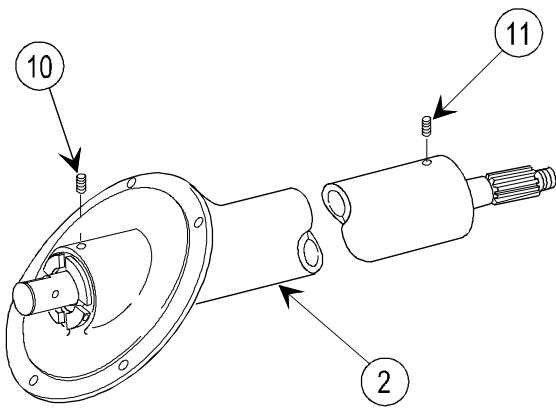

9 Install setscrews (10 and 11) in housing (2).

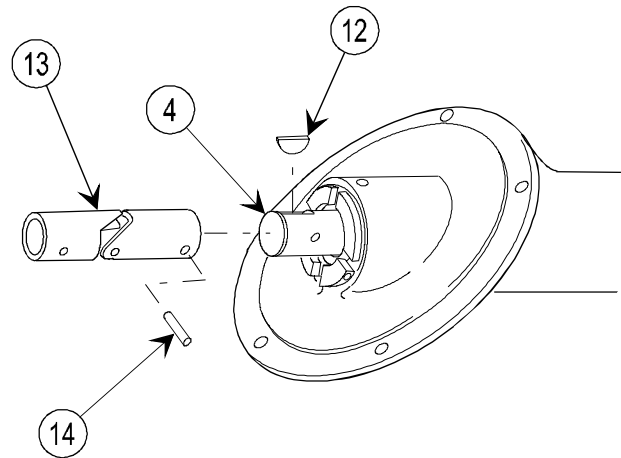

10 Install key (12) in shouldered shaft (4).

11 Install one end of universal joint (13) over shouldered shaft (4).

12 Install spring pin (14) in shouldered shaft (4) and universal joint (13).

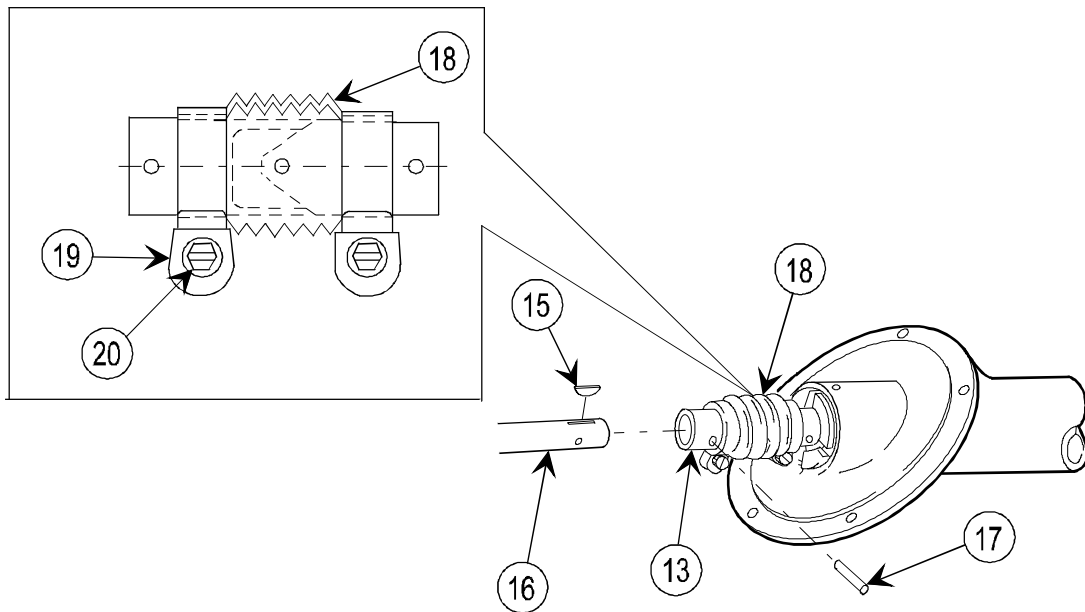

13 Install key (15) in straight shaft (16).

14 Install straight shaft (16) in universal joint (13).

15 Install spring pin (17) in universal joint (13).

16 Apply WTR grease as required prior to final clamping of bellows.

17 Install bellows (18) and two clamps (19); tighten screws (20).

INSTALLATION

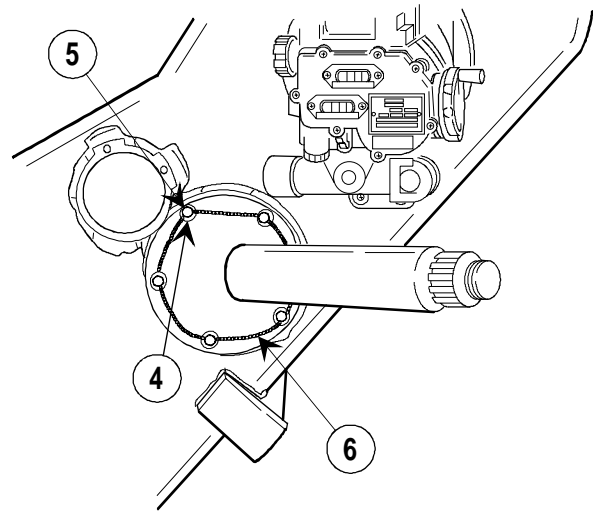
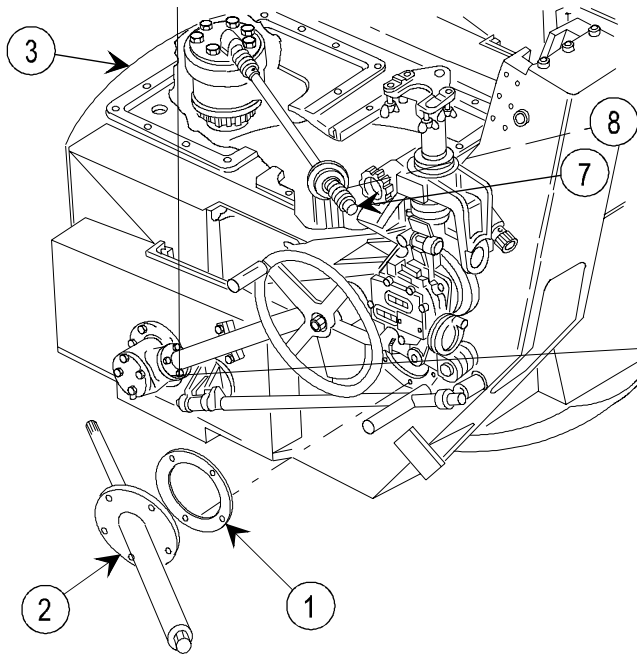

- 1 Install new gasket (1) and traversing drive unit (2) in universal joint of traversing shaft assembly on top carriage assembly (3).
- 2 Install five washers (4), five bolts (5), and lock wire (6).
- 3 Reposition bellows (7), and tighten clamps (8).

2-34. TRAVERSING SHAFT ASSEMBLY—MAINTENANCE INSTRUCTIONS

THIS TASK COVERS:

- | | | |
|----------------------|----------------|-----------------|
| a. Removal | b. Disassembly | c. Adjustment |
| d. Inspection/repair | e. Reassembly | f. Installation |

INITIAL SETUP

Tools and Special Tools

Artillery and turret mechanic's ordnance tool kit (SC 5180-95-CL-A12)
Artillery field maintenance shop equipment (SC 4933-95-CL-A12)

Materials/Parts

Gasket (4) (12008273)
Primer (item 19, appx B)
WTR grease (item 11, appx B)

References

TM 9-1025-211-34P

Equipment Conditions

2-222 Traversing drive unit removed

2-34. TRAVERSING SHAFT ASSEMBLY—MAINTENANCE INSTRUCTIONS (cont)

REMOVAL

- 1 Remove 28 capscrews (1) and 28 lockwashers (2).
- 2 Remove two access covers (3), four gaskets (4), and two standoffs (5).

NOTE

Second gasket (4), standoff (5), and bellows (6) apply to modified howitzers only.

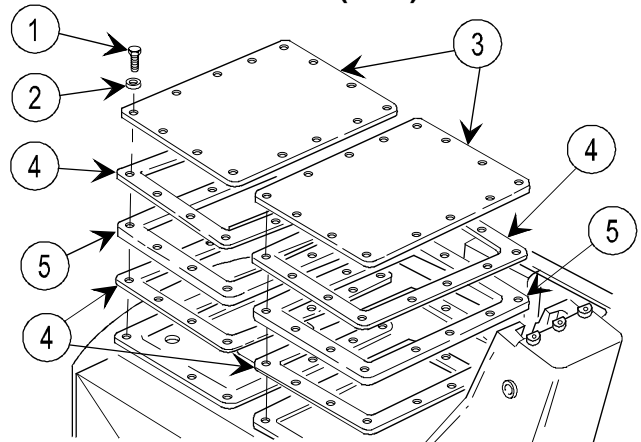

- 3 Loosen two screws (7) on clamps (8); move clamps (8) and bellows (6) away from universal joint.
- 4 Remove spring pin (9).
- 5 Remove three capscrews (10) and three lockwashers (11).

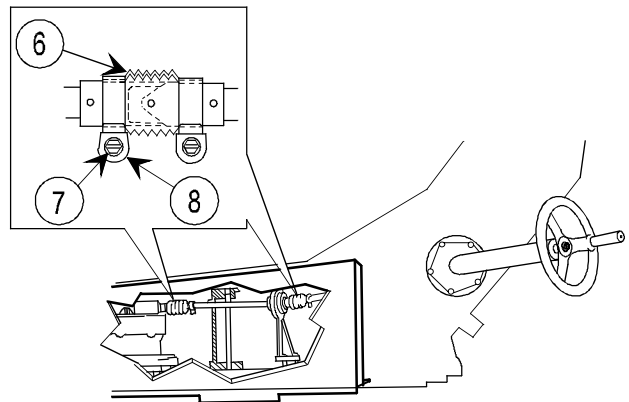

- 6 Remove traversing shaft assembly (12).
- 7 Remove key (13).
- 8 Remove shim (14).

CAUTION

Removing threaded insert may cause damage. Do not remove unless necessary for replacement of authorized parts.

- 9 Remove three inserts (15) only if corroded or damaged.

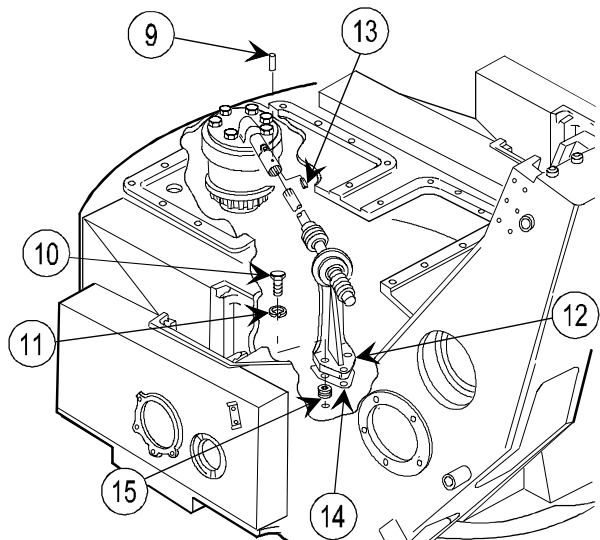

DISASSEMBLY

NOTE

Procedures for removal of bellows apply to modified howitzers only.

- 1 Move clamps (1) and bellows (2) away from universal joint (3).
- 2 Remove spring pin (4) from universal joint (3).
- 3 Remove universal joint (3) from straight shaft (5).
- 4 Remove setscrew (6) from torque limiter (7).
- 5 Remove straight shaft (5) and key (8).

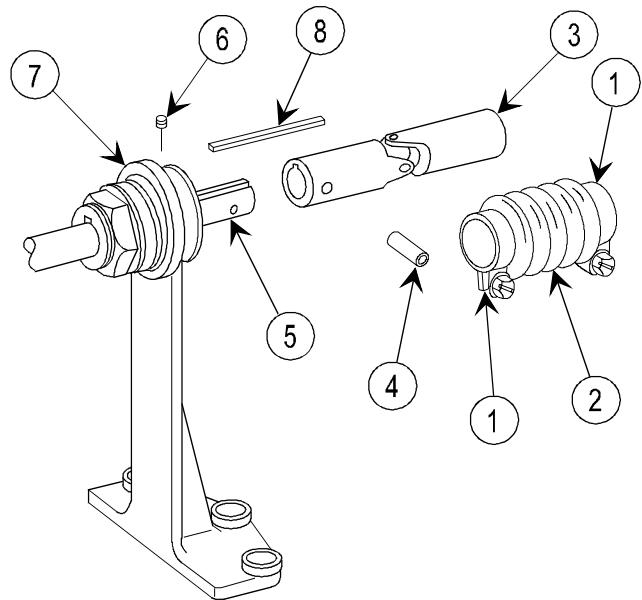

ADJUSTMENT

NOTE

Bracket (1) should be secured in a vise or clamped to a suitable support while adjustment is being made. During assembly, make certain one friction plate goes on each side of bracket. Make sure torque limiter (2) and attaching parts are free of oil and grease.

- 1 Measure torque that must be applied to nut (3) to rotate torque limiter in bracket (1).

NOTE

If measured torque is 25.0 in.-lb (2.8 N-m), torque limiter is properly adjusted and steps 2 thru 6 may be omitted.

- 2 Bend tab (4) on lockwasher (5) away from nut (3). If your configuration has a setscrew instead of a lockwasher, loosen setscrew.
- 3 Insert key (6) and shaft (7) into torque limiter (2).

NOTE

Nut (3) must be tightened to increase torque or loosened to reduce torque.

- 4 Adjust nut (3) while holding torque limiter (2) with shaft (7).

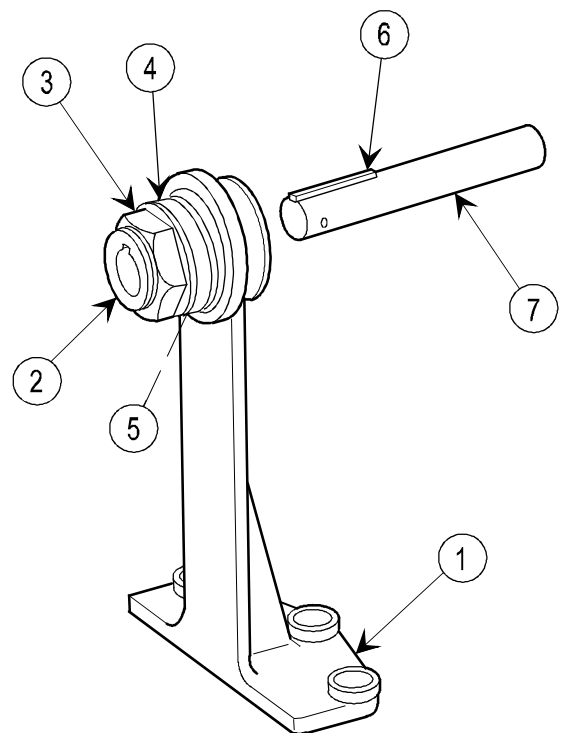

- 5 Remove shaft (7) and key (6).
- 6 Bend tab (4) over nut (3) to lock, or tighten setscrew.

NOTE

Repeat steps 1 thru 6 as required until 25.0 in.-lb (2.8 N-m) adjustment is obtained.

2-34. TRAVERSING SHAFT ASSEMBLY—MAINTENANCE INSTRUCTIONS (cont)

INSPECTION/REPAIR

- 1 Check for broken, damaged, or missing parts.
- 2 Repair is by replacement of authorized parts (TM 9-1025-211-34P).

REASSEMBLY

NOTE

Procedures for installation of bellows apply to modified howitzers only.

- 1 Install key (1) and straight shaft (2).
- 2 Install universal joint (3) and spring pin (4).
- 3 Install setscrew (5) but do not tighten.

NOTE

Setscrew (5) is tightened after the traversing shaft assembly is installed in the carriage.

- 4 Apply WTR grease to universal joint (3) prior to clamping of bellows.
- 5 Install bellows (6) and two clamps (7) on universal joint; install but do not tighten two screws (8). (Bellows will be repositioned and clamps tightened after the traversing drive unit is installed.)

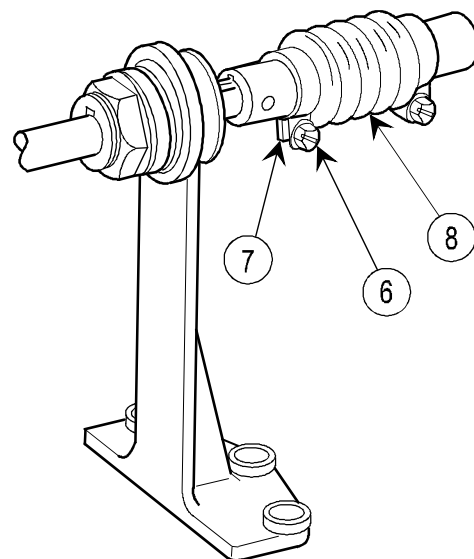
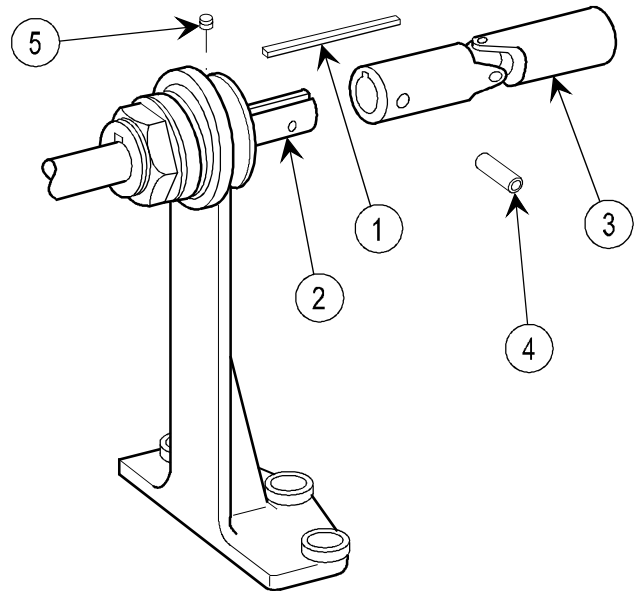

INSTALLATION

- 1 Install bellows (1) and clamps (2) on straight shaft (3), but do not tighten.

NOTE

Procedures for installation of bellows apply to modified howitzers only.

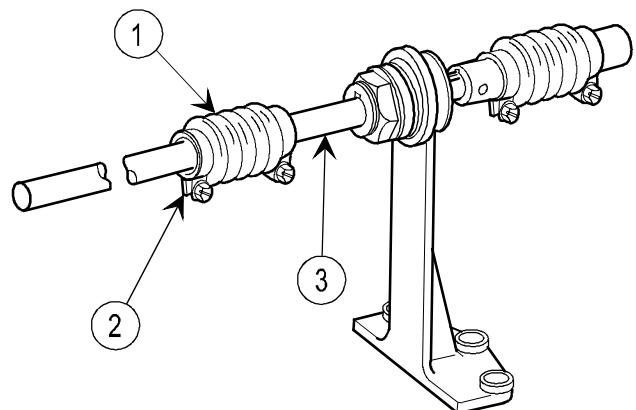

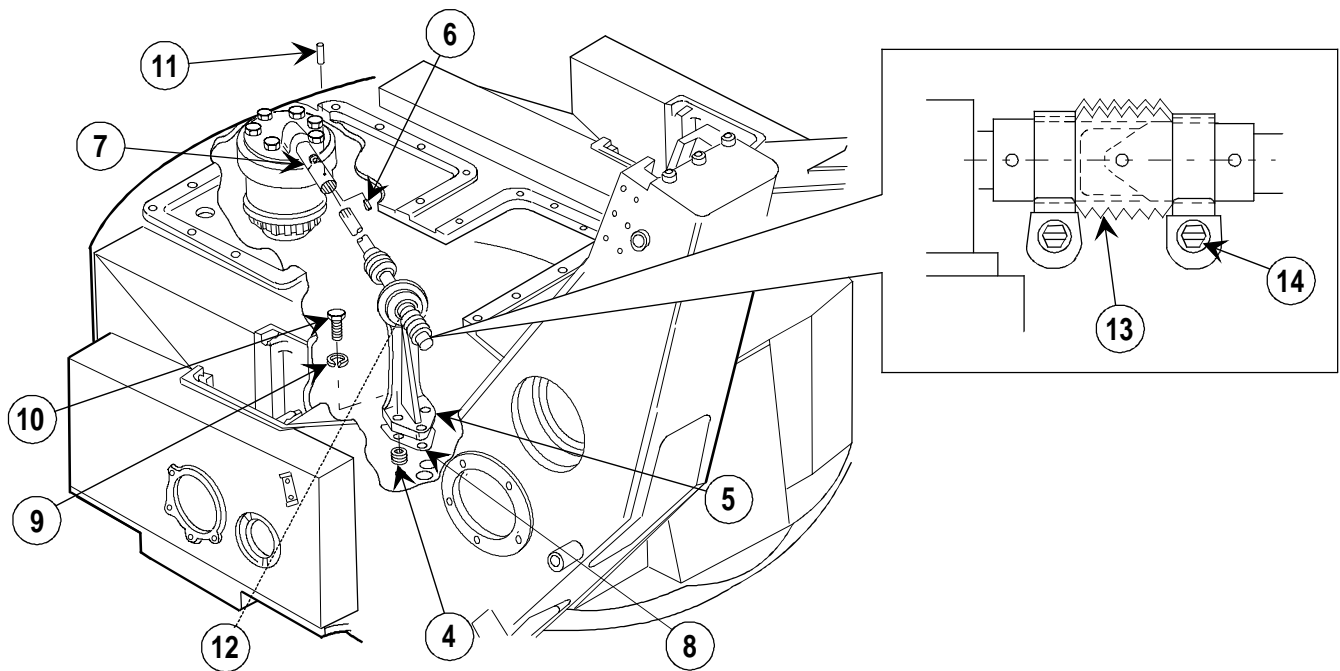

- 2 Coat three inserts (4) and mating holes with primer and install while primer is wet.
- 3 Install traversing shaft assembly (5) with key (6) to universal joint (7).
- 4 Install shim (8).
- 5 Install three lockwashers (9) and three cap screws (10), and torque to 30.0 ft-lb (40.5 N-m).
- 6 Install spring pin (11)
- 7 Tighten setscrew (12).
- 8 Apply WTR grease to universal joints (7 and 13) prior to final clamping of bellows. Position bellows over universal joint and tighten two screws (14).

NOTE

Second gasket (15) and standoff (16) are on modified howitzers only.

- 9 Install four new gaskets (15), two standoffs (16), and two access covers (17).
- 10 Install 28 new lockwashers (18) and 28 cap screws (19).

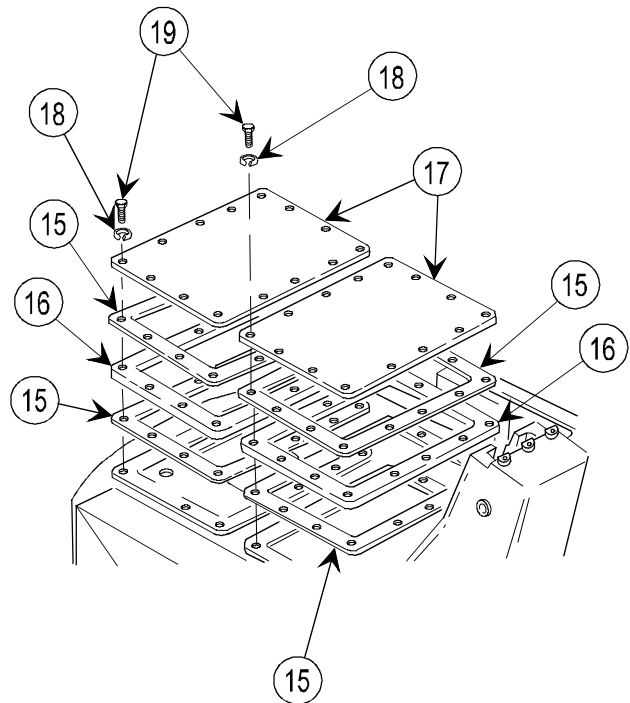

2-35. TRAVERSING ANGLE DRIVE UNIT—MAINTENANCE INSTRUCTIONS

THIS TASK COVERS:

- | | | |
|---------------|-----------------|----------------------|
| a. Removal | b. Disassembly | c. Inspection/repair |
| d. Reassembly | e. Installation | f. Adjustment |
| g. Service | | |

INITIAL SETUP

Tools and Special Tools

Artillery and turret mechanic's ordnance tool kit (SC 5180-95-CL-A12)
Artillery field maintenance shop equipment (SC 4933-95-CL-A12)
Dial indicator (MIL-I-18422)
M198 repairman field artillery tool kit (5911278)
Surface gage (GGG-G-17)

Materials/Parts

Lock wire (item 34, appx B)
Lock wire (item 35, appx B)
Oil (hydraulic fluid) (item 14, appx B)
WTR grease (item 11, appx B)

Personnel Required: 2

Artillery mechanic
Welder

References

TM 9-1025-211-10 (appx F)
TM 9-1025-211-34P

Equipment Conditions

2-227 Traversing shaft assembly removed
Weapon elevated to 600 mils (TM 9-1025-211-10)

REMOVAL

NOTE

Bellows shown removed for clarity (modified howitzers only).

Traversing angle drive unit need not be removed for replacement of bevel gears or for adjustment of adjusting ring.

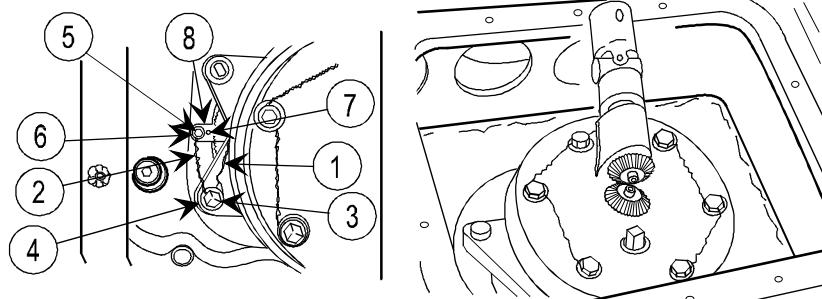

- 1 Remove lock wire (1 and 2), three screws (3), three washers (4), capscrew (5), and washer (6).
- 2 Install capscrew (5) into threaded hole (7). Remove stop (8) and capscrew (5).

- 3 Remove spring pin (9) and universal joint (10) with key (11).
- 4 Scribe a line on adjusting ring (12) and top carriage (13).

WARNING
Traversing angle drive unit is heavy. Use two personnel to lift, or injury to personnel may result.

NOTE
When removing traversing angle drive unit, adjusting ring may remain with unit.

- 5 Remove traversing angle drive unit (14) by lifting straight up.

- 6 Remove key (15) and adjusting ring (12).

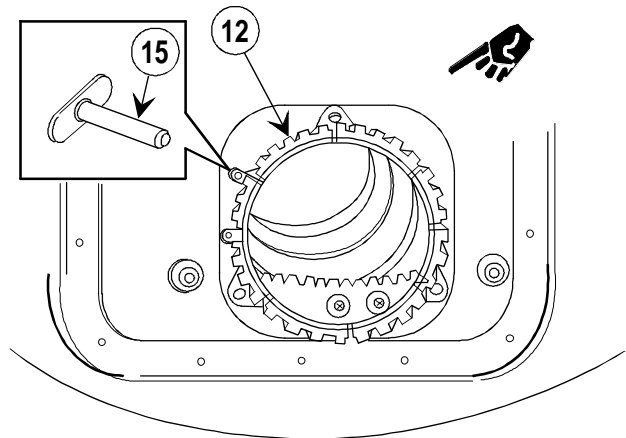
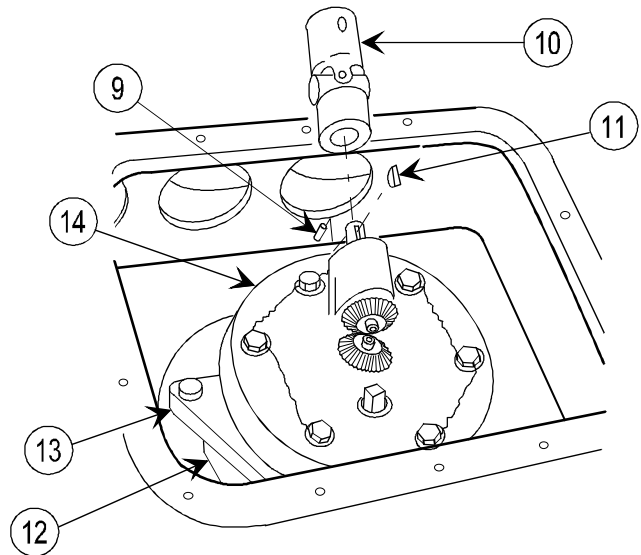

DISASSEMBLY

- 1 Remove two pipe plugs (1) and drain oil (hydraulic fluid) from traversing angle drive unit (2).

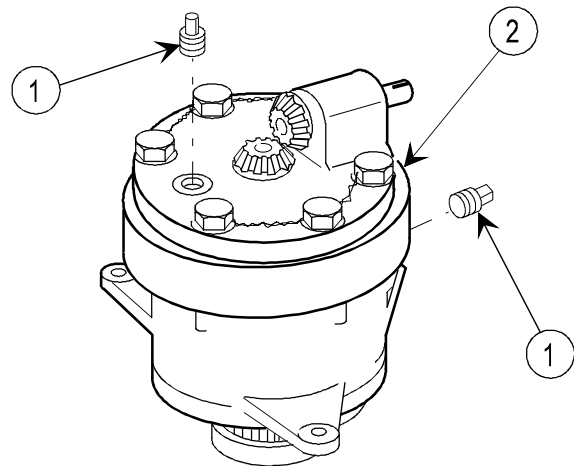

2-35. TRAVERSING ANGLE DRIVE UNIT—MAINTENANCE INSTRUCTIONS (cont)

DISASSEMBLY (cont)

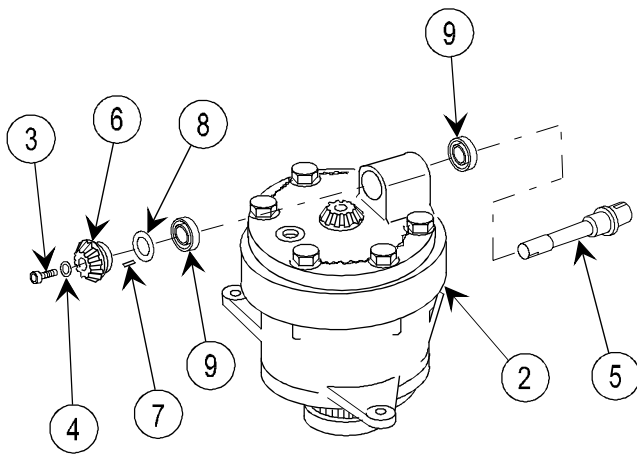

- 2 Remove bolt (3) and flat washer (4).
- 3 Drive out shouldered shaft (5).
- 4 Remove bevel gear (6), machine key (7), and shim (8).
- 5 Remove two annular ball bearings (9) from traversing angle drive unit (2).

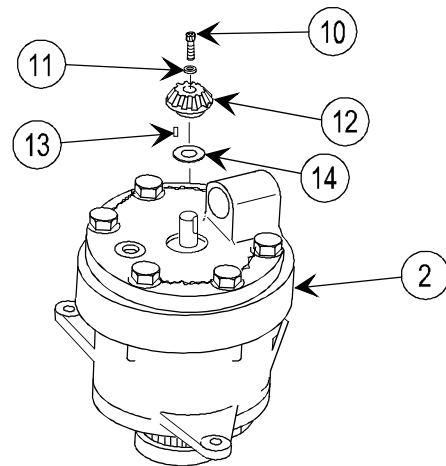

- 6 Remove bolt (10) and flat washer (11).
- 7 Remove bevel gear (12) and machine key (13).
- 8 Remove shim (14) from traversing angle drive unit (2).

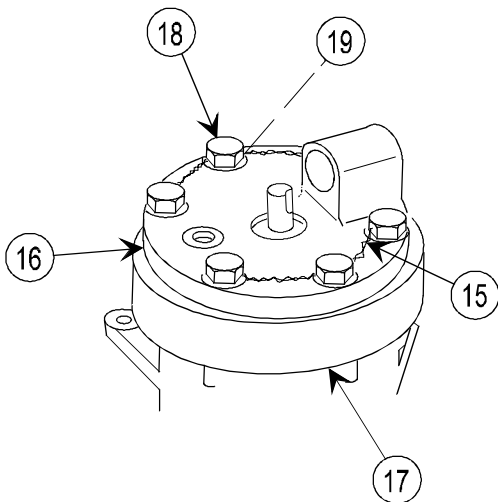

- 9 Remove lock wire (15).

NOTE

Scribe line across cover (16) and housing (17).

- 10 Remove six capscrews (18) and six washers (19).

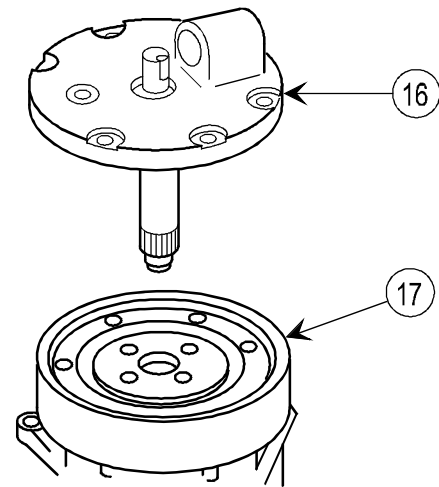

- 11 Remove cover (16) and attached parts from housing (17).

- 12 Remove shouldered shaft (20) with shim (21) and annular ball bearing (22) attached from cover (16). If necessary for repair or replacement, remove annular ball bearing (22) and shim (21) from shouldered shaft (20).
- 13 Remove bearing seat (23), retainer and rollers (24), bearing seat (25), and roller bearing (26) from housing (17).

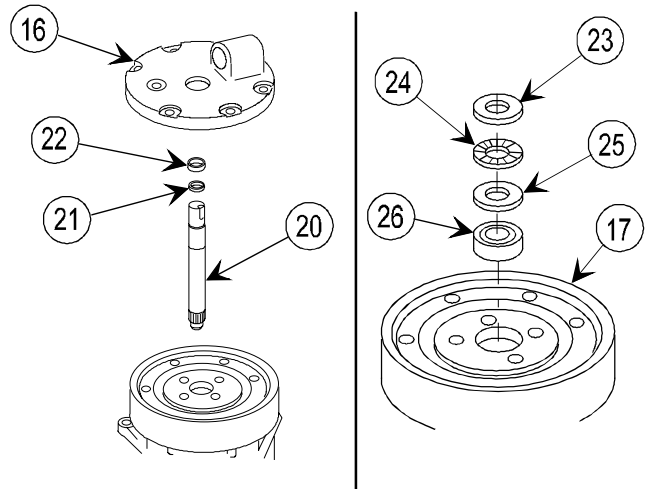

CAUTION

Do not disassemble flexispline as damage to equipment may result.

- 14 Scribe lines on circular spline (27), flexispline (28), and housing (17).

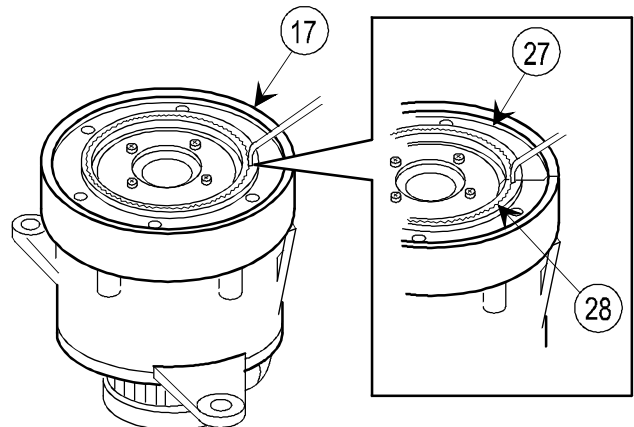

- 15 Invert housing with circular spline and flexispline intact and place on block so outer edge of housing rests on blocks.
- 16 Using a rubber mallet, tap on gear in center of bearing (29) until circular spline (27) and flexispline (28) drop free of housing (17).

NOTE

If circular spline (27) stays in housing (17), loosen by tapping evenly around circular spline (27) with a rubber mallet, and then pull circular spline (27) out of housing (17).

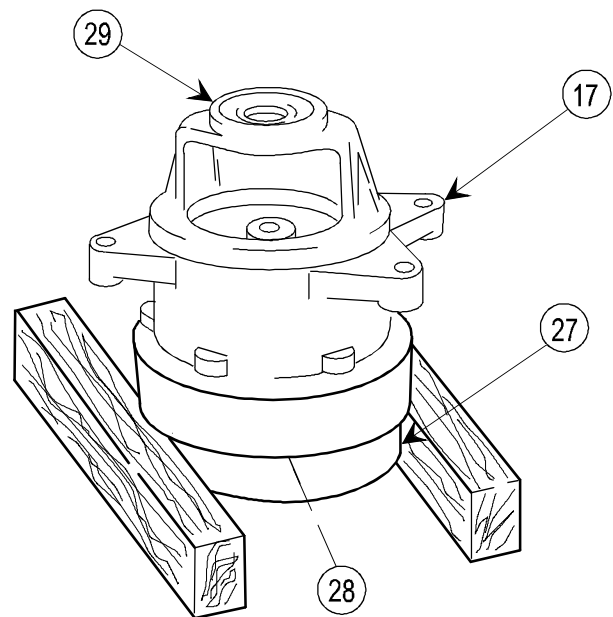

2-35. TRAVERSING ANGLE DRIVE UNIT—MAINTENANCE INSTRUCTIONS (cont)

DISASSEMBLY (cont)

- 17 Remove housing (17).
- 18 Remove ball bearing (29) from housing.

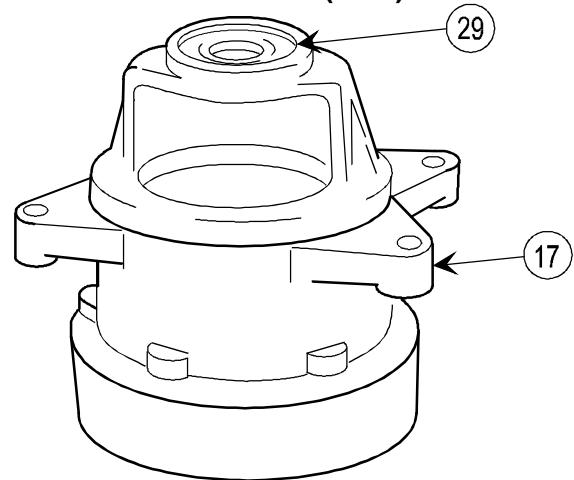

INSPECTION/REPAIR

- 1 Check for broken, damaged, or missing parts.
- 2 Repair is by replacement of authorized parts (TM 9-1025-211-34P).

REASSEMBLY

- 1 Install ball bearing (1) in housing (2).

NOTE

Before installing housing, ensure scribe marks on circular spline (3) and flexispline (4) line up.

- 2 Lower housing (2) onto flexispline (4) and circular spline (3).

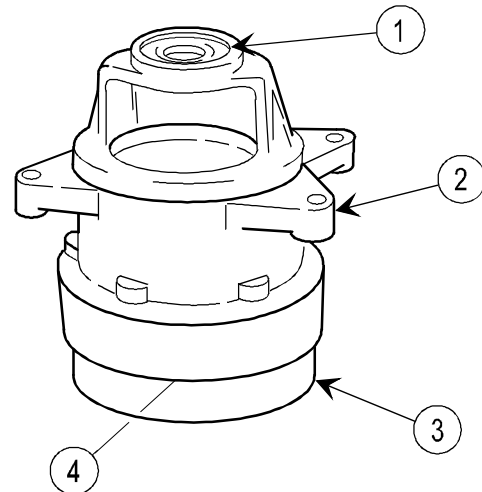

- 3 Return housing (2) with circular spline (3) and flexispline (4) installed to an upright position.
- 4 Ensure scribe lines on circular spline (3) and flexispline (4) line up; if not, remove housing (2) and align scribe lines.
- 5 Turn circular spline (3) until bolt holes in housing (2) and circular spline (3) line up.

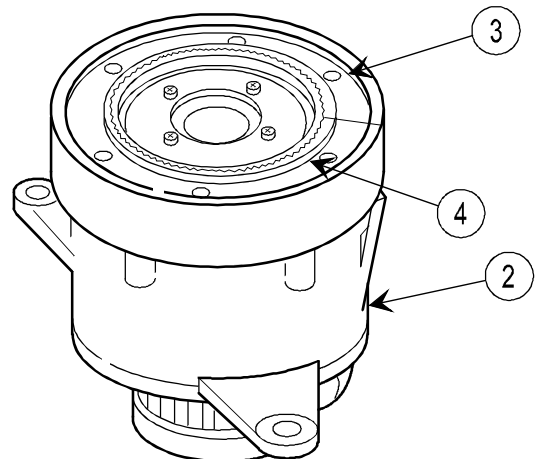

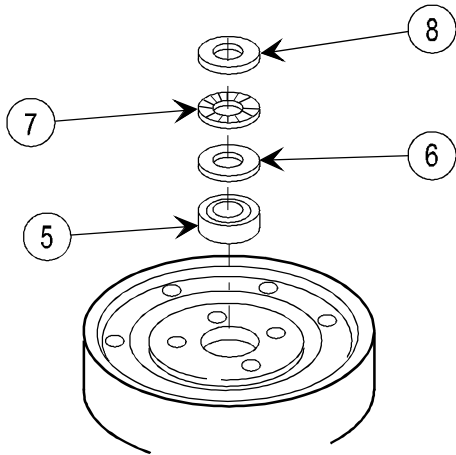

6 Install roller bearing (5), bearing seat (6), retainer and rollers (7), and bearing seat (8).

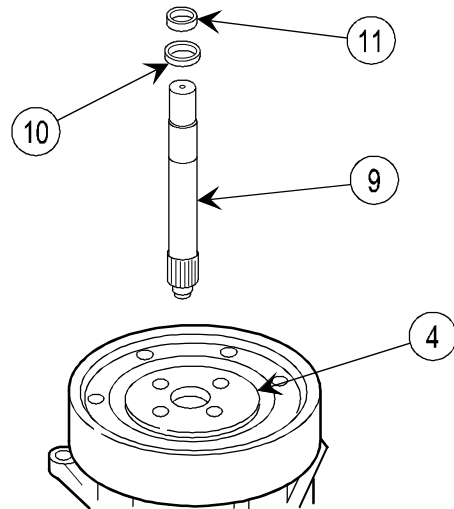

7 Install shouldered shaft (9) into flexispline (4).

8 If removed, install shim (10) and annular ball bearing (11) to shouldered shaft (9).

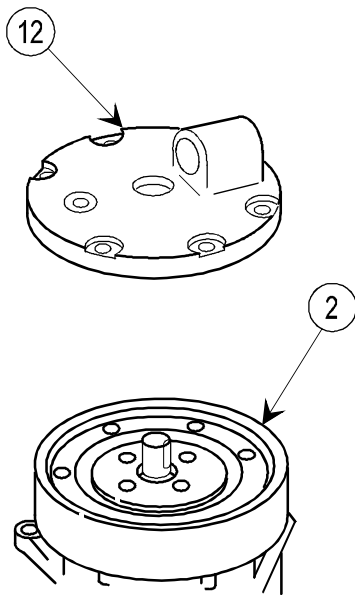

9 Aline scribe lines and install cover (12) on housing (2).

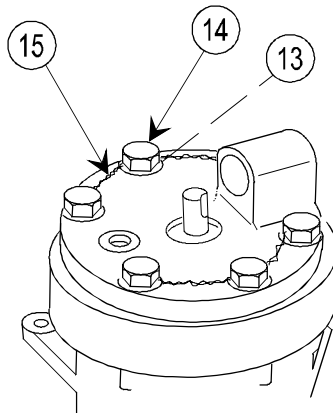

10 Install six washers (13) and six cap screws (14); torque cap screws to 40.0 ±5.0 ft-lb (54.2 ±6.8 N-m).

11 Install lock wire (15) (item 34, appx B).

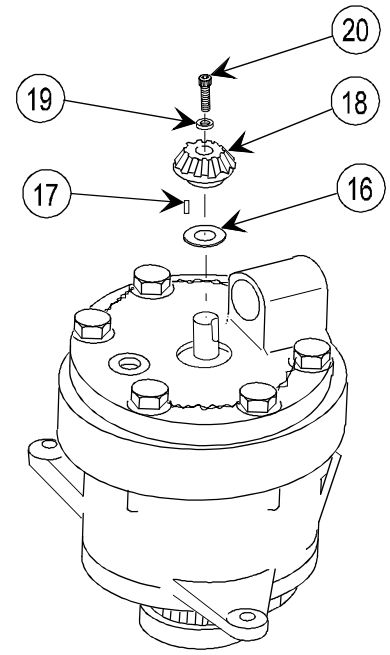

12 Install shim (16).

13 Install machine key (17) and bevel gear (18).

14 Install flat washer (19) and bolt (20); torque to 24.0 to 29.0 in.-lb (2.7 to 3.3 N-m).

2-35. TRAVERSING ANGLE DRIVE UNIT—MAINTENANCE INSTRUCTIONS (cont)

REASSEMBLY (cont)

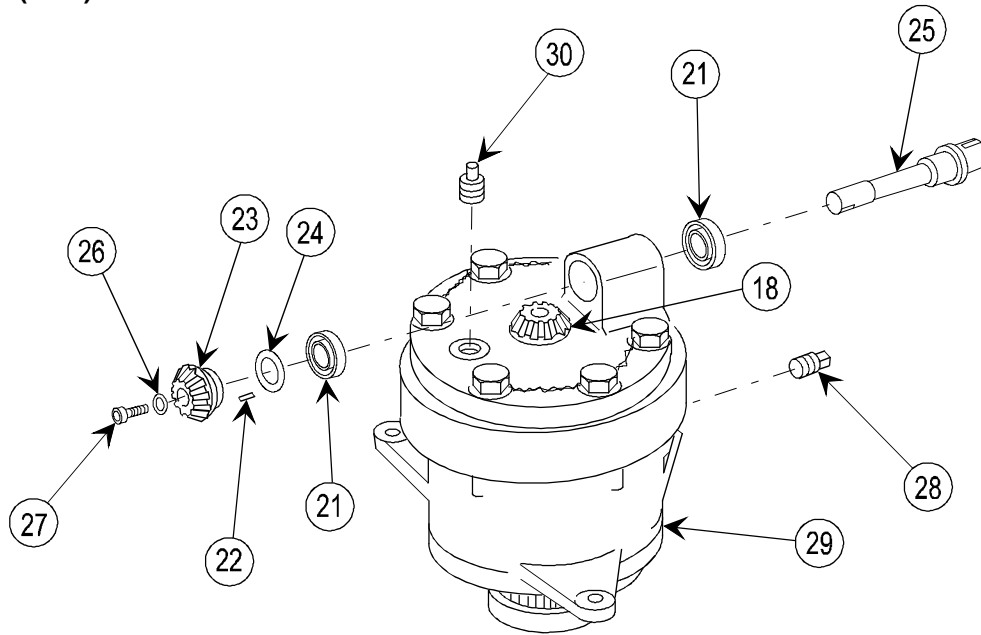

- 15 Install two annular ball bearings (21).
- 16 Place machine key (22), bevel gear (23), and shim (24) in position.
- 17 Drive shouldered shaft (25) back into position through annular ball bearings (21), shim (24), and bevel gear (23).

NOTE

Use dial indicator to check for backlash of 0.003 to 0.005 in. (0.008 to 0.013 cm) between bevel gears. Disassemble and adjust shims as required until proper backlash is obtained.

- 18 Install flat washer (26) and bolt (27) and torque 24.0 to 29.0 in.-lb (2.7 to 3.7 N-m).
- 19 Apply WTR grease to bevel gears (23 and 18).
- 20 Install one pipe plug (28) on side of housing. Slowly pour 1 pint (1/2 liter) of oil (hydraulic fluid) into traversing angle drive unit (29); install other pipe plug (30) on cover.

INSTALLATION

- 1 Install adjusting ring (1) and key (2).
- 2 Aline adjusting ring (1) with scribe mark.

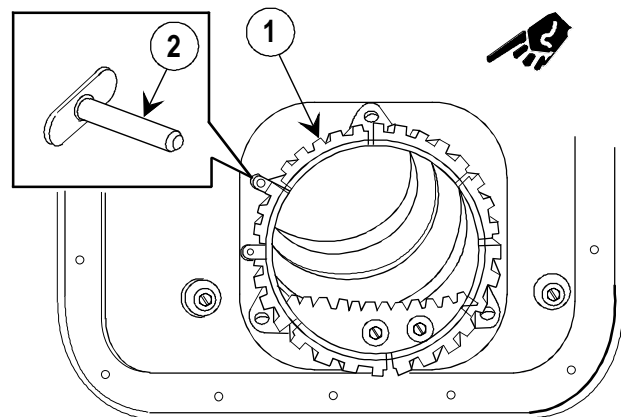

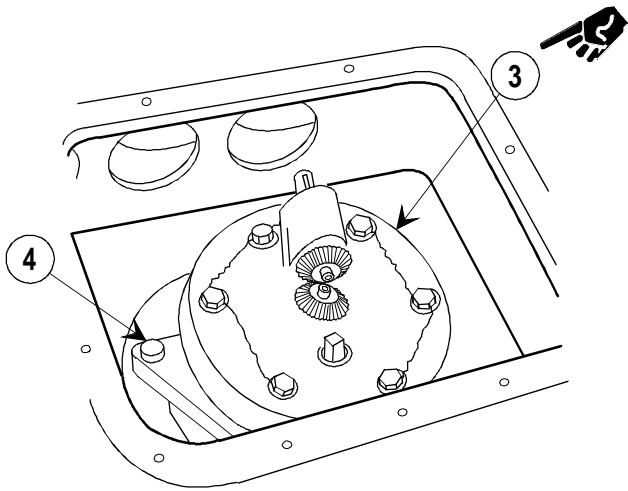

- 3 Install traversing angle drive unit (3) with pin (4) aligned with mating holes.

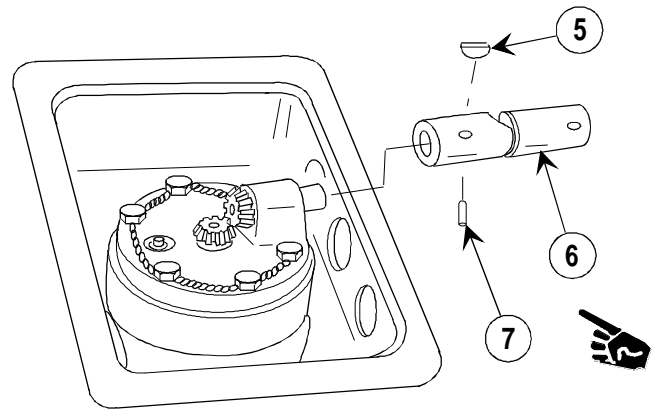

- 4 Install key (5), universal joint (6), and spring pin (7).

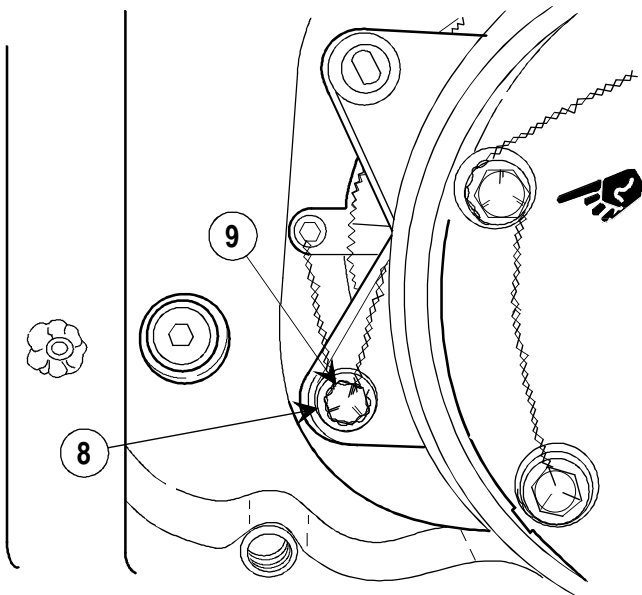

- 5 Install three washers (8) and three screws (9); do not tighten.

NOTE

Prior to checking backlash or performing adjustment procedures, assemblies removed as equipment conditions must be installed.

- 6 Check traversing handwheel (10) for backlash of 1/12 turn (3-1/8 in. (7.9 cm)) or less. If excessive backlash exists, perform adjustment (p 2-240).

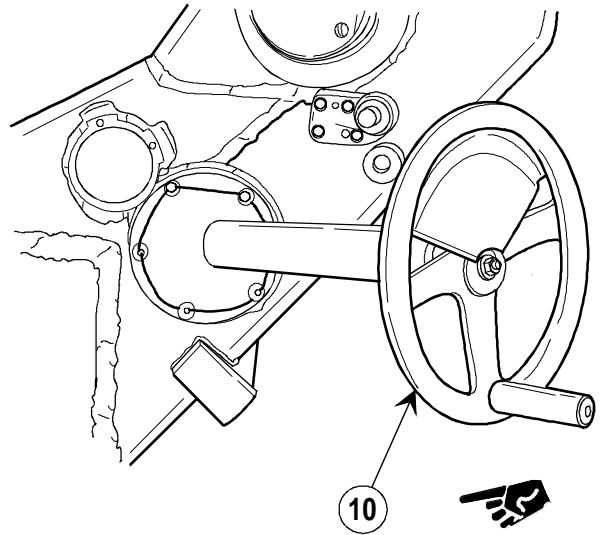

2-35. TRAVERSING ANGLE DRIVE UNIT—MAINTENANCE INSTRUCTIONS (cont)

INSTALLATION (cont)

- 7 Install stop (11).
- 8 Install washer (12) and capscrew (13).
- 9 Torque three screws (9) to 65.0 to 85 ft-lb (88 to 115 N-m) and install lockwire (14) (item 35, appx B).
- 10 Install lock wire (item 34, appx B) (15) between screw (9) and capscrew (13).

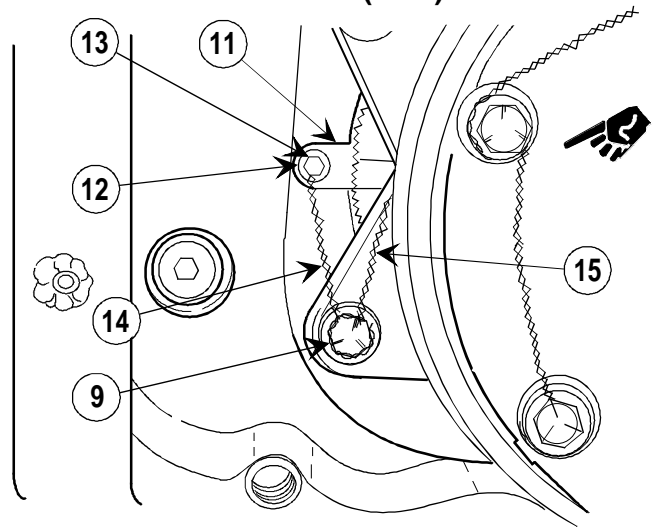

ADJUSTMENT

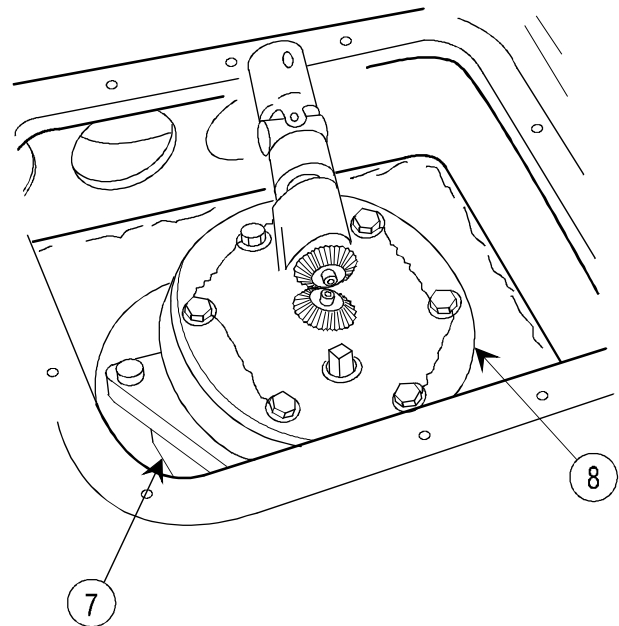
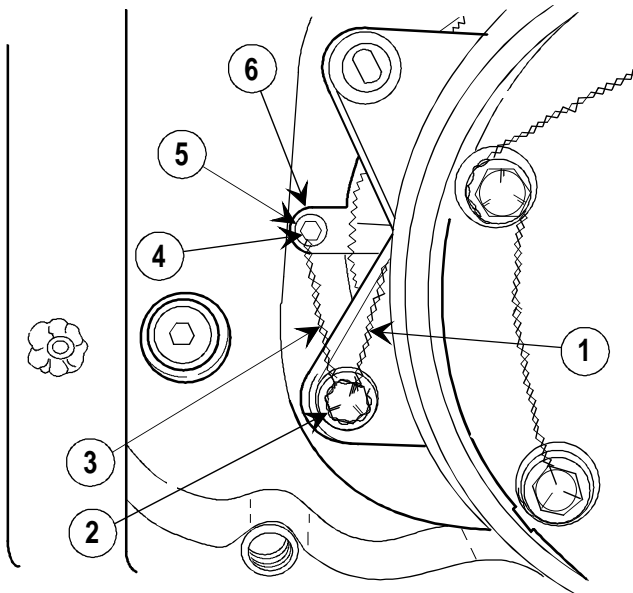

- 1 Remove lock wire (1).
- 2 Loosen three screws (2).
- 3 Remove lock wire (3), capscrew (4), and washer (5).
- 4 Remove stop (6).

- 5 Rotate adjusting ring (7) clockwise as viewed from top until backlash is eliminated between output spur gear and internal gear inside carriage. Reverse rotation three teeth.

NOTE

If backlash cannot be eliminated or traversing mechanism binds, perform steps 6 thru 9.

- 6 Center adjusting ring (7) and traversing angle drive unit (8) by traversing top carriage seven degrees (133 mils) to the left and right.
- 7 Install stop (6), washer (5), and capscrew (4).
- 8 Tighten three screws (2).
- 9 Traverse top carriage to left and right, checking for equal handwheel pressure. If uneven (hard) traverse condition to either left or right exists, perform the following steps. Then traverse to left and right, checking for clearance of shim (p 2-232).
- 10 Perform service (p 2-241).
- 11 Check torque limiter for proper torque adjustment (p 2-232).
- 12 Torque three screws (2) to 65 to 85 ft-lb (88 to 115 N-m) and install lock wire (item 35, appx B) (3).
- 13 Install lock wire (item 34, appx B) (1) between screw (2) and capscrew (4).

SERVICE

NOTE

Perform service at intervals as indicated in appendix E.

- 1 Remove pipe plug (1).
- 2 Add 1/2-pint (1/4 liter) oil (hydraulic fluid).
- 3 Install pipe plug (1).

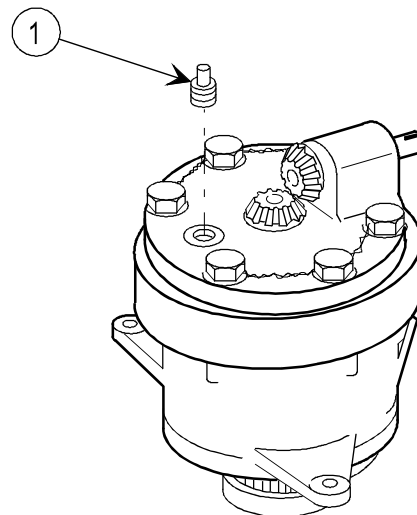

2-36. TOP CARRIAGE ASSEMBLY—MAINTENANCE INSTRUCTIONS

THIS TASK COVERS:

- | | | |
|---------------|-----------------|----------------------|
| a. Removal | b. Disassembly | c. Inspection/repair |
| d. Reassembly | e. Installation | |

INITIAL SETUP

Tools and Special Tools

Artillery and turret mechanic's ordnance tool kit (SC 5180-95-CL-A12)
Artillery field maintenance shop equipment (SC 4933-95-CL-A12)
M198 repairman field artillery tool kit (5911278)
Safety strut assembly (12008900)
3-ton hoist available

Materials/Parts

Cotter pin (2) (MS24665-495)
Gasket (2) (12008273)
Primer (item 20, appx B)
Sealing compound (item 28.1, appx B)
WTR grease (item 11, appx B)

Personnel required: 2

Artillery repairmen to lift internal gear

References

TM 9-1025-211-10
TM 9-1025-211-20&P
TM 9-1025-211-34P

Equipment Conditions

NOTE

The following conditions apply to the removal of top carriage assembly.

- 2-23 M199 cannon removed
- 2-58 M45 recoil mechanism removed
- 2-150 Equilibrators bled to 250 psi (1723 kPa) and travel lock disengaged
- 2-232 Traversing angle drive unit removed
- 2-222 Traversing drive unit removed

NOTE

The following conditions apply to disassembly of equilibrator adjustment screws.

- Travel lock assembly engaged in bottom carriage (TM 9-1025-211-10)
- 2-151 Equilibrator pressure bled to zero psi and disconnected from adjustment screw bracket

General Safety Instructions

WARNING

All lifting devices must be checked in accordance with local Standing Operating Procedure (SOP) to make sure they are in good working condition before starting the lifting operation.

REMOVAL

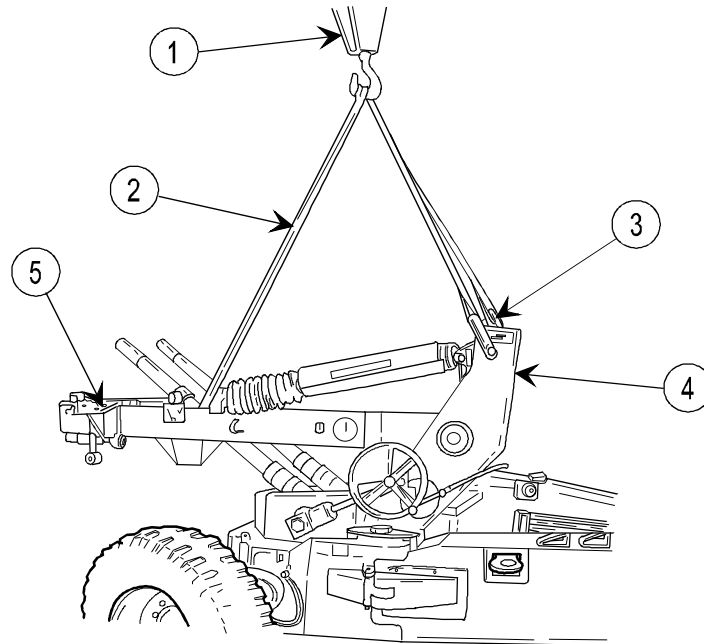

NOTE

Use care to ensure 3-ton hoist (1) is at the center of balance to prevent damage to the seal on the bottom carriage assembly.

- 1 Attach sling (2) and 3-ton hoist (1) to hoisting link (3) of top carriage assembly (4) and to cradle assembly (5).

NOTE

Top carriage assembly is not replaceable, but may be removed to gain access to internal gear.

NOTE

Three capscrews may be removed at one time, and then the top carriage assembly must be rotated to reach three more capscrews. Place trails close enough together so the stops on the front of the trails will not interfere with rotation of the top carriage assembly.

- 2 Remove 64 capscrews (6). Retain capscrews for installation.

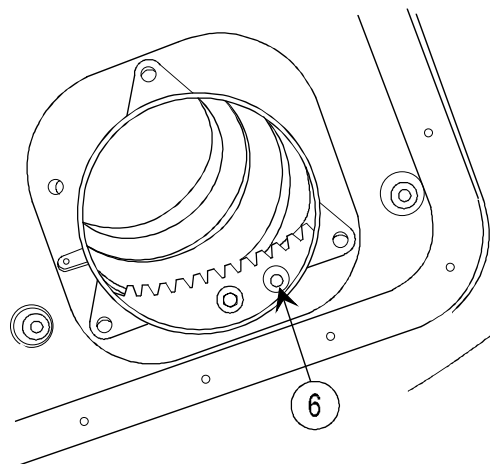

2-36. TOP CARRIAGE ASSEMBLY—MAINTENANCE INSTRUCTIONS (cont)

REMOVAL (cont)

- 3 Lift top carriage assembly (4) with sling (2) and 3-ton hoist (1), and remove.
- 4 Place top carriage assembly on suitable supports to prevent damage to internal gear (7).

CAUTION

Remove grease fitting and extension tube from top carriage assembly (4) before attempting to separate top carriage (4) from internal gear (7). The extension tube is threaded into the internal gear and will be broken off if not removed.

- 5 Remove grease fitting (8) from extension tube (9) and top carriage assembly (4).
- 6 Remove extension tube (9) from internal gear (7) and top carriage assembly (4).

WARNING

Leave 3-ton hoist attached to top carriage while removing bolts in internal ring gear.

NOTE

There are two different size bolts in the outer ring. The larger bolts are removed to accomplish removal of the internal gear from the top carriage assembly.

- 7 With blocks (10) under top carriage assembly (4), remove 48 large bolts (11) that are showing.
- 8 Raise top carriage assembly (4) enough to rotate position on blocks (10) to reach the remaining bolts; then lower back onto blocks.

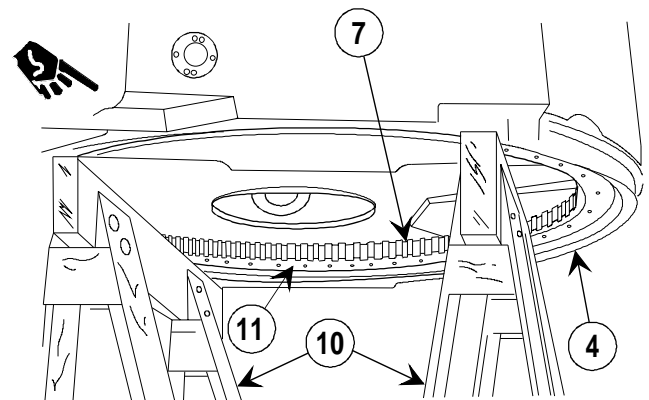
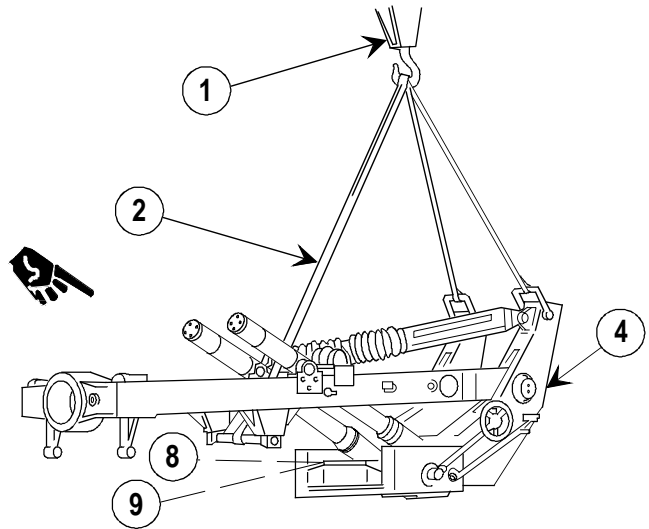

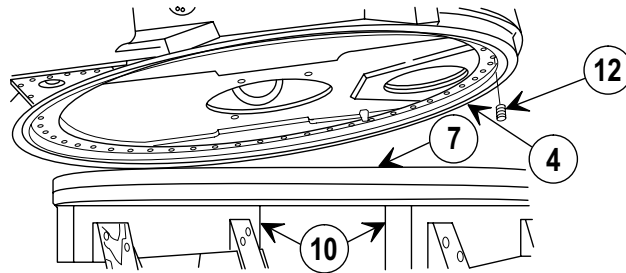

- 9 Raise top carriage assembly (4) off of internal gear (7).
- 10 Remove internal gear (7) from blocks (10).
- 11 Place top carriage assembly (4) on blocks (10).
- 12 To inspect internal (ring) gear (7), follow procedures in Note 1 of Appendix E, Bi-Yearly.

CAUTION

Removing threaded inserts may cause damage. Do not remove them unless necessary for replacement of authorized parts.

- 13 Remove 48 threaded inserts (12).

DISASSEMBLY

NOTE

Procedures are given for only one side, but may be followed for both sides. Top carriage assembly need not be removed for following procedures.

Two elevation bearing caps (1) are not replaceable parts (TM 9-1025-211-34P), but must be removed for maintenance of top carriage assembly. Use care to ensure these parts are not lost or damaged during disassembly.

Do not remove two lubrication fittings (2) from elevation bearing caps (1).

- 1 Remove four bolts (3), four lockwashers (4), two retaining straps (5), and two elevation bearing caps (1) with two lubrication fittings (2) from top carriage assembly (6).
- 2 Remove four sleeve bushings (7) from each set of elevation bearing caps (1).

CAUTION

Removing threaded inserts may cause damage. Do not remove them unless necessary for replacement of authorized parts.

- 3 Remove four threaded inserts (8).
- 4 Remove 28 capscrews (9) and 28 washers (10).

NOTE

Second gasket (11) and standoff covers (12) are on modified howitzers only.

- 5 Remove two access covers (13) and four gaskets (11). Remove two standoff covers (12).
- 6 Remove 28 inserts (14).

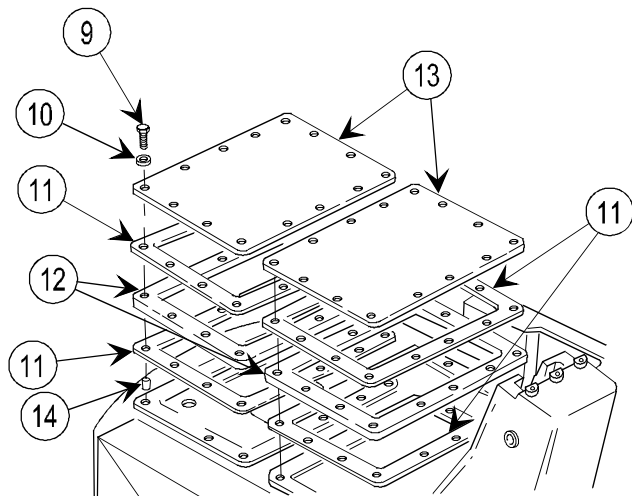
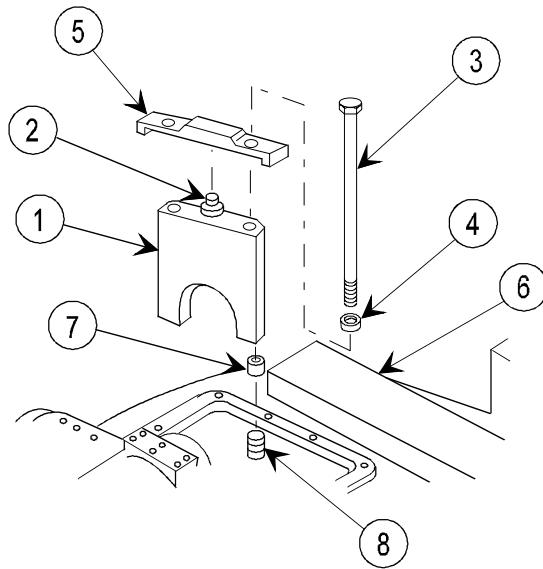

2-36. TOP CARRIAGE ASSEMBLY—MAINTENANCE INSTRUCTIONS (cont)

DISASSEMBLY (cont)

WARNING

Equilibrator nitrogen pressure must be bled to 0 (zero) psi and equilibrator cylinders must be removed (TM 9-1025-211-20&P) for steps 7 thru 11. Failure to bleed the nitrogen pressure could cause the equilibrator to pull up with extreme force and injure personnel or damage equipment.

NOTE

Procedures 7 thru 15 pertain to howitzers that have not been modified.

CAUTION

Removing threaded inserts (15) may cause damage. Do not remove unless necessary.

7 Remove four capscrews (16), two hex head bolts (17), two lockwashers (18), bracket (cover) (19), spacer (20), shim (21), and two threaded inserts (15).

8 Remove shoulder screw (22) and bracket (23) together, then remove shoulder screw (22) from bracket (23).

NOTE

Scribe a line on each slide liner, if removed, to facilitate the correct installation of slide liners.

9 If necessary, remove two slide liners (24) from bracket (23) by removing six solid rivets (25).

10 Remove plate spacer (26) from counterbored hole in base of top carriage.

11 Remove eight self-locking bolts (27) and two slide assembly guides (28).

12 Remove two screws (29) and plate (30) from top carriage.

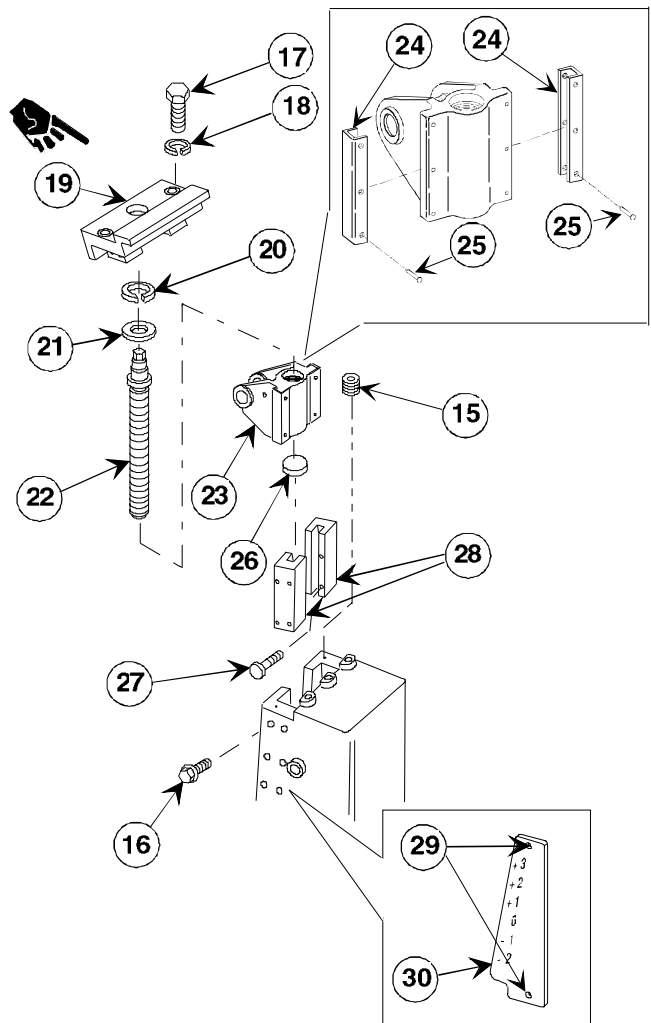

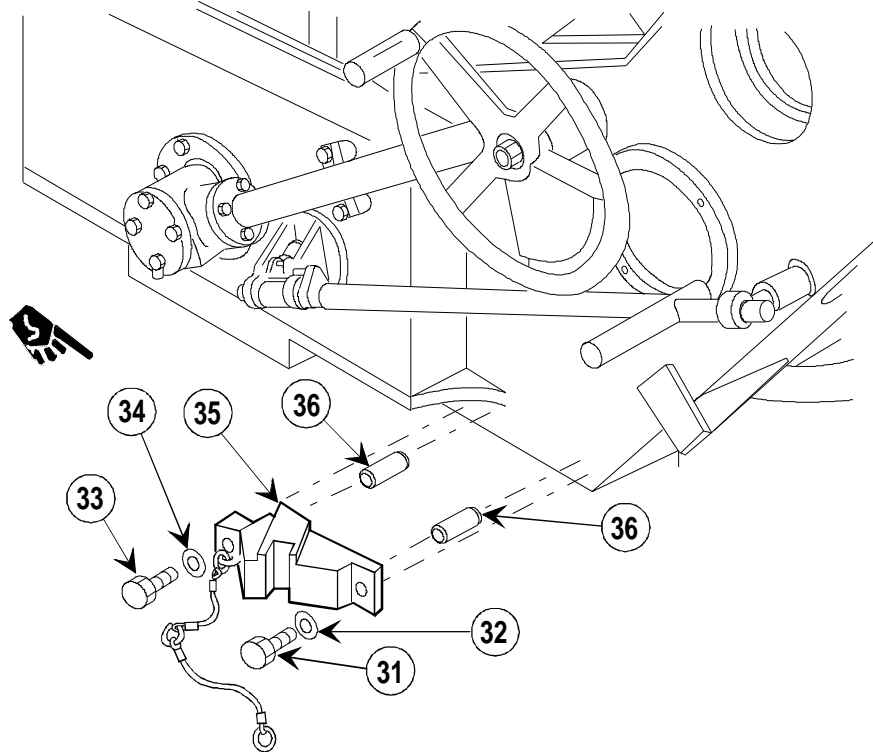

- 13 Remove capscrew (31) and lockwasher (32).
- 14 Remove capscrew (33) and lockwasher (34).
- 15 Remove bracket (35) with attached parts.

NOTE

Steps 16 and 17 apply to both modified and unmodified howitzers.

- 16 Remove two pins (36).

CAUTION

Removing threaded inserts may cause damage. Do not remove them unless necessary for replacement of authorized parts.

- 17 Remove two threaded inserts (37).

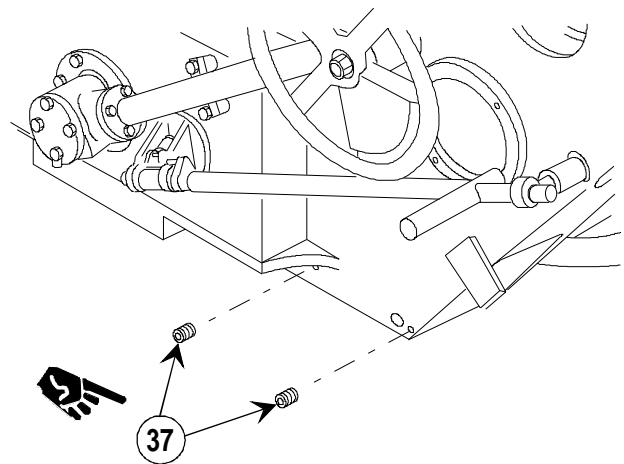

2-36. TOP CARRIAGE ASSEMBLY—MAINTENANCE INSTRUCTIONS (cont)

DISASSEMBLY (cont)

WARNING

Equilibrator nitrogen pressure must be bled to 0 (zero) psi and equilibrator cylinders must be removed (TM 9-1025-211-20&P) for steps 18 thru 23. Failure to bleed the nitrogen pressure could cause the equilibrator to pull up with extreme force and injure personnel or damage equipment.

CAUTION

Removing threaded inserts may cause damage. Do not remove them unless necessary for replacement of authorized parts.

NOTE

Steps 18 thru 24 apply to modified howitzers.

- 18 Remove four capscrews (38), two hex head bolts (39), two lockwashers (40), bracket (cover) (41), and two inserts (42).

NOTE

There may be one or more races depending on clearance between bearing and counter bore on bracket.

- 19 Remove shim (43), races (44), and bearing (45) from shoulder bolt (46).
- 20 Remove shoulder bolt (46) and bracket (47) together. Remove shoulder bolt (46) from bracket (47).

NOTE

Scribe a line on each slide liner, if removed, to facilitate the correct installation of slide liners.

- 21 If necessary, remove two slide liners (48) from bracket (47) by removing six solid rivets (49).
- 22 Remove plate spacer (50) from counterbored hole in base of top carriage.
- 23 Remove eight self-locking bolts (51) and two slide assembly guides (52) from top carriage.

NOTE

Screws (53) and plate (54) are located on the inside of top carriage uprights on modified howitzers.

- 24 Remove two screws (53) and designation plate (54) from inside of top carriage.

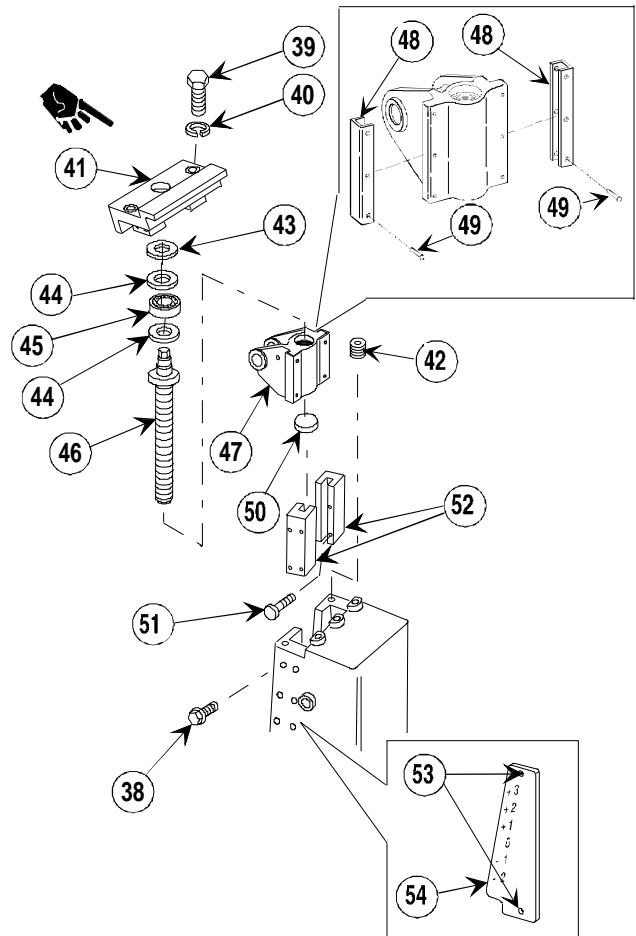

NOTE

Steps 25 thru 27 apply to both modified and unmodified howitzers.

- 25 Remove four screws (55) and instruction plate (56).

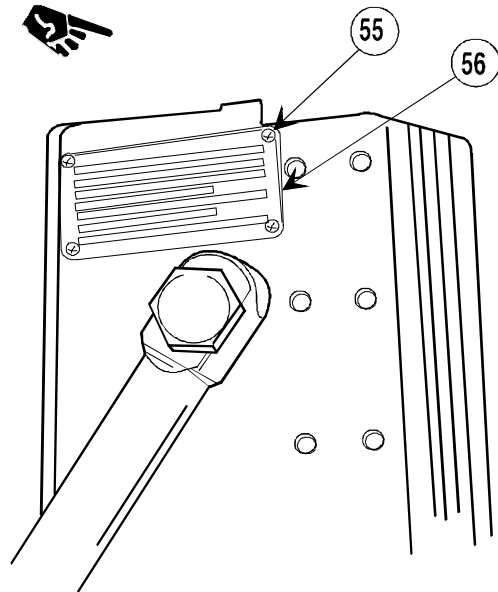

- 26 Remove 13 capscrews (57) and capscrew (58) from top carriage.

- 27 Remove access cover (59) and shim (60).

NOTE

Steps 28 thru 30 apply to modified howitzers.

- 28 Remove screw (61) and washer (62).
- 29 Remove screw (63) and washer (64).
- 30 Remove lock assembly (65) and shim (66).

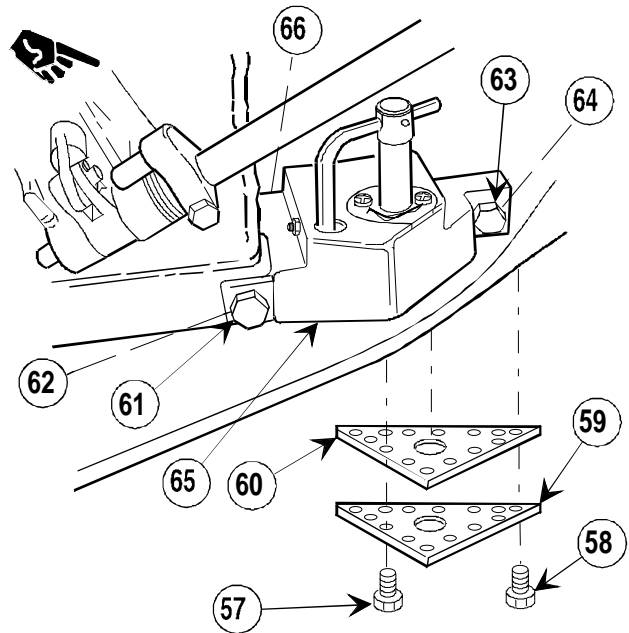

2-36. TOP CARRIAGE ASSEMBLY—MAINTENANCE INSTRUCTIONS (cont)

INSPECTION/REPAIR

- 1 Check for broken, damaged, or missing parts.
- 2 Repair is by replacement of authorized parts (TM 9-1025-211-34P).
- 3 Lubricate parts per TM 9-1025-211-10, F.

REASSEMBLY

NOTE

Steps 1 and 2 apply to both modified and unmodified howitzers.

Steps 3 thru 11 apply to howitzers that have not been modified.

Procedures are written for one adjustment screw assembly, but apply to both.

- 1 Coat two threaded inserts (1) and mating holes with primer (item 20, appx B); install while primer is wet.
- 2 Install two pins (2).
- 3 Install bracket (3) with attached parts.
- 4 Install lockwasher (4) and capscrew (5).
- 5 Install lockwasher (6) and capscrew (7).
- 6 Install plate (8) and two screws (9).

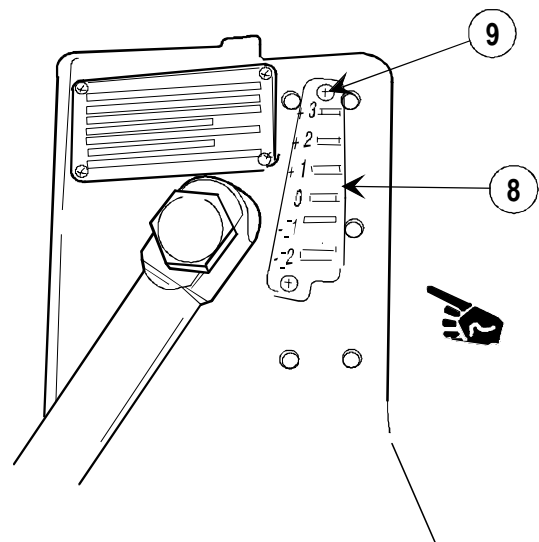
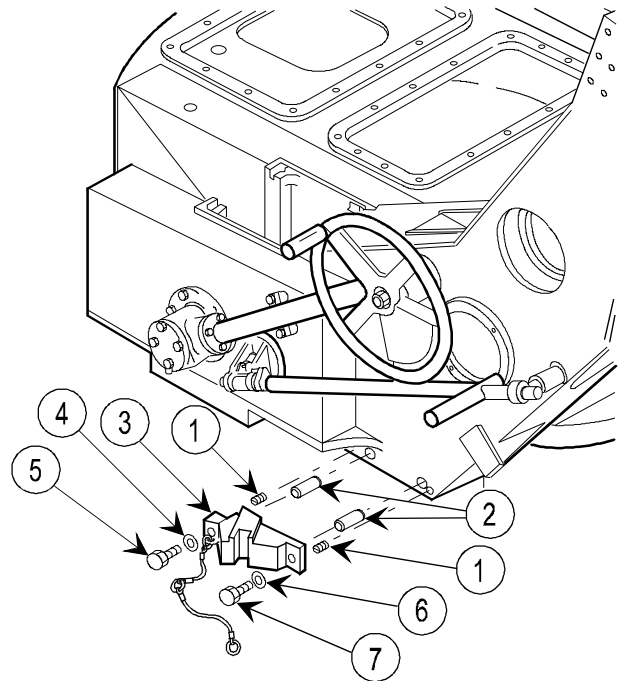

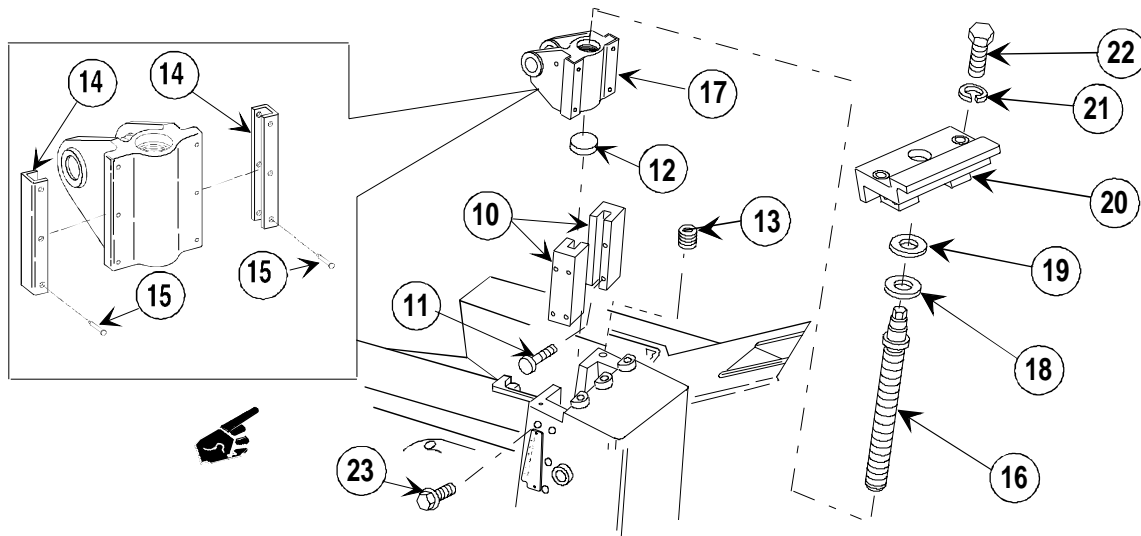

- 7 Install two slide assembly guides (10) and eight capscrews (11). Apply WTR grease to adjustment screw slide area of the guides.
- 8 Install plate spacer (12).
- 9 If removed, coat two threaded inserts (13) and mating holes in top carriage with primer (item 20, appx B); install while primer is wet.

NOTE

Use caution when hand filling or grinding rivets to blend in with slide liners.

- 10 If removed, install two slide liners (14).
- 11 If removed, install six solid rivets (15).
- 12 Grind or file rivets (15) flush with liners (14).
- 13 Apply WTR grease to shoulder screw (16) and bracket (17), assemble, and install in slide assembly guides (10).

NOTE

Shim must be adjusted to provide 0.005 in. (0.013 cm) clearance between access cover and mating surface on shoulder screw.

- 14 Install shim (18), spacer (19), and bracket (20) to provide the 0.005 in. (0.013 cm) clearance between shoulder screw (16) and bracket (20).

CAUTION

Do not overtighten the capscrews. If capscrews are tightened too tight, the counterbored shoulder of the top carriage could be damaged.

Do not overtighten hex head bolts. Torque to 40 ft-lb (54.6 N-m).

- 15 Install two lockwasher (21) and two hex head bolts (22), and torque to 40 ft-lb (275.8 N-m). Install four capscrews (23) and tighten until contact is made with the counterbored surface of the top .

2-36. TOP CARRIAGE ASSEMBLY—MAINTENANCE INSTRUCTIONS (cont)

REASSEMBLY (cont)

- 16** Set the equilibrator adjustment screw pointer to "0" and charge equilibrators to 1750 psi at ambient temperature (TM 9-1025-211-20&P), service by charging with nitrogen procedures. Deviation of the procedure is necessary in step 15; the nitrogen pressure should be brought up to approximately 1800 psi and allowed to stabilize prior to regulating the pressure to 1750 psi.

NOTE

If neither the shim (24) nor the lock assembly (25) was replaced, perform steps 17 thru 19. If either part was replaced, perform steps 20 thru 37 to ensure proper alinement of the lock assembly.

- 17** Install shim (24) and lock assembly (25); install washer (26) and screw (27). Do not tighten screw.
- 18** Install washer (28) and screw (29). Do not tighten screw.
- 19** Tighten screws (27 and 29) until the lock assembly is tight against the shim and top carriage. Slightly loosen both screws, and then torque each screw, (29) first, to 80 ft-lb (108 N-m).

NOTE

The exact location of lock assembly (25) over bottom carriage pin hole must be determined prior to completion of this task. Once this is determined, a laminated shim (24) will be adjusted to the thickness required and installed between the top carriage and the lock assembly.

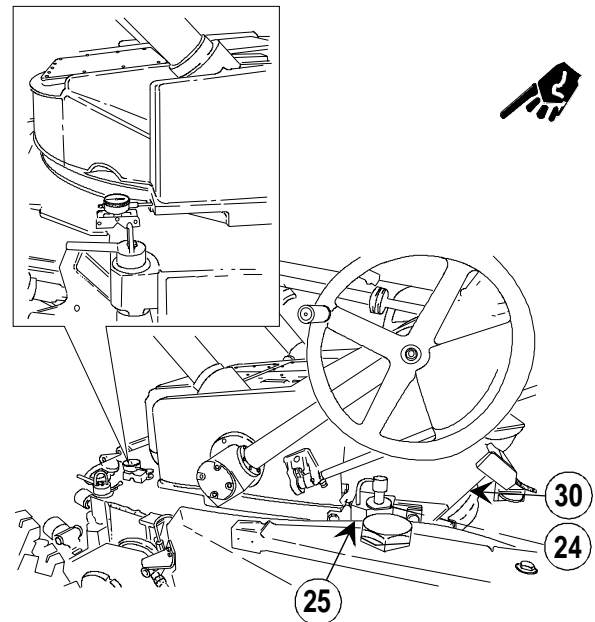
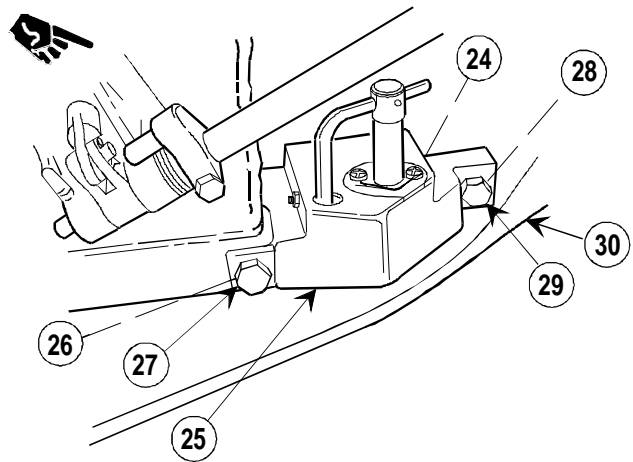

- 20 Lower travel lock assembly and lock it to the bottom carriage.
- 21 Secure 1 in. travel indicator with magnetic base to the bottom carriage with the indicator touching the left front corner of the top carriage. Zero the travel .
- 22 Slowly turn the traversing drive handwheel clockwise until resistance is felt. Record the movement of the pointer on the dial.
- 23 Slowly turn the traversing drive handwheel counterclockwise until resistance is felt. Record the movement of the pointer on the dial.
- 24 Add the movement from zero in steps 22 and 23, and divide by two.
- 25 Traverse the howitzer clockwise until the dial indicator movement corresponds to the quotient of step 24. Rezero the dial
- 26 With the travel indicator set to zero and the travel lock disengaged, traverse the top carriage (30) counterclockwise until the lock assembly mounting surface is clear of the bottom carriage.
- 27 Install lock assembly (25), two washers (26 and 28), and two screws (27 and 29). Tighten screws (27 and 29) until there is approximately 1/16 in. (0.159 cm) clearance between the lock assembly (25) and the top carriage (30).
- 28 Traverse the top carriage (30) clockwise until the travel indicator reads zero. Rotate the lock handle to its locked position. If the pin drops into the bottom carriage, measure the distance between the top carriage (30) and the lock assembly (25) using feeler gage stock.
- 29 If the pin does not drop into the bottom carriage, tighten or loosen screws (27 and 29) equally until it does. Measure the distance between the top carriage (30) and lock assembly (25).
- 30 Raise the lock pin and swing the handwheel to the full unlocked position. Traverse the top carriage counterclockwise until it clears the bottom carriage.

2-36. TOP CARRIAGE ASSEMBLY—MAINTENANCE INSTRUCTIONS (cont)

REASSEMBLY (cont)

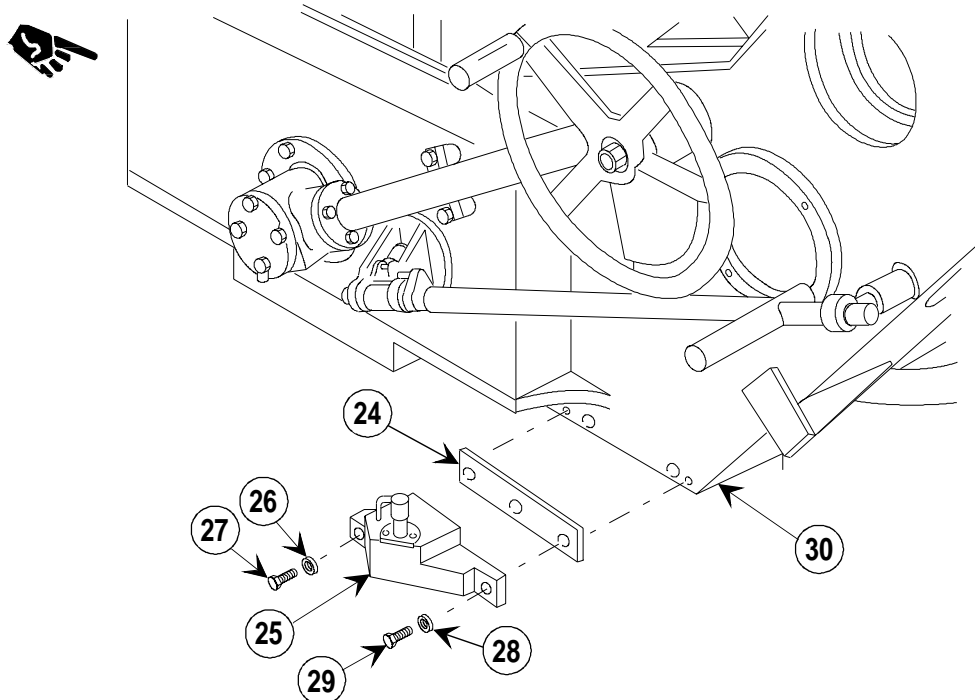

- 31 Remove two screws (27 and 29), two washers (26 and 28), and lock assembly (25). Use shim requirements of either step 28 or 29 and add approximately 0.006 in. (0.015 cm) to thickness.

NOTE

It may be necessary to drive the two pins into the top carriage (30) to ensure there is proper mating of the lock assembly (25) to the top carriage (30).

- 32 Drive pins into top carriage using a brass drift and hammer.
- 33 Adjust the thickness of the shim stock (24) and install it between the lock assembly (25) and the top carriage (30).
- 34 Install two washers (26 and 28) and two screws (27 and 29) and tighten until the lock assembly (25) is tight against the shims (24) and top carriage (30). Loosen both screws and apply 80 ft-lb (551.6 N-m) of torque, first to right screw and then to left screw.
- 35 Turn the travel lock pin to the automatic lock position. Traverse the top carriage clockwise until the lock pin engages with the bottom carriage hole. If pin does not drop into the bottom carriage hole, traverse the top carriage until the travel indicator reads zero. Remove the two screws in the collar that secure the pin and spring to the lock assembly. Physically check the alignment of the lock assembly hole with the hole in the bottom carriage.
- 36 Repeat steps 26 thru 35 until traverse lock pin drops into the bottom carriage pin hole.
- 37 Lower the travel lock assembly and lock it to the bottom carriage, making sure it fits freely with no binding. If travel lock does not fit freely, further adjustment of traverse lock shims may be necessary.

NOTE

Shim (31) must be adjusted to provide 0.005- to 0.015-in.(0.130- to 0.380-mm) clearance between access cover (32) and bottom carriage assembly.

Capscrews (33 and 34) must be staked at three places equally spaced around the head after installation.

Steps 38 thru 40 apply to both modified and unmodified howitzers.

38 Install shim (31) and access cover (32).

39 Install 13 capscrews (33) and capscrew (34).

40 Install instruction plate (35) and four screws (36).

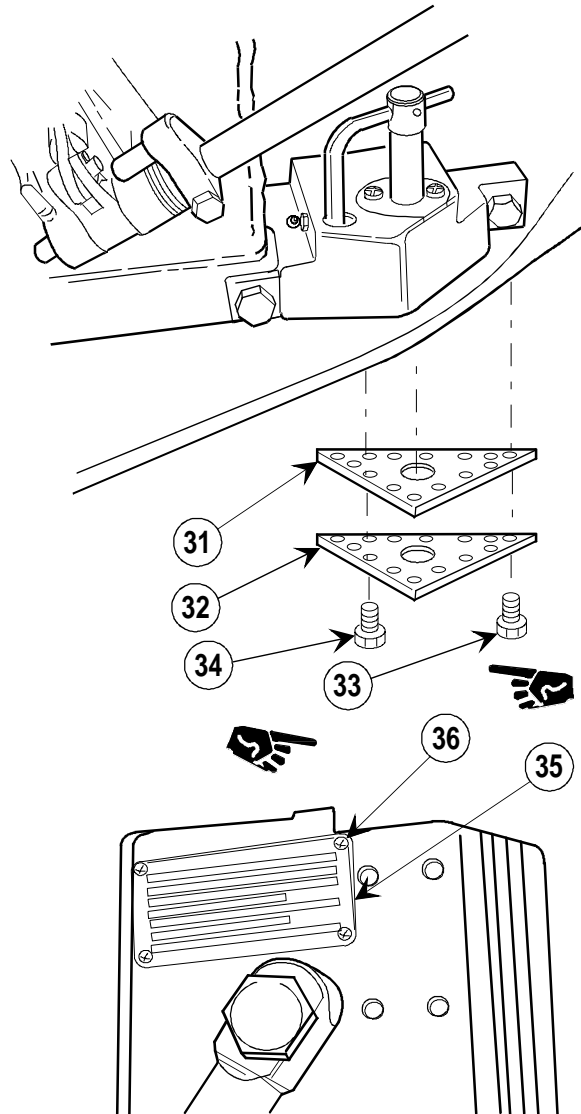

NOTE

Steps 41 thru 49 apply to howitzers that have been modified.

41 Install designation plate (37) and two screws (38).

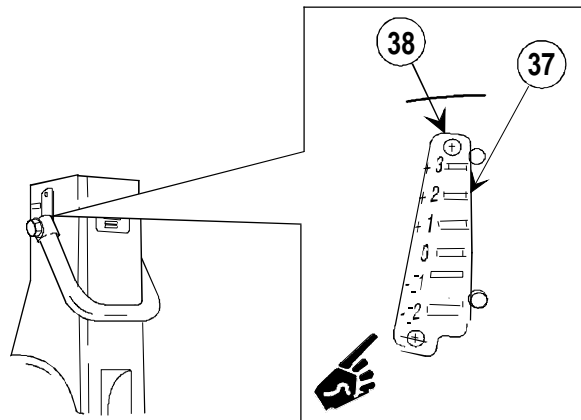

- 42 Install two slide assembly guides (39) and eight self-locking screws (40). Apply WTR grease to adjustment screw slide area of the guides.
- 43 Coat two threaded inserts (41) and mating holes in top carriage with primer (item 20, app B); install while primer is wet.
- 44 Install plate spacer (42) and two threaded inserts (41).
- 45 Apply light coat of WTR grease to shoulder bolt (43) and bracket (44), assemble, and install in slide assembly guides (39).

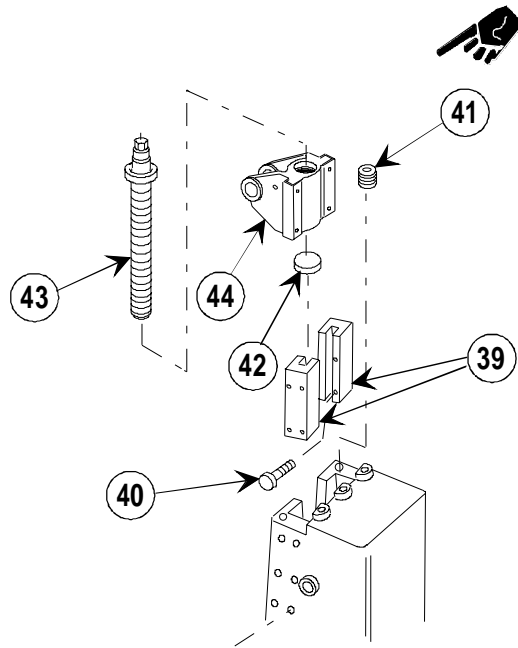

NOTE

There may be one or more races (45) depending on clearance between bearing (46) and counterbore on bracket (47).

If there is considerable movement in shoulder bolt (43) when bracket (47), bearing (46) and one or more races (45) are installed, try an additional race (four races, and one laminated shim). However, if bracket (47) does not set flat (has a rocky motion), remove one race (45). It should be placed between bearing (46) and bracket (47).

Shim must be adjusted to provide 0.005 in. (0.013 cm) clearance between access cover and bearing/races on shoulder screw.

- 46 Install races (45) and bearing (46).
- 47 Install shim (48).
- 48 Install bracket (47) and check for 0.005 in. (0.013 cm) clearance, adjust laminated shim as required to meet the 0.005 in. (0.013 cm) requirement.

CAUTION

Do not overtighten hex head bolts. Torque to 40 ft-lb (54.6 N-m).

Do not overtighten the capscrews. If capscrews are tightened too tight, the counterbored shoulder of the top carriage could be damaged.

- 49 Install two washers (49) and two hex head bolts (50); torque to 40 ft-lb (275.8 N-m). Install four capscrews (51) and tighten until contact is made with the counterbored surface of the top carriage.
- 50 Set the equilibrator adjustment screw pointer to "0" and charge equilibrators to 1750 psi at ambient temperature (TM 9-1025-211-20&P), service by charging with nitrogen procedures. Deviation of the procedure is necessary in step 15; the nitrogen pressure should be brought up to approximately 1500 psi and allowed to stabilize prior to regulating the pressure to 1750 psi.

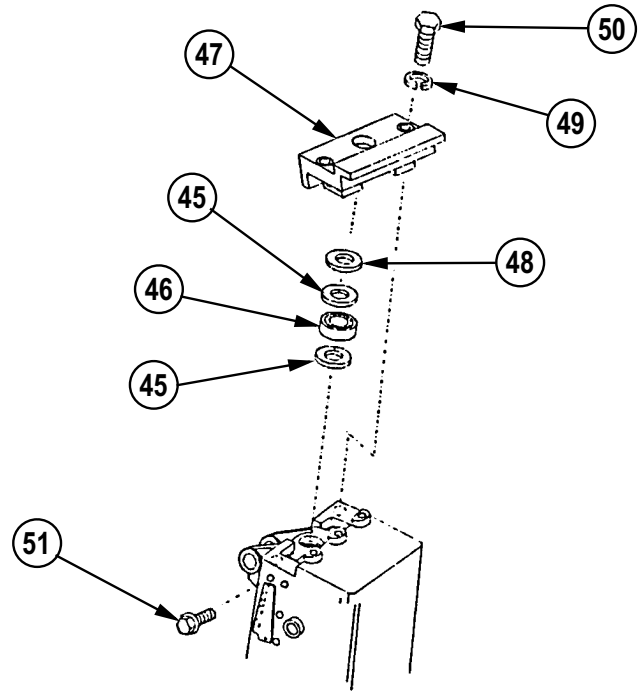

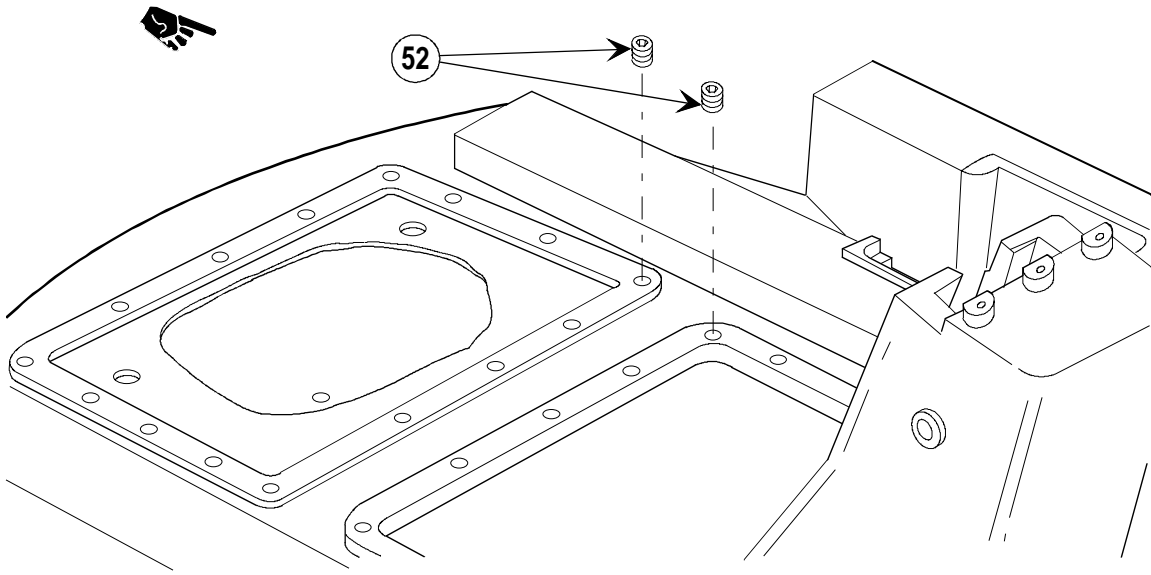

51 Install 28 inserts (52).

NOTE

Second gasket (53) and standoff cover (54) are on modified howitzers only.

- 52 Install four new gaskets (53).
- 53 Install two standoff covers (54).
- 54 Install two access covers (55).
- 55 Install 28 washers (56) and 28 capscrews (57).

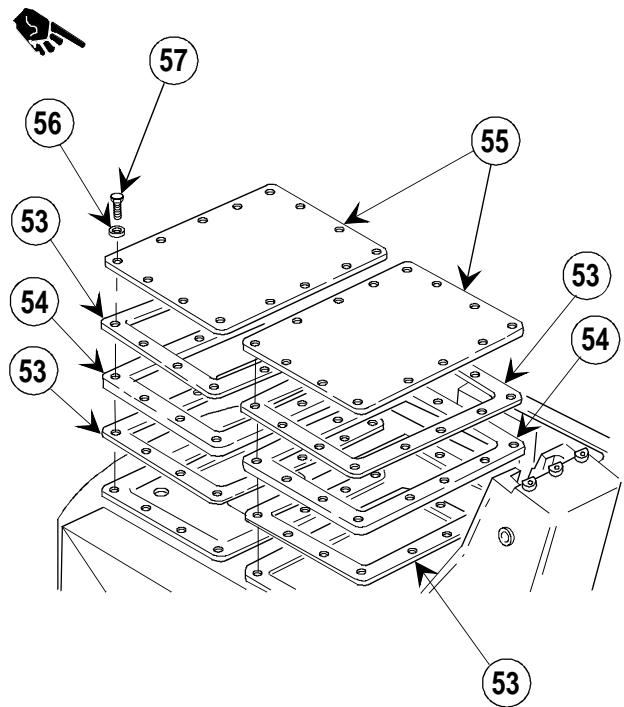

2-36. TOP CARRIAGE ASSEMBLY—MAINTENANCE INSTRUCTIONS (cont)

REASSEMBLY (cont)

- 56 Coat four threaded inserts (58) and mating holes with primer; install while primer is wet.
- 57 Install four sleeve bushings (59) in each set of elevation bearing caps (60).
- 58 Install two elevation bearing caps (60) with two lubrication fittings (61), two retaining straps (62), four lockwashers (63) and four bolts (64).

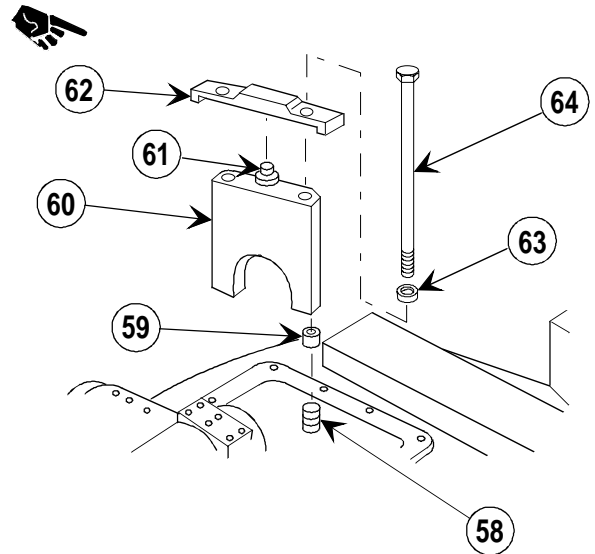

INSTALLATION

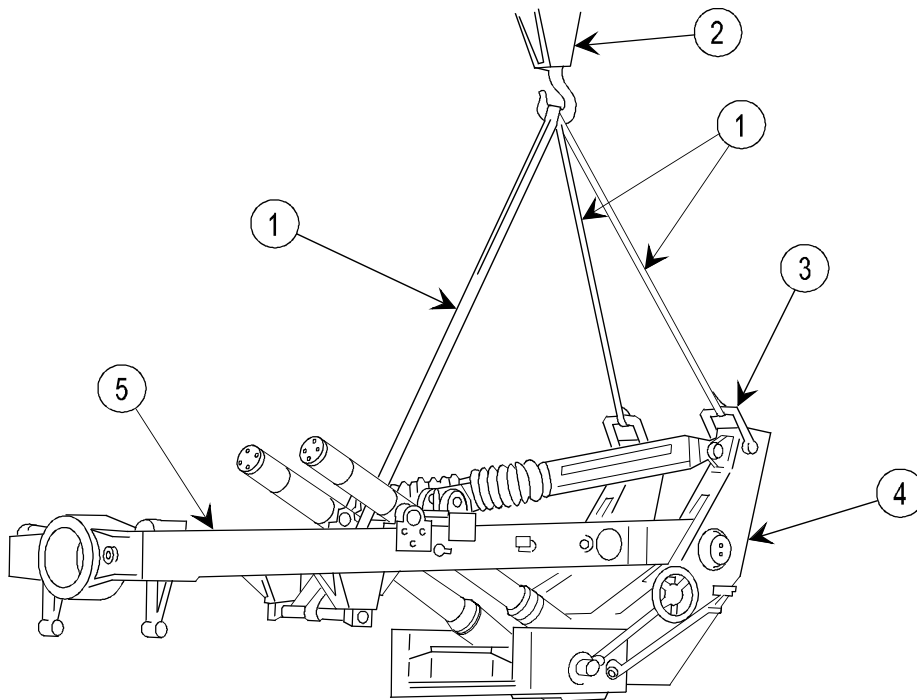

- 1 Attach slings (1) and 3-ton hoist (2) to hoisting link (3) of top carriage assembly (4) and cradle assembly (5).

- 2 Coat 48 threaded inserts (6) and mating holes with primer and install while primer is wet.

NOTE

Ensure internal gear mounting surface in bottom carriage is clean and drain holes in same surface are clear.

If internal gear has no more than six consecutive broken teeth, rotate the internal gear 180 degrees and align tapped hole with top carriage extension tube hole. The extension tube should be started in the tapped hole to ensure proper alignment of the top carriage and internal gear prior to bolting the internal gear to the top carriage. The broken teeth should now be in the area of the right trail. Mark the location of the broken teeth on the top and bottom carriage. If the broken teeth fall in any other area of the top and bottom carriage than over the right trail, the internal gear must be replaced. The location of the broken teeth should be noted in the howitzer log book and the crew informed as well.

- 3 Raise top carriage assembly (4) off blocks (7) to allow internal gear (8) to be positioned beneath it.
- 4 Position internal gear (8) 180 degrees from original position. If damaged internal gear is usable, or if it is a new internal gear, make sure that the tapped extension hole (9) in the internal gear aligns with the tube hole (10) in top carriage (4). Make certain the mounting holes are aligned.
- 5 If new internal gear is installed, lubricate (TM 9-1025-211-10, appx F).
- 6 Deleted.
- 7 Align holes in top carriage (4) and internal gear (8) and start extension tube (11) into threaded hole (9) in internal gear. Lower top carriage onto internal gear.

NOTE

Internal gear lubrication fitting extension in top carriage assembly has to align with lubrication hole in internal gear.

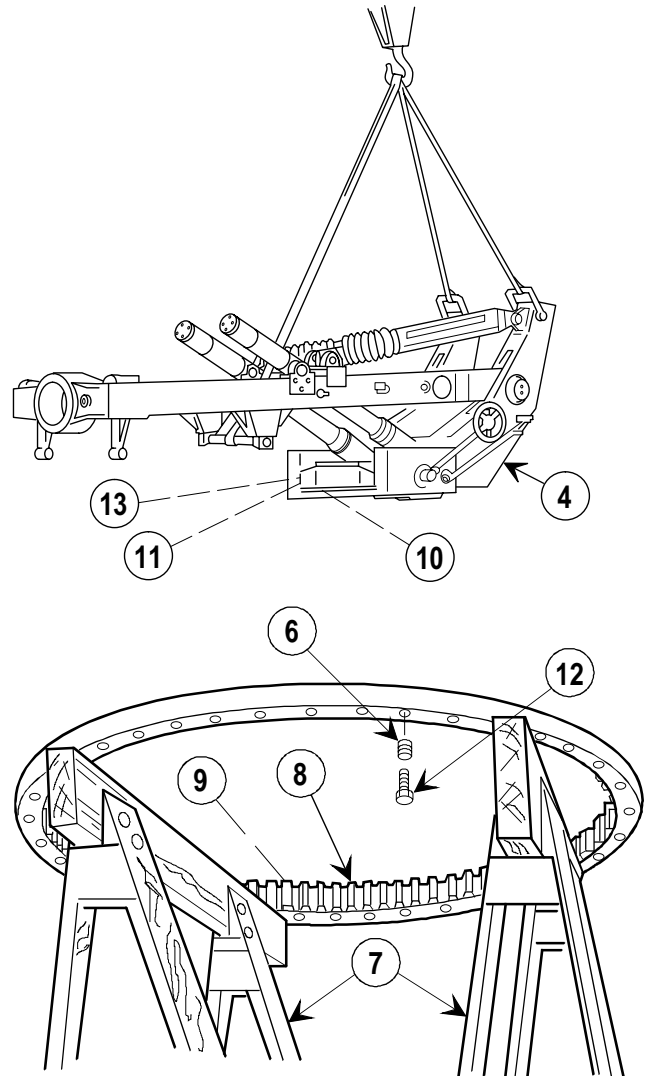

NOTE

Steps 7.1 thru 11 pertain to installation of 48 bolts.

- 7.1 Apply sealing compound (item 28.1, appx B) to threads of bolts (12) prior to installation.
- 8 Install and tighten two bolts (12) side by side.
- 9 At a 180-degree angle from the two tightened bolts, install two more bolts (12) and tighten.

NOTE

Raise top carriage assembly (4) enough to rotate position on blocks (7) to gain access to install remainder of bolts.

- 10 Install and tighten remaining 44 bolts (12), extension tube (11), and install and tighten grease fitting (13).
- 11 Torque 48 bolts to 80 to 85 ft-lb (109 to 115 N-m).

2-36. TOP CARRIAGE ASSEMBLY—MAINTENANCE INSTRUCTIONS (cont)

INSTALLATION (cont)

CAUTION

Make sure no pressure is exerted on the rubber seal when connecting top carriage assembly to bottom carriage assembly.

NOTE

Make sure internal gear lines up with mounting holes in bottom carriage assembly before the weight of the top carriage assembly (4) rests completely on the bottom carriage assembly.

- 12 Raise top carriage assembly (4) off of supports, and lower onto bottom carriage assembly.

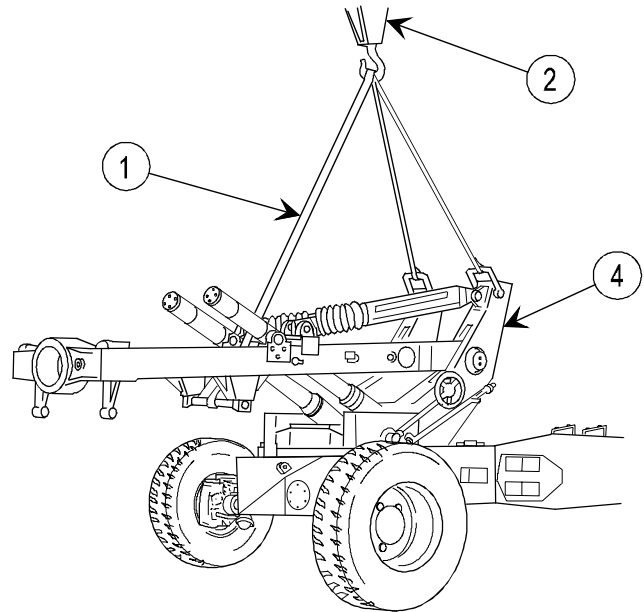

- 13 Apply sealing compound to threads of 64 capscrews (14) prior to installation. While rotating top carriage (4), install and torque 64 capscrews to 80 to 85 ft-lb (109 to 115 N-m).

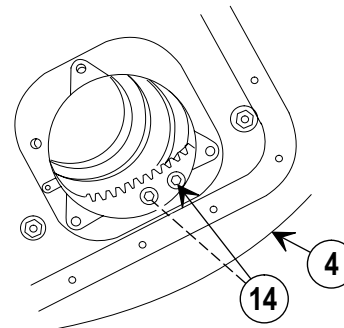

- 14 Remove sling (1) and 3-ton hoist (2).

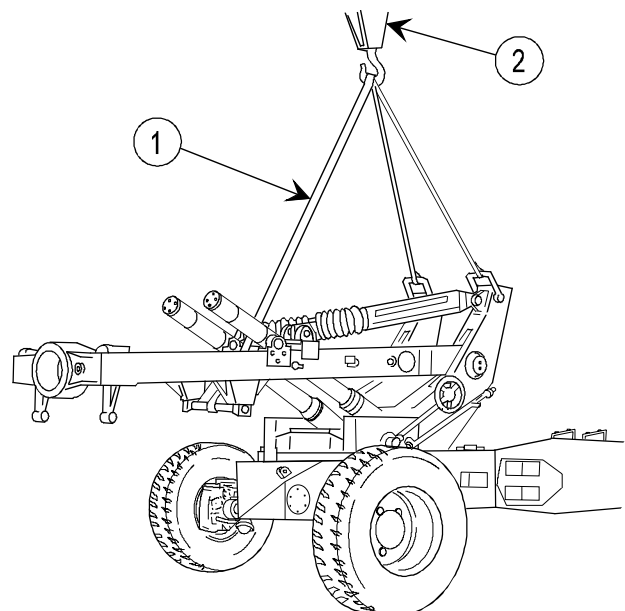

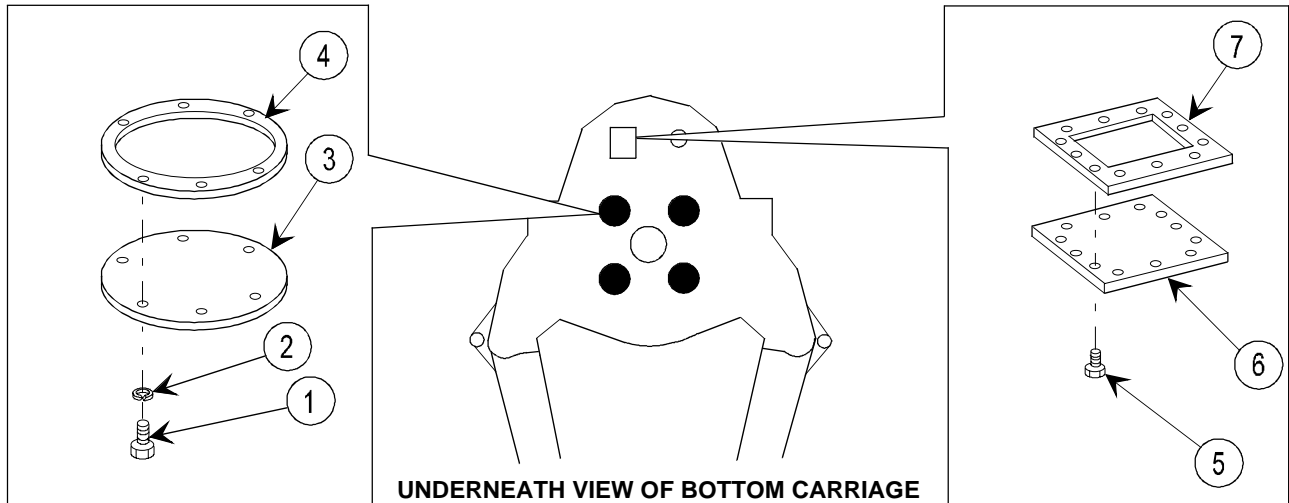

- 1 Remove six capscrews (1) and six lockwashers (2).
- 2 Remove access cover (3) and gasket (4).
- 3 Remove 12 capscrews (5).
- 4 Remove access cover (6) and gasket (7).

NOTE

Do not remove nuts (8) unless necessary for replacement.

- 5 Remove twelve nuts (8).

WARNING

There are two wheel lock handles. Repair one side at a time.

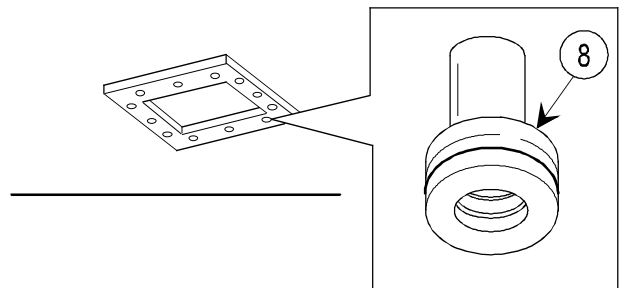

NOTE

Wheel lock handle must be in unlocked position (TM 9-1025-211-10).

- 6 Remove lubrication fitting (9).
- 7 Drive out pin (10).
- 8 Remove wheel lock handle (11).

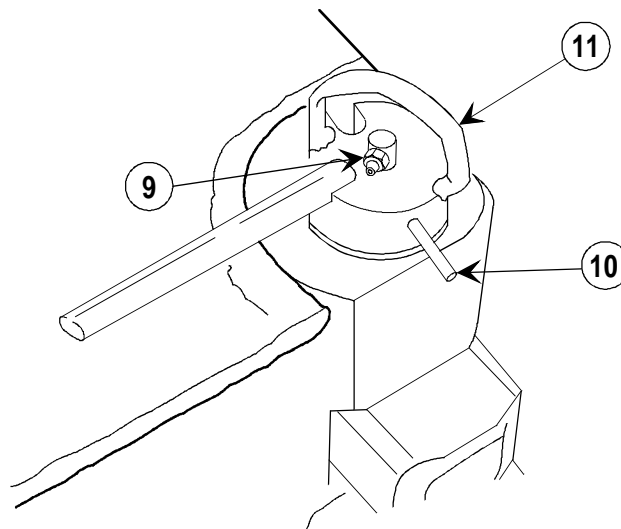

2-38. BOTTOM CARRIAGE ASSEMBLY—MAINTENANCE INSTRUCTIONS (cont)

DISASSEMBLY (cont)

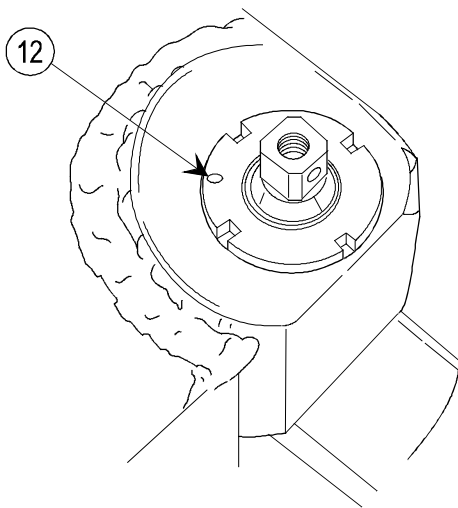

9 Remove setscrew (12).

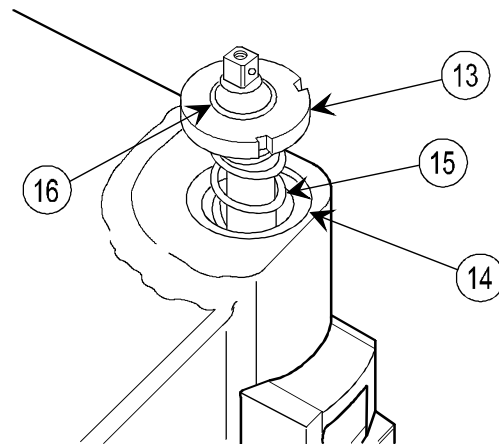

CAUTION

Bushing (13) is under spring tension.

10 Remove bushing (13) and gasket (14).

11 Remove spring (15).

12 Remove rotor seal (16).

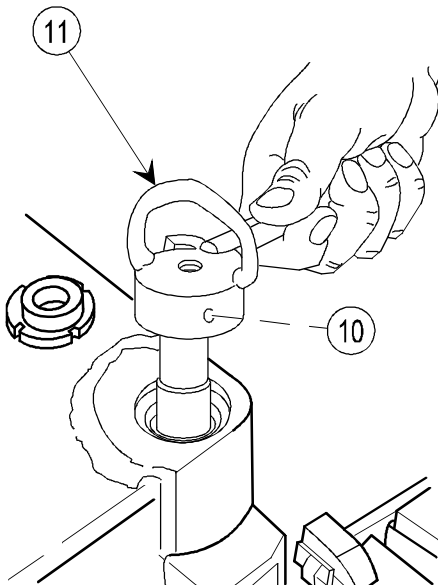

13 Install wheel lock handle (11).

14 Install pin (10).

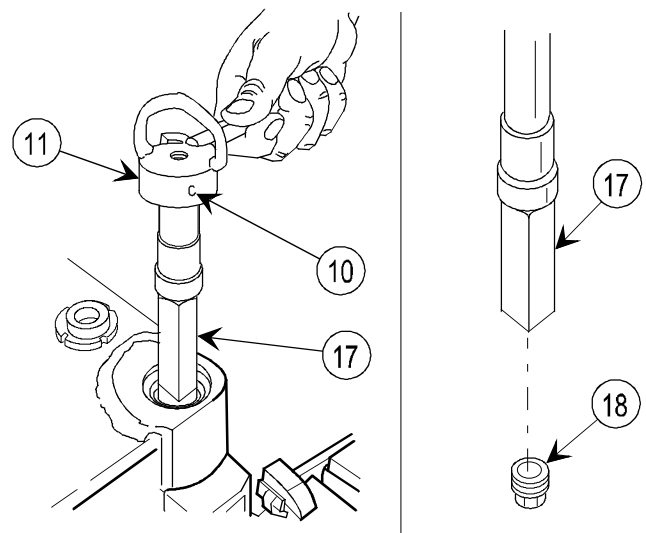

15 Remove shouldered shaft (17) by lifting wheel lock handle (11).

16 Remove pin (10).

17 Remove wheel lock handle (11).

18 Remove pipe plug (18) from shouldered shaft (17).

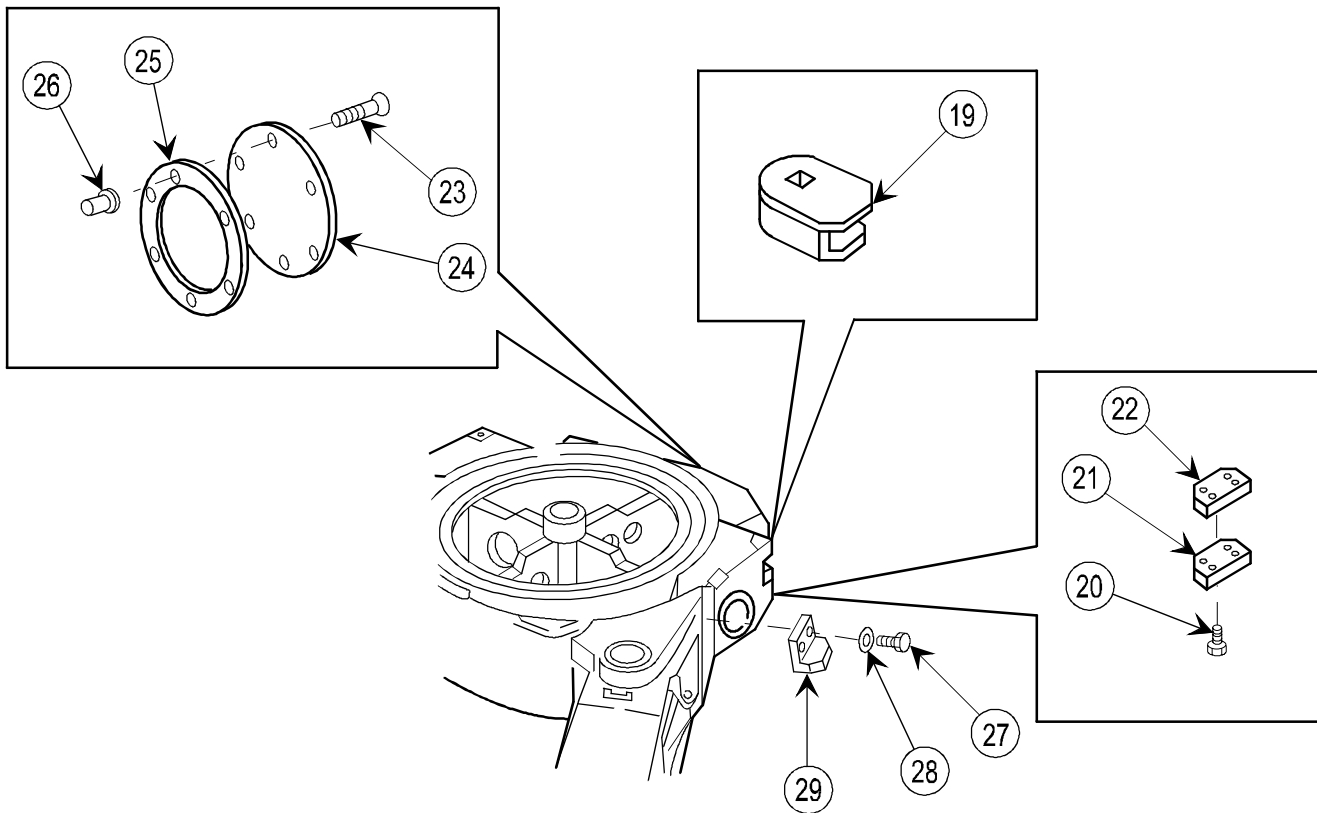

19 Remove wheel lock support (19).

20 Remove lock wire and four screws (20).

21 Remove access cover (21) and gasket (22).

22 Remove 18 capscrews (23), three access covers (24), and three gaskets (25).

23 Remove 18 cap plugs (26).

24 Remove four bolts (27), four flat washers (28), and two angle brackets (29) (modified howitzers only).

NOTE

Do not remove cap plugs (26) unless necessary for replacement.

2-38. BOTTOM CARRIAGE ASSEMBLY—MAINTENANCE INSTRUCTIONS (cont)

DISASSEMBLY (cont)

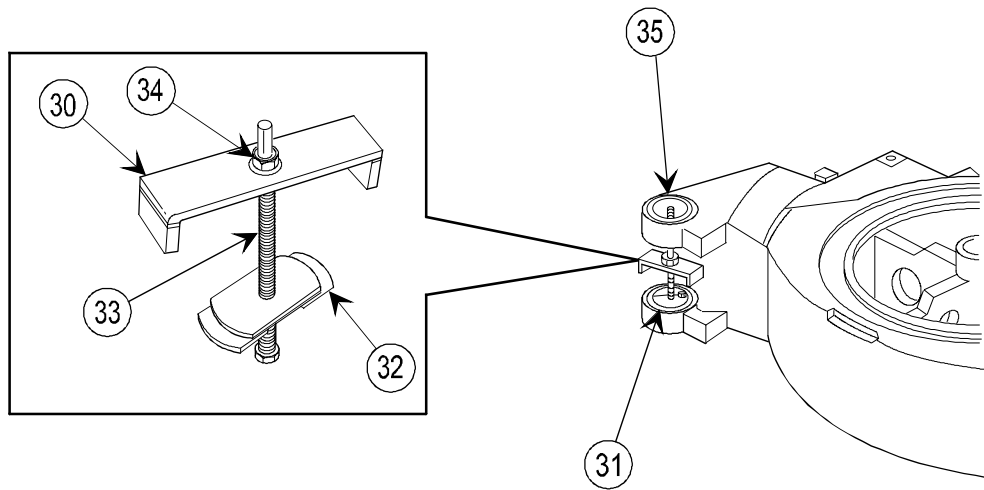

NOTE

The upper and lower bushings have different outside diameters. Select the correct diameter plate (identified in fabrication instructions) as required to pull bushing.

- 25 Position puller plate assembly (30) over first bushing (31) to be removed.
- 26 Select the correct size plate (32), screw onto rod (33), and center on bushing.
- 27 Turn nut (34) pulling bushing (31) from bottom carriage.
- 28 Remove bushing (35) in same manner.

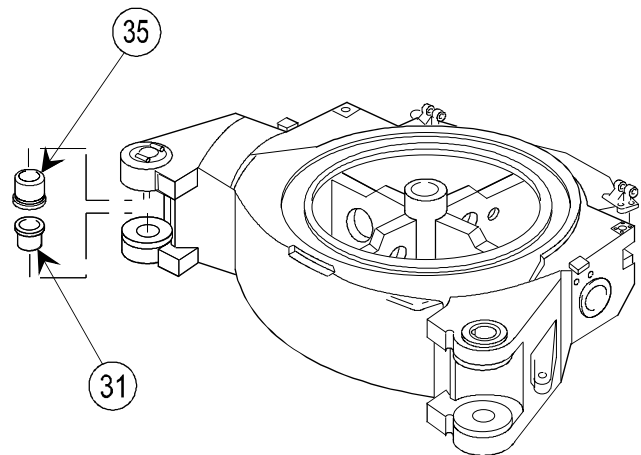

- 29 Remove seal (36).

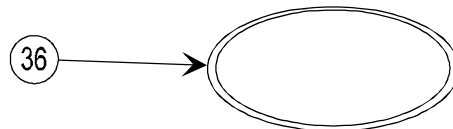

INSPECTION/REPAIR

- 1 Check for broken, damaged, or missing parts.
- 2 Repair is by replacement of authorized parts (TM 9-1025-211-34P).

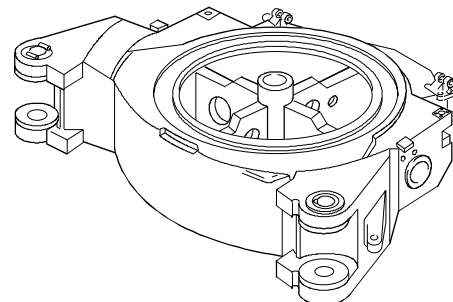

REASSEMBLY

- 1 Lubricate new seal (1) with WTR grease and install.
- 2 Position bushings (2 and 3) on carriage assembly.
- 3 Install bushings in bottom carriage. Use puller in reverse order if necessary.

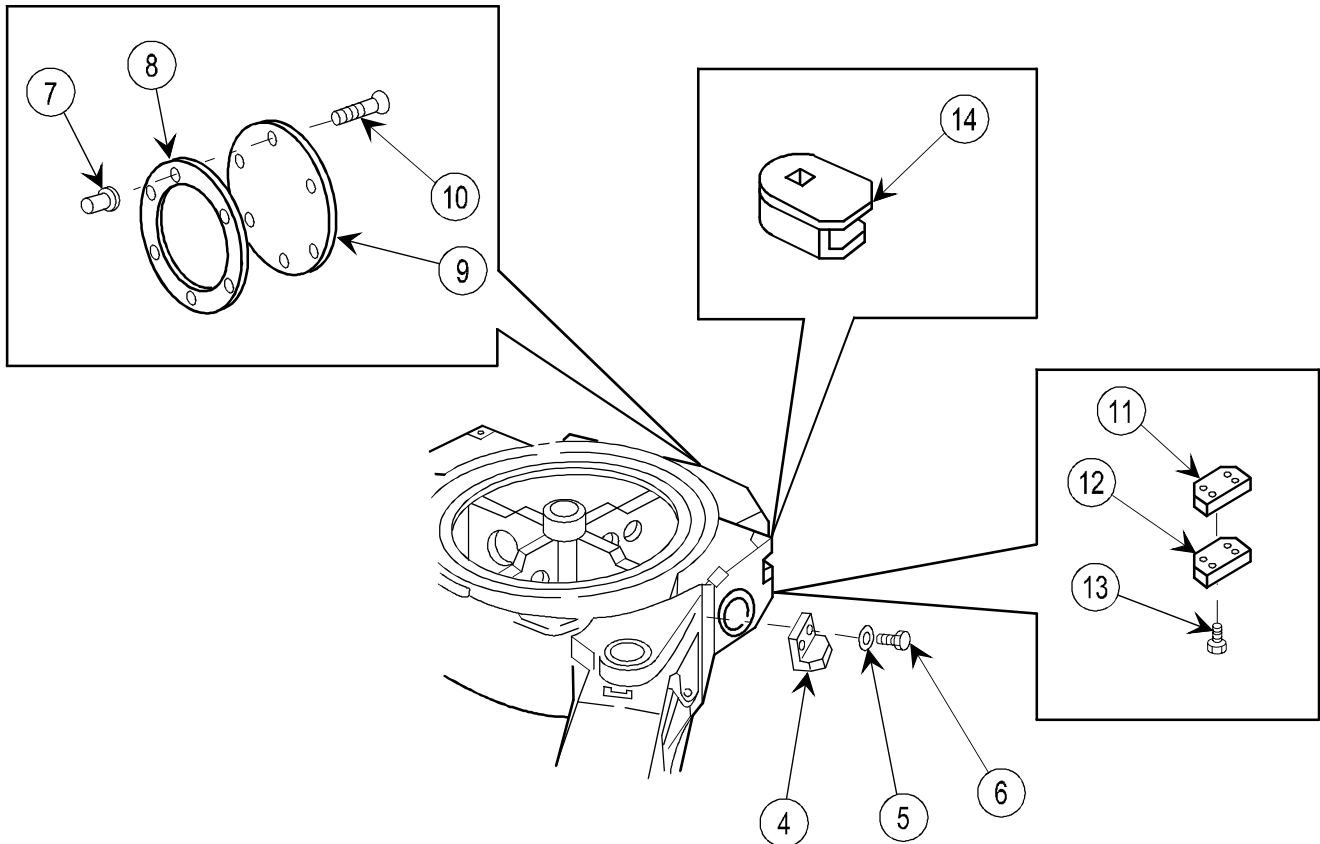
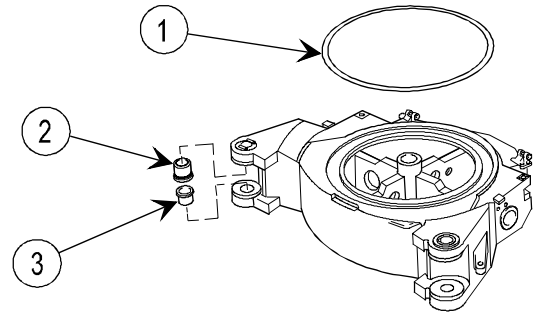

- 4 Install two angle brackets (4), four flat washers (5) and four bolts (6) (modified howitzers only).
- 5 If removed, install 18 cap plugs (7) in bottom carriage.
- 6 Install three new gaskets (8), three access covers (9), and 18 capscrews (10).
- 7 Install two new gaskets (11) and access covers (12).
- 8 Install four screws (13) and lock wire (item 34, appx B).
- 9 Install wheel lock support (14).

2-38. BOTTOM CARRIAGE ASSEMBLY—MAINTENANCE INSTRUCTIONS (cont)

REASSEMBLY (cont)

10 Install pipe plug (15) in shouldered shaft (16).

11 Install new rotor seal (17).

NOTE

Wheel lock handle pin hole in shouldered shaft (16) should be 90 degrees from wheel and tire when wheel lock support is in unlocked position.

12 Install shouldered shaft (16).

13 Install spring (18).

14 Install new gasket (19) and bushing (20).

15 Install setscrew (21).

16 Install wheel lock handle (22).

17 Install pin (23).

18 Install lubrication fitting (24).

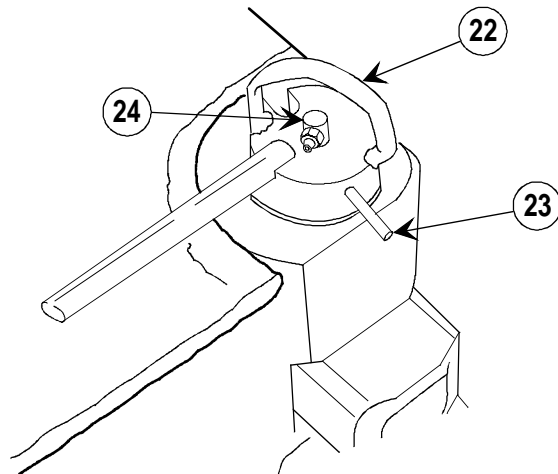
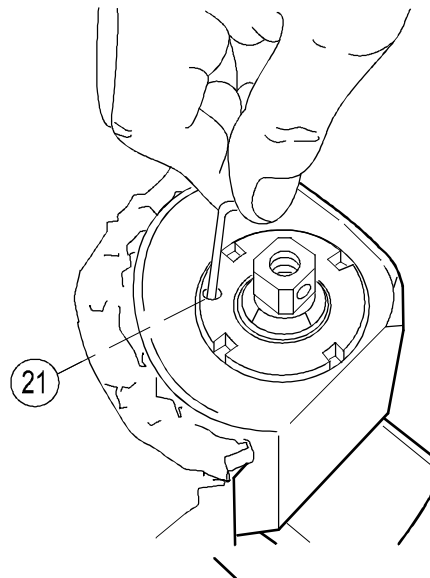
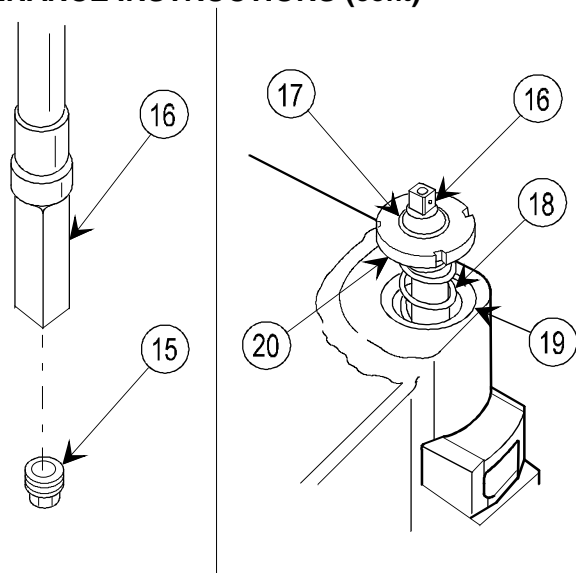

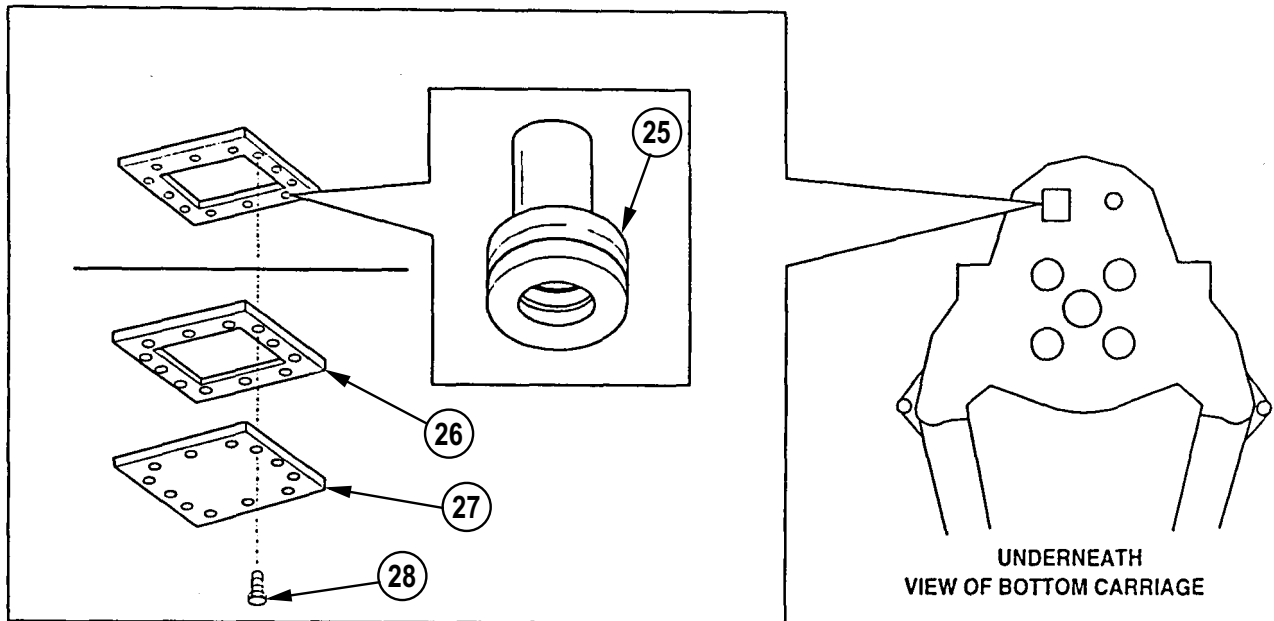

- 19 If removed, install 12 nuts (25) in bottom carriage.
- 20 Install new gaskets (26) and access covers (27).
- 21 Install 12 cap screws (28).

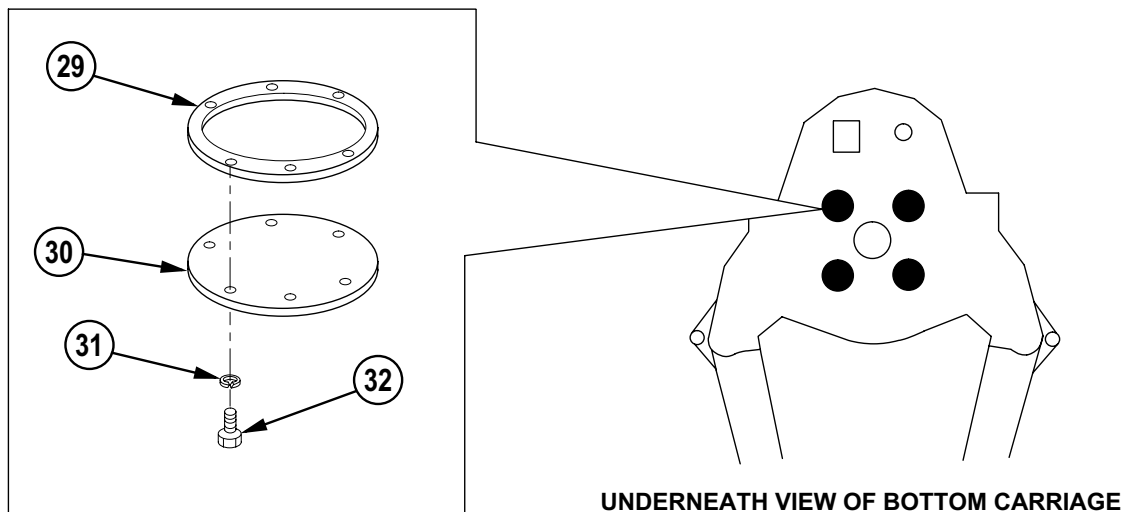

- 22 Install new gasket (29) and access cover (30).
- 23 Install six lockwashers (31) and six cap screws (32). Torque to 3 ft-lb (4 N-m).

2-38.1. HyPAK SOLENOID—MAINTENANCE INSTRUCTIONS

THIS TASK COVERS:		
a. Disassembly	b. Inspection/repair	c. Reassembly
INITIAL SETUP		
Tools and Special Tools Artillery field maintenance shop equipment (SC 4933-95-A12) Marine Corps general tool box (C6490) Multimeter		
Materials/Parts Electrical tape (item 32.1, appx B) Lockwasher (8) (MS35338-41) Lockwasher (6) (MS35338-43) Lock wire (item 37, appx B)		
References TM 9-1025-211-34P		

DISASSEMBLY

NOTE

Disassemble solenoid box in a clean area. Retain all hardware and protect cable assemblies and seals from damage.

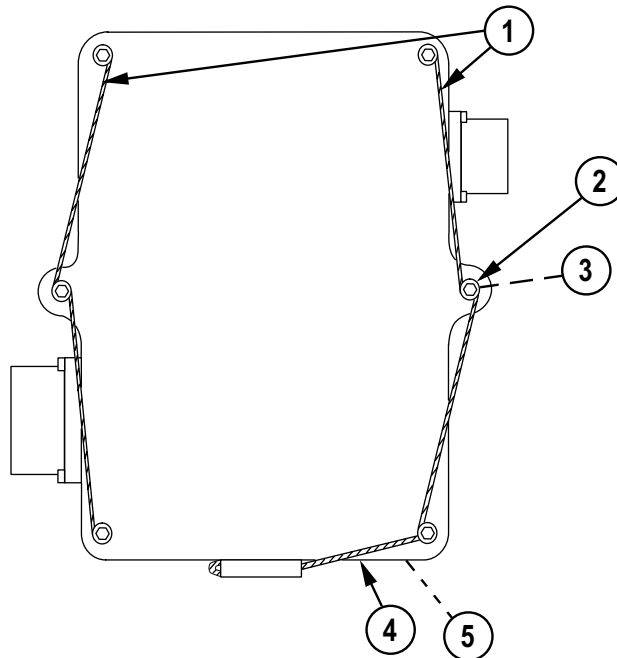

- 1 Remove lock wire (1), six externally relieved bolts (2), and six lockwashers (3). Discard lockwashers.
- 2 Remove access cover (4) and gasket (5). Retain gasket.

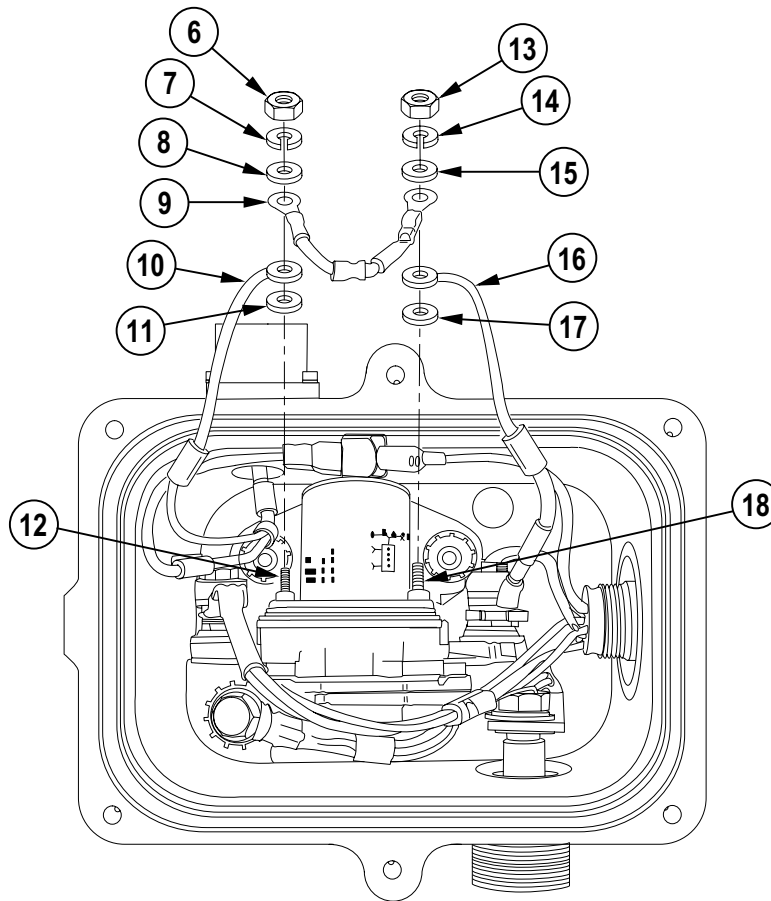

- 3 Remove nut (6), lockwasher (7), flat washer (8), diode (9), switch connector lead (10), and flat washer (11) from small stud X1 (12).
- 4 Remove nut (13), lockwasher (14), flat washer (15), diode (9), eyelet of jumper wire (16), and flat washer (17) from small stud X2 (18).

2-38.1. HyPAK SOLENOID—MAINTENANCE INSTRUCTIONS (cont)

DISASSEMBLY (cont)

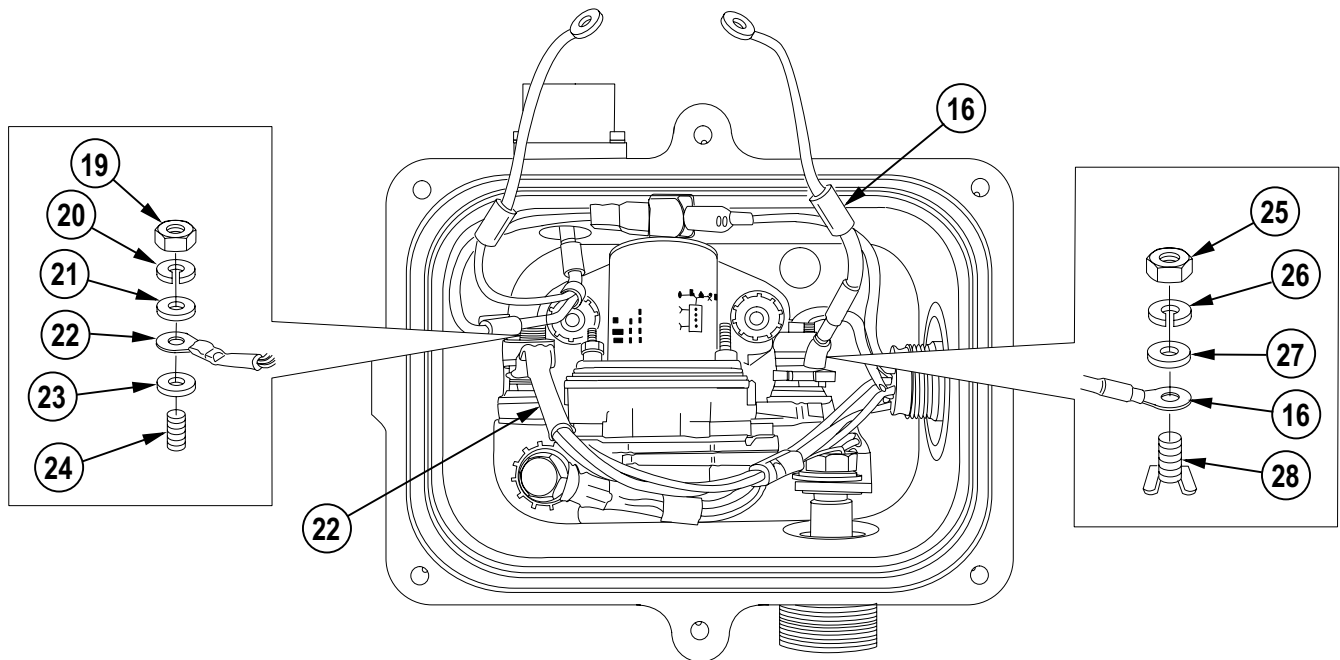

- 5 Remove nut (19), lockwasher (20), flat washer (21), pump connector A1 wire set (22), and flat washer (23) from large stud A1 (24).
- 6 Remove nut (25), lockwasher (26), flat washer (27), and jumper wire (16) from large stud A2 (28).

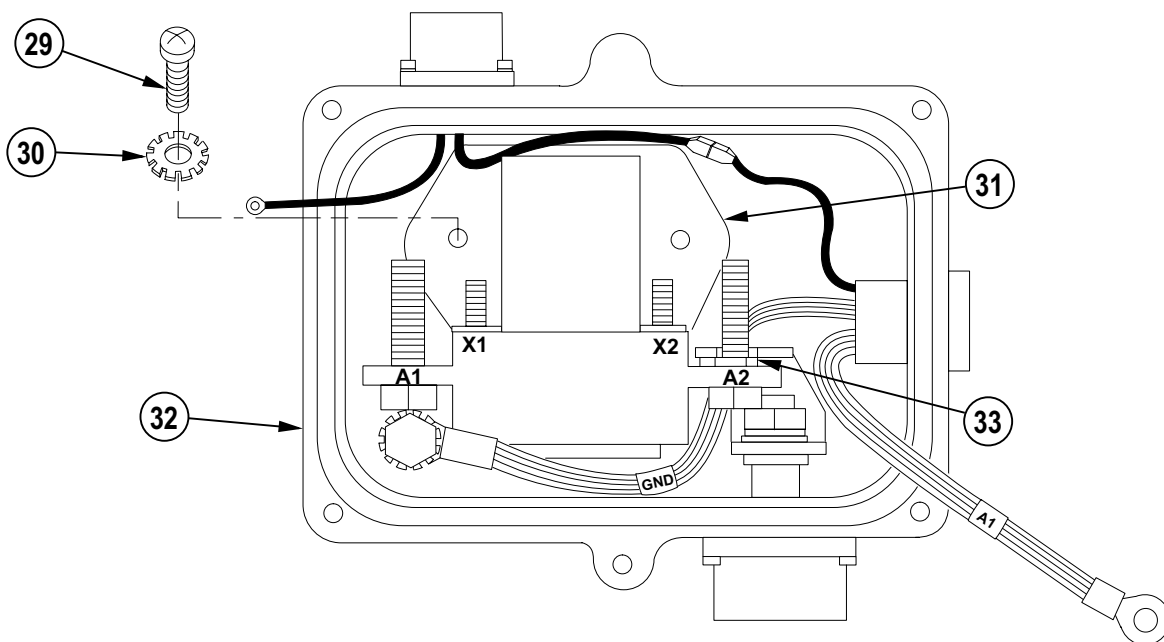

- 7 Remove two screws (29) and two washers (30) securing relay (31) to terminal box (32). Discard washers.
- 8 Remove relay (31) from terminal box (32). Remove flat washer (33) from large stud A2 (28).

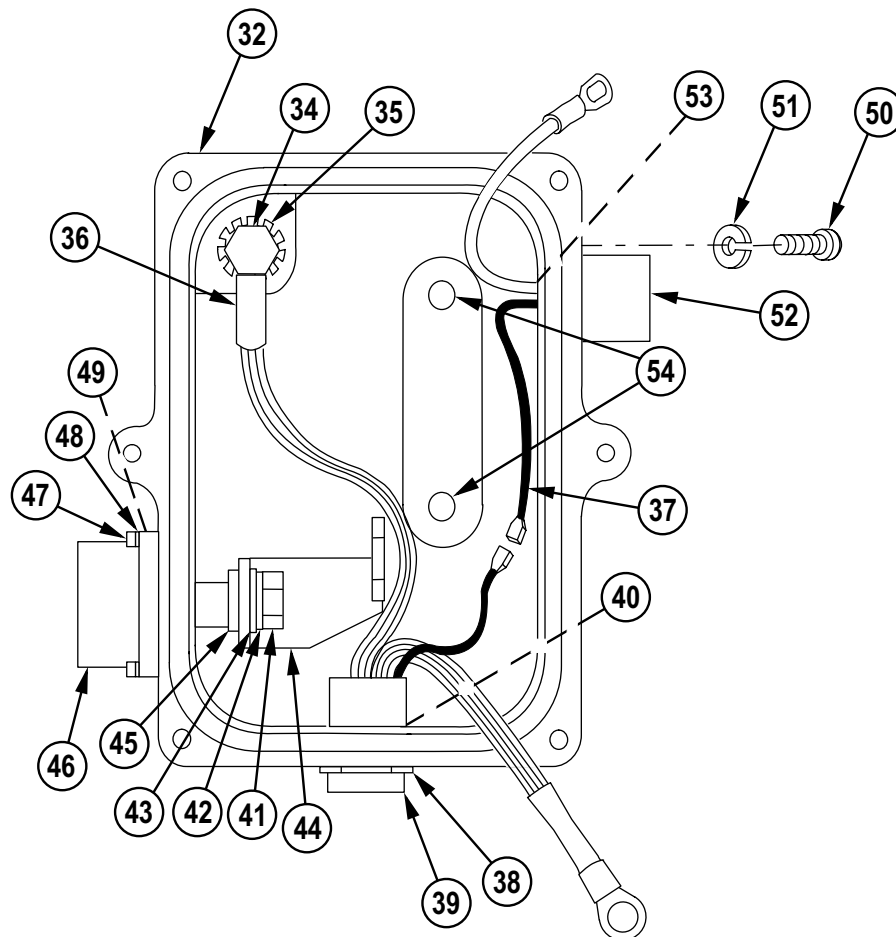

- 9 Remove hexagon head cap screw (34), star washer (35), and pump connector ground (GND) wire set (36) from terminal box (32). Discard star washer.
- 10 Disconnect spade connector (37).
- 11 Remove lockwire and nut (38) from pump connector (39).
- 12 Remove pump connector (39) from terminal box (32).
- 13 Remove O-ring (40) from pump connector (39). Retain O-ring.
- 14 Remove nut (41), lockwasher (42), flat washer (43), electrical contact (44), and washer (45) from power connector (46).
- 15 Remove four machine screws (47), four lockwashers (48), power connector (46), and gasket (49) from terminal box (32). Retain lockwashers and gasket, unless unserviceable.
- 16 Remove four machine screws (50) and four lockwashers (51) from switch connector (52). Remove switch connector and gasket (53). Discard lockwashers. Retain gasket.
- 17 If damaged, remove two screw thread inserts (54) from terminal box (32).

2-38.1. HyPAK SOLENOID—MAINTENANCE INSTRUCTIONS (cont)

INSPECTION/REPAIR

- 1 Check for broken, damaged, or missing parts.
- 2 Repair is by replacement of authorized parts (TM 9-1025-211-34P).

REASSEMBLY

NOTE

Assemble solenoid box in a clean area. Reuse as much hardware from disassembly procedure as possible and protect wires and seals from damage.

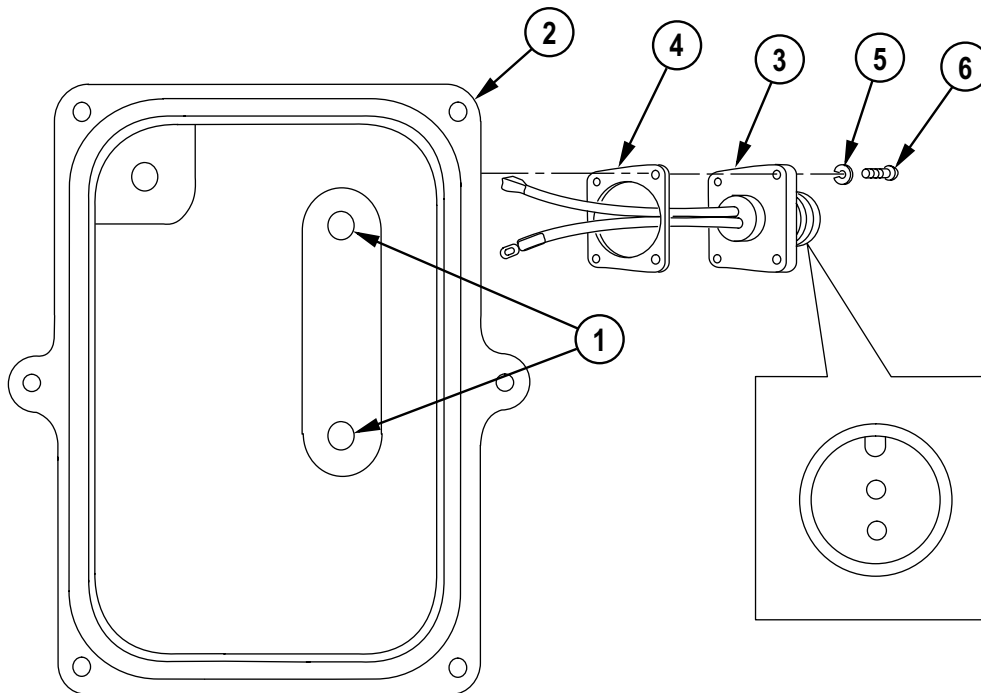

- 1 If removed, install two new screw thread inserts (1) in terminal box (2).
- 2 Guide wires of switch connector (3) through gasket (4) and opening in terminal box (2). Orient timing key toward top of terminal box. Align holes in gasket and switch connector with four threaded holes in terminal box. Install four new lockwashers (5) and four machine screws (6) and tighten.

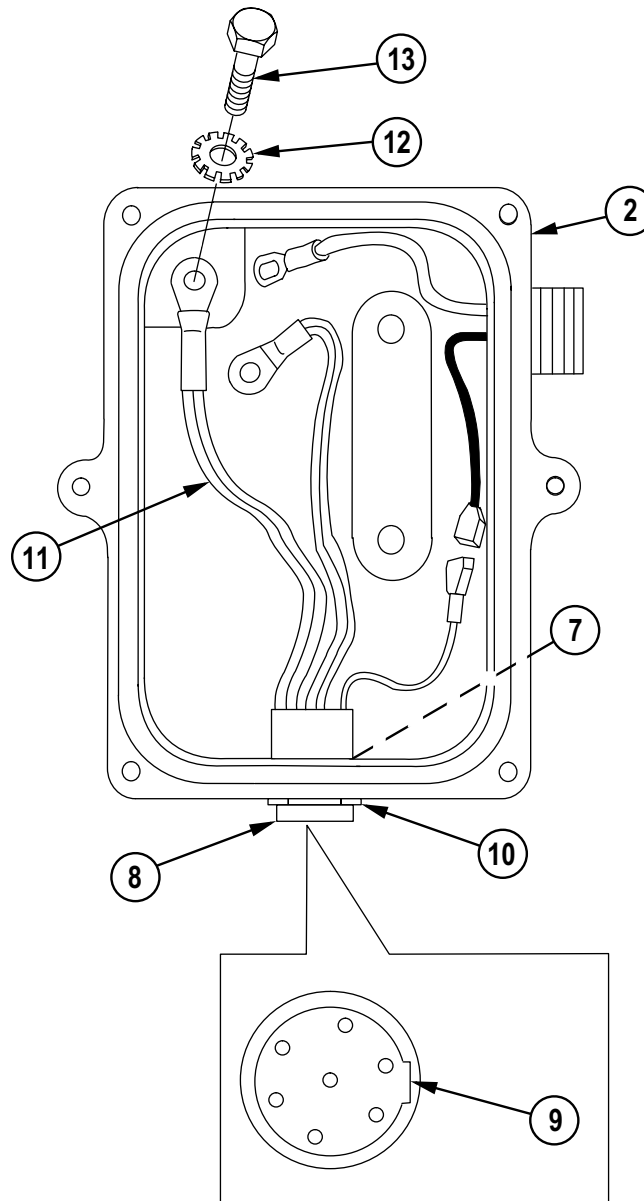

- 3 Place O-ring (7) in groove of pump connector (8). Starting on the inside of the terminal box (2), guide pump connector through opening in terminal box. With terminal box placed in an upright position, orient large timing groove (9) toward "3 o'clock" position and install nut (10). Tighten nut.
- 4 Place pump connector ground (GND) wire set (11) in terminal box (2). Align eyelet of GND wire set with threaded hole in bottom of terminal box and install star washer (12) and hexagon head cap screw (13). Tighten.

2-38.1. HyPAK SOLENOID—MAINTENANCE INSTRUCTIONS (cont)

REASSEMBLY (cont)

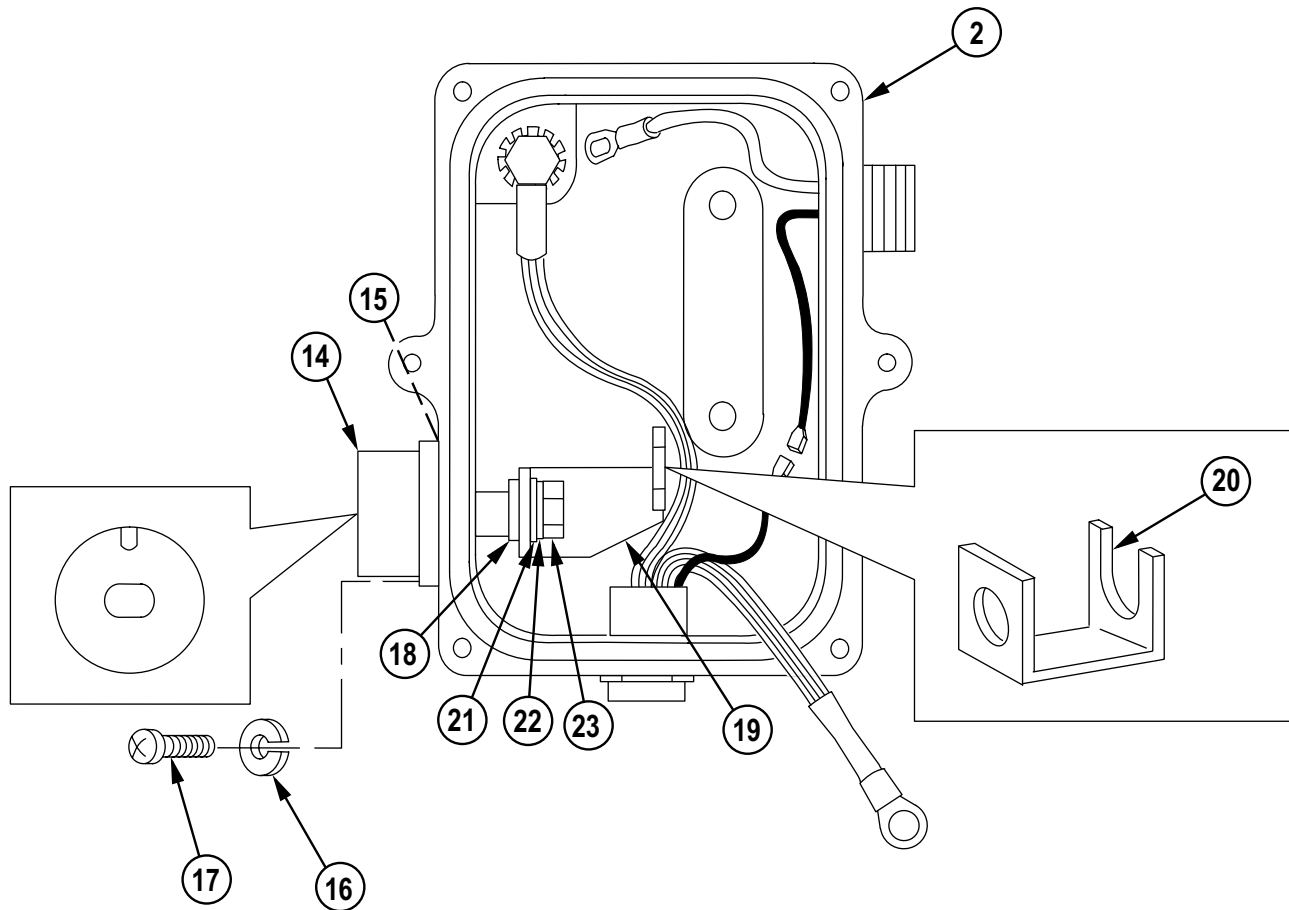

- 5 Guide power connector (14) through gasket (15) and opening in terminal box (2). Orient timing key toward top of terminal box. Align holes in gasket and power connector with four threaded holes in terminal box. Install four new lockwashers (16) and four machine screws (17) and tighten.

NOTE

Ensure that bottom surface of electrical contact is insulated, i.e. wrapped with electrical tape.

Flat washer MS27183-14 may be used as required for shimming.

- 6 Install one flat washer (18) on stud of power connector (14). Align hole of electrical contact (19) with stud of power connector. Orient "U" slot (20) of electrical contact to be perpendicular to bottom of terminal box (2), with the opening pointing up. Install flat washer (21), lockwasher (22), and nut (23) on stud of power connector. Tighten nut.

CAUTION

Protect all wires from damage.

NOTE

The large studs on the relay are labeled A1 and A2; these labels are visible from the top after installation. The small studs on the relay are labeled X1 and X2 on the bottom of the relay; these labels are not visible after installation. X1 stud is next to the large stud A1 and X2 stud is next to the large stud A2.

Proper installation of the relay captures the flat washer on large stud A2 with the electrical contact.

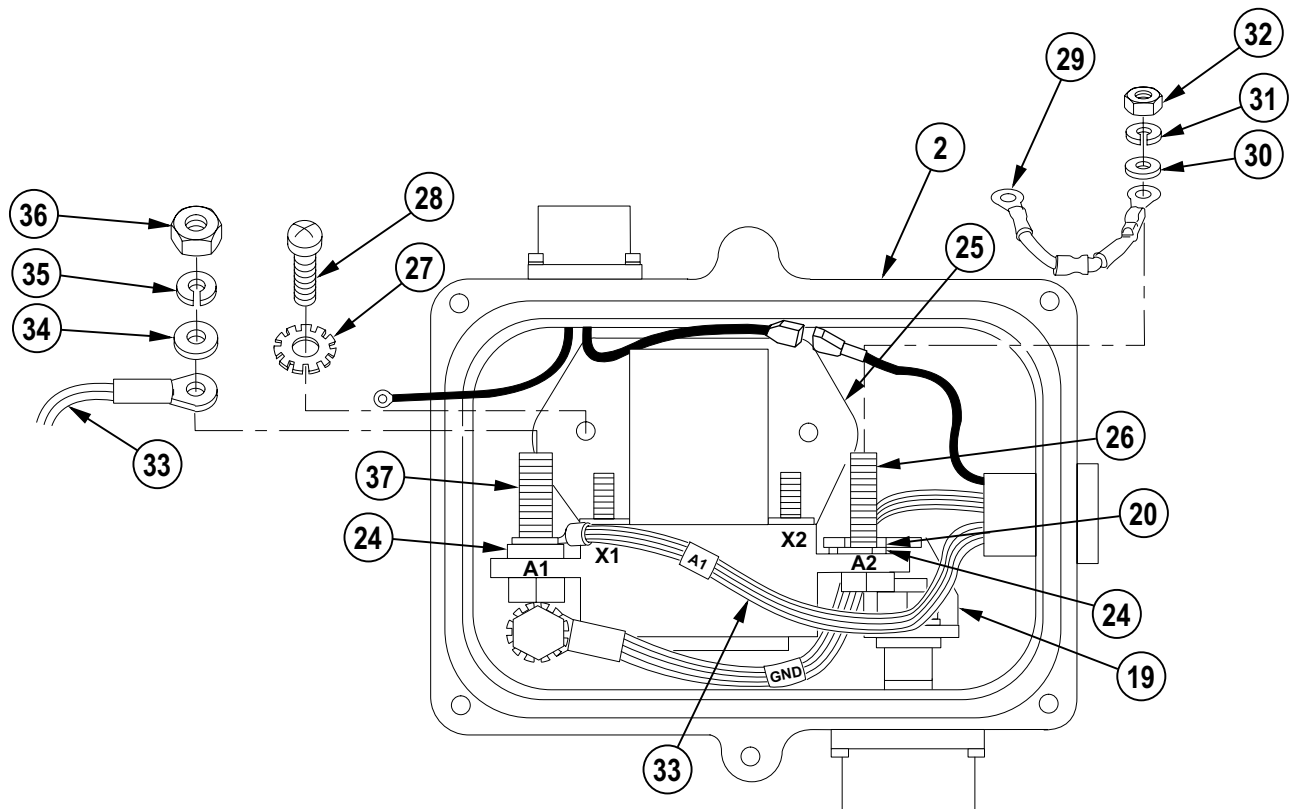

- 7 Install one flat washer (24) over each of the large studs on the relay (25). Guide large stud A2 (26) into "U" slot (20) of electrical contact (19) while aligning two holes in mounting flange of relay with two threaded holes in terminal box (2). Install two washers (27) and two screws (28). Seat but do not tighten screws at this time.
- 8 Install large eyelet of jumper wire (29), flat washer (30), lockwasher (31), and nut (32) onto large stud A2 (26). Tighten nut and then tighten two screws (28).
- 9 Install eyelet of pump connector A1 wire set (33), flat washer (34), lockwasher (35), and nut (36) onto large stud A1 (37). Tighten nut.

2-38.1. HyPAK SOLENOID—MAINTENANCE INSTRUCTIONS (cont)

REASSEMBLY (cont)

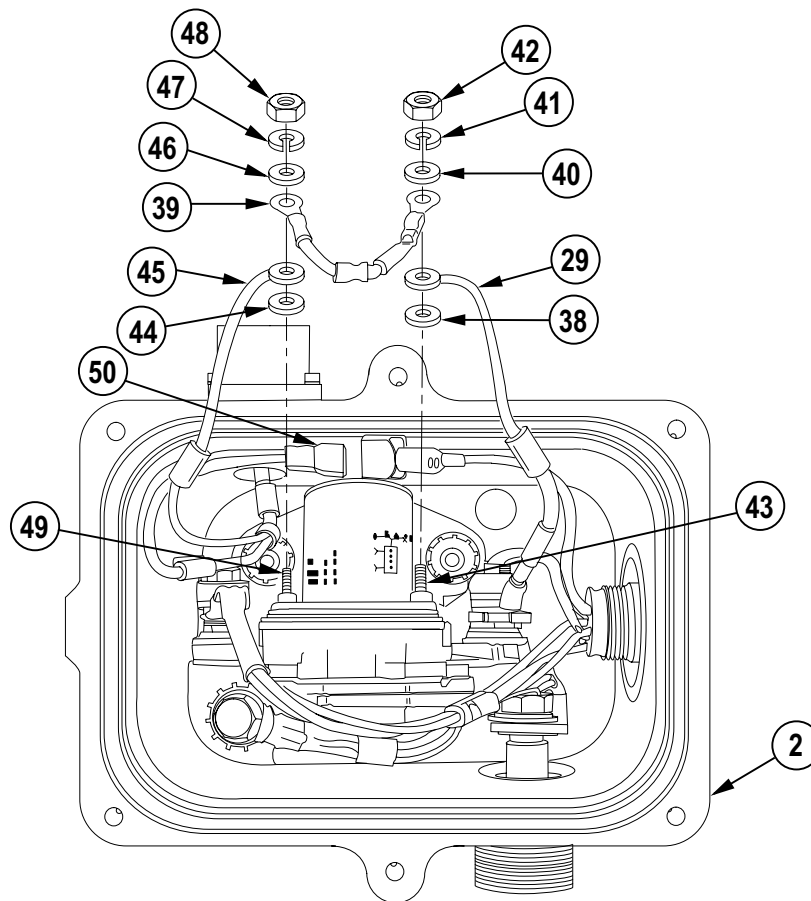

CAUTION

To prevent equipment damage, do not overtighten nuts on small studs.

NOTE

Perform resistance test on diode before installation. Refer to Circuit Resistance Chart.

- 10 Install flat washer (38), small eyelet of jumper wire (29), eyelet on red side of diode (39), flat washer (40), lockwasher (41), and nut (42) onto small stud X2 (43). Tighten nut.
- 11 Install flat washer (44), eyelet of switch connector lead (45), eyelet on black side of diode (39), flat washer (46), lockwasher (47), and nut (48) onto small stud X1 (49). Tighten nut.
- 12 Connect spade connector (50).
- 13 Perform circuit resistance test on terminal box (2) prior to installing cover. Use Circuit Resistance Chart for test.

Circuit Resistance Chart

1. Diode Resistance Test. Visually inspect diode for damage. Diode must be removed from terminal box for test. Use the multimeter's diode mode to check for resistance. Ensure proper polarity of test leads.

<u>Circuit Positive (+) Lead</u>		<u>Negative (-) Lead</u>	<u>Meter Reading</u>
X2 eyelet (red)	to	X1 eyelet (black)	0.7 volts or less
X1 eyelet (black)	to	X2 eyelet (red)	Open or "0"

2. Circuit Resistance Test. Do not activate relay. Measure the resistance of each circuit. Ensure proper polarity of test leads.

<u>Circuit Positive (+) Lead</u>		<u>Negative (-) Lead</u>	<u>D.C. Resistance Measured</u>
J73-A	to	J79	10 ohms or less
J73-B	to	J76-G	1 ohm or less
J76-H	to	Case	1 ohm or less
J76-A	to	Case	1 ohm or less
J76-E	to	Case	1 ohm or less
J76-C	to	Case	1 ohm or less
J76-B	to	J76-D	1 ohm or less
J76-B	to	J76-F	1 ohm or less
J76-D	to	J76-F	1 ohm of less

2-38.1. HyPAK SOLENOID—MAINTENANCE INSTRUCTIONS (cont)

REASSEMBLY (cont)

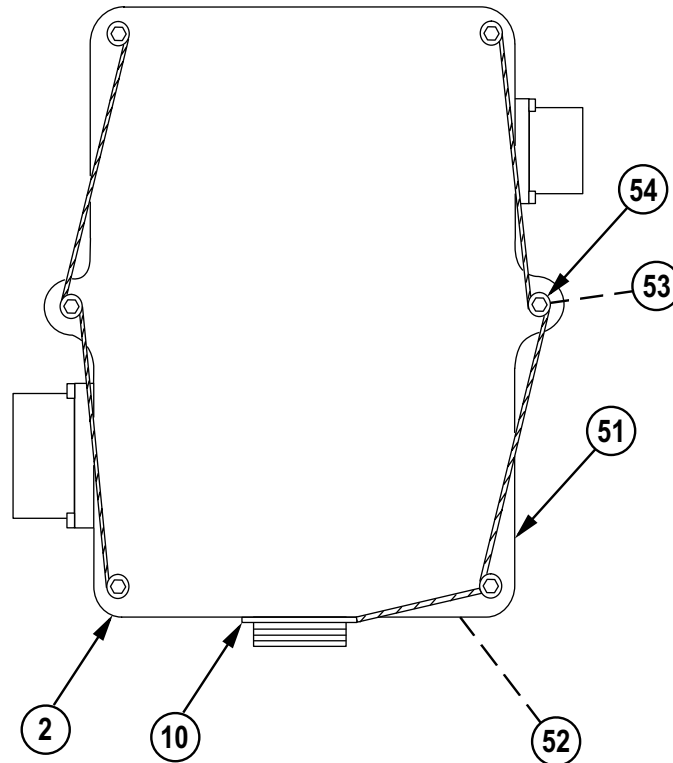

- 14 Tuck all wires inside terminal box (2), ensuring clearance for installation of access cover (51).
- 15 Install gasket (52). Align six holes in access cover (51) with six threaded holes in terminal box (2) and install six new lockwashers (53) and six externally relieved bolts (54).
- 16 Install lock wire (item 37, appx B) to secure three externally relieved bolts (54) together on each side of access cover (51). Include nut (10) with one of the sets of bolts.

2-39. RAM HYDRAULIC PUMPS—MAINTENANCE INSTRUCTIONS

THIS TASK COVERS:

- | | | |
|---------------|----------------|----------------------|
| a. Deleted | b. Disassembly | c. Inspection/repair |
| d. Reassembly | e. Deleted | |

INITIAL SETUP

Tools and Special Tools

- Artillery and turret mechanic's ordnance tool kit (SC 5180-95-CL-A43)
- Fabricated tubular spanner wrench (figure C-2)

Materials/Parts

- Cotter pin (2) (MS24665-151)
- Oil (hydraulic fluid) (item 14, appx B)
- Preformed packing (2) (MS28775-006)
- Preformed packing (MS28775-114)
- Preformed packing (MS28775-115)
- Preformed packing (MS28775-120)
- Retainer packing (2) (MS28774-011)
- Retainer packing (MS28774-114)
- Retainer packing (2) (MS28774-115)
- Retainer packing (MS28774-120)

References

- TM 9-1025-211-20&P
- TM 9-1025-211-34P

Equipment Conditions

- Ram hydraulic pumps removed (TM 9-1025-211-20&P)

NOTE

All data on page 2-267 deleted.

2-39. RAM HYDRAULIC PUMPS—MAINTENANCE INSTRUCTIONS (cont)

DISASSEMBLY

- 1 Remove two cotter pins (1).
- 2 Remove two pins (2), handle (3), and two links (4).

NOTE

Bushing is removed for replacement of authorized parts only.

- 3 Remove bushing (5) from handle (3).

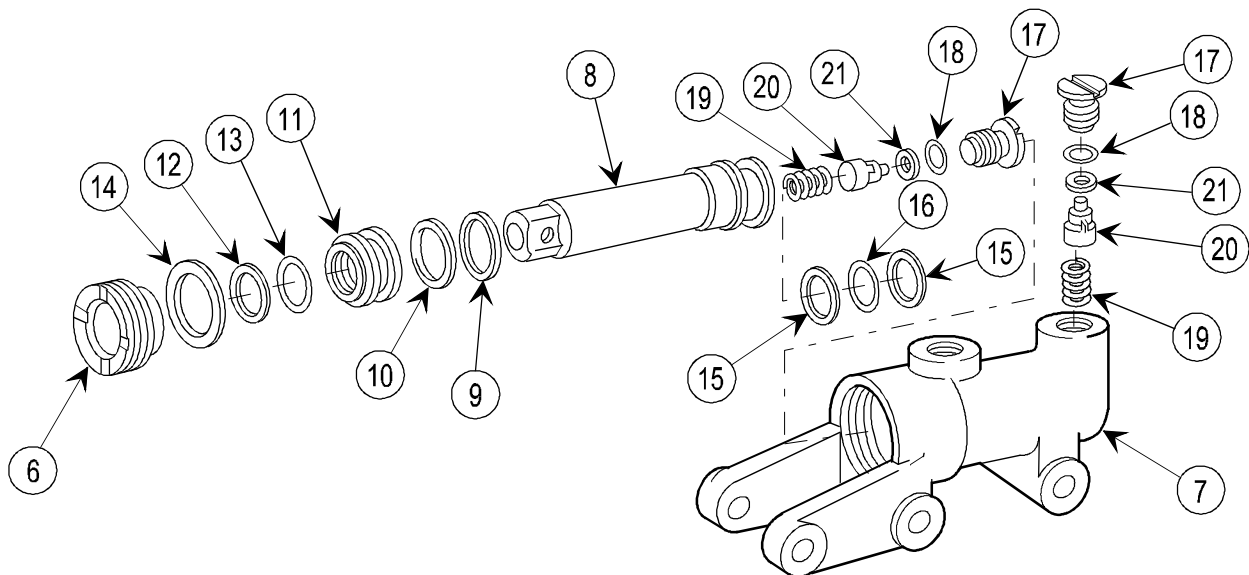
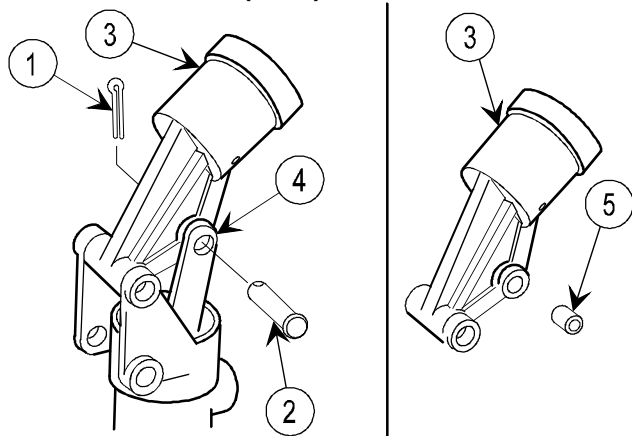

- 4 Remove linear cap (6) from pump body (7) using fabricated spanner wrench.
- 5 Remove piston rod (8), preformed packing (9), retainer packing (10), linear piston (11), preformed packing (12), and retainer packing (13) as an assembly.
- 6 Remove retainer (14).
- 7 Remove linear piston (11) from piston rod (8).
- 8 Remove retainer packing (13), preformed packing (12), retainer packing (10), and preformed packing (9) from linear piston (11).
- 9 Remove two retainer packings (15) and preformed packing (16) from piston rod (8).
- 10 Remove threaded screws (17), with preformed packings (18), springs (19), check valves (20), and preformed packings (21) from piston rod (8) and pump body (7).
- 11 Remove preformed packings (18) from two threaded screws (17).
- 12 Remove preformed packings (21) from two check valves (20).

INSPECTION/REPAIR

- 1 Check for broken, damaged, or missing parts.
- 2 Repair is by replacement of authorized parts (TM 9-1025-211-34P).
- 3 Replace ram hydraulic pump if oil leaks from piston or if the housing is cracked or broken.

REASSEMBLY

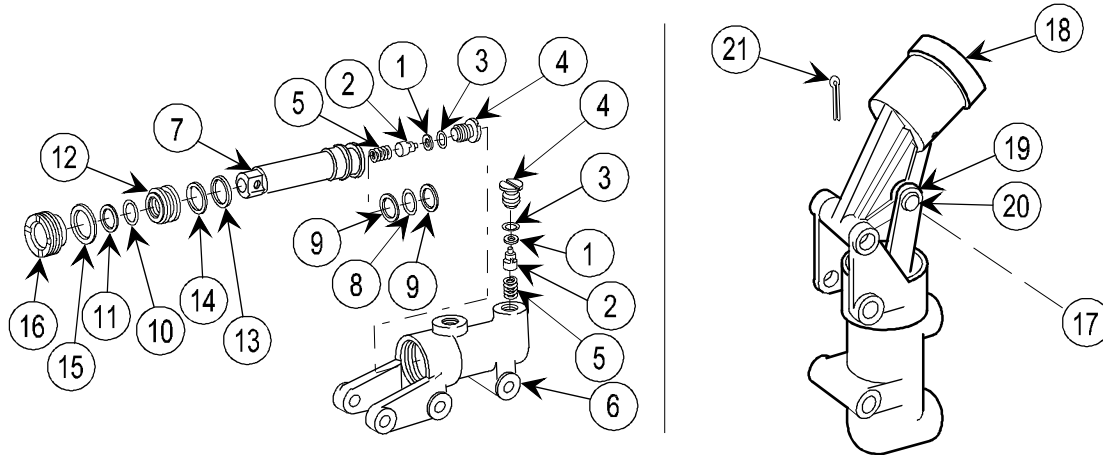

NOTE

Lubricate preformed packing with oil (hydraulic fluid) prior to installing.

- 1 Assemble preformed packings (1) on two check valves (2).
- 2 Assemble preformed packings (3) on two threaded screws (4).
- 3 Install springs (5), check valves (2), and threaded screws (4) in pump body (6) and piston rod (7).
- 4 Assemble preformed packing (8) and two retainer packings (9) on piston rod (7).
- 5 Assemble preformed packing (10) and retainer packing (11) in internal groove of linear piston (12).
- 6 Assemble preformed packing (13) and packing retainer (14) on external groove of linear piston (12).
- 7 Assemble linear piston (12) and retainer (15) on piston rod (7).
- 8 Install piston rod (7), preformed packing (13), retainer packing (14), linear piston (12), preformed packing (10), and retainer packing (11) as an assembly into pump body (6).
- 9 Install linear cap (16) on assembled piston rod (7) and tighten into pump body (6) with fabricated spanner wrench.
- 10 Install bushing (17) in handle (18).
- 11 Install two links (19), handle (18), and two pins (20).
- 12 Install two cotter pins (21).

NOTE

All data on page 2-270 deleted.

2-40. MANIFOLD ASSEMBLY AND HYDRAULIC PARTS—MAINTENANCE INSTRUCTIONS

THIS TASK COVERS:

- | | | |
|---------------|-----------------|----------------------|
| a. Removal | b. Disassembly | c. Inspection/repair |
| d. Reassembly | e. Installation | f. Service |

INITIAL SETUP

Tools and Special Tools

- Artillery and turret mechanic's ordnance tool kit (SC 5180-95-CL-A12)
- Mechanical screw jack (GGG-J-51)

Materials/Parts

- Abrasive cloth (item 8, appx B)
- Adhesive (item 2, appx B)
- Cleaning compound (item 7, appx B)
- Gasket (12008825)
- Gasket (12008826)
- Lock wire (item 34, appx B)
- Oil (hydraulic fluid) (item 14, appx B)
- Preformed packing (2) (MS28775-014)
- Preformed packing (3) (MS28775-016)
- Preformed packing (8) (MS28775-111)
- Preformed packing (4) (MS28778-6)
- Preformed packing (13) (MS28778-8)
- Preformed packing (5) (MS28778-10)
- Preformed packing (MS28778-12)
- Preformed packing (3) (12008815)
- Sealing compound (item 26, appx B)
- Tape (item 32, appx B)
- Wiping rag (item 22, appx B)

References

- TM 9-1025-211-10
- TM 9-1025-211-20&P
- TM 9-1025-211-34P

Equipment Conditions

- Wheels down and locked into position (TM 9-1025-211-10)
- Ram hydraulic pumps and attaching parts removed (TM 9-1205-211-20&P)
- Blocking available
- 2-242 Both access covers on top carriage assembly removed for removal of hose assemblies
- 2-290 Speed shift baseplate removed
- 2-258 Bottom carriage assembly access covers removed for removal of hose assemblies and draining of fluid from manifold assembly

2-40. MANIFOLD ASSEMBLY AND HYDRAULIC PARTS—MAINTENANCE INSTRUCTIONS (cont)

REMOVAL

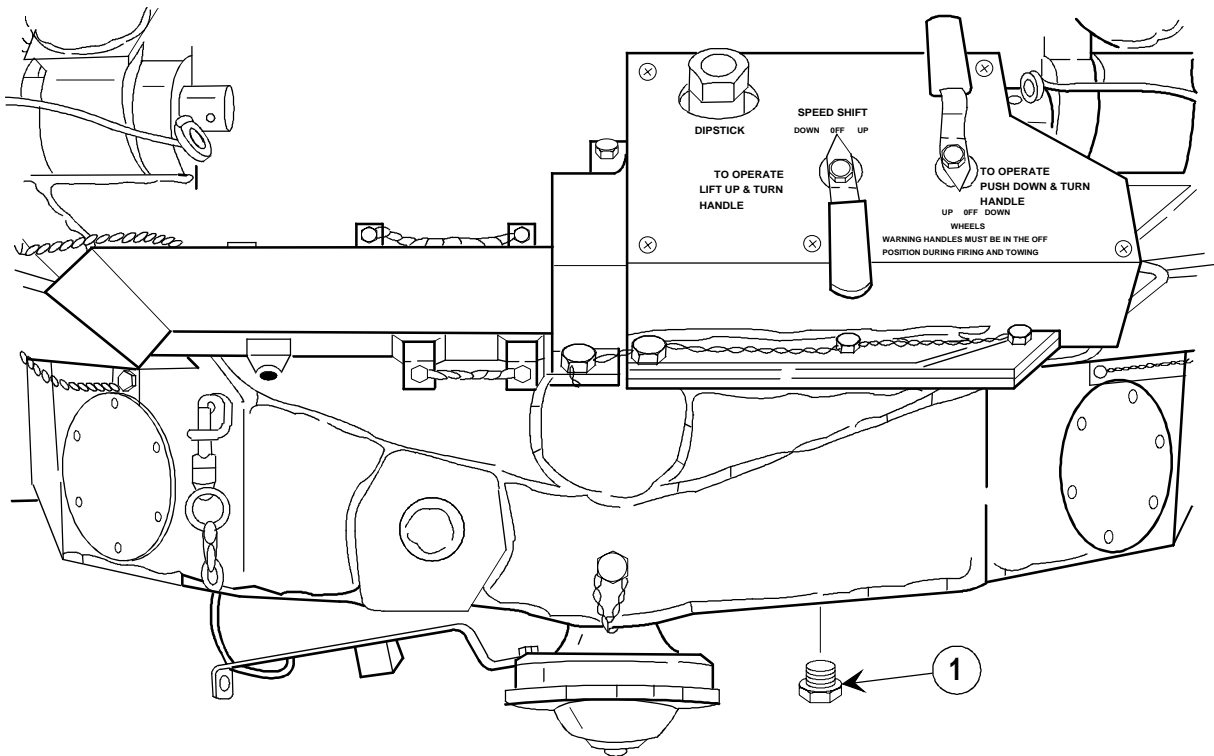

NOTE

SPEED SHIFT and WHEELS handles must be in OFF position to ensure pressure is off hydraulic lines.

Hydraulic system holds approximately 11 qt (10 liters) of oil. Place suitable container under bottom of manifold assembly before removing drain plug.

- 1 Remove plug (1) and let oil drain; reinstall plug (1).
- 2 Deleted.
- 3 Deleted.
- 4 Deleted.

NOTE

All data on pages 2-273 and 2-274 deleted.

- 17 Deleted.
- 18 Deleted.
- 19 Deleted.
- 20 Deleted.

- 21 Remove five bolts (47) and five lockwashers (48).

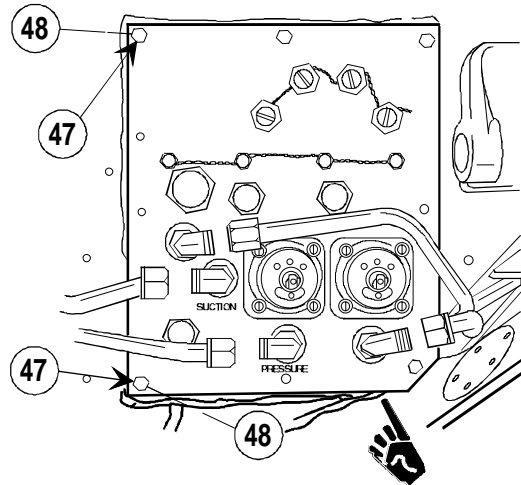

- 22 Lift manifold assembly (36) approximately 4 in. (10 cm), and block with wooden blocks (49).
- 23 Disconnect four hose assemblies (50, 51, 52, and 53). Check for presence of marker bands, and cover open ends with clean wiping rags.
- 24 Lift manifold assembly (36) out of bottom carriage assembly (54), and remove wooden blocks (49).
- 25 Remove gasket (55) from bottom carriage assembly (54).

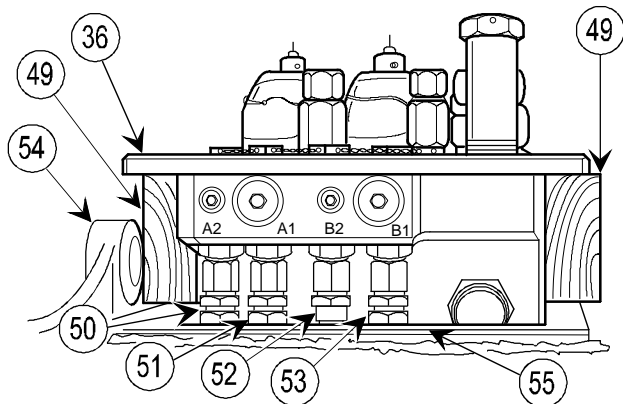

2-40. MANIFOLD ASSEMBLY AND HYDRAULIC PARTS—MAINTENANCE INSTRUCTIONS (cont)

REMOVAL (cont)

NOTE

Steps 26 thru 31 do not apply to repair of the manifold assembly. These steps are procedures for removal of hydraulic lines and related parts.

- 26 Remove two nuts (56) on two elbows (57). Remove elbows (57).

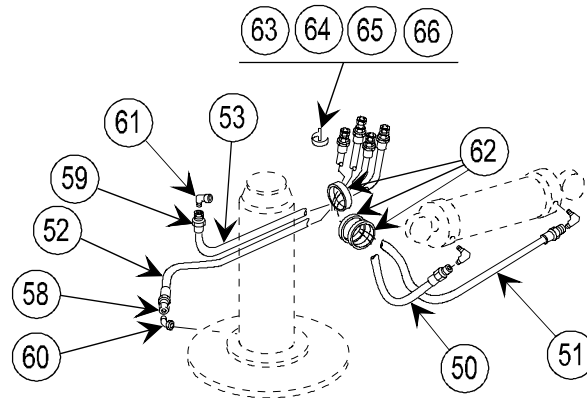
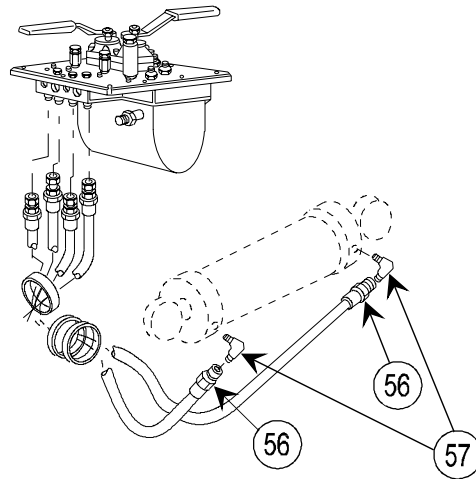

- 27 Remove two hose assemblies (50 and 51).
- 28 Remove two nuts (58 and 59) and two elbows (60 and 61).
- 29 Remove two hose assemblies (52 and 53).
- 30 Remove three preformed packings (62).

NOTE

Remove marker bands only if new hose assemblies are to be installed.

- 31 Remove four marker bands (63, 64, 65, and 66).

DISASSEMBLY

NOTE

For clarity, manifold block will only show parts being called out.

- 1 Remove lock wire (1) and eight bolts (2).
- 2 Remove two selector valves (3 and 4) and eight preformed packings (5).

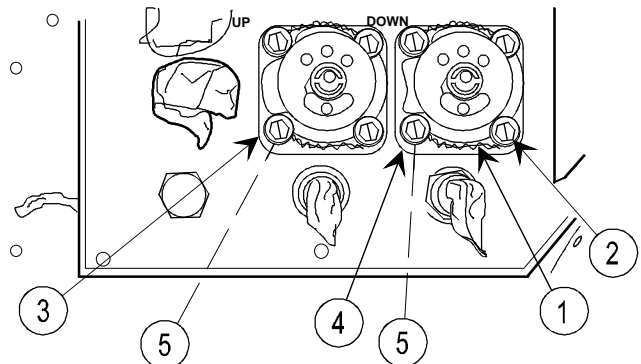

- 3 Remove lock wire, four bolts (6), and four lockwashers (7).
- 4 Remove dipstick (8), filter (9), and preformed packing (10).
- 5 Remove three valve assemblies (11), three preformed packings (12), three preformed packings (13), and three packing retainers (14).
- 6 Remove two tube nipples (15) and two preformed packings (16).
- 7 Remove safety valve (17), preformed packings (18 and 19), and packing retainer (20).

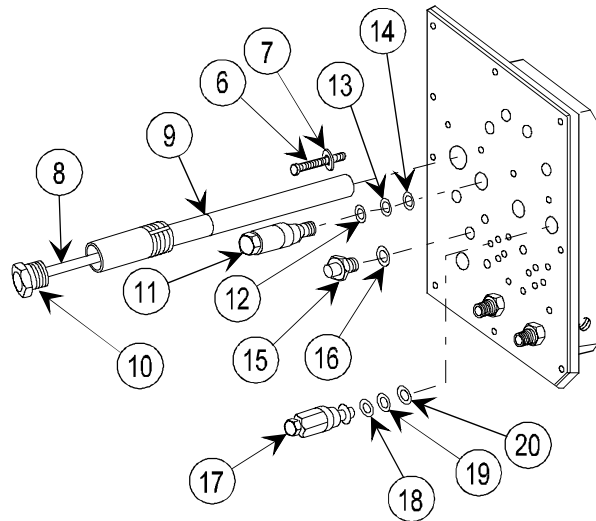

- 8 Remove two lock wires (21) from manifold assembly (22).
- 9 Remove four plugs (23) and four preformed packings (24).

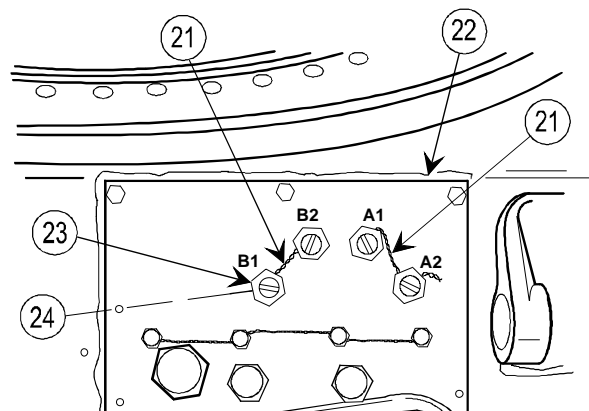

- 10 Remove lock wire, four bolts (25), and four lockwashers (26).
- 11 Using screwdriver, carefully separate block (27) and reservoir (28).
- 12 Remove gasket (29).
- 13 Remove plug (30) and preformed packing (31).
- 14 Remove breather vent (32) and preformed packing (33).

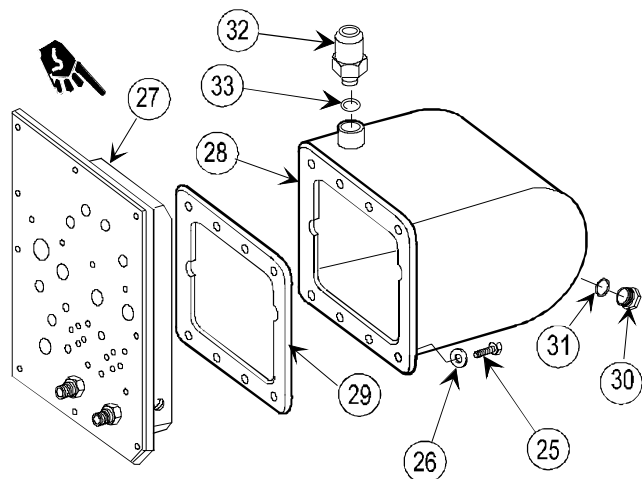

2-40. MANIFOLD ASSEMBLY AND HYDRAULIC PARTS—MAINTENANCE INSTRUCTIONS (cont)

DISASSEMBLY (cont)

NOTE

Parts attached to nuts (34 and 35) are not authorized for field replacement. However, they can be removed by field to replace field repair parts.

- 15 Disconnect four nuts (34) from four tube nipples (36) and remove four tubes with attached parts.
- 16 Disconnect two nuts (35) from two check valves (37), and remove two tubes with attached parts.
- 17 Remove four tube nipples (36) and four preformed packings (38).

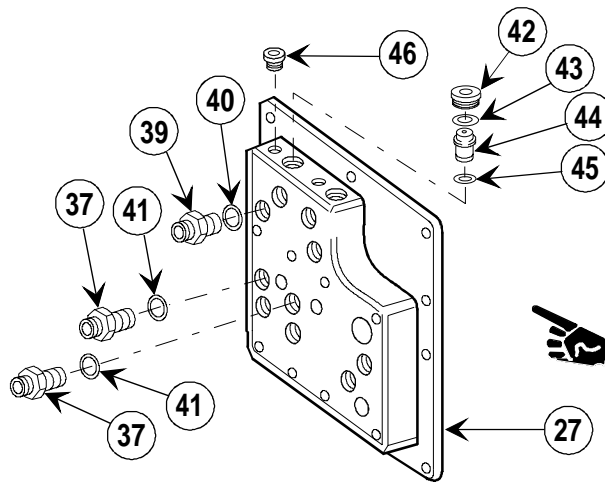
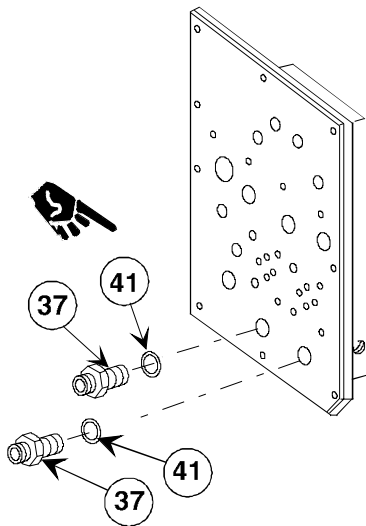
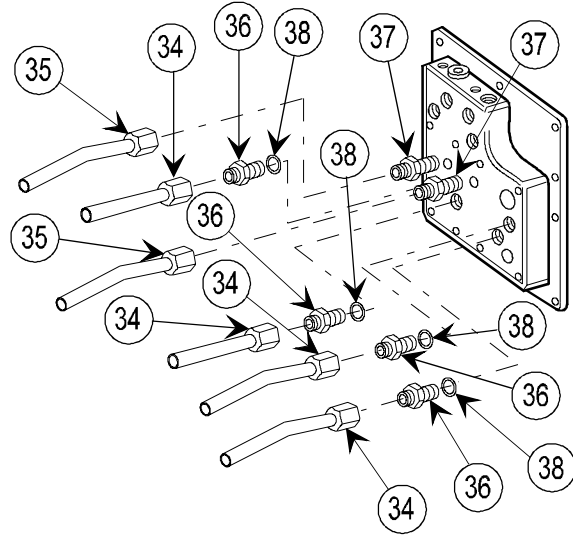

- 18 Remove four tube nipples (39) and four preformed packings (40).
- 19 Remove four check valves (37) and four preformed packings (41).
- 20 Remove two plugs (42), two preformed packings (43), two valve assemblies (44), and two preformed packings (45).
- 21 Remove five pipe plugs (46) from block (27).

INSPECTION/REPAIR

- 1 Check for broken, damaged, or missing parts.
- 2 Repair is by replacement of authorized parts (TM 9-1025-211-34P).
- 3 Replace manifold assembly if the block or reservoir is cracked, damaged, or broken beyond repair.

REASSEMBLY

NOTE

Torque all tube nipples, plugs, check valves, vents, and valve assemblies to 4 to 6 ft-lb (5 to 8 N-m).

- 1 Install two new preformed packings (1), two valve assemblies (2), two new preformed packings (3), and two plugs (4).
- 2 Wrap threads of five pipe plugs (5) with tape and install in block (6).

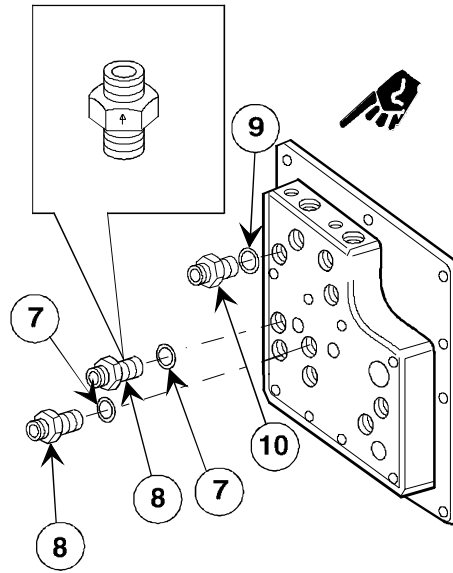
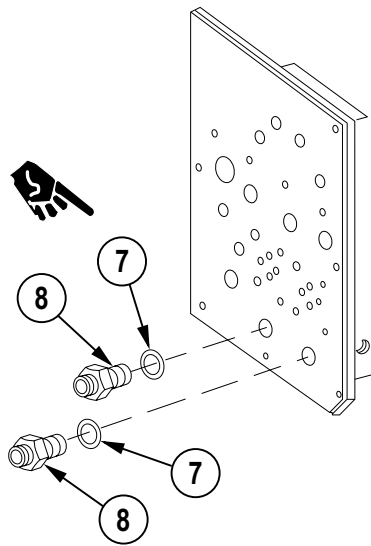
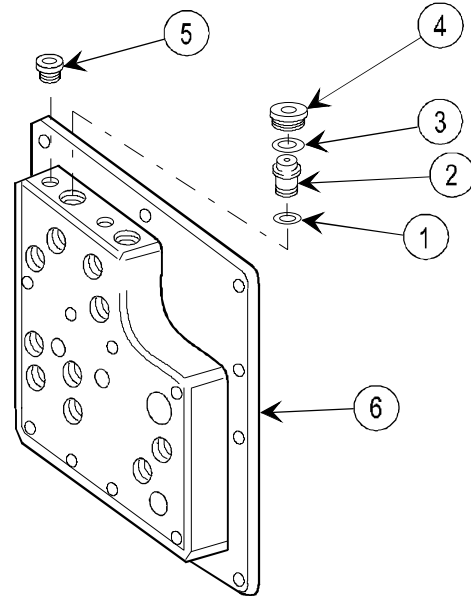

NOTE

Install check valves with arrow pointing toward block.

- 3 Install four new preformed packings (7) and four check valves (8).
- 4 Install four new preformed packings (9) and four tube nipples (10).

2-40. MANIFOLD ASSEMBLY AND HYDRAULIC PARTS—MAINTENANCE INSTRUCTIONS (cont)

REASSEMBLY (cont)

- 5 Install four new preformed packings (11) and four tube nipples (12).
- 6 Connect two nuts (13) on two check valves (8), installing two tubes with attached parts.
- 7 Connect four nuts (14) on four tube nipples (12), installing four tubes with attached parts.

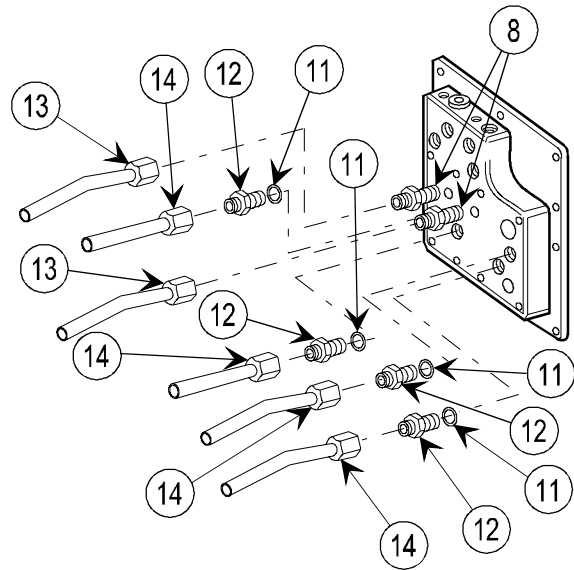

- 8 Install new preformed packing (15) and breather vent (16).
- 9 Install new preformed packing (17) and plug (18).
- 10 Scrape block (6) and reservoir (19) around area where gasket (20) is to be installed, and clean with abrasive cloth and cleaning compound.
- 11 Apply sealing compound on one side of new gasket (20), and install on reservoir (19).

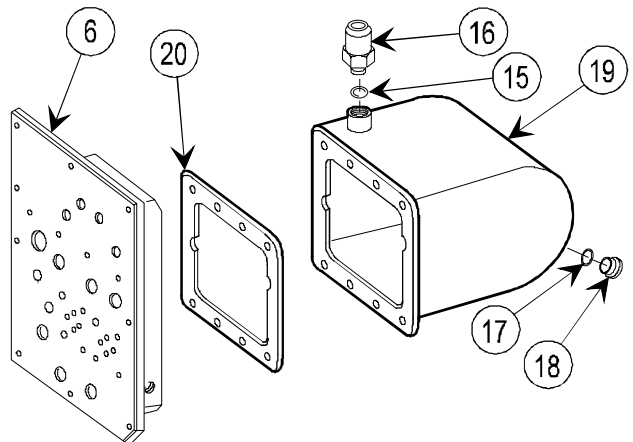

- 12 Apply sealing compound on other side of new gasket (20).
- 13 Install block (6) on reservoir (19).
- 14 Install four lockwashers (21) and four bolts (22).
- 15 Install block (6), four new preformed packings (23), and four plugs (24), but do not tighten.

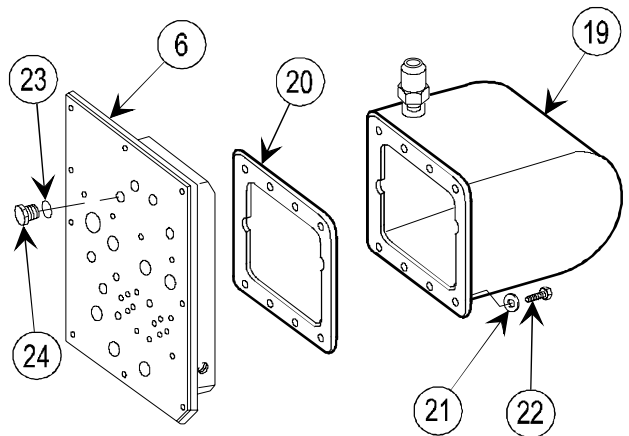

- 16 Install four lockwashers (25) and four bolts (26). Torque bolts (26) to 8 to 10 ft-lb (11 to 13 N-m), and install lock wire.
- 17 Torque four bolts (22) 6 to 8 ft-lb (8 to 11 N-m), and install lock wire.

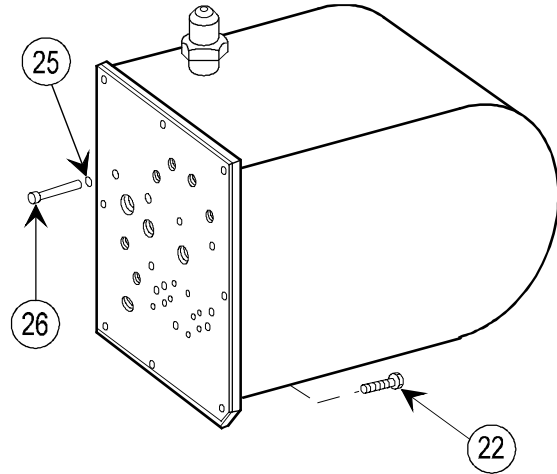

- 18 Install two new preformed packings (27) and two tube nipples (28).
- 19 Install three packing retainers (29), three new preformed packings (30), three new preformed packings (31), and three valve assemblies (32).
- 20 Install new preformed packing (33), filter (34), and dipstick (35).
- 21 Install new packing retainer (36), new preformed packings (37 and 38), and safety valve (39).

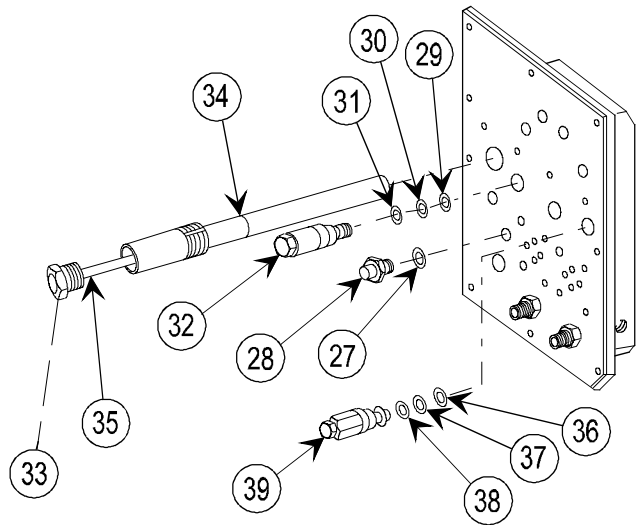

- 22 Install eight new preformed packings (40) and two selector valves (41 and 42).
- 23 Install eight bolts (43). Torque eight bolts (43) to 25 to 30 ft-lb (34 to 40 N-m), and install lock wire.

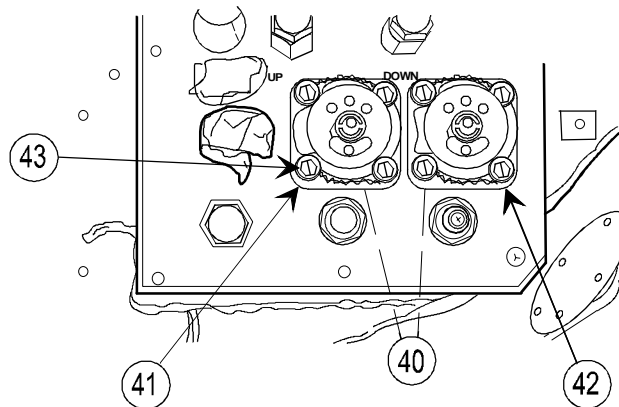

2-40. MANIFOLD ASSEMBLY AND HYDRAULIC PARTS—MAINTENANCE INSTRUCTIONS (cont)

INSTALLATION

NOTE

Steps 1 thru 6 do not apply to the repair of the manifold assembly.

If new hose assemblies are installed, place marker bands on new hose assemblies.

- 1 Install four marker bands (1, 2, 3, and 4) to match with four hose assemblies (5, 6, 7, and 8).

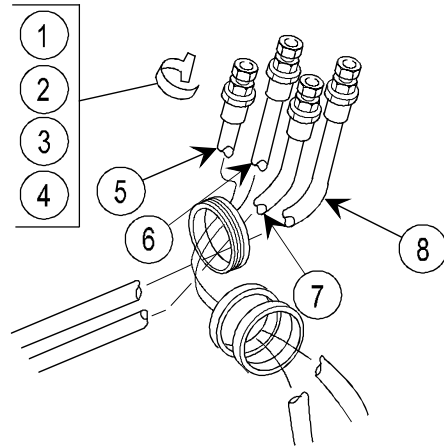

- 2 Apply adhesive to three new preformed packings (9) and install into bottom carriage assembly.

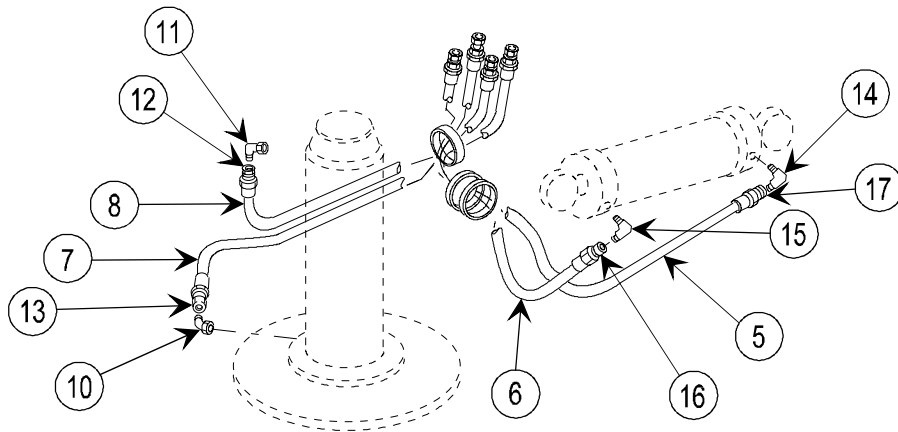
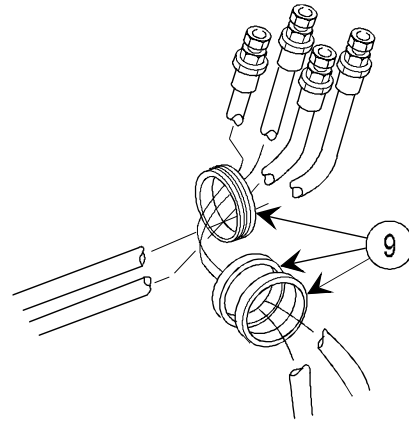

- 3 Install two elbows (10 and 11) on speed shift assembly.
- 4 Install two hose assemblies (7 and 8) at one end by connecting two nuts (12 and 13) on two tube elbows (10 and 11).
- 5 Install two elbows (14 and 15) on actuator cylinder assembly.
- 6 Install two hose assemblies (5 and 6) at one end by connecting two nuts (16 and 17) on two elbows (14 and 15).

- 7 Install new gasket (18) on manifold assembly (19).
- 8 Install manifold assembly (19) on bottom carriage assembly (20), and block with wooden blocks (21).
- 9 Remove rags and carefully connect four hose assemblies (5, 6, 7, and 8) referring to marker bands for proper installation.
- 10 Remove wooden blocks (21), and lower manifold assembly (19) to bottom carriage assembly (20).

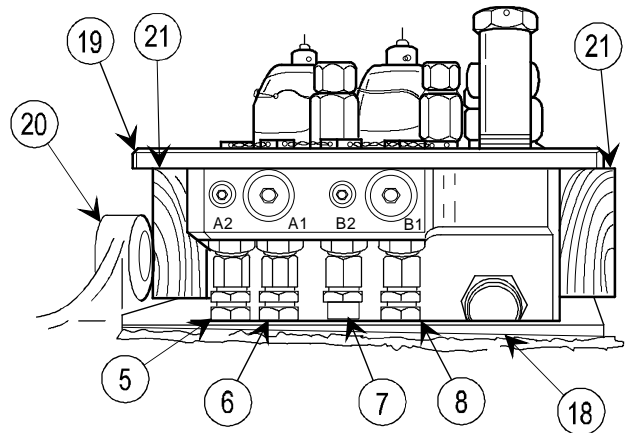

- 11 Install five lockwashers (22) and five bolts (23) and torque bolts (23) to 6 + 2 ft-lb (8 + 3 N-m).
- 12 Deleted.

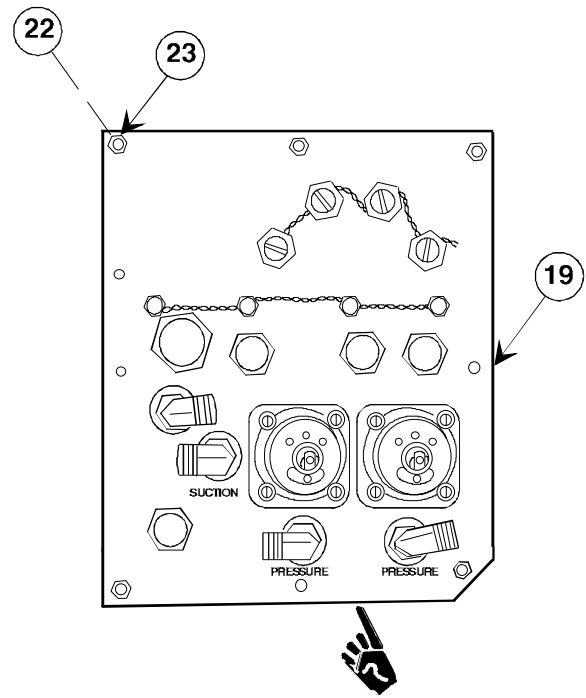

- 13 Deleted.

NOTE

All data on pages 2-284 and 2-285 deleted.

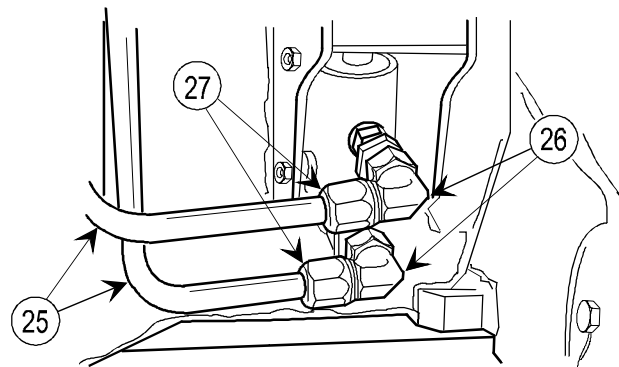

2-40. MANIFOLD ASSEMBLY AND HYDRAULIC PARTS—MAINTENANCE INSTRUCTIONS (cont)

INSTALLATION (cont)

- 28** Install SPEED SHIFT handle (40) with one nut (39).
- 29** Place SPEED SHIFT handle (40) in UP position, actuate hydraulic pump until oil (hydraulic fluid) flows out of port B2 around plug (37), and tighten plug (37).
- 30** Place SPEED SHIFT handle (40) in DOWN position, actuate hydraulic pump until oil (hydraulic fluid) flows out of port B1 around plug (37), and tighten plug (37).
- 31** Place SPEED SHIFT handle (40) in OFF position.
- 32** Remove nut (39) and SPEED SHIFT handle (40).
- 33** Install two lock wires.

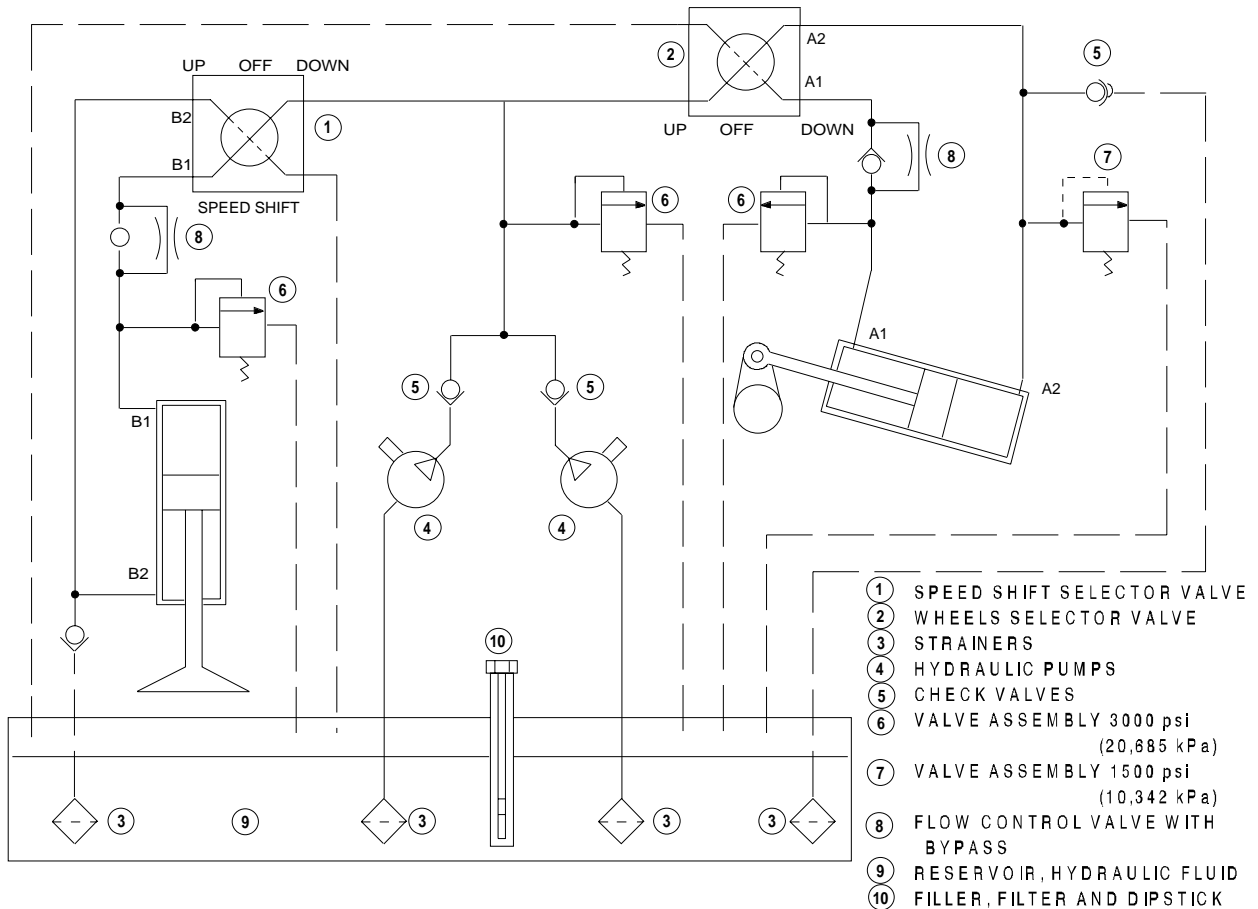
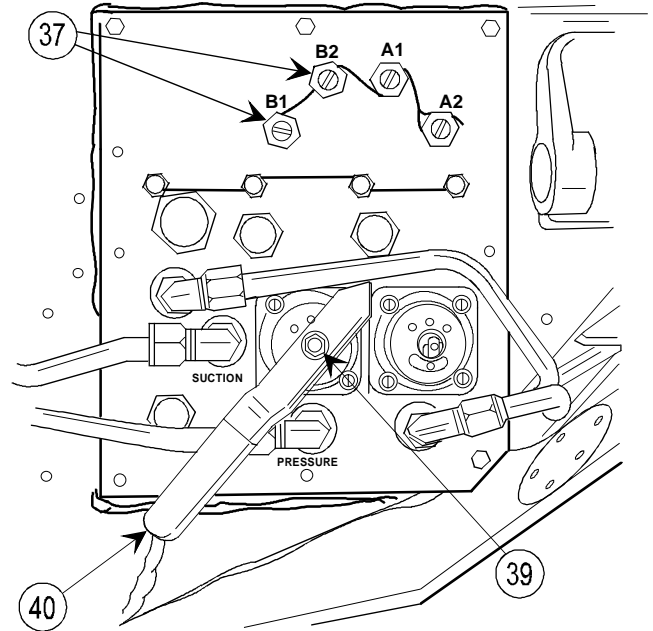

NOTE

All data on pages 2-287 and 2-288 deleted.

NOTE

The fabricated gauge can be used to check part numbers 12009321 (valve assembly 1500 psi) and 12008802 (valve assembly 3000 psi). These are relief valves for the speed shift and wheels of manifold 12008800. Checking of ports B1, B2, A1, and A2 can be accomplished by attaching the fabricated gauge to these ports.

- 34** Attach fabricated gauge (Figure C-21, appx C) to port B1. Place SPEED SHIFT handle (40) to DOWN position to activate port B1. The fabricated gauge should read almost 3000 psi before releasing pressure.
- 35** Attach fabricated gauge (Figure C-21, appx C) to port B2. Place SPEED SHIFT handle (40) to UP position to activate port B2. The fabricated gauge should read almost 3000 psi before releasing pressure.
- 36** Attach fabricated gauge (Figure C-21, appx C) to port A1. Place WHEELS handle to DOWN position to activate port A1. The fabricated gauge should read almost 1500 psi before releasing pressure.
- 37** Attach fabricated gauge (Figure C-21, appx C) to port A2. Place WHEELS handle to UP position to activate port A2. The fabricated gauge should read almost 1500 psi before releasing pressure.

SERVICE

- 1 Place howitzer on available blocking.
- 2 Remove cover plate from bottom of carriage.
- 3 Remove drain plug (1) and drain oil (hydraulic fluid) from manifold assembly (2).

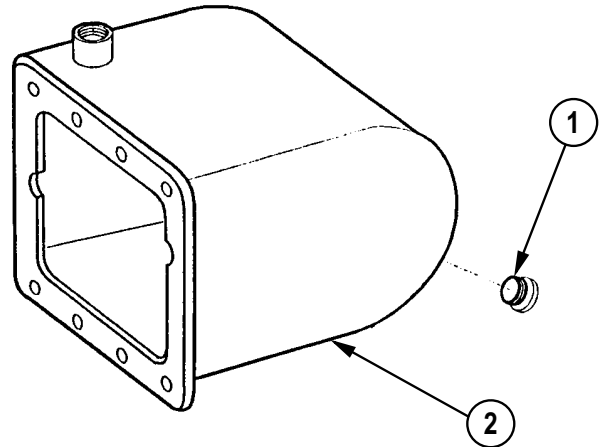

NOTE

The hydraulic system holds approximately 11 quarts (10 liters) of oil (hydraulic fluid).

- 4 Exercise RAM pumps to remove oil (hydraulic fluid). Actuate WHEELS and SPEED SHIFT handles (3) and (4).
- 5 Replace drain plug (1) and add oil (hydraulic fluid).
- 6 Exercise WHEELS handle (3) up and down using the RAM pumps.

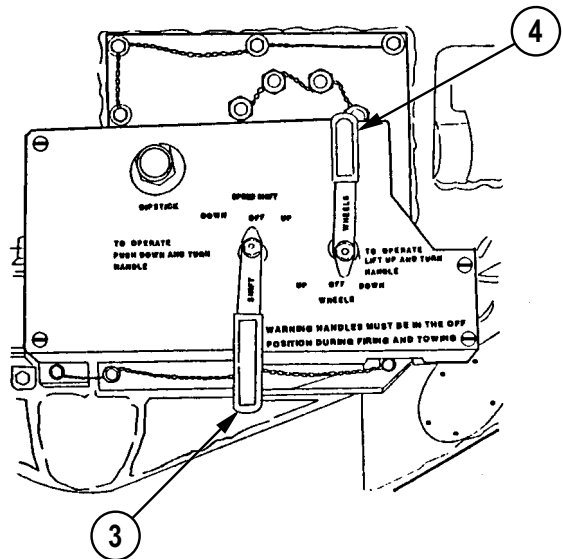

- 7 Check level of oil (hydraulic fluid) with dipstick (5) and add as required.
- 8 Exercise SPEED SHIFT handle up and down using the RAM pumps.
- 9 Deleted.
- 10 Deleted.
- 11 Deleted.
- 12 Remove blocking.

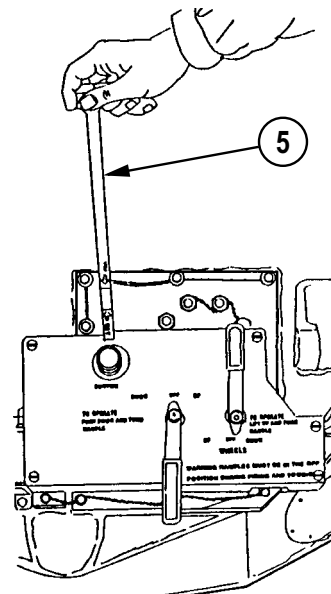

2-41. SPEED SHIFT CYLINDER ASSEMBLY—MAINTENANCE INSTRUCTIONS

THIS TASK COVERS:

- | | | |
|---------------|-----------------|----------------------|
| a. Removal | b. Disassembly | c. Inspection/repair |
| d. Reassembly | e. Installation | |

INITIAL SETUP

Tools and Special Tools

Artillery and turret mechanic's ordnance tool kit (SC 5180-95-CL-A12)

Materials/Parts

Gasket (12008273)
Gasket (12008457)
Oil (hydraulic fluid) (item 14, appx B)
Preformed packing (2) (MS28778-8)

NOTE

Disposal of hydraulic fluid must be in accordance with local, state, and federal regulation.

Personnel Required: 2

References

TM 9-1025-211-10
TM 9-1025-211-20&P
TM 9-1025-211-34P

Equipment Conditions

Weapon elevated to approximately 600 mils (TM 9-1025-211-10)
Weapon supported on blocks so that wheels are 5 in. (13 cm) off ground in towed position
WHEELS handle in OFF position (TM 9-1025-211-10)
2-258 Access covers removed from bottom side of bottom carriage for access to hoses and fittings

REMOVAL

- 1 Remove 14 capscrews (1) and 14 lockwashers (2).

NOTE

Standoff (4) and second gasket (5) apply to modified howitzers only.

- 2 Remove access cover (3), two gaskets (5) and standoff (4).

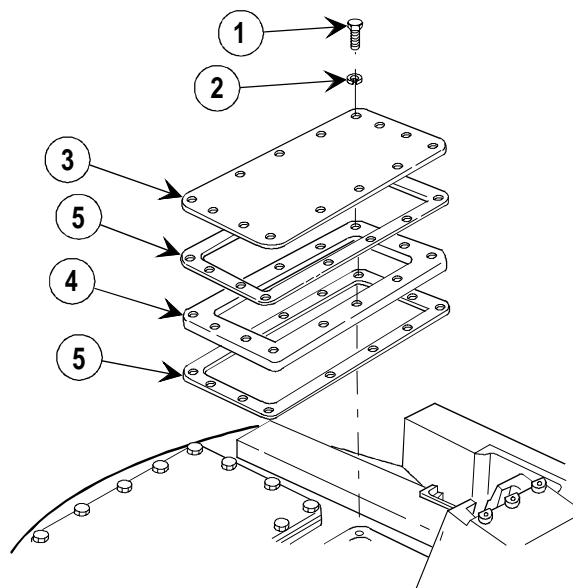

- Remove eight bolts (6) and linear baseplate (7).

NOTE

Socket ball seat (8) is used in a limited number of howitzers.

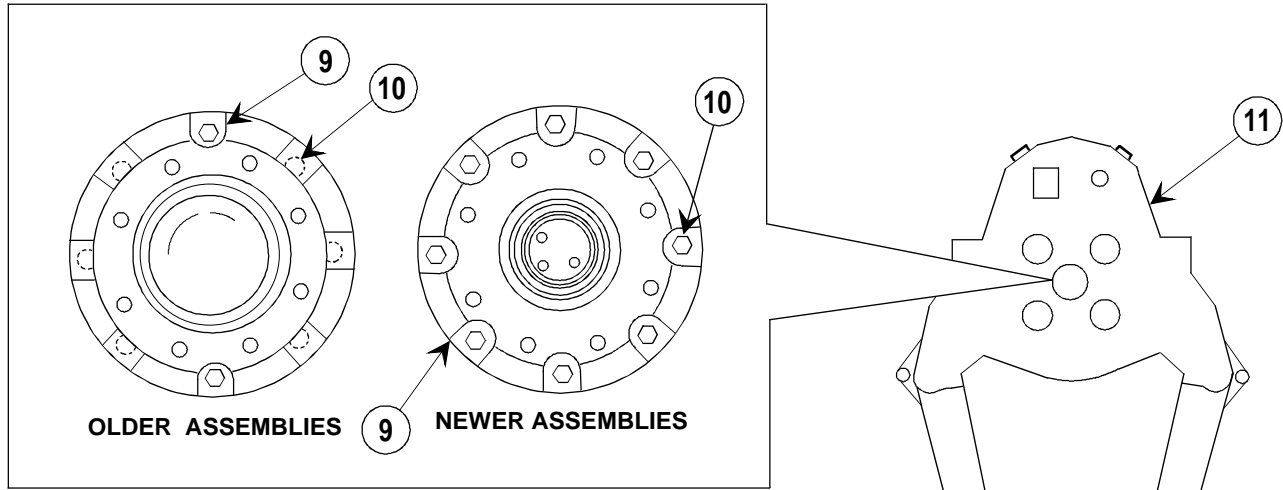
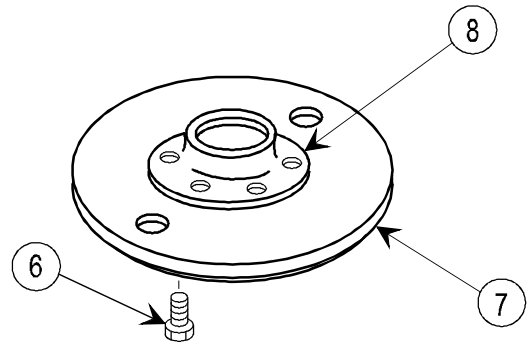

NOTE

Notches (9) must be aligned with heads of bolts (10) for removal.

- Remove six bolts (10), leaving two bolts (10) on opposite sides.
- Loosen remaining two bolts (10).

NOTE

If speed shift cylinder assembly does not slip down from bottom carriage assembly (11) when bolts are loosened, place a wood block on top of the cylinder and tap it free with a hammer.

- Ensure SPEED SHIFT handle (12) is in OFF position.

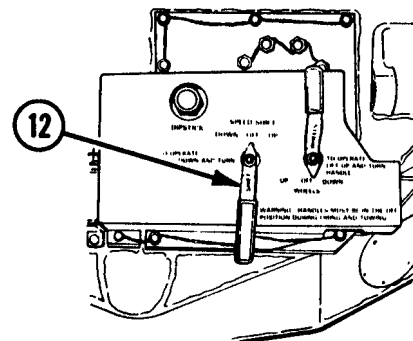

2-41. SPEED SHIFT CYLINDER ASSEMBLY—MAINTENANCE INSTRUCTIONS (cont)

REMOVAL (cont)

NOTE

Oil (hydraulic fluid) will drain from speed shift cylinder assembly when hoses and fittings are removed.

- 7 Unscrew hose assembly (13) from tube elbow (14).
- 8 Remove tube elbow (14).
- 9 Remove tube nipple (15) and preformed packing (16)
- 10 Unscrew hose assembly (17) from tube elbow (18).
- 11 Remove tube elbow (18).
- 12 Remove tube nipple (19) and preformed packing (20)

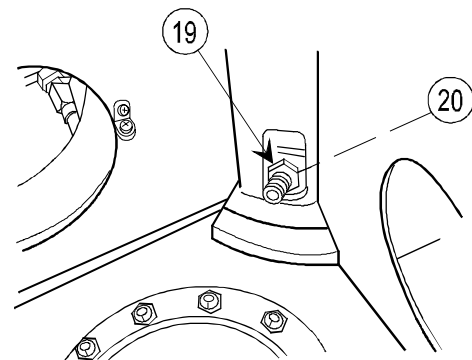
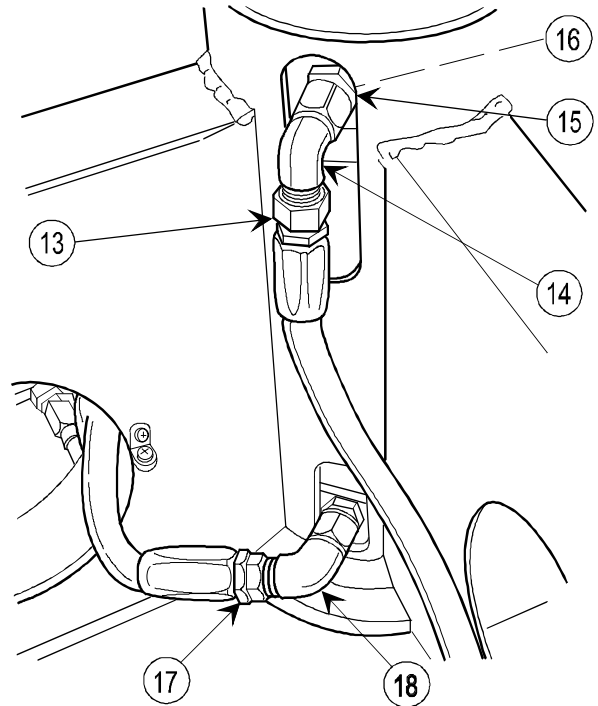

NOTE

Two personnel are required for step 13.

- 13 Support speed shift cylinder assembly (21) while removing last two bolts (10) and remove speed shift cylinder assembly.
- 14 Remove gasket (22).

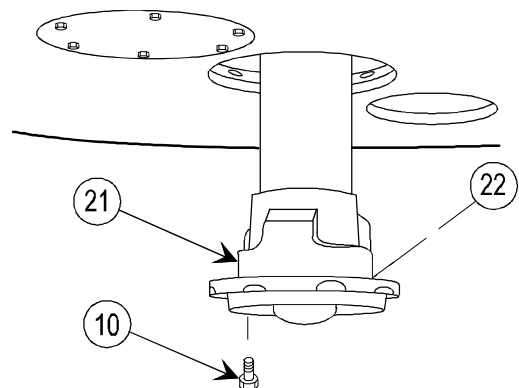

DISASSEMBLY

NOTE

There are two different speed shift cylinder assembly designs. Steps 1 and 2 apply to P/N 12009030 and steps 3 thru 8 apply to P/N 9324735.

Speed shift cylinder assembly need not be removed from bottom carriage assembly for steps 1 thru 8.

- 1 Remove setscrew (1) and plug (2).
- 2 Remove bushing clamps (3) and bushing (4) from rod (5) and separate.

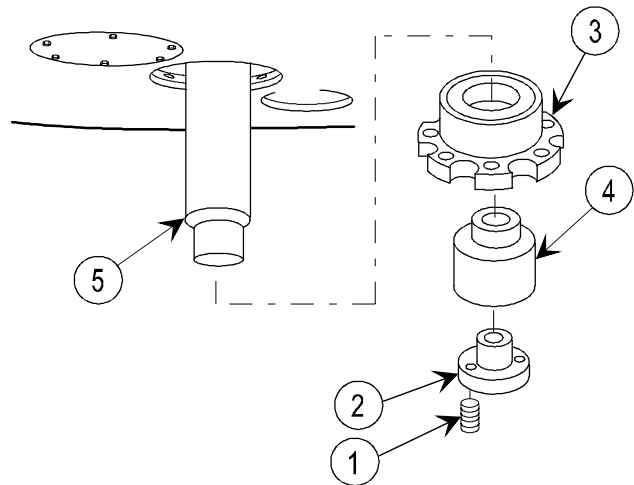

NOTE

Rod assembly will have to be extended to perform the following steps.

- 3 Extend rod (5) to allow removal of pins (6).
- 4 Remove socket ball seat (7) from linear baseplate (8).
- 5 Drive out two pins (6).
- 6 Unscrew socket ball (9) and remove.
- 7 Remove ball locking ring (10).
- 8 Remove expansion plug (11).

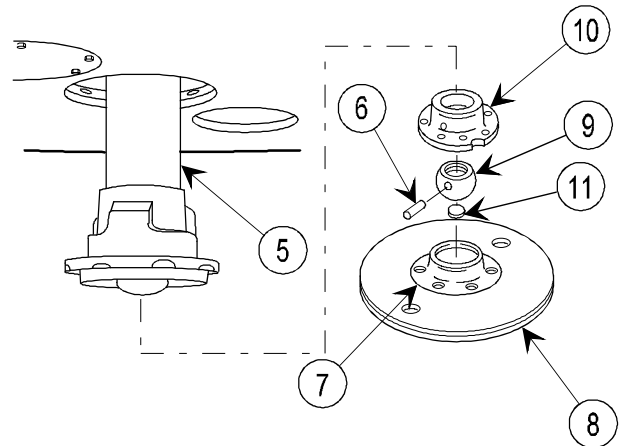

INSPECTION/REPAIR

- 1 Check for broken, damaged, or missing parts.
- 2 Repair is by replacement of authorized parts (TM 9-1025-211-34P).
- 3 Replace speed shift cylinder assembly if it is cracked or broken, or if rod assembly will not move up or down.

2-41. SPEED SHIFT CYLINDER ASSEMBLY—MAINTENANCE INSTRUCTIONS (cont)

REASSEMBLY

- 1 Install expansion plug (1).
- 2 Place ball locking ring (2) into position.
- 3 Screw socket ball (3) onto rod assembly (4).
- 4 Install two pins (5).
- 5 Position socket ball seat (6) onto linear baseplate (7).
- 6 Assemble bushing (8) and bushing clamp (9) and install on rod (4).
- 7 Install plug (10) and setscrew (11).

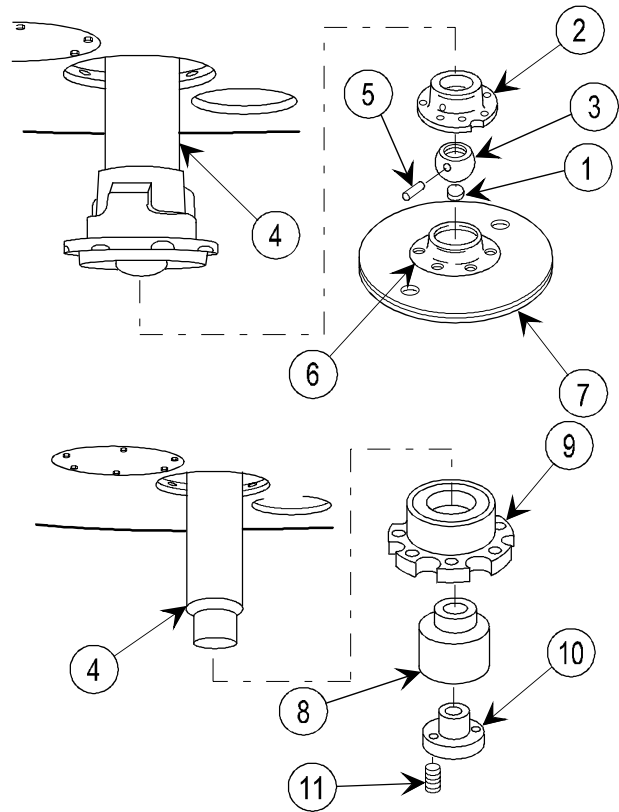

INSTALLATION

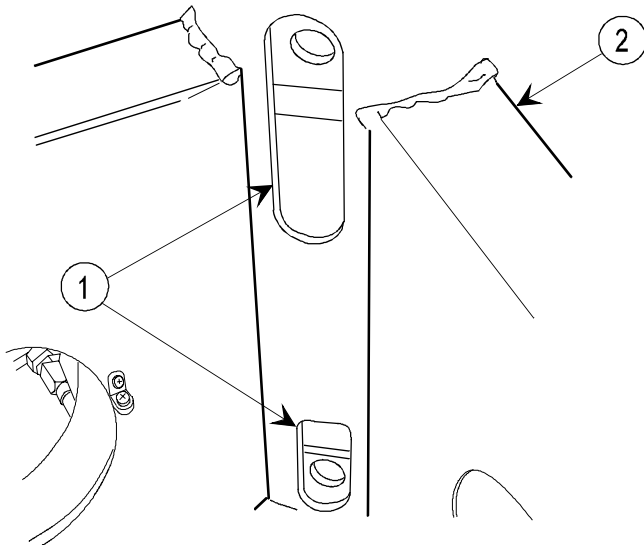

NOTE

Make sure openings on speed shift cylinder assembly are lined up with slots (1) in bottom carriage assembly (2).

- 1 Install new gasket (3).

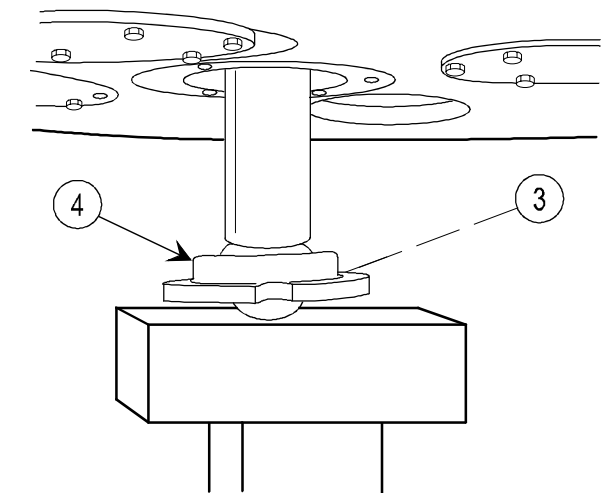

- 2 Install speed shift cylinder assembly (4) into opening of bottom carriage assembly, and support with suitable wood blocking under bottom carriage assembly.

- 3 Install new preformed packing (5) and tube nipple (6).

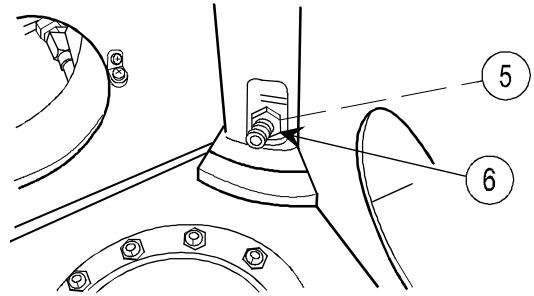

- 4 Install elbow (7) on tube nipple (6) and attach hose assembly (8).

- 5 Install new preformed packing (9) and tube nipple (10).

- 6 Install tube elbow (11).

- 7 Connect hose assembly (12) to tube elbow (11).

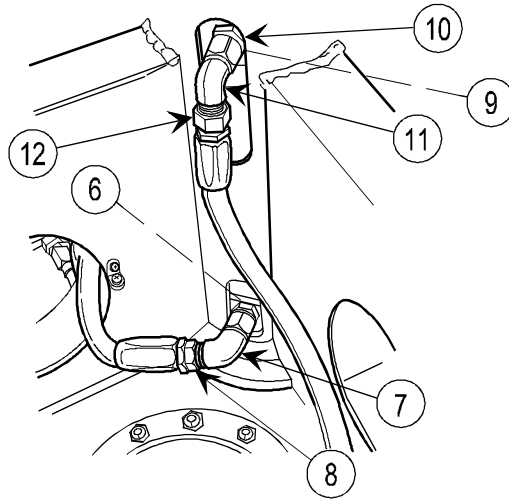

- 8 Remove blocking and carefully lower speed shift cylinder assembly (4) into position, allowing it to rest on lower tube nipple (6).

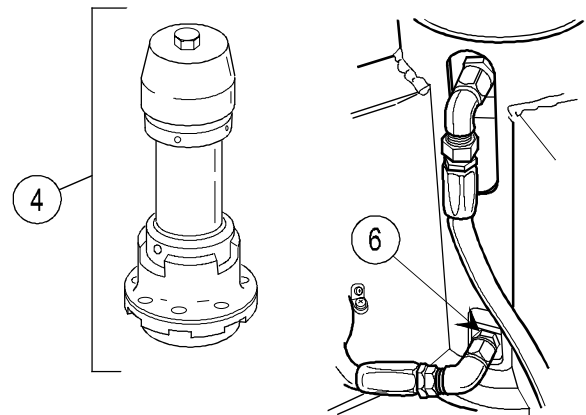

NOTE

Check manifold assembly for proper oil level. Add oil (hydraulic fluid) as required during next step.

- 9 Place SPEED SHIFT handle (12) in DOWN position, and lower rod assembly (13) until it contacts a 10-in. (25-cm) wood block (14) to raise speed shift cylinder assembly into position.

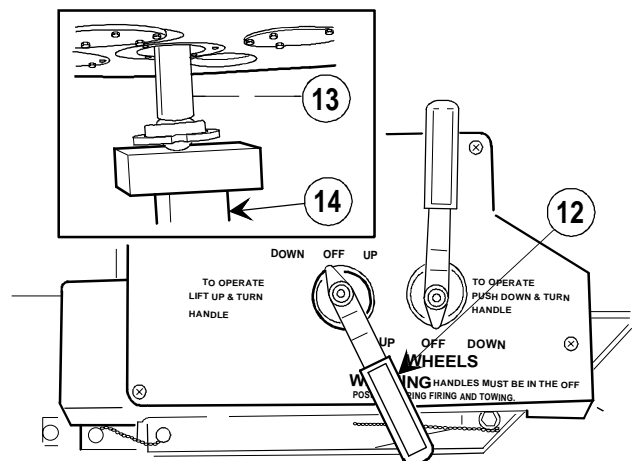

2-41. SPEED SHIFT CYLINDER ASSEMBLY—MAINTENANCE INSTRUCTIONS (cont)

INSTALLATION (cont)

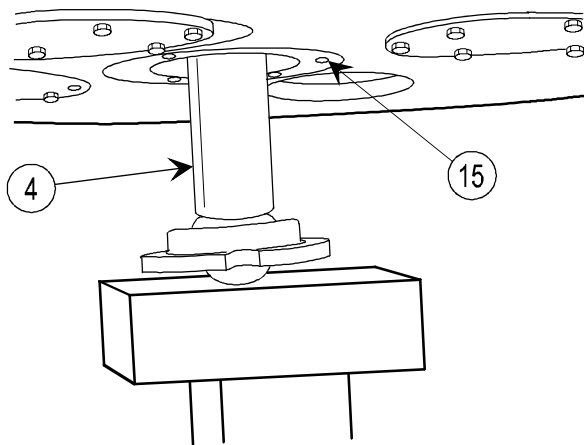

- 10** Aline speed shift cylinder assembly (4) with bottom carriage assembly. Install eight bolts (15). Torque 57 to 63 ft-lb (77 to 83 N-m) and remove wood block.

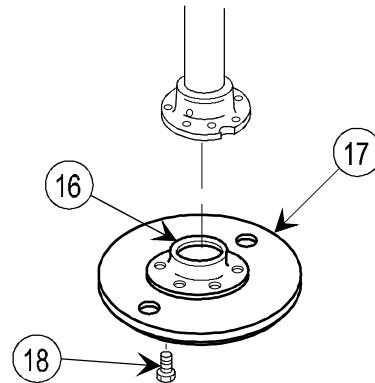

NOTE

Socket ball seat (16) is used with P/N 9324735 speed shift cylinder assembly only.

- 11** Install linear baseplate (17) and socket ball seat (16).
- 12** Install eight bolts (18) and torque bolts 33 to 37 ft-lb (45 to 49 N-m).

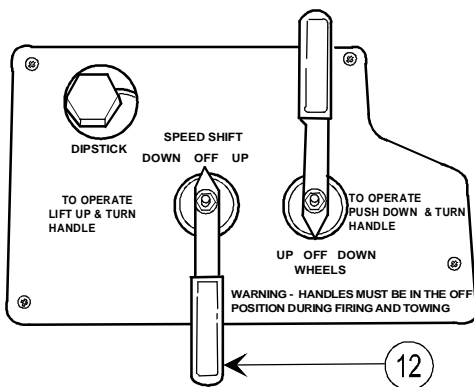

- 13** Lift SPEED SHIFT handle (12) up and place in UP position.

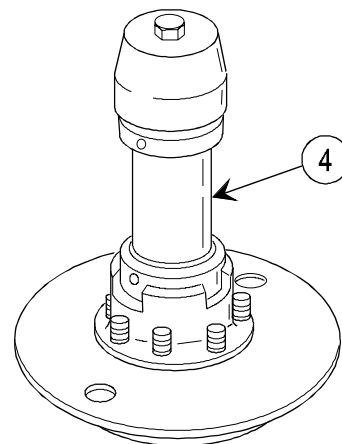

- 14** Using ram hydraulic pump, purge air by lowering speed shift cylinder assembly (4) and retracting several times. Using ram hydraulic pump, raise speed shift cylinder assembly (4) into towed position.

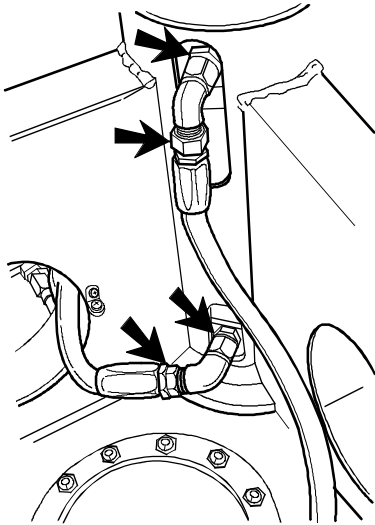

15 Check for leaks in fittings at places indicated by arrows.

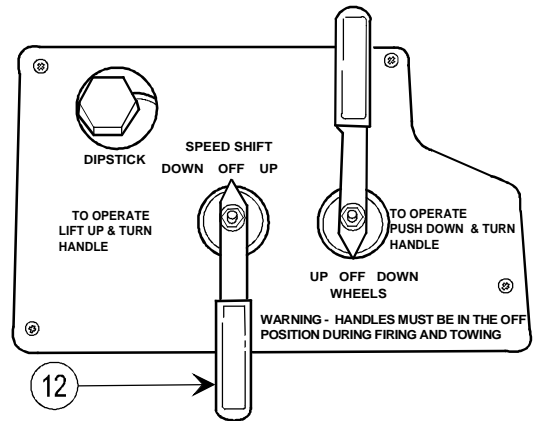

16 Lift SPEED SHIFT handle (12) up and place in OFF position.

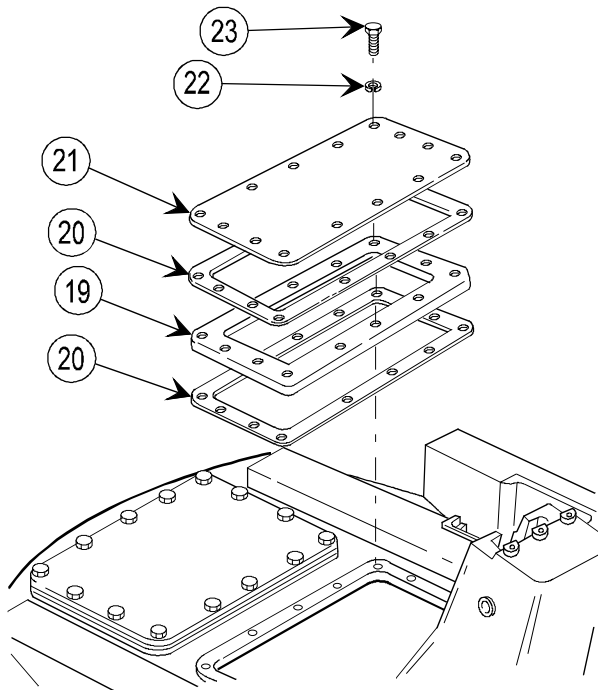

NOTE

Standoff (19) and second gasket (20) apply to modified howitzers only.

17 Install new gaskets (20), standoff (19), and access cover (21).

18 Install 14 lockwashers (22) and 14 capscrews (23).

2-42. ACTUATOR CYLINDER ASSEMBLY—MAINTENANCE INSTRUCTIONS

THIS TASK COVERS:

- a. Removal b. Disassembly c. Inspection/repair d. Reassembly e. Installation

INITIAL SETUP

Tools and Special Tools

- Artillery and turret mechanic's ordnance tool kit (SC 5180-95-CL-A12)
- Artillery field maintenance shop equipment (SC 4933-95-CL-A12)
- M198 repairman field artillery tool kit (5911278)
- Weight and support
3-ton hoist

Materials/Parts

- Gasket (3) (12008773)
- Gasket (12008775)
- Tape (item 32, appx B)
- Wiping rag (item 22, appx B)

Personnel Required: 2

- Artillery repairmen

References

- TM 9-1025-211-10
- TM 9-1025-211-34P

Equipment Conditions

- Trails spread to firing position (TM 9-1025-211-10)
- Cannon traversed 350 mils right (TM 9-1025-211-10)
- 2-232 Traversing angle drive unit removed
- Cannon tube elevated for adequate accessibility (TM 9-1025-211-10)

REMOVAL

WARNING

Howitzer weighs approximately 16,000 lb (7200 kg). Do not work underneath howitzer unless wheels are down and locked or suitable safety supports are positioned under the bottom carriage assembly to prevent the howitzer from falling.

NOTE

Hold trails down with suitable weights (approximately 400 lb (181 kg)) and use speed shift cylinder assembly and wood blocks as required to raise howitzer so that the bottom surface of the bottom carriage assembly has approximately 24 in. (61 cm) ground clearance.

Use suitable blocking to support both sides of the bottom carriage assembly and raise the speed shift cylinder assembly to the UP position. Make sure that blocks will not interfere with removal of access covers. Remove firing assembly baseplate from firing position on bottom carriage assembly if present.

If wheels are not yet in the full down position, make another attempt to lower them (TM 9-1025-211-10). Top carriage assembly may have to be removed (p 2-242) if wheels cannot be lowered to give access to top mounting bolt through the traversing angle drive hole in the top carriage assembly.

- 1 Remove 12 capscrews (1).
- 2 Remove access cover (2) and gasket (3).

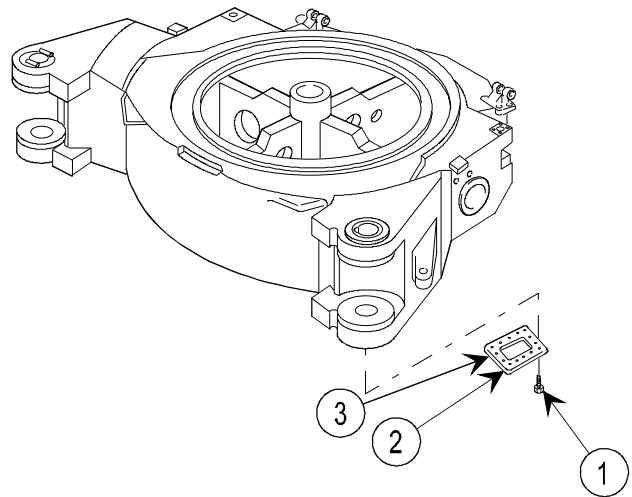

- 3 Remove 18 capscrews (4).
- 4 Remove three access covers (5) and three gaskets (6).

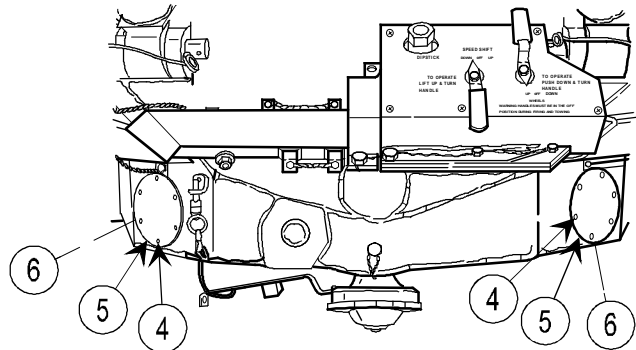

2-42. ACTUATOR CYLINDER ASSEMBLY—MAINTENANCE INSTRUCTIONS (cont)

REMOVAL (cont)

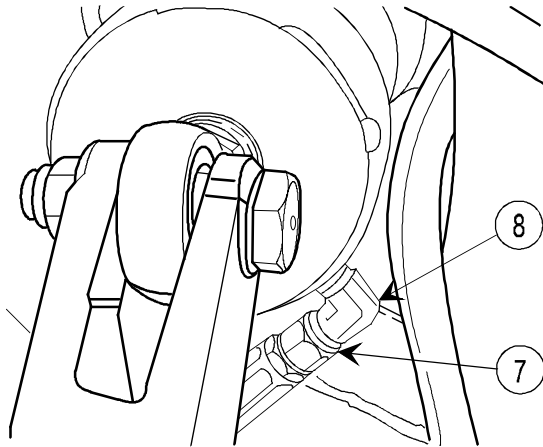

- 5 Unscrew nut (7) and remove from elbow (8).

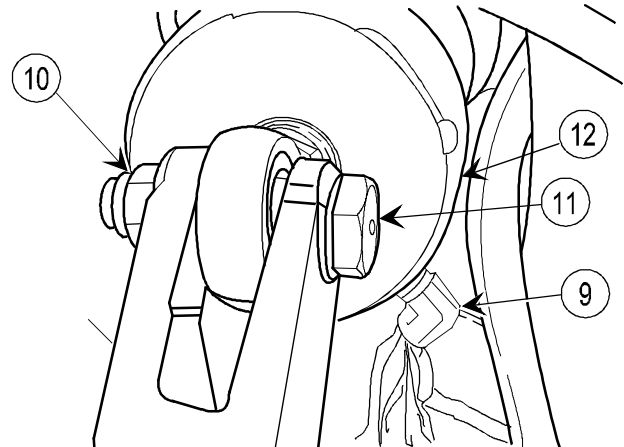

- 6 Cover open end elbow (9) with clean wiping rag.

- 7 Remove nut (10) and bolt (11) to release upper end of actuator cylinder assembly (12).

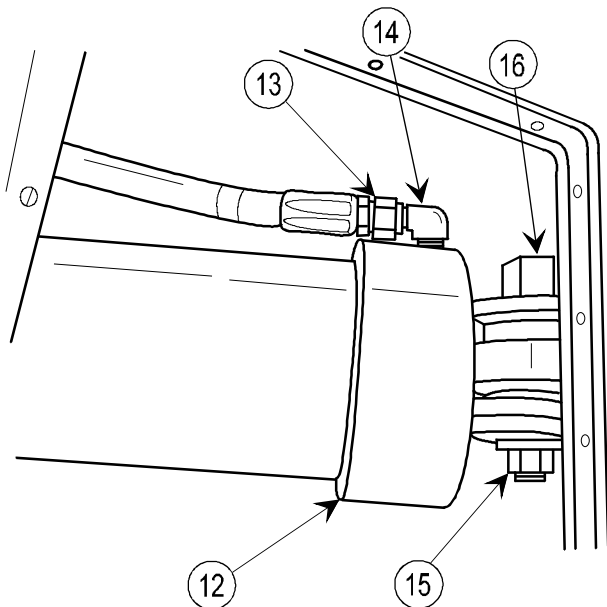

- 8 Remove nut (13) from elbow (14).

- 9 Cover open end elbow (14) with clean wiping rag.

- 10 Remove nut (15) and bolt (16) to release lower end of actuator cylinder assembly (12).

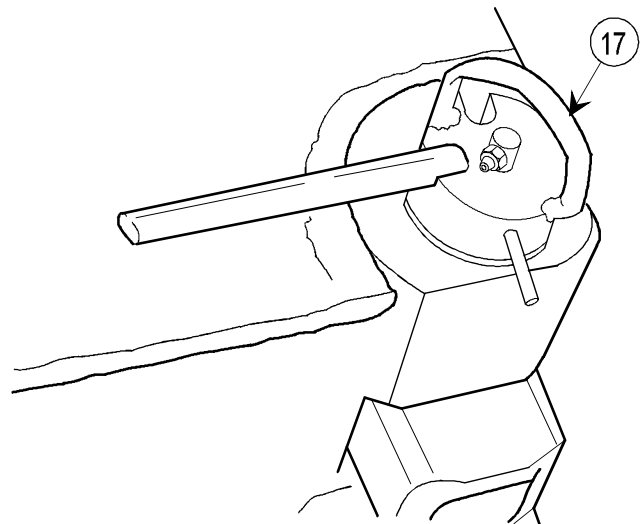

- 11 Release wheel lock handles (17).

- 12 Raise wheels and axle (18) with hoist until arm (19) allows actuator cylinder assembly (12) to release.
- 13 Remove actuator cylinder assembly (12) from bottom carriage assembly (20) through bottom access hole.

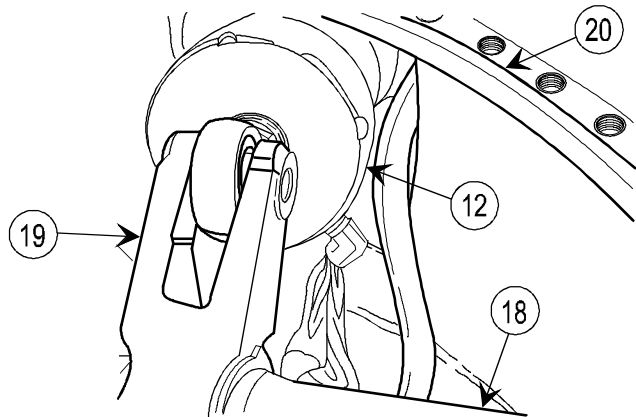

DISASSEMBLY

- 1 Drive out two inserts (1) from bottom carriage assembly (2).

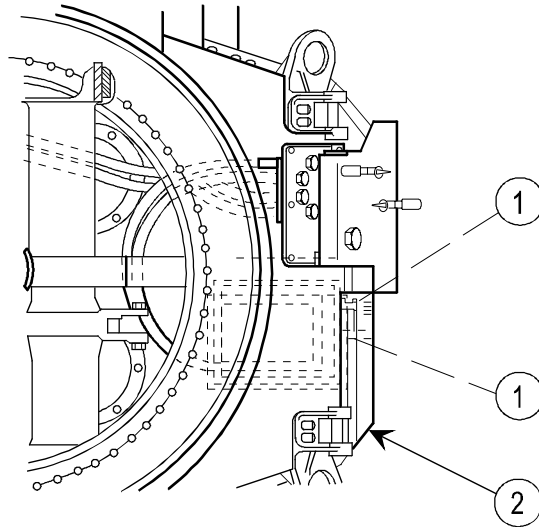

- 2 Unscrew and remove two rod end ball bearings (3) and shim (4).
- 3 Remove two elbows (5 and 6) from actuator cylinder (7).

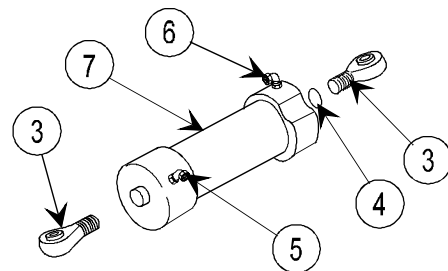

INSPECTION/REPAIR

- 1 Check for broken, damaged, or missing parts.
- 2 Repair is by replacement of authorized parts (TM 9-1025-211-34P).
- 3 Replace actuator cylinder assembly if it is cracked or broken or if the piston will not extend or retract.

2-42. ACTUATOR CYLINDER ASSEMBLY—MAINTENANCE INSTRUCTIONS (cont)

REASSEMBLY

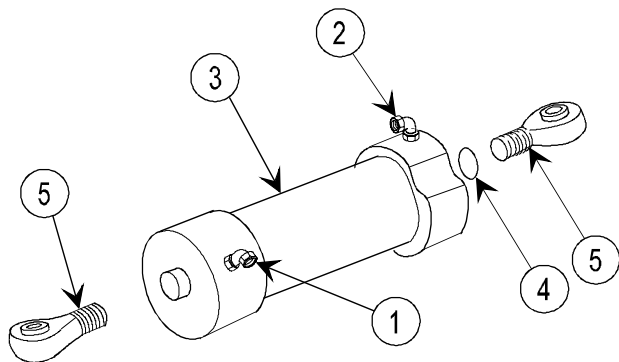

- 1 Wrap pipe threaded ends of two elbows (1 and 2) with tape and install two elbows (1 and 2) on actuator cylinder assembly (3).

NOTE

Adjust laminated shim (4) to achieve proper alignment of rod end from port B or elbow (2).

- 2 Install rod end (5), adding or subtracting laminated shim stock (4) until center line of rod end is positioned 90° from port B or elbow (2).

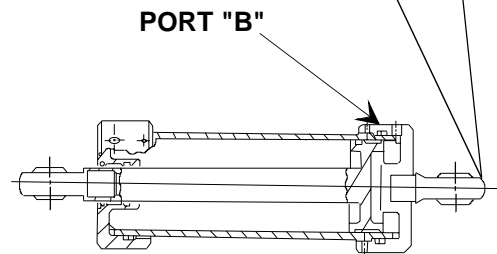
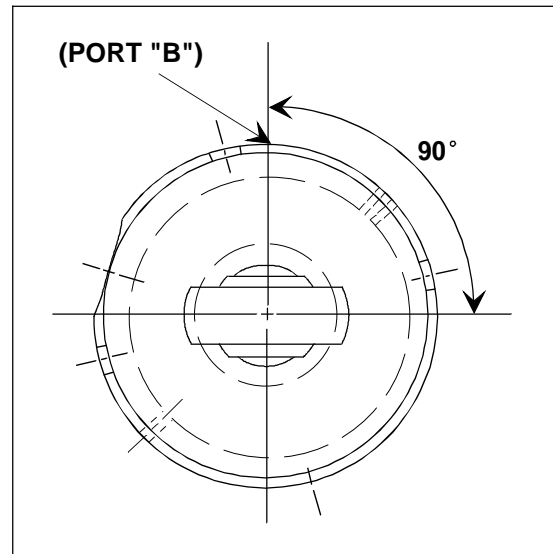

- 3 Install two inserts (6) into bottom carriage assembly (7).

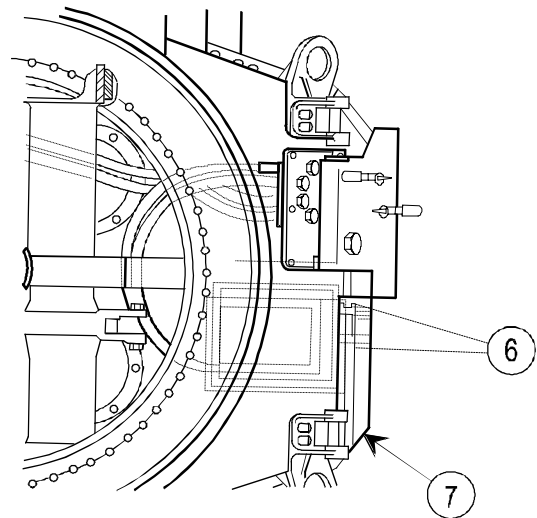

INSTALLATION

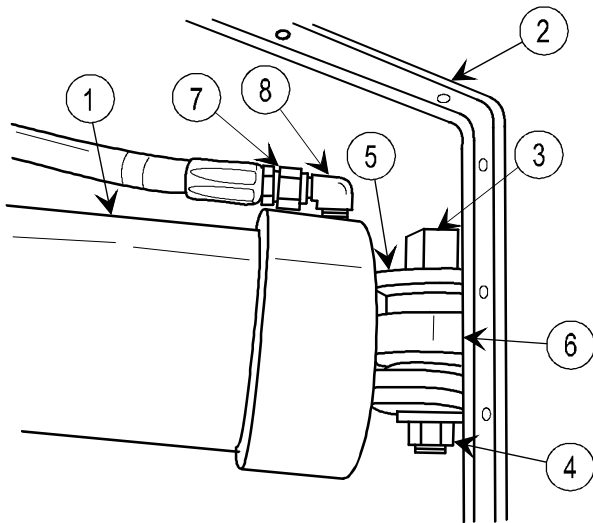

- 1 Install actuator cylinder assembly (1) to bottom carriage assembly (2).
- 2 Install bolt (3) and nut (4) through bracket (5) and rod end ball bearing (6). Torque bolt to 200 ± 20 ft-lb (270 ± 27 N-m).
- 3 Install nut (7) on elbow (8).

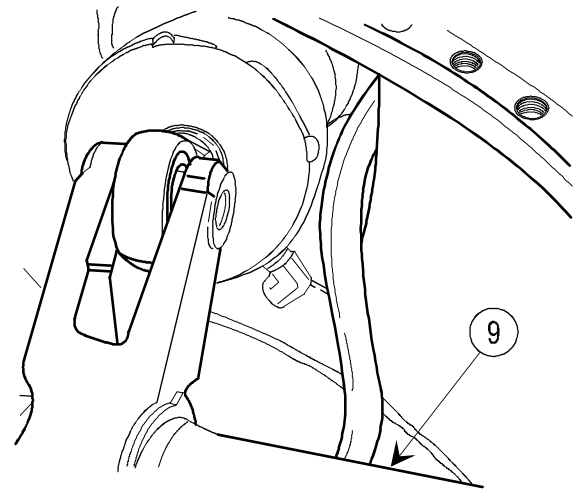

- 4 Lower wheel and axle (9).

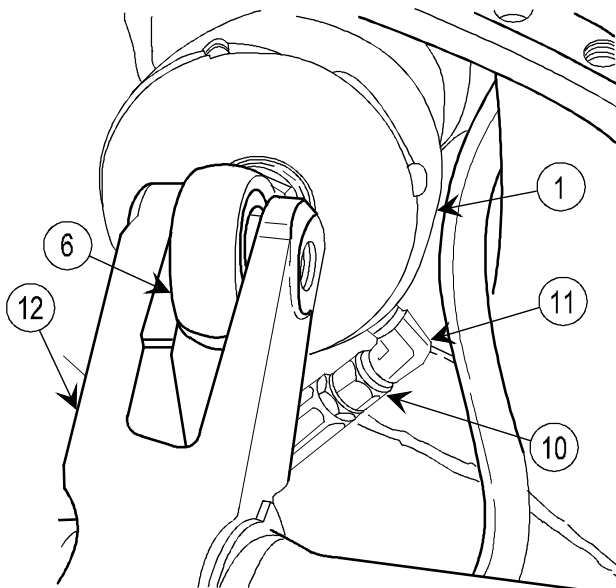

- 5 Install nut (10) on elbow (11).
- 6 Aline arm (12) with rod end ball bearing (6) by extending or retracting piston of actuator cylinder assembly (1).

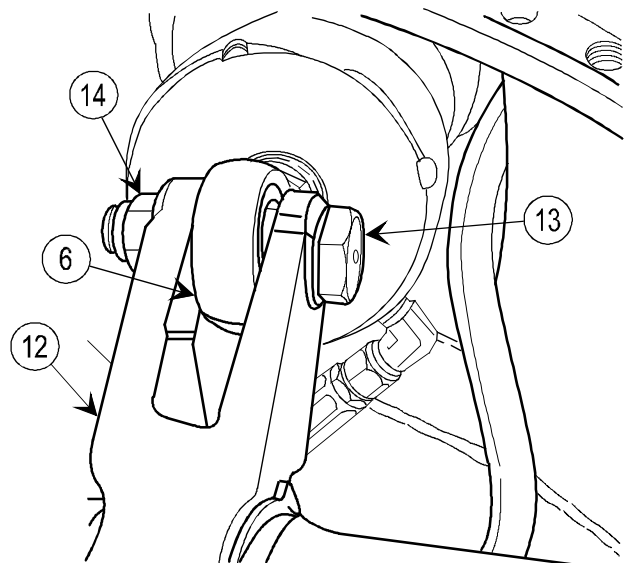

- 7 Install bolt (13) and nut (14) through arm (12) and rod end ball bearing (6). Torque bolt to 200 ± 20 ft-lb (270 ± 27 N-m).

2-42. ACTUATOR CYLINDER ASSEMBLY—MAINTENANCE INSTRUCTIONS (cont)

INSTALLATION (cont)

- 8 Place WHEELS handle (15) in UP position, and activate ram hydraulic pump until pressure builds up.
- 9 Place WHEELS handle (15) in DOWN position, and activate ram hydraulic pump until pressure builds up.
- 10 Repeat steps 8 and 9 several times until air is purged. (Maintain level of oil (hydraulic fluid) in manifold assembly.)
- 11 Check for oil leaks.

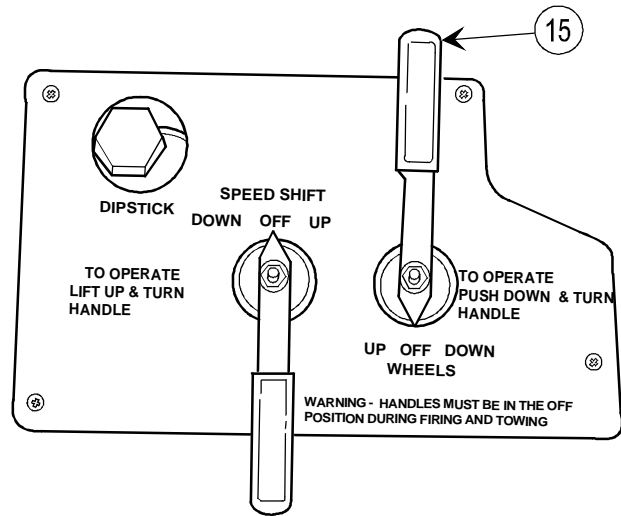

- 12 Engage wheel lock handles (16).

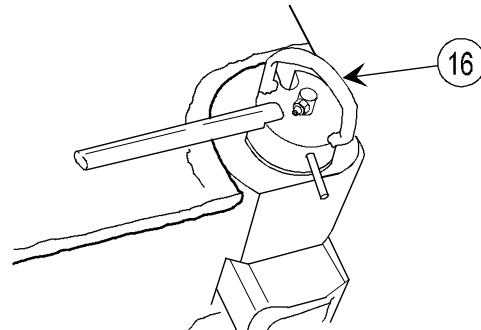

NOTE

Remove bottom carriage from blocks, then remove weight from trails.

- 13 Position three new gaskets (17) and three access covers (18).
- 14 Install 18 capscrews (19).

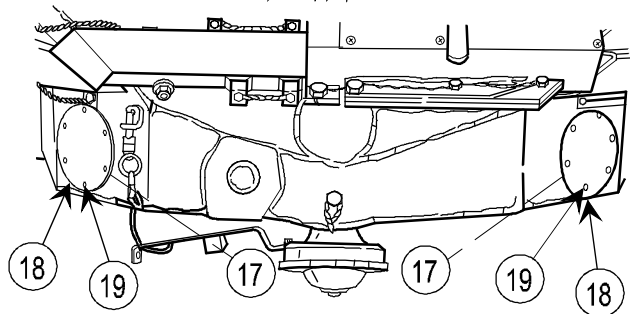

- 15 Install new gasket (20) and access cover (21).
- 16 Install 12 capscrews (22).

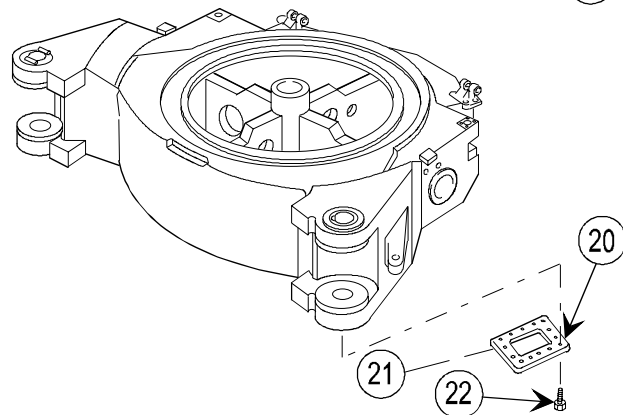

2-43. DETENT ASSEMBLY—MAINTENANCE INSTRUCTIONS

THIS TASK COVERS:

- a. Removal b. Disassembly c. Inspection/repair d. Reassembly e. Installation

INITIAL SETUP

Tools and Special Tools

Artillery and turret mechanic's ordnance tool kit (SC 5180-95-CL-A12)

Materials/Parts

Lubricant, solid film (item 14.1, appx B)

Plastic pellet (8436778)

References

TM 9-1025-211-10

TM 9-1025-211-34P

Equipment Conditions

Wheels down and locked (TM 9-1025-211-10)

Firing assembly baseplate removed from detent assembly and locking assembly
(TM 9-1025-211-10)

REMOVAL

Unscrew detent assembly (1) from detent assembly ball (2), and remove.

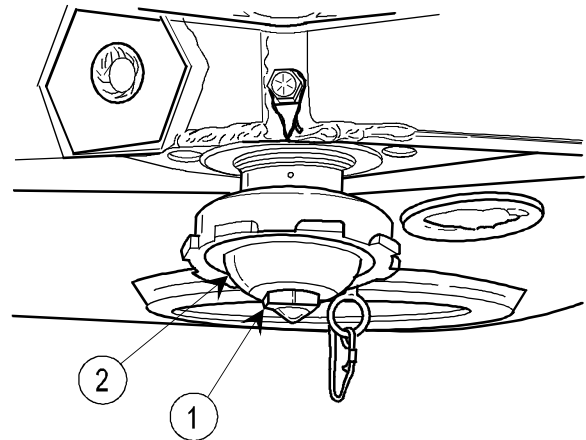

DISASSEMBLY

- 1 Remove plug (1) from body (2).
- 2 Remove 15 spring tension washers (3).
- 3 Remove bearing seat (4).
- 4 Remove bearing ball (5).
- 5 Remove plastic pellet (6) from body (2).

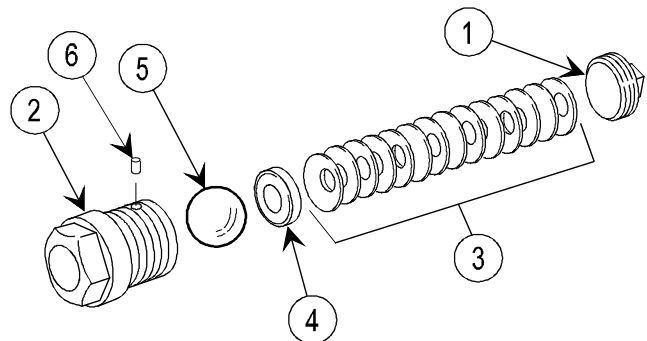

2-43. DETENT ASSEMBLY—MAINTENANCE INSTRUCTIONS (cont)

INSPECTION/REPAIR

- 1 Check for broken, damaged, or missing parts.
- 2 Repair is by replacement of authorized parts (TM 9-1025-211-34P).
- 3 Replace detent assembly if bearing ball of body is cracked or broken.
- 4 If rust is present, remove the rust from ball detent assembly and apply a light coat of solid film lubricant.

REASSEMBLY

- 1 Install bearing ball (1).
- 2 Install bearing seat (2).

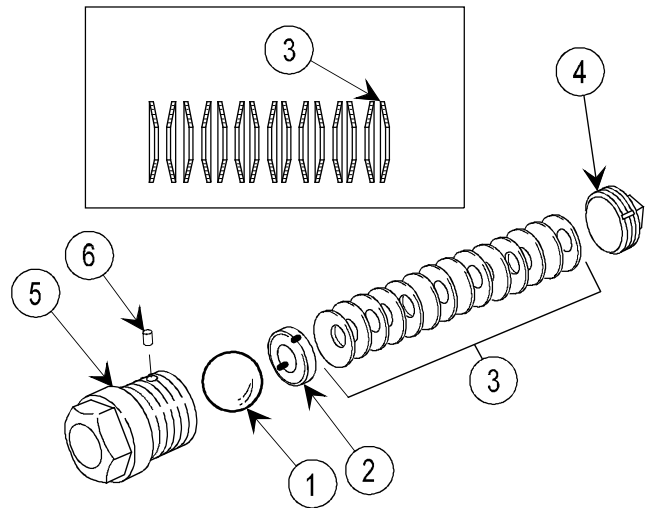

- 3 Install 15 spring tension washers (3) alternately with first washer cup side down, and second washer cup side up. Continue until all are installed.
- 4 Install plug (4) and tighten until outside edge is flush with face of body (5).
- 5 Install new plastic pellet (6) in body (5).

INSTALLATION

Install detent assembly and torque to 100 + 10 ft-lb
(135 + 13 N-m).

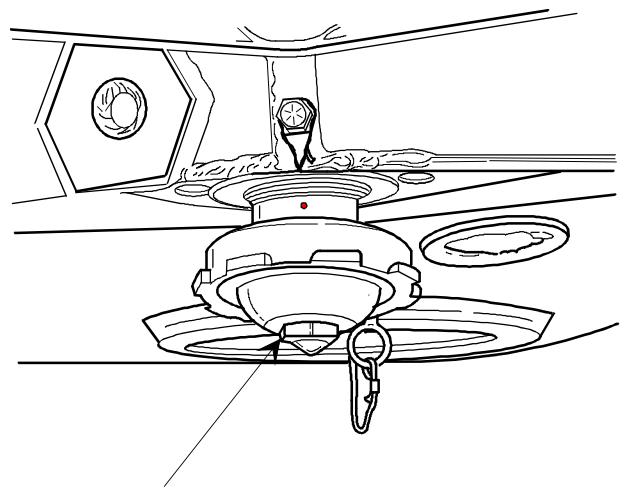

DETENT ASSEMBLY

REASSEMBLY

- 1 Install lock release cam (1) and detent assembly ball (2) into bottom carriage assembly (3), and align drilled hole in detent assembly ball (2) with threaded hole in bottom carriage assembly (3).
- 2 Coat bolt (4) with sealing compound and install and tighten lockwasher (5) and bolt (4). Install lock wire (6).
- 3 Install detent assembly (7) and torque to 100 + 10 ft-lb (135 + 13 N-m).

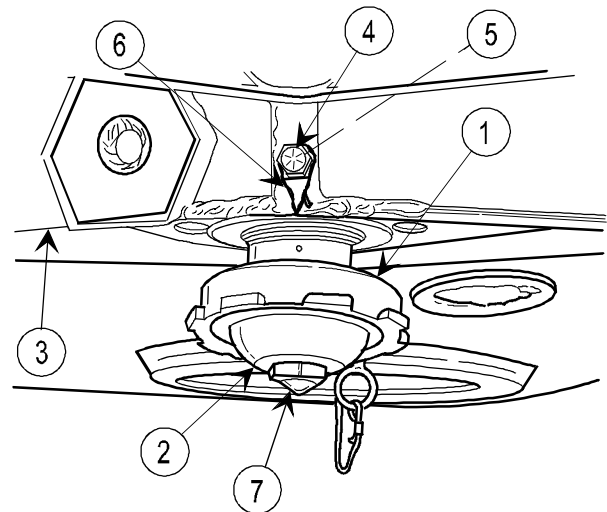

2-45. RIGHT AND LEFT MANUAL BRAKE ASSEMBLY—MAINTENANCE INSTRUCTIONS

THIS TASK COVERS:

- | | | |
|---------------|----------------|----------------------|
| a. Deleted | b. Disassembly | c. Inspection/repair |
| d. Reassembly | e. Deleted | f. Deleted |

INITIAL SETUP

Tools and Special Tools

Artillery and turret mechanic's ordnance tool kit (SC 5180-95-CL-A12)

Materials/Parts

Cotter pin (MS24665-353)

References

TM 9-1025-211-20&P

TM 9-1025-211-34P

Equipment Conditions

Right and left manual brake assembly removed and partially disassembled (TM 9-1025-211-20&P)

NOTE

All data on page 2-309 deleted.

2-45. RIGHT AND LEFT MANUAL BRAKE ASSEMBLY—MAINTENANCE INSTRUCTIONS (cont)

DISASSEMBLY

- 1 Remove cotter pin (1).
- 2 Remove washer (2).
- 3 Remove pin (3).
- 4 Remove manual brake socket (4) from bracket (5).
- 5 Remove sleeve bearing (6) from manual brake socket (4).

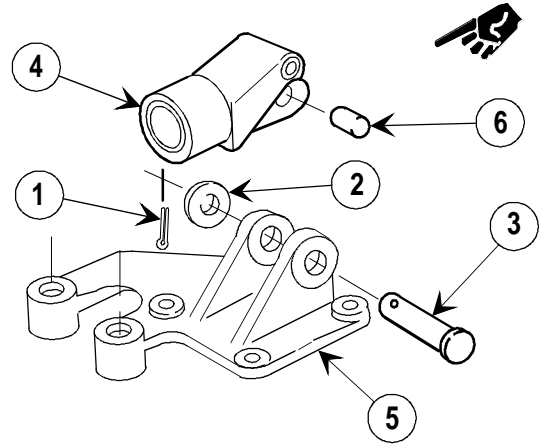

INSPECTION/REPAIR

- 1 Check for broken, damaged, or missing parts.
- 2 Repair is by replacement of authorized parts (TM 9-1025-211-34P).

NOTE

All data on page 2-311 deleted.

2-45. RIGHT AND LEFT MANUAL BRAKE ASSEMBLY—MAINTENANCE INSTRUCTIONS (cont)

REASSEMBLY

- 1 Install sleeve bearing (1) in manual brake socket (2).
- 2 Aline manual brake socket (2) hole with holes on bracket (3).
- 3 Install pin (4) through manual brake socket (2) and bracket (3).
- 4 Install washer (5) and new cotter pin (6).

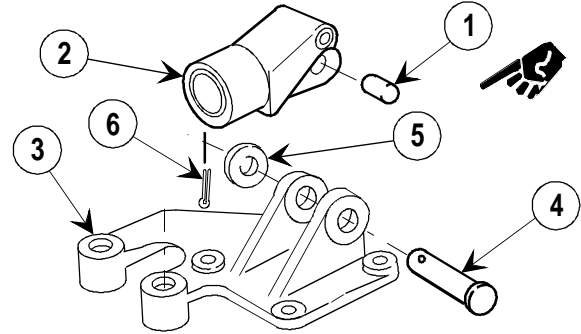

NOTE

All data on page 2-313 deleted.

2-46. BRAKE HEAD ASSEMBLIES—MAINTENANCE INSTRUCTIONS

THIS TASK COVERS:

- a. Deleted b. Disassembly c. Inspection/repair d. Reassembly e. Deleted

INITIAL SETUP

Tools and Special Tools

- Artillery and turret mechanic's ordnance tool kit (SC 5180-95-CL-A12)
- Artillery field maintenance shop equipment (SC 4933-95-CL-A12)

Materials/Parts

- Lock wire (item 38, appx B)

References

- TM 9-1025-211-10
- TM 9-1025-211-20&P
- TM 9-1025-211-34P

Equipment Conditions

- 2-230 Wheel and tire removed
- Weapon in firing position (TM 9-1025-211-10)
- Brake head assemblies removed and partially disassembled (TM 9-1025-211-20&P)

NOTE

All data on page 2-315 deleted.

2-46. BRAKE HEAD ASSEMBLIES—MAINTENANCE INSTRUCTIONS (cont)

DISASSEMBLY

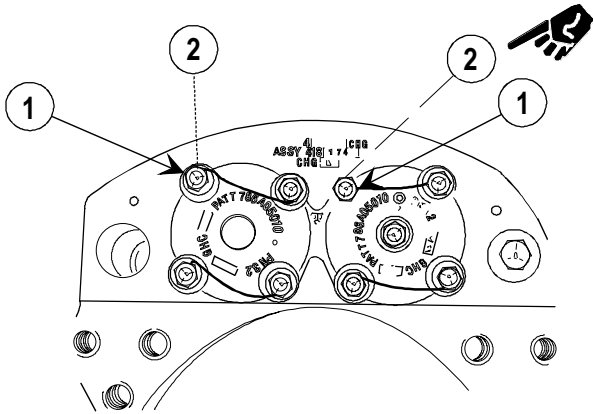

1 Remove eight capscrews (1) and eight washers (2).

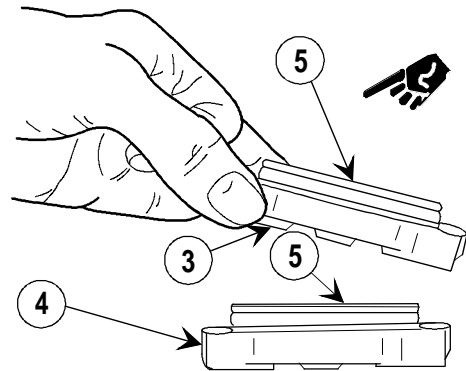

2 Remove two caps (3 and 4) and two packings (5).

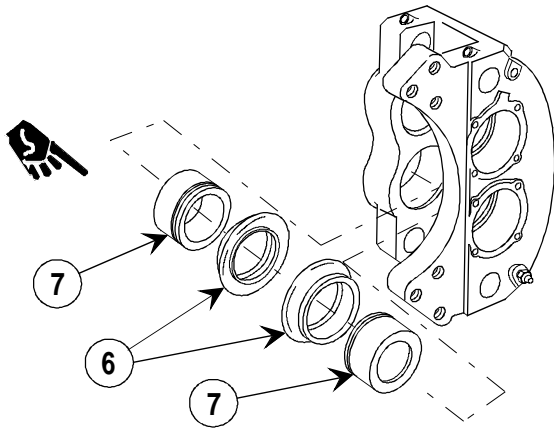

3 Remove four boots (6) and four pistons (7).

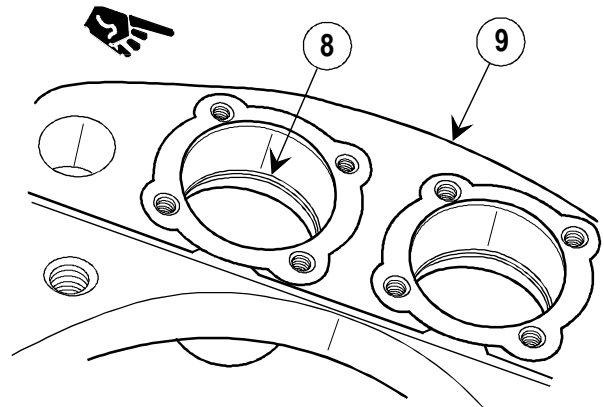

4 Remove four packings (8) from torque plate assembly (9).

INSPECTION/REPAIR

- 1 Check for broken, damaged, or missing parts.
- 2 Repair is by replacement of authorized parts (TM 9-1025-211-34P).

REASSEMBLY

NOTE

For first time installation of mud deflectors, order all parts identified in TM 9-1025-211-34P. The four screws should be removed and replaced with the new, longer screws if mud deflectors are installed.

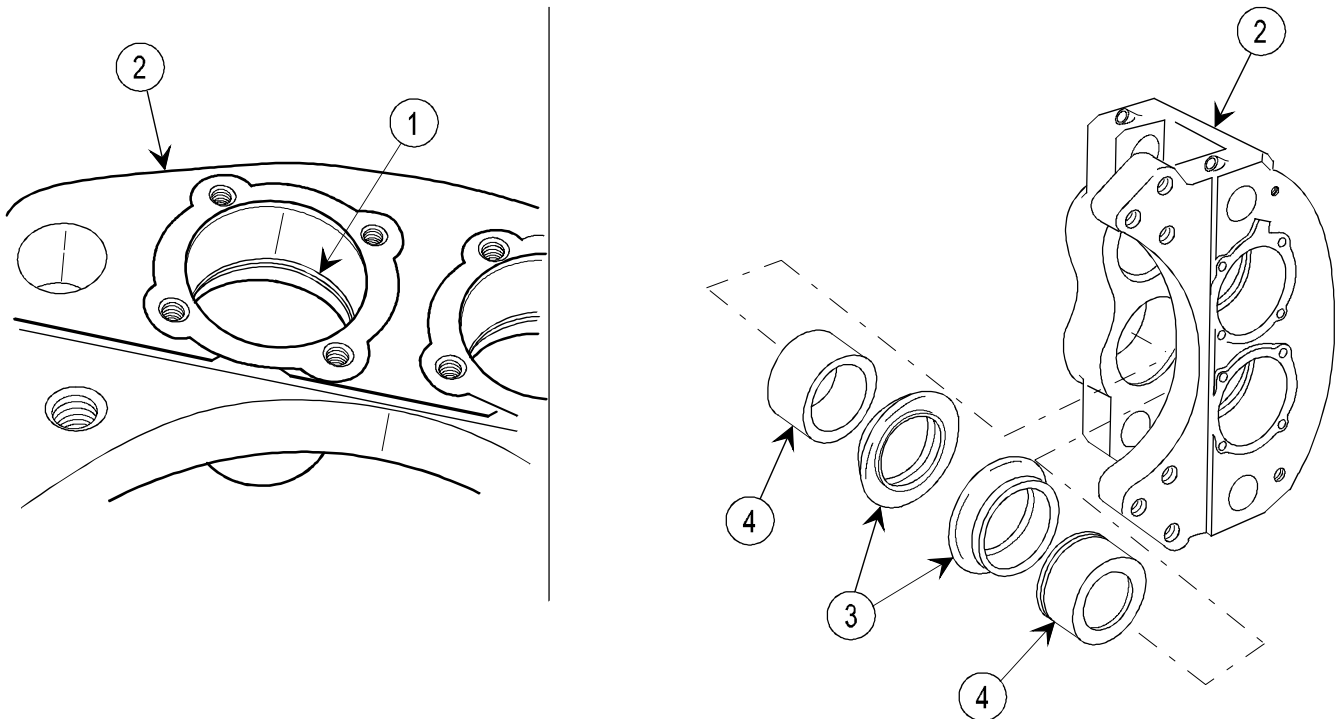

- 1 Install four packings (1) in torque plate assembly (2).
- 2 Install four boots (3) in groove of torque plate assembly (2).
- 3 Install four pistons (4) through recess in torque plate assembly (2).

2-46. BRAKE HEAD ASSEMBLIES—MAINTENANCE INSTRUCTIONS (cont)

REASSEMBLY (cont)

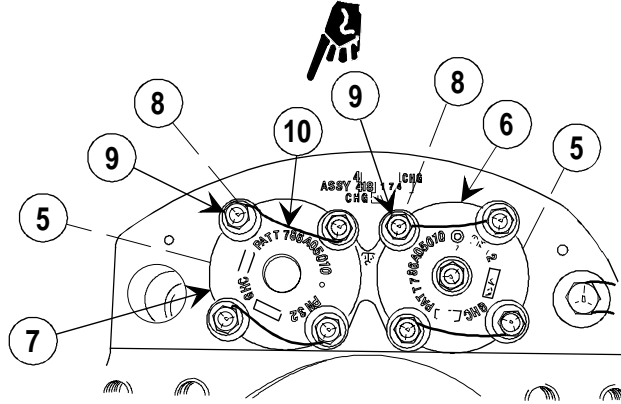

- 4 Install two packings (5) and two caps (6 and 7).
- 5 Install eight washers (8) and eight capscrews (9).
- 6 Install lock wires (10) (item 38, appx B).

NOTE

All data on page 2-319 deleted.

2-47. BOTTOM CARRIAGE ASSEMBLY - WHEEL AND AXLE PARTS—MAINTENANCE INSTRUCTIONS

THIS TASK COVERS:

- a. Disassembly b. Inspection/repair c. Reassembly d. Adjustment

INITIAL SETUP

Tools and Special Tools

- Artillery and turret mechanic's ordnance tool kit (SC 5180-95-CL-A12)
- Artillery field maintenance shop equipment (SC 4933-95-CL-A12)
- M198 field artillery repairman tool kit (5911278)
- 3-ton hoist and sling

Materials/Parts

- Antiseize compound (item 4, appx B)
- Cleaning compound (item 7, appx B)
- Lock wire (item 34, appx B)
- Lock wire (item 35, appx B)
- Preformed packing (2) (12008301-1)
- Preformed packing (2) (12008301-2)
- Sealing compound (item 25, appx B)
- Sealing compound (item 27, appx B)
- Spring pin (8) (MS16562-77)
- WTR grease (item 11, appx B)

Personnel Required: 2

References

- TM 9-1025-211-10
- TM 9-1025-211-20&P
- TM 9-1025-211-34P

Equipment Conditions

- 2-23 M199 cannon removed
- 2-58 M45 recoil mechanism removed
- 2-242 Top carriage assembly removed
- 2-298 Actuator cylinder assembly disconnected from arm and weapon left on supports
- 2-314 Brake head assembly removed
- 2-308 Left and right manual brake assemblies removed
- Unit maintenance procedures performed (TM 9-1025-211-20&P)
- Baseplate installed and wheels in up position (TM 9-1025-211-10)
- Tire and wheel removed (TM 9-1025-211-20&P)
- Hub and disk removed (TM 9-1025-211-20&P)
- Blocking available

General Safety Instructions

WARNING

All lifting devices must be checked in accordance with local Standing Operating Procedure (SOP) to make sure they are in good working condition before starting the lifting operation.

DISASSEMBLY

NOTE

Procedures apply to both sides of howitzer; however, only one side is shown.

- 1 Remove ten bolts (1).
- 2 Measure disk (2) for wear or damage. If worn below 0.450 in. (1.143 cm) or damaged beyond use, replace.
- 3 Remove lock wire and eight bolts (3), eight washers (4), and disk (2).

NOTE

Ring spacer (5) is bonded to spindle (6) and should not be removed unless necessary for replacement of authorized parts.

- 4 Remove ring spacer (5) if necessary.

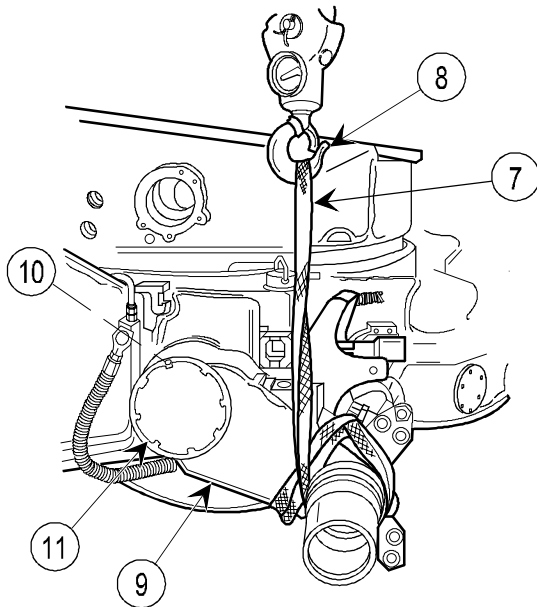
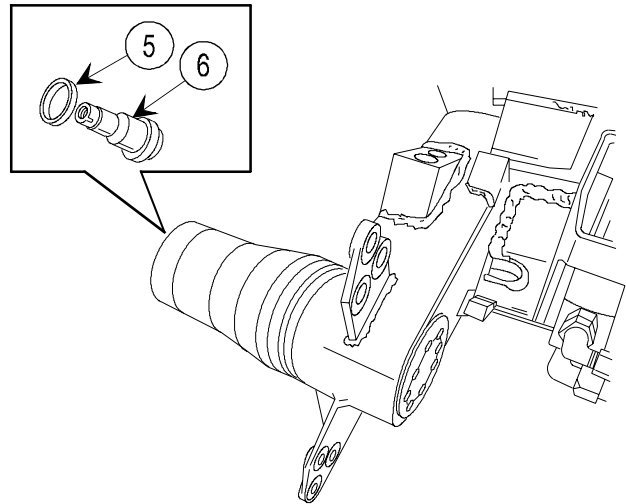
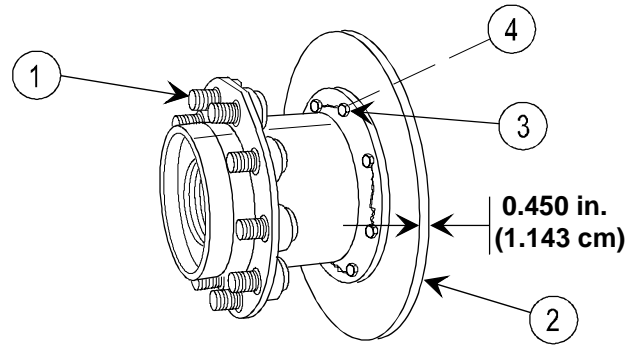

NOTE

Use sling (7) and hoist (8) in removing arm and spindle assembly (9).

- 5 Remove self-locking screw (10), if installed on arm and spindle assembly.
- 6 Remove machine thread plug (11).
- 7 Remove arm and spindle assembly (9).

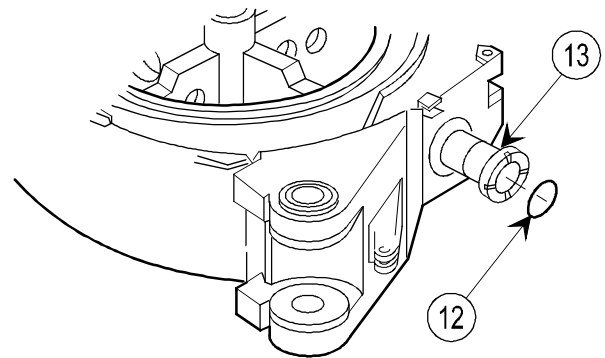

NOTE

Refer to p 2-326 for maintenance of arm and spindle assembly.

- 8 Remove preformed packing (12) from sleeve bushing (13).

2-47. BOTTOM CARRIAGE ASSEMBLY – WHEEL AND AXLE PARTS—MAINTENANCE INSTRUCTIONS (cont)

DISASSEMBLY (cont)

NOTE

Remove parts from opposite side before proceeding to step 9.

- 9 Remove retaining ring (14) from groove in axle (15) and slide outward on axle.
- 10 Slide arm (16) outward off spline on axle (15).
- 11 Remove retaining ring (17) from groove in axle (15) and slide along axle (15) in same direction as arm (16).
- 12 Slide axle (15) out in direction of arrow until retaining rings (14 and 17) and arm (16) can be removed.

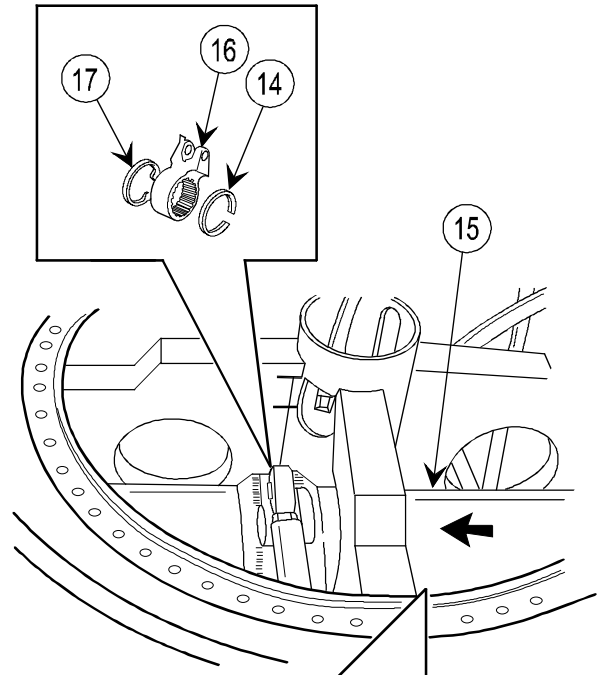

NOTE

Check orientation of arm (16) before removal to ensure it is assembled in the same manner.

- 13 Remove retaining ring (14), arm (16), and retaining ring (17).
- 14 Remove sleeve bushing (13), preformed packing (18), and axle (15).
- 15 Remove four spring pins (19) and packing (20).

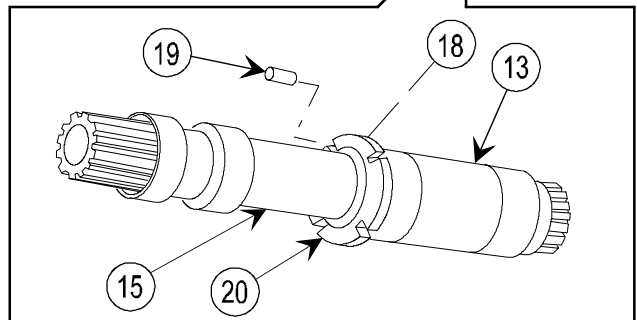

INSPECTION/REPAIR

- 1 Check for broken, damaged, or missing parts.
- 2 Repair is by replacement of authorized parts (TM 9-1025-211-34P).

WARNING

Cleaning solvent is toxic and flammable. Use in well-ventilated area. Avoid breathing the vapors and keep away from ignition sources.

- 3 Thoroughly clean all parts as required with cleaning compound (item 7, appx B) and repack bearings with WTR grease (item 11, appx B).

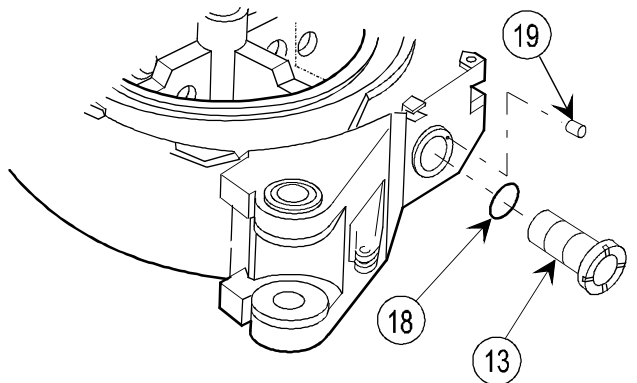

REASSEMBLY

- 1 Install four new spring pins (1) in bottom carriage assembly (2).
- 2 Install new preformed packing (3) on sleeve bushing (4).

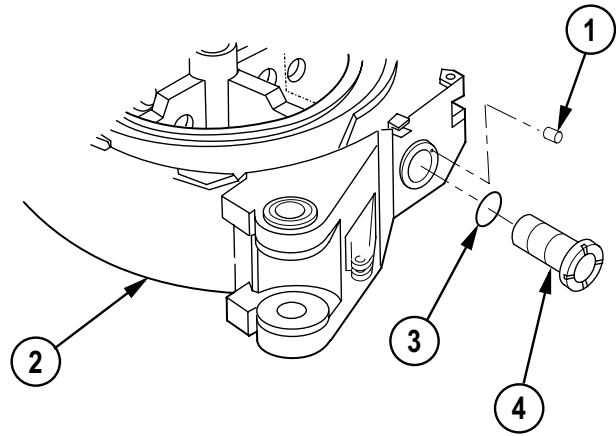

NOTE

Align grease hole in sleeve bushing (4) with hole in bottom carriage assembly (2).

- 3 Install second sleeve bushing (4) and packing (3) in left side of bottom carriage assembly (2).

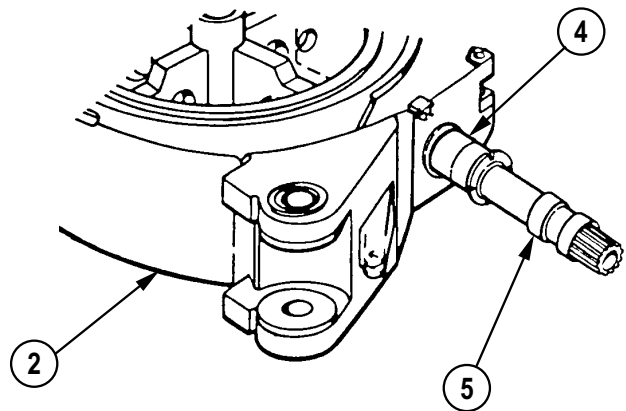

- 4 Partially install axle (5) through reinforcement structure (6), allowing clearance for installation of arm (7).

NOTE

All splines on axle (5) must be coated with antiseize compound before positioning arm (7) on spline.

- 5 Position retaining ring (8), arm (7), and retaining ring (9) on axle (5).

- 6 Install axle (5) completely.

NOTE

Align timing marks on arm (7) and axle (5) prior to starting arm on splines.

- 7 Install retaining ring (8), arm (7), and retaining ring (9) completely.

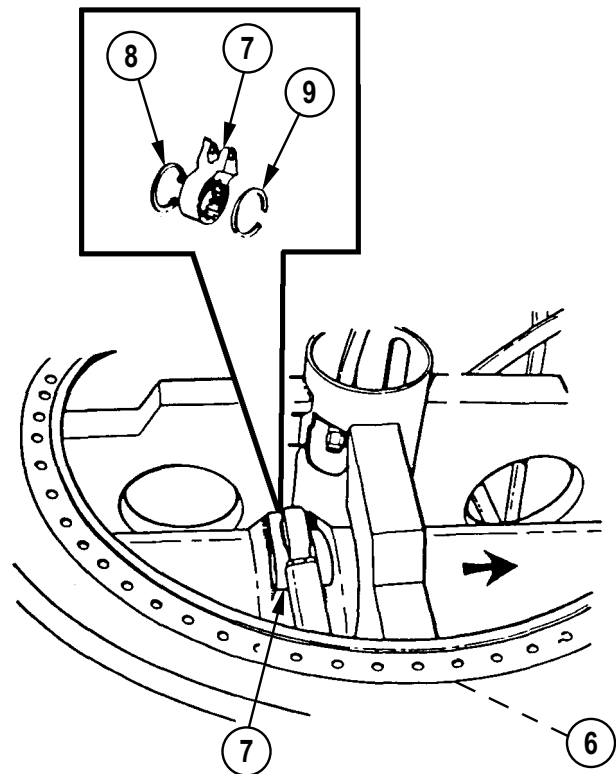

2-47. BOTTOM CARRIAGE ASSEMBLY - WHEEL AND AXLE PARTS—MAINTENANCE INSTRUCTIONS (cont)

REASSEMBLY (cont)

CAUTION

Aline timing mark on spindle and arm assembly with those on axle to ensure both arms are at the same height. Wheel lock may not engage if arms are out of time.

NOTE

Procedures are written for only one side, but apply to both sides.

- 8 Install new preformed packing (11) and arm and spindle assembly (12). Remove sling (13) and hoist (14).

NOTE

Apply sealing compound (item 25, appx B) to mating threads of axle and machine thread plug.

Machine thread plugs (15) must be adjusted to provide 0.005- to 0.010-in. (0.130- to 0.250-mm) clearance between arm and spindle assembly (12) and sleeve bushings (4).

- 9 Coat threads of machine thread plug (15) with sealing compound (item 25, appx B) and install if spindle and arm assembly is not drilled and tapped for self-locking screw (16).

NOTE

See adjustment procedures for clearance between arm and spindle assembly and bottom carriage.

- 10 Install self-locking screw (16) if removed during disassembly. Torque self-locking screw (16) to 70 to 80 in.-lb (8 to 9 N-m).

- 11 Apply sealing compound (item 25, appx B) to ring spacer (17), then install on spindle (18).

NOTE

Allow sealing compounds to cure before performing next step.

- 12 Install ten bolts (19) using hydraulic press.

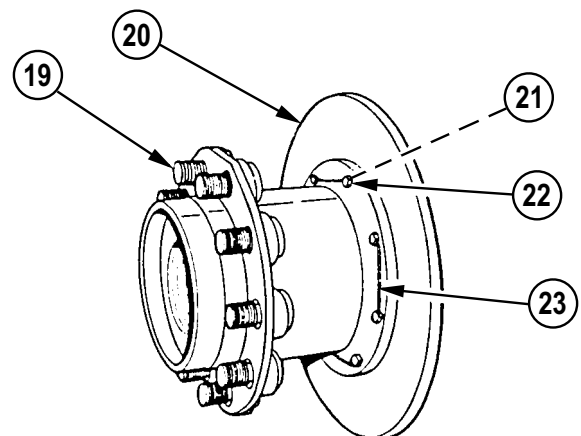
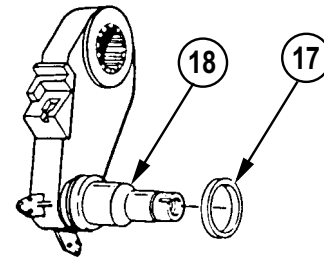
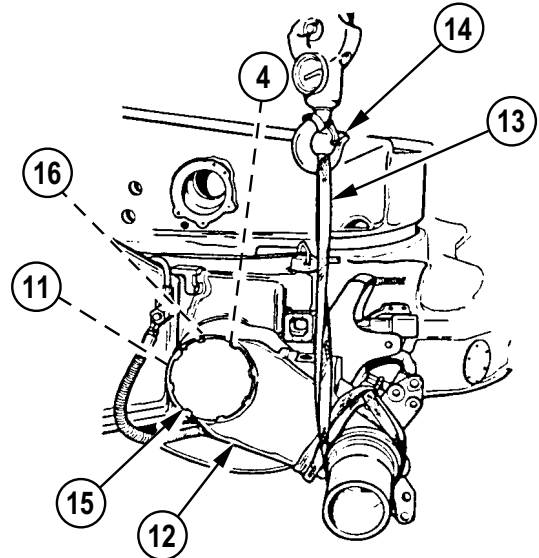

- 13 Install disk (20), eight washers (21), eight bolts (22), and lock wire (23).

ADJUSTMENT

- 1 Position handling bar (1) between arm and spindle assembly (2) and bottom carriage (3). Pry arm and spindle assembly away from the bottom carriage.
- 2 Insert feeler gage between arm and spindle assembly (2) and bottom carriage (3) to measure actual clearance.

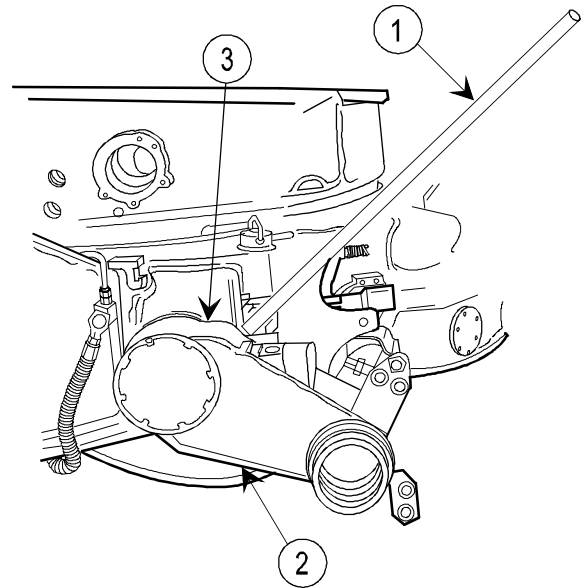

NOTE

The clearance between bushing (4) and arm and spindle assembly (2) should be 0.005 to 0.010 in. (0.130 to 0.250 mm).

- 3 To change the amount of clearance, rotate one of the machine thread plugs (5) clockwise to reduce clearance or counterclockwise to increase clearance.
- 4 If machine plug (5) is held in place with self-locking screw (6), rotate plug far enough to install screw. Repeat steps 1 and 2 to verify proper clearance.

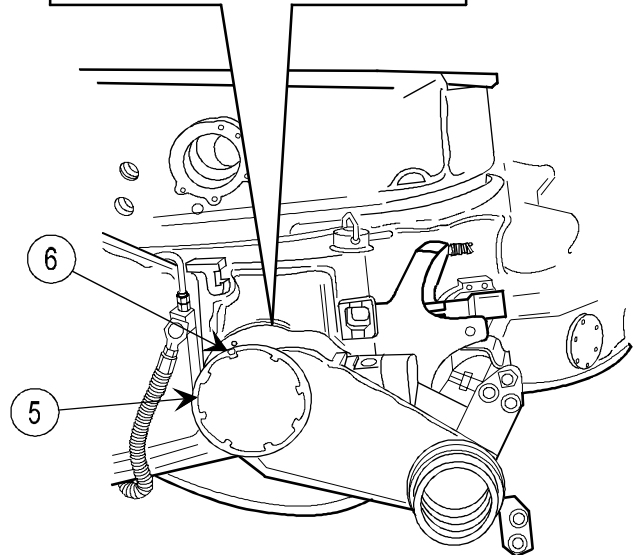
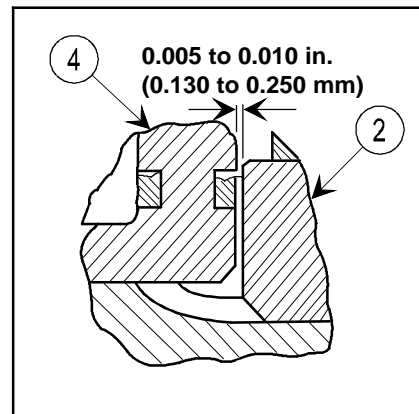

2-48. ARM AND SPINDLE ASSEMBLY—MAINTENANCE INSTRUCTIONS

THIS TASK COVERS:		
a. Disassembly	b. Inspection/repair	c. Reassembly
INITIAL SETUP		
Tools and Special Tools		
Artillery field maintenance shop equipment (SC 4933-95-CL-A12)		
Artillery and turret mechanic's ordnance tool kit (SC 5180-95-CL-A12)		
Hydraulic press		
Materials/Parts		
Lock wire (item 35, appx B)		
Sealing compound (item 25, appx B)		
References		
TM 9-1025-211-34P		
Equipment Conditions		
2-320 Arm and spindle assembly removed		

DISASSEMBLY

NOTE

There are two arm and spindle assemblies on the howitzer. Procedures are written for one but apply to both.

Steps 1 and 2 apply to the primary design, and steps 3 thru 5 apply to an alternate design used on a limited number of howitzers.

- 1** Remove three setscrews (1).

CAUTION

Spindle (2) is press-fitted into arm (3). Pressure must be applied to spindle within 7/16 in. (11 mm) of inside diameter of arm to avoid damaging spindle. Do not remove spindle from arm unless necessary for replacement of authorized parts (TM 9-1025-211-34P).

- 2** Remove spindle (2) from arm (3) using hydraulic press (not shown).

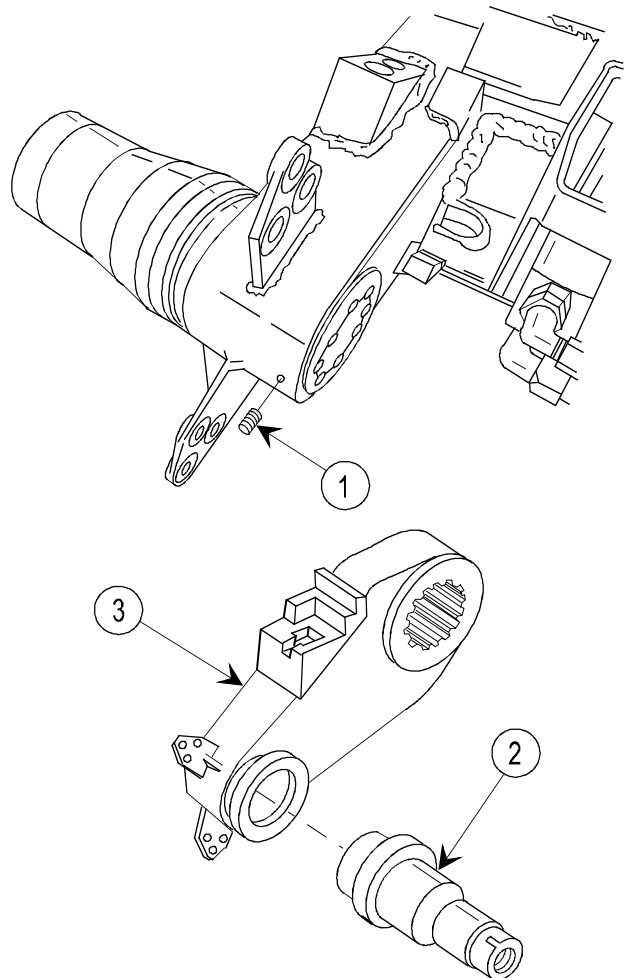

- 3 Remove lock wire (4) and eight capscrews (5).
- 4 Remove spindle (6) from arm (7), using hydraulic press if necessary.
- 5 Deleted.

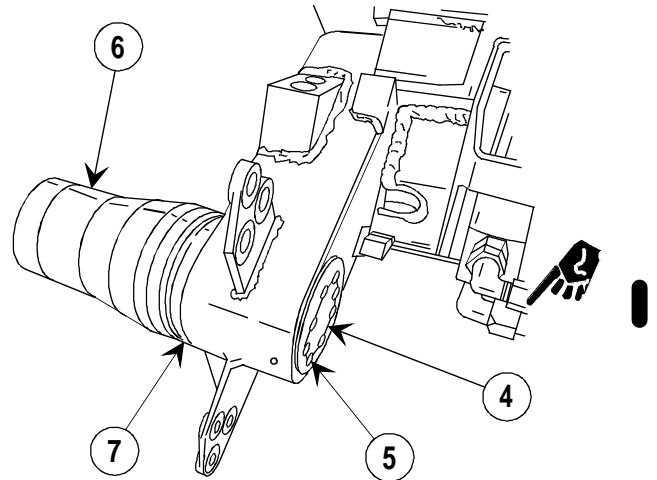

INSPECTION/REPAIR

- 1 Check for broken, damaged, or missing parts.
- 2 Repair is by replacement of authorized parts (TM 9-1025-211-34P).

REASSEMBLY

NOTE

Steps 1 thru 4 apply to alternate design, and steps 5 and 6 apply to primary design.

Apply sealing compound to mating surfaces of pipe plug and spindle and allow to dry before applying sealing compound.

- 1 Deleted.
- 2 Deleted.
- 3 Install spindle (2) in arm (3).
- 4 Install eight capscrews (4) and lock wire (5).

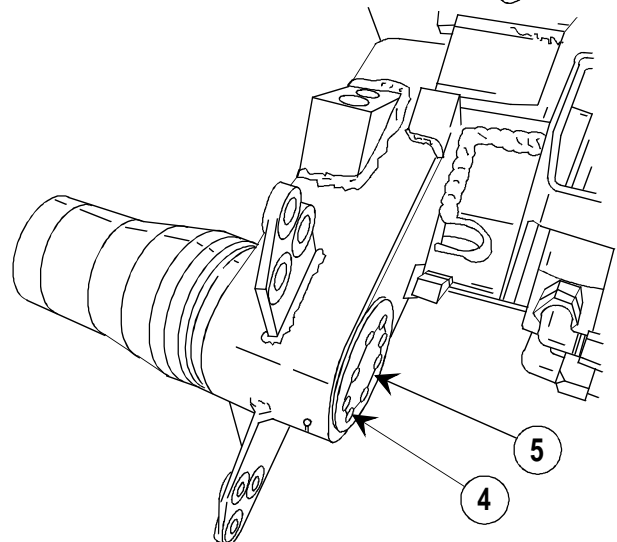
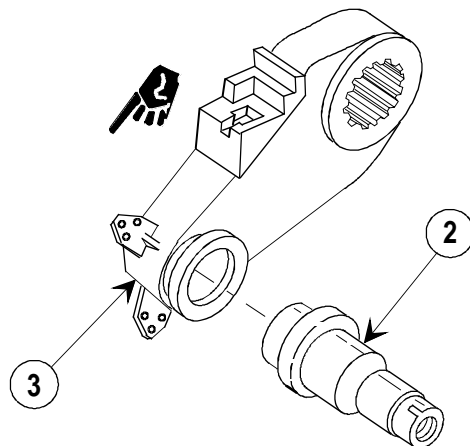

2-48. ARM AND SPINDLE ASSEMBLY—MAINTENANCE INSTRUCTIONS (cont)

REASSEMBLY (cont)

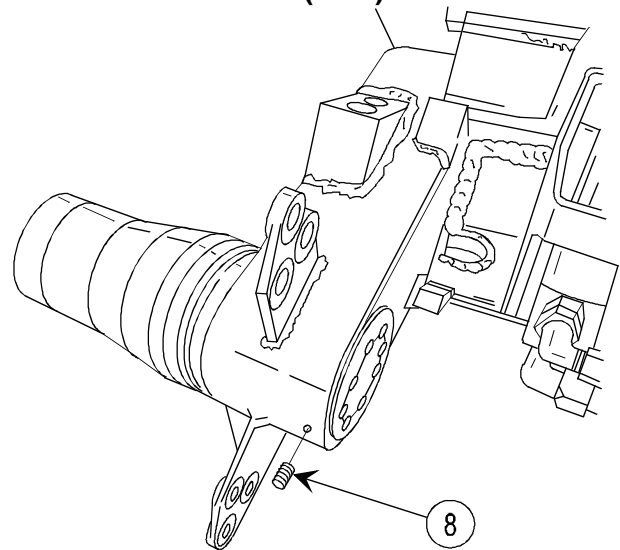
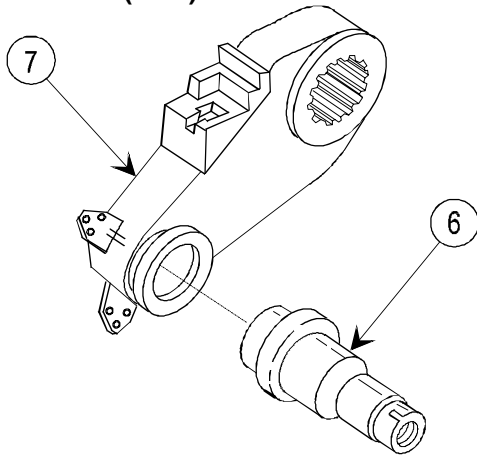

5 Install spindle (6) in arm (7), using hydraulic press (not shown).

6 Coat three setscrews (8) with sealing compound and install. Torque to 50 to 55 ft-lb (68 to 74 N-m).

2-49. BRAKE PRECHECK, HOUSING ASSEMBLY, AND FILTER ASSEMBLY—MAINTENANCE INSTRUCTIONS

THIS TASK COVERS:

a. Removal

b. Inspection/repair

c. Installation

INITIAL SETUP

Tools and Special Tools

Artillery and turret mechanic's ordnance tool kit (SC 5180-95-CL-A12)

Materials/Parts

Lock wire (item 35, appx B)

Tape, antiseizing (item 32, appx B)

References

TM 9-1025-211-10

TM 9-1025-211-20&P

TM 9-1025-211-34P

Equipment Conditions

Emergency and service hose assemblies removed (TM 9-1025-211-20&P)

Air pressure bled from emergency tank (TM 9-1025-211-10)

2-49. BRAKE PRECHECK, HOUSING ASSEMBLY, AND FILTER ASSEMBLY—MAINTENANCE INSTRUCTIONS (cont)

NOTE

All data on page 2-329 deleted.

REMOVAL (cont)

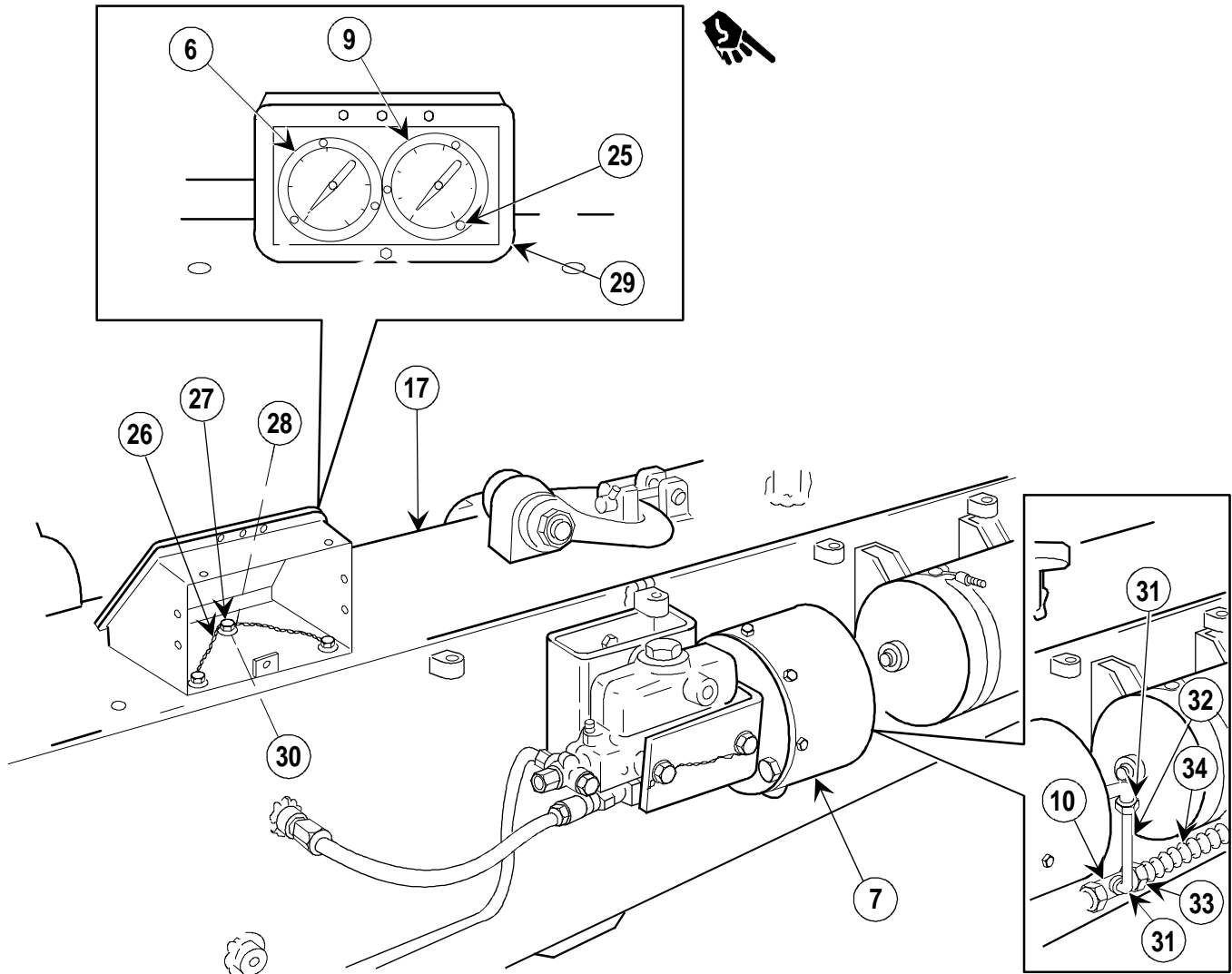

- 9 Remove six screws (25) and two gages (6 and 9).
- 10 Remove lock wire (26), three screws (27), and three lockwashers (28) from right trail (17). Remove housing assembly (29) from right trail (17).

CAUTION

Removing threaded inserts may cause damage. Do not remove unless necessary for replacement of authorized parts.

- 11 Remove seven inserts (30) from trail.
- 12 Loosen two nuts (31) from short tube (32), one nut from elbow on power booster (7) and the second from tee (10).
- 13 Loosen nut (33) from tee (10) securing long tube (34) to tee.
- 14 Deleted.
- 15 Deleted.

NOTE

There are two service and emergency brake line air filters, but procedures are written for one.

- 16 Unscrew nut (42) on adapter (43).
- 17 Remove two self-locking nuts (44) and two lockwashers (45).
- 18 Remove u-bolt (46).
- 19 Remove brake line air filter (47).
- 20 Remove adapter (43) from brake line air filter (47).

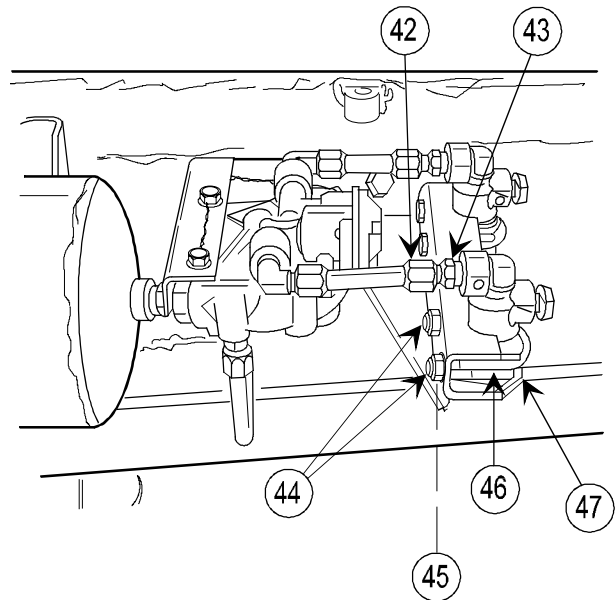

INSPECTION/REPAIR

- 1 Check for broken, damaged, or missing parts.
- 2 Repair is by replacement of authorized parts (TM 9-1025-211-34P).
- 3 Replace brake line air filters if housing is cracked or broken.

**2-49. BRAKE PRECHECK, HOUSING ASSEMBLY, AND FILTER ASSEMBLY—
MAINTENANCE INSTRUCTIONS (cont)**

INSTALLATION

- 1 Wrap threaded end of adapter (1) with antiseizing tape. Install adapter (1) on brake line air filter (2).
- 2 Install brake line air filter (2).
- 3 Connect nut (3) on adapter (1), but do not tighten.
- 4 Install u-bolt (4).
- 5 Install two lockwashers (5) and two self-locking nuts (6), and tighten.
- 6 Tighten nut (3) on adapter (1).

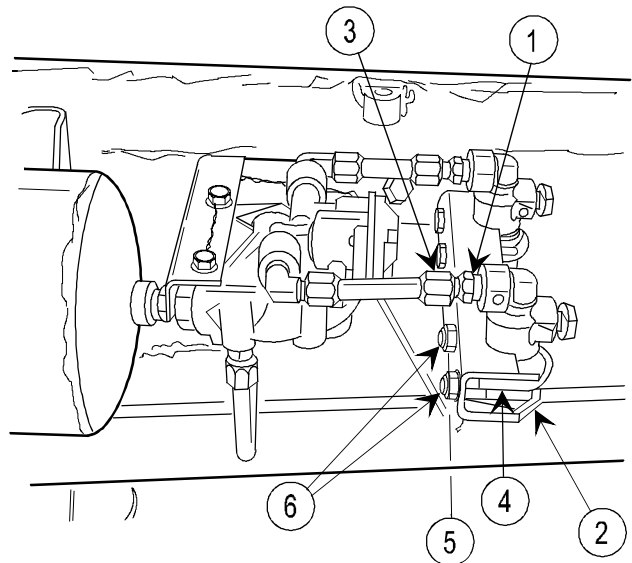

NOTE

There are two service and emergency brake line air filters, but procedures are written for one.

- 7 Check brake line air filter (2) for air leaks (TM 9-1025-211-20&P).

- 8 Deleted.
- 9 Deleted.

NOTE

Steps 10 thru 15 pertain to modified howitzers.

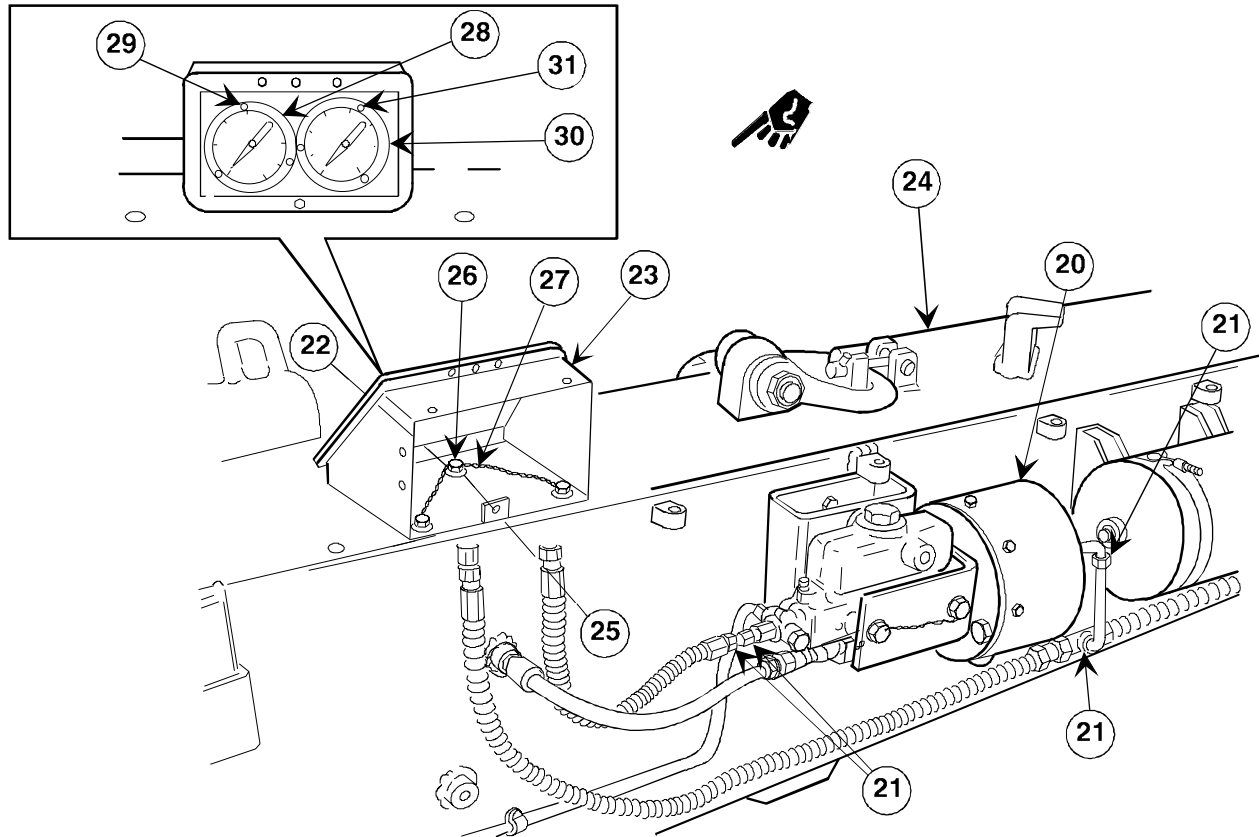

- 10 Deleted.
- 11 Deleted.
- 12 Install seven inserts (22), if removed.
- 13 Position housing (23) on trail (24). Install three washers (25) and three screws (26). Tighten screws (26) and install lock wire (27).
- 14 Position 0- to 3000-psi high pressure gage (28) on left side of housing (closest to power booster (20)) and secure with three screws (29).
- 15 Position 0- to 200-psi low pressure gage (30) on right side of housing (23) and secure with three screws (31).

NOTE
All data on page 2-334 deleted.

**2-50. BOTTOM CARRIAGE ASSEMBLY – REAR BRAKE PARTS EMERGENCY RELAY VALVE—
MAINTENANCE INSTRUCTIONS**

THIS TASK COVERS:

- | | | |
|------------|----------------------|-----------------|
| a. Removal | b. Inspection/repair | c. Installation |
|------------|----------------------|-----------------|

INITIAL SETUP

Tools and Special Tools

Artillery and turret mechanic's ordnance tool kit (SC 5180-95-CL-A12)

Materials/Parts

Lock wire (item 34, appx B)

Lock wire (item 35, appx B)

Tape, antiseizing (item 32, appx B)

References

TM 9-1025-211-10

TM 9-1025-211-20&P

TM 9-1025-211-34P

Equipment Conditions

Trails spread (TM 9-1025-211-10)

Firing assembly baseplate removed from trails (TM 9-1025-211-10)

Emergency and service hose assemblies removed (TM 9-1025-211-20&P)

2-328 Brake line air filters removed

2-328 Cover assembly removed

REMOVAL

- 1 Remove two nuts (1) on two elbows (2).
- 2 Remove tubes (3 and 4) from elbows (2).
- 3 Unscrew nut (5) to disconnect pipe union (6).

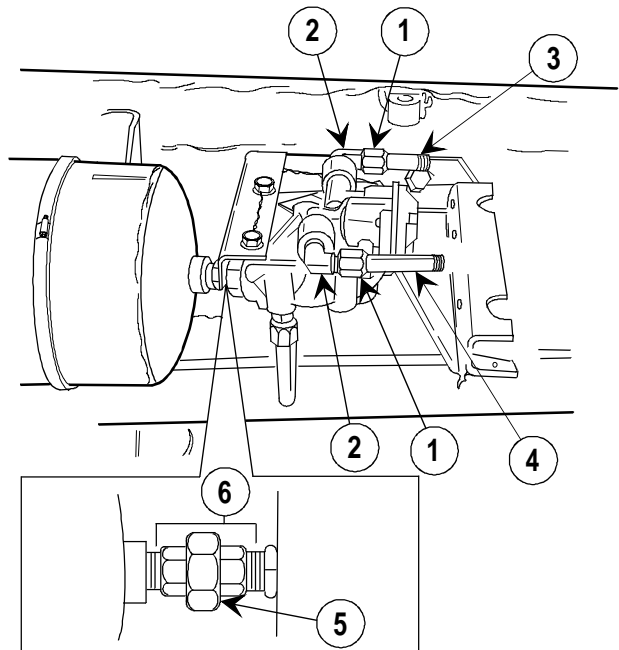

**2-50. BOTTOM CARRIAGE ASSEMBLY – REAR BRAKE PARTS EMERGENCY RELAY VALVE—
 MAINTENANCE INSTRUCTIONS (cont)**

REMOVAL (cont)

- 4 Unscrew nut (7) on adapter (8).
- 5 Remove lock wire (9) and two capscrews (10).
- 6 Remove emergency relay valve (11).
- 7 Remove pipe union (6), nipples (12 and 13), and pipe bushing (14).

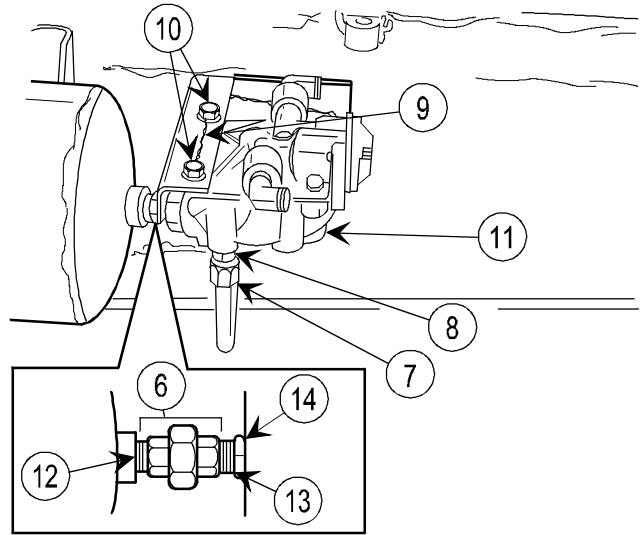

- 8 Remove two elbows (2).
- 9 Remove adapter (8).
- 10 Remove three pipe plugs (15).

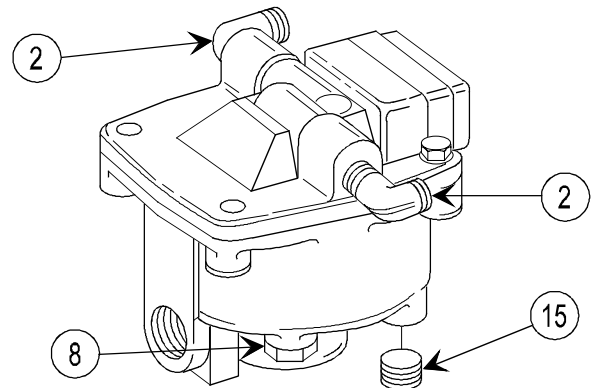

- 11 Remove lock wire, two screws (16), and two lockwashers (17).

NOTE

Perform steps 12 thru 15 only to replace authorized parts (TM 9-1025-211-34P) as required.

- 12 Remove two loop clamps (18).
- 13 Remove tube (19).
- 14 Remove lock wire, four capscrews (20), and four washers (21).
- 15 Remove valve-air cleaner bracket (22).

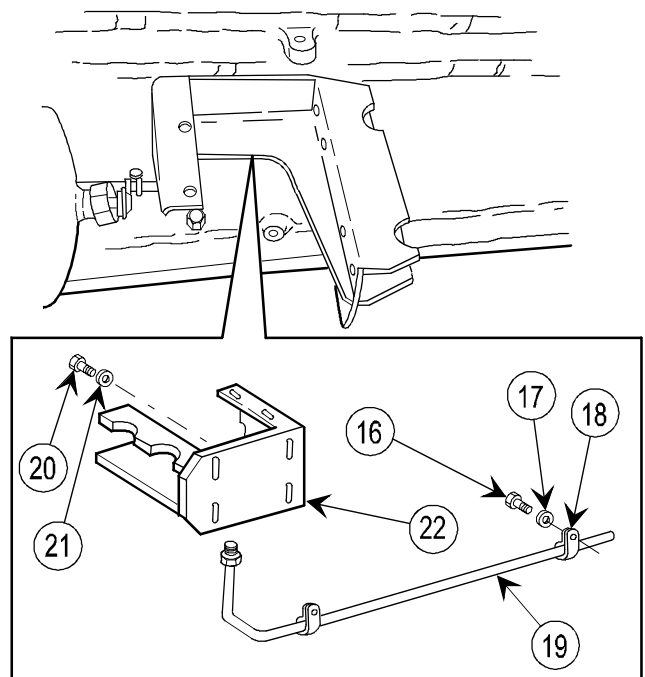

INSPECTION/REPAIR

- 1 Check for broken, damaged, or missing parts.
- 2 Repair is by replacement of authorized parts (TM 9-1025-211-34P).

INSTALLATION

- 1 Install valve air-cleaner bracket (1).
- 2 Install four washers (2), four capscrews (3), and lock wire (item 35, appx B).
- 3 Install two loop clamps (4) on tube (5).

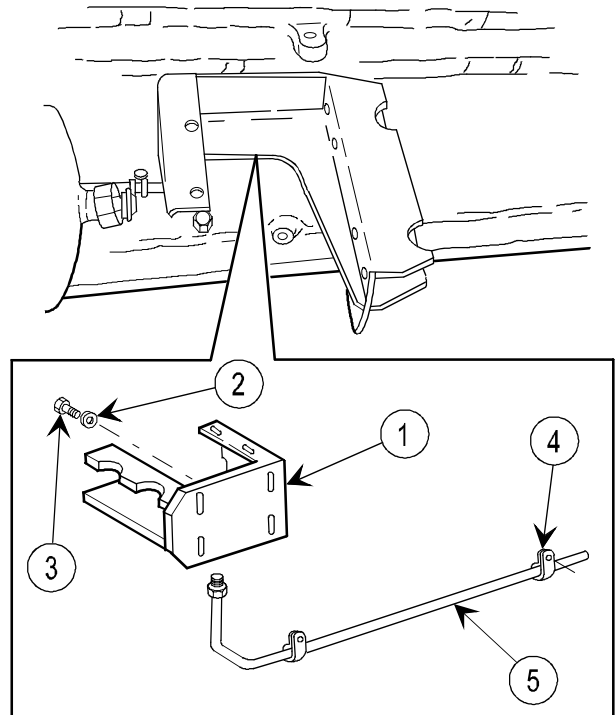

- 4 Install two lockwashers (6), two screws (7), and lock wire (8) (item 34, appx B) on loop clamps (4).

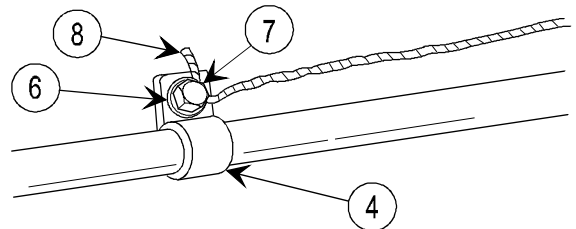

NOTE

Wrap all pipe threads with antiseizing tape at assembly.

- 5 Install three pipe plugs (9).
- 6 Install adapter (10) and two elbows (11).
- 7 Install pipe bushing (12) and pipe nipples (13 and 14) in emergency relay valve (15) and air pressure tank (16).
- 8 Install one half pipe union (17) on pipe nipple (14) and one half of pipe union (17) on pipe nipple (13).
- 9 Loosen two hose clamps (18).

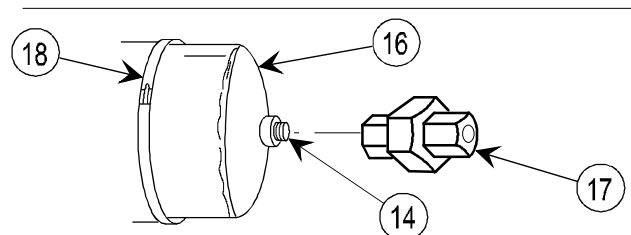
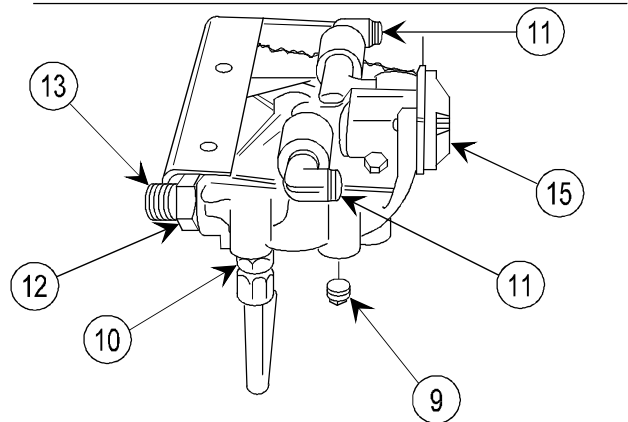

**2-50. BOTTOM CARRIAGE ASSEMBLY – REAR BRAKE PARTS EMERGENCY RELAY VALVE—
MAINTENANCE INSTRUCTIONS (cont)**

INSTALLATION (cont)

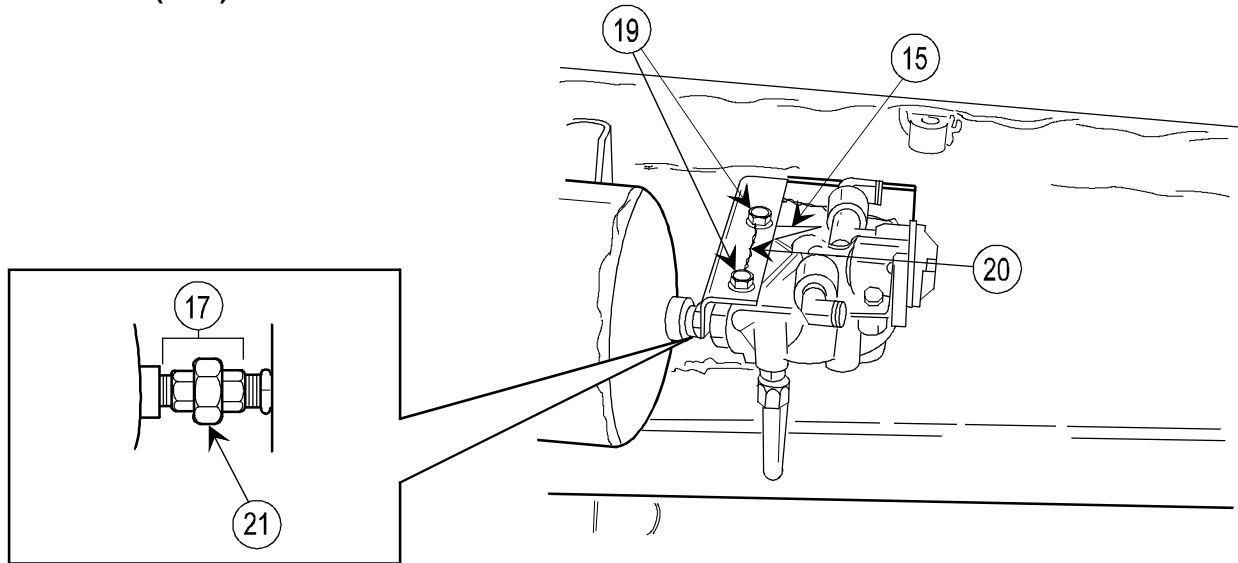

- 10 Install emergency relay valve (15).
- 11 Install two capscrews (19) and lock wire (20) (item 35, appx B).
- 12 Connect pipe union (17) with nut (21) and tighten.

- 13 Tighten two hose clamps (18).
- 14 Install tube (5) in adapter (10).
- 15 Tighten nut (22) on adapter (10).
- 16 Install tubes (23 and 24).
- 17 Install two nuts (25) on two elbows (11).
- 18 Test emergency relay valve (15) (TM 9-1025-211-20&P) after reinstalling brake line air filters and hoses.

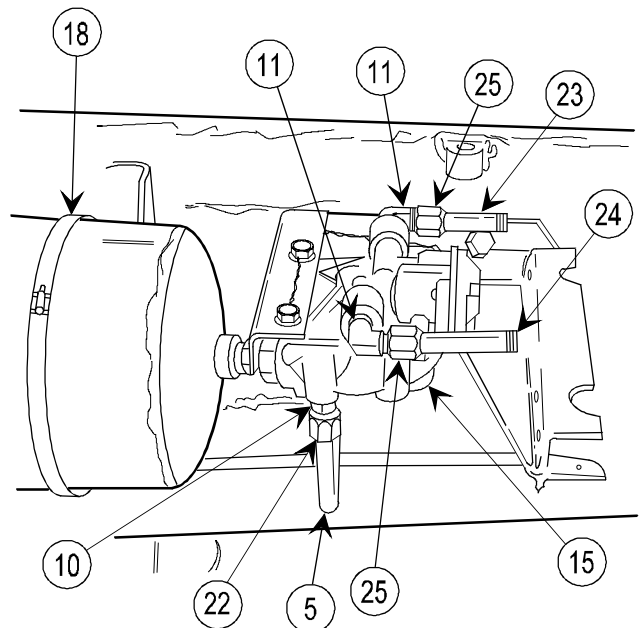

2-51. AIR PRESSURE TANK—MAINTENANCE INSTRUCTIONS (cont)

INSPECTION/REPAIR

- 1 Check for broken, damaged, or missing parts.
- 2 Repair is by replacement of authorized parts (TM 9-1025-211-34P).

NOTE

Air pressure tank may have one or more ports closed with pipe plugs. These plugs are not authorized for replacement, but may be removed if necessary to reseal with antiseizing tape.

INSTALLATION

- 1 Install two air tank brackets (1), four capscrews (2), and lock wire.

NOTE

Wrap all pipe threads with antiseizing tape at assembly.

- 2 Install pipe nipple (3) and half of pipe union (4) in air pressure tank (5).
- 3 Install two hose clamps (6) on air pressure tank (5). Install air pressure tank through air tank brackets (1), but do not tighten hose clamps.
- 4 Install elbow (7) and adapter (8).
- 5 Install tube (9) and tighten two nuts (10).
- 6 Connect pipe union (4) with nut (11) and tighten.
- 7 Tighten two hose clamps (6).
- 8 Install drain cock (12).

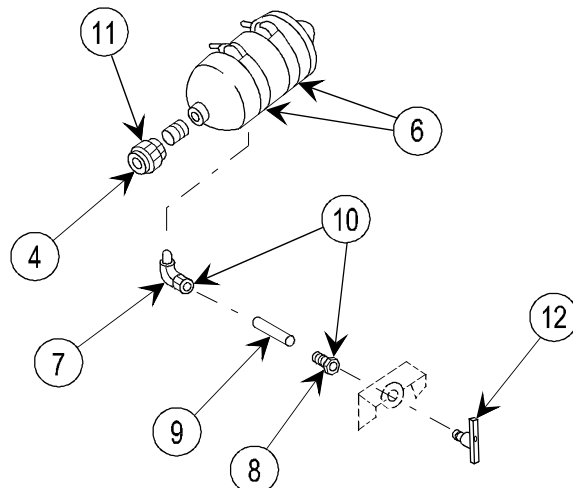
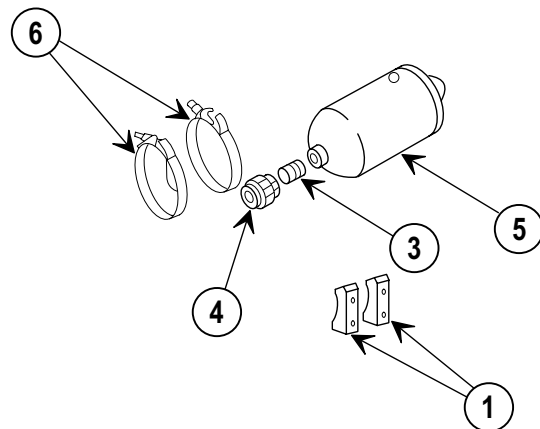
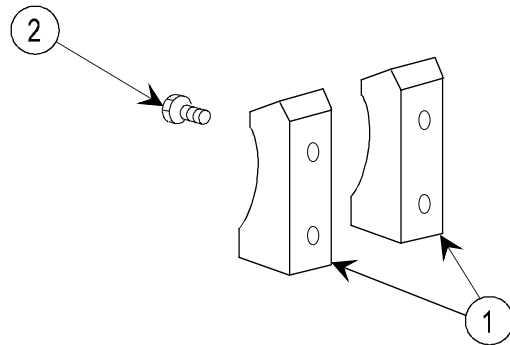

2-52. POWER BOOSTER ASSEMBLY—MAINTENANCE INSTRUCTIONS

THIS TASK COVERS:

- | | | |
|---------------|-----------------|----------------------|
| a. Removal | b. Disassembly | c. Inspection/repair |
| d. Reassembly | e. Installation | f. Service |

INITIAL SETUP

Tools and Special Tools

Artillery and turret mechanic's ordnance tool kit (SC 5180-95-CL-A12)

Materials/Parts

Brake fluid (item 5, appx B)
Cleaning compound (item 7, appx B)
Lock wire (item 35, appx B)
Lock wire (item 40, appx B)
Preformed packing (MS28778-5)
Tape, antiseizing (item 32, appx 8)
Wiping rag (item 22, appx B)

NOTE

Disposal of hydraulic fluid must be in accordance with local, state, and federal regulation.

References

TM 9-1025-211-10
TM 9-1025-211-20&P
TM 9-1025-211-34P

Equipment Conditions

2-328 Brake precheck parts removed from power booster (modified howitzers)
2-328 Cover assembly removed
Firing assembly baseplate removed from trails (TM 9-1025-211-10)
Trails spread (TM 9-1025-211-10)
Unit parts removed (TM 9-1025-211-20&P)
Air filter and brake parts removed as required (TM 9-1025-211-20&P)
Snorkel filter removed (TM 9-1025-211-20&P)

REMOVAL

- 1 Disconnect tube (1) by unscrewing nut (2) and drain fluid into suitable container.

2-52. POWER BOOSTER ASSEMBLY—MAINTENANCE INSTRUCTIONS (cont)

REMOVAL (cont)

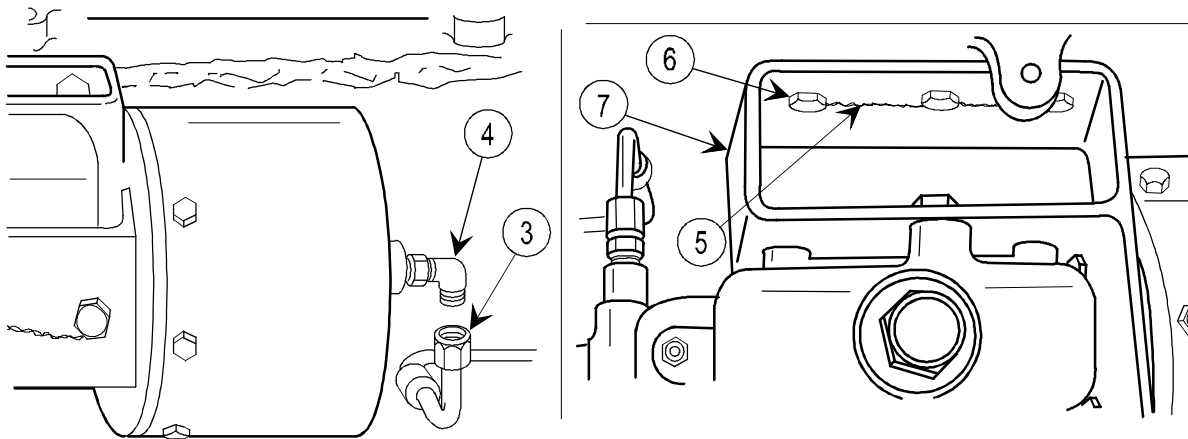

- 2 Disconnect nut (3) from elbow (4) on howitzers that have not been modified. For modified howitzers, disconnect nut (3) from tee (10) (page 3-330).
- 3 Remove lock wire (5) and three capscrews (6).
- 4 Remove power booster assembly (7).
- 5 Remove elbow (4).

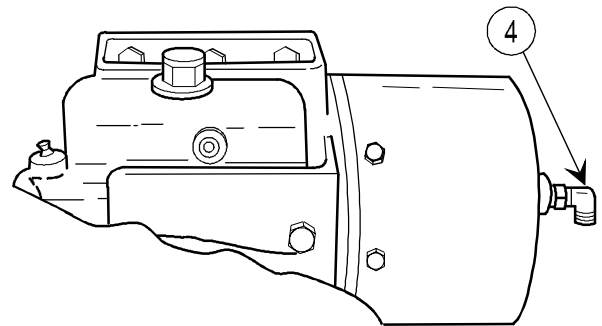

DISASSEMBLY

- 1 Remove adapter (1) and preformed packing (2).
- 2 Remove lock wire, three capscrews (3), and bracket (4).
- 3 Remove lock wire and two capscrews (5).
- 4 Remove pipe bushing (6).

NOTE

Avoid damaging seal grooves and cylinder bore, as defects on these surfaces will cause leakage. Also, take particular care to wash these areas with cleaning compound. Air dry or dry with lint-free wiping rag.

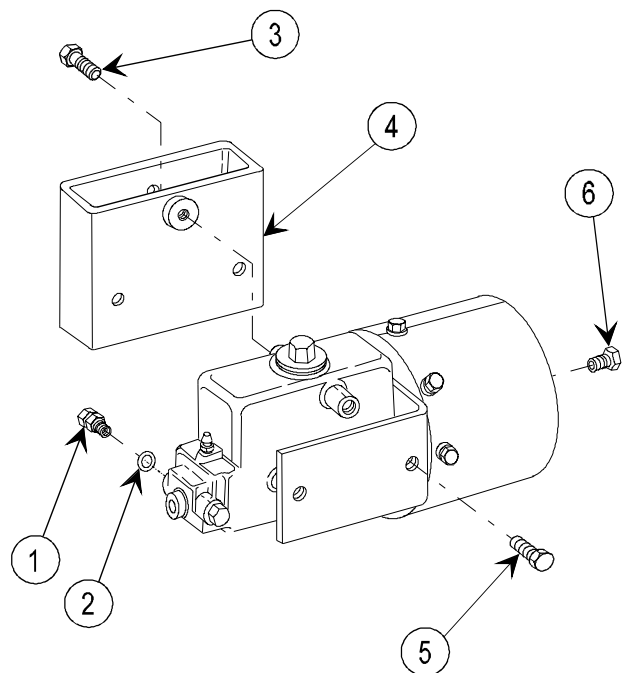

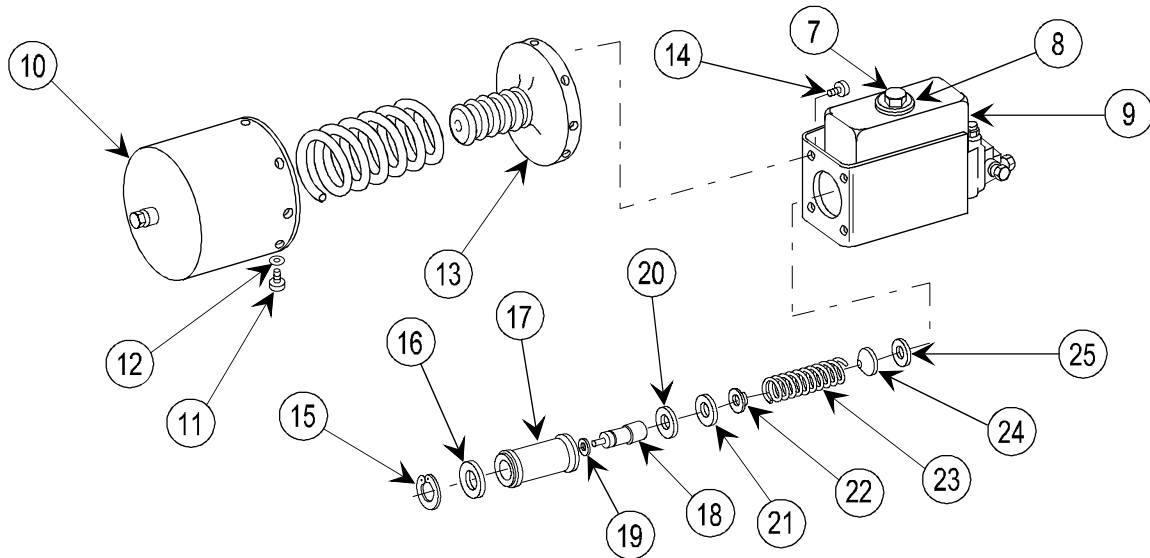

- 5 Remove filler cap (7) and gasket (8) and drain all fluid from master cylinder (9).

CAUTION

Air cylinder (10) is under spring tension.

- 6 Remove eight capscrews (11) and eight lockwashers (12).
- 7 Separate air cylinder (10) from master cylinder (9).

NOTE

Mark end plate (13) and master cylinder (9) before disassembly to ensure proper alignment during reassembly.

- 8 Remove four capscrews (14) from master cylinder (9) and end plate (13), and remove end plate (13).
- 9 Remove retainer ring (15) from groove in end of master cylinder (9).

NOTE

Spacer (16) could be rusted to the master cylinder (9); if so, tap against face of spacer (16) with a brass punch to jar spacer (16) free.

- 10 Remove spacer (16) from master cylinder (9).

CAUTION

Main piston (17) is under spring tension.

- 11 Remove main piston (17) from master cylinder (9).
- 12 Remove secondary piston (18) from main piston (17).
- 13 Remove preformed packing (19) from secondary piston (18).
- 14 Remove back-up washer (20), primary cup (21), spring cup seat (22), spring coil (23), residual check valve (24) (note the direction the valve is facing when removing), and valve seat (25).

2-52. POWER BOOSTER ASSEMBLY—MAINTENANCE INSTRUCTIONS (cont)

INSPECTION/REPAIR

- 1 Check for broken, damaged, or missing parts.
- 2 Repair is by replacement of authorized parts (TM 9-1025-211-34P).
- 3 Lubricate all parts with brake fluid.

REASSEMBLY

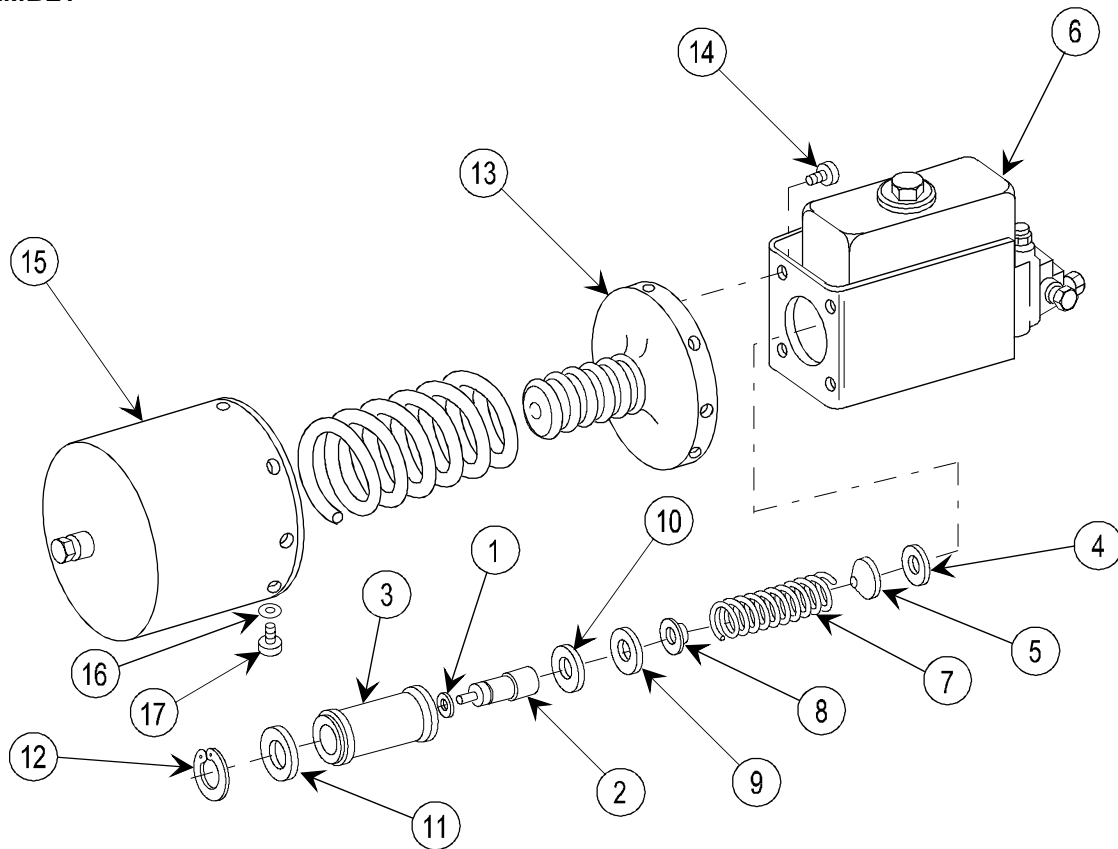

- 1 Install new preformed packing (1) on secondary piston (2).
- 2 Install secondary piston (2) into main piston (3).
- 3 Install valve seat (4) and residual check valve (5) onto the seating at the end of master cylinder (6) bore. Make sure check valve (5) is facing the correct direction.
- 4 Install spring coil (7) and spring cup seat (8) into master cylinder (6).
- 5 Install primary cup (9) and back-up washer (10). Ensure they are properly seated on the spring (7).
- 6 Carefully insert main piston (3) into master cylinder (6).
- 7 Install spacer (11) to its proper location and apply inward pressure until retainer ring (12) can be properly seated in groove. Make sure it is properly seated, and that main piston (3) returns against spacer (11).

- 8 Assemble end plate (13) to master cylinder (6).
- 9 Install four capscrews (14) through master cylinder (6) and into threaded holes in end plate (13).
- 10 Reassemble air cylinder (15) to master cylinder (6), and install and tighten lockwashers (16) and eight capscrews (17).

- 11 Wrap threads of pipe bushing (18) with antiseizing tape and install pipe bushing (18).

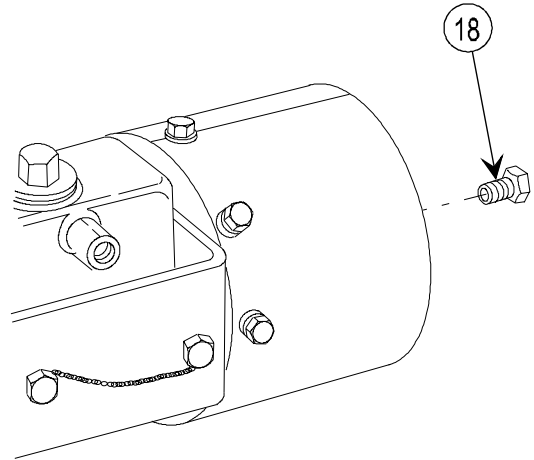

- 12 Install two capscrews (19) and lock wire (item 35, appx B) in master cylinder (6) through bracket (20).
- 13 Install bracket (21), three capscrews (22), and lock wire (item 40, appx B).
- 14 Install new preformed packing (23) and adapter (24).

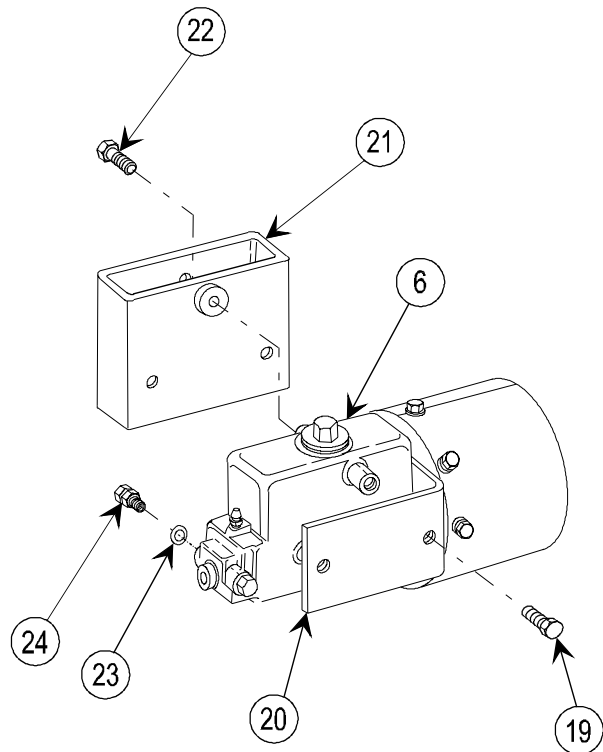

2-52. POWER BOOSTER ASSEMBLY—MAINTENANCE INSTRUCTIONS (cont)

INSTALLATION

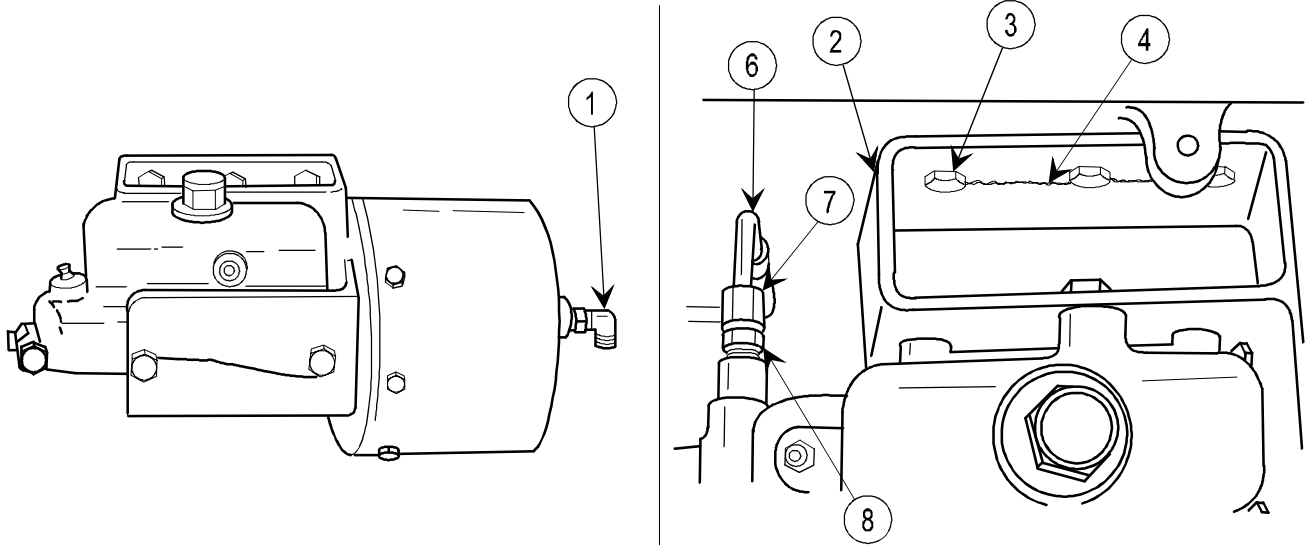

- 1 Wrap threads of elbow (1) with antiseizing tape and install.
- 2 Aline holes in power booster assembly (2) with holes in trail.
- 3 Install three capscrews (3) and lock wire (4) (item 35, appx B).
- 4 Install nut (5) on elbow (1) (unmodified howitzers). On modified howitzers, install nut (5) to tee (17) (page 2-333).
- 5 Connect tube (6) by screwing nut (7) on to adapter (8).
- 6 Bleed power booster assembly (2) and refill with brake fluid (TM 9-1025-211-20&P).

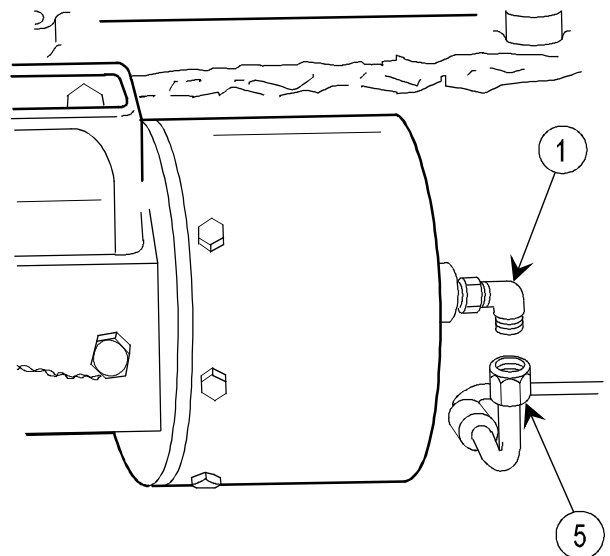

SERVICE

- 1 Remove filler cap from master cylinder.
- 2 Check fluid in master cylinder for contamination. If contaminated, replace hydraulic fluid in the entire system.
- 3 Remove master cylinder (p 2-341).

WARNING

Cleaning solvent is toxic and flammable. Use in well-ventilated area. Avoid breathing the vapors and keep away from ignition sources.

- 4 Drain hydraulic fluid from master cylinders and clean using cleaning compound.
- 5 Attach bleeder line to each wheel cylinder bleeder valve, open bleeder valves, and blow compressed air through all hydraulic lines. This is done to clear all contaminants from the brake system.
- 6 Reassemble the hydraulic cylinder and lines.
- 7 Add brake fluid and purge/bleed the brake system (TM 9-1025-211-20&P).

NOTE

All data on pages 2-347 through 2-353 deleted.

2-54. GUN TUBE TRAVEL LOCK—MAINTENANCE INSTRUCTIONS

THIS TASK COVERS:

- | | | |
|---------------|-----------------|----------------------|
| a. Removal | b. Disassembly | c. Inspection/repair |
| d. Reassembly | e. Installation | |

INITIAL SETUP

Tools and Special Tools

Artillery and turret mechanic's ordnance tool kit (SC 5180-95-CL-A12)
Welder

Materials/Parts

Abrasive cloth (item 8, appx B)
Adhesive (item 3, appx B)
Cleaning compound (item 7, appx B)
Cotter pin (7) (MS24665-353)
Friction lining (2) (12008669)
Paint (CARC) (items 16, 17, 18, appx B)
Paint remover (CARC) (item 24, appx B)
Primer (CARC) (item 21, appx B)
Primer (item 20, appx B)
Wiping rag (item 22, appx B)

References

TB 9-1025-211-34
TM 9-1025-211-34P
TM 43-0139

REMOVAL

WARNING

For safety precautions, prior to beginning any painting operations refer to TM 43-0139. Improper application or removal of CARC paint can be extremely hazardous to your health.

CAUTION

Gun tube travel lock (1) is welded to left trail assembly (2) and should not be removed unless necessary for replacement of authorized parts. Use care to prevent damage to trail.

Remove gun tube travel lock (1) from left trail assembly (2) by cutting and grinding as required.

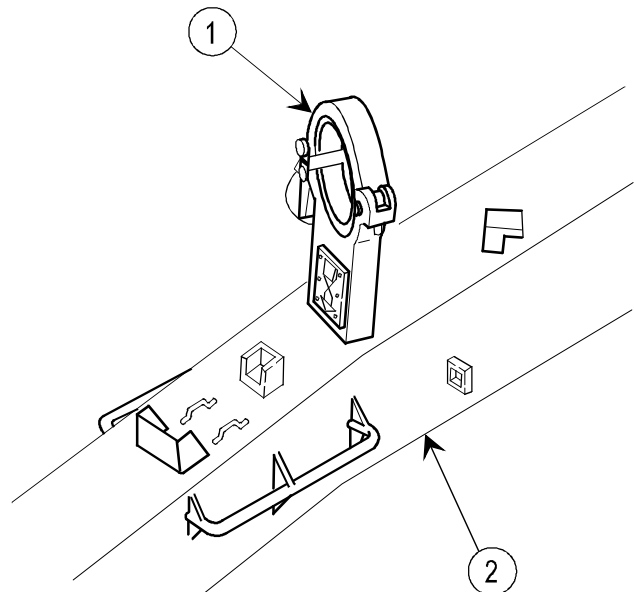

DISASSEMBLY

NOTE

Disassembly can be performed without removing gun tube travel lock.

- 1 Remove pin cable assembly (1) with attached parts.
- 2 Remove four cotter pins (2) and four washers (3).
- 3 Remove two rigid connecting links (4).
- 4 Remove two pins (5) and lock-release lever (6).

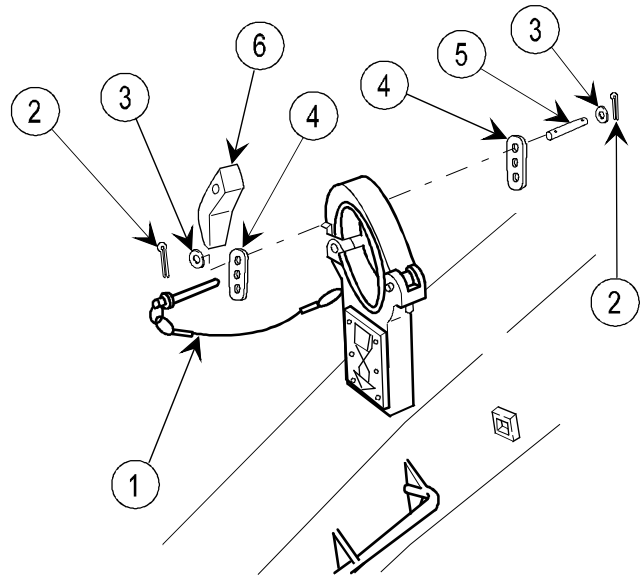

- 5 Remove two cotter pins (7) and two washers (8).
- 6 Remove pin (9).
- 7 Remove gun tube locking clamp (10).
- 8 Remove cotter pin (11), nut (12), and eyebolt (13).
- 9 Remove two friction linings (14) from saddle (15) by scraping off.
- 10 Remove six screws (16), six washers (17), and plate (18) (modified howitzers only).

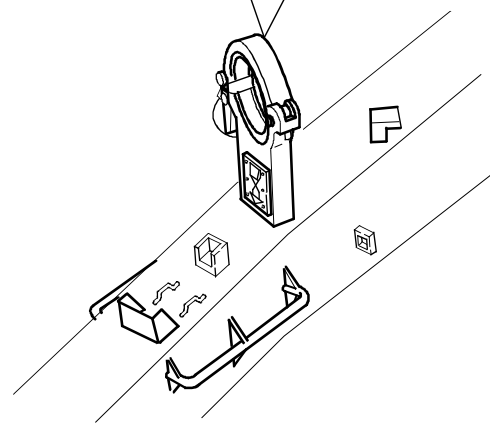
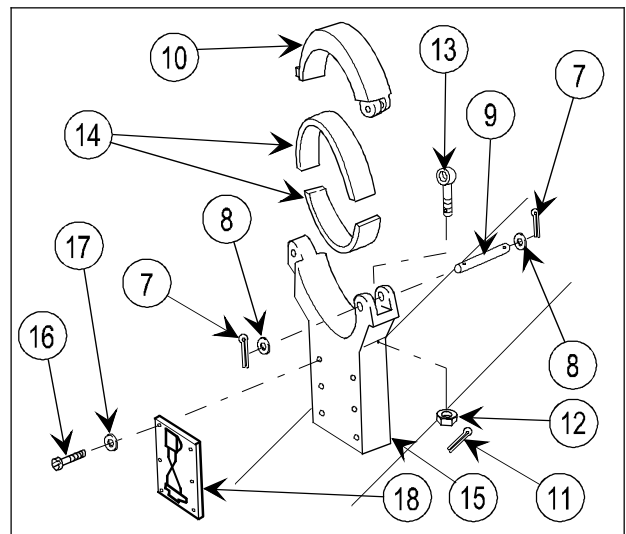

INSPECTION/REPAIR

- 1 Check for broken, damaged, or missing parts.
- 2 Repair by replacement of authorized parts (TM 9-1025-211-34P).

2-54. GUN TUBE TRAVEL LOCK—MAINTENANCE INSTRUCTIONS (cont)

REASSEMBLY

- 1 Clean gun tube locking clamp (1) and saddle (2) thoroughly with cleaning compound and abrasive cloth.
- 2 Install eyebolt (3) and nut (4) loosely.
- 3 Install gun tube locking clamp (1).
- 4 Install pin (5).
- 5 Install two washers (6) and two new cotter pins (7).
- 6 Install lock-release lever (8), two pins (9), and two rigid connecting links (10).
- 7 Install four washers (11) and four new cotter pins (12).
- 8 Install pin cable assembly (13) with attached parts.
- 9 Align plate (14) with holes on saddle (2). Install six screws (15) and six washers (16) (modified howitzers only).
- 10 Apply adhesive to two new friction linings (17) and install on gun tube locking clamp (1) and saddle (2).
- 11 Open gun tube travel lock (18), and rest cannon tube (19) on saddle (2). Close and lock gun tube travel lock (18).
- 12 Tighten nut (4) and back off to align hole for cotter pin (20).
- 13 Install new cotter pin (20).

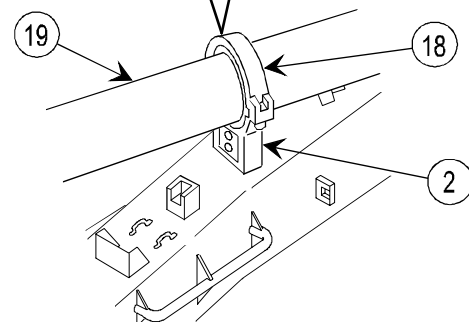
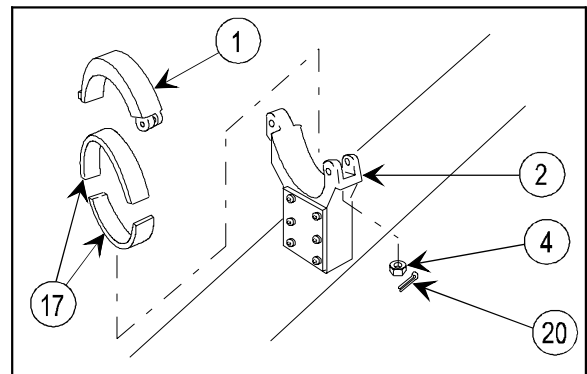
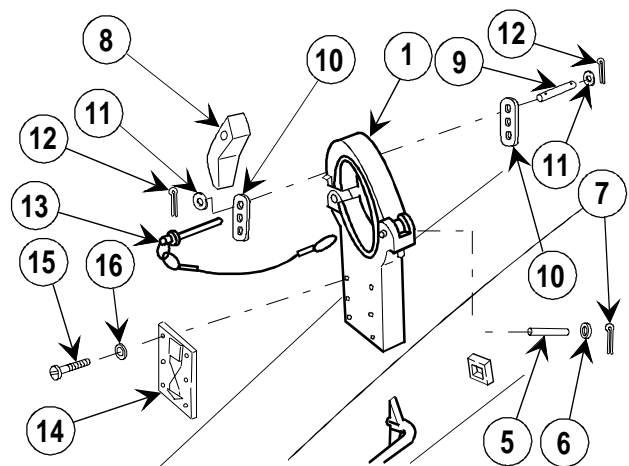
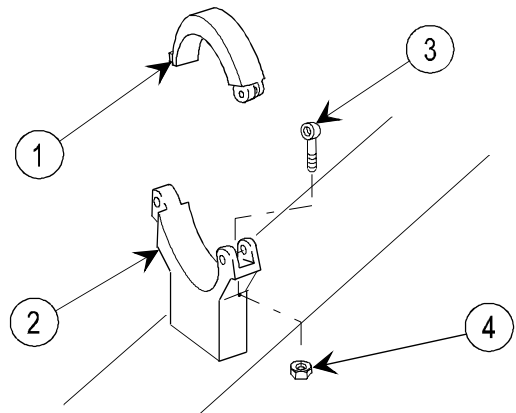

INSTALLATION

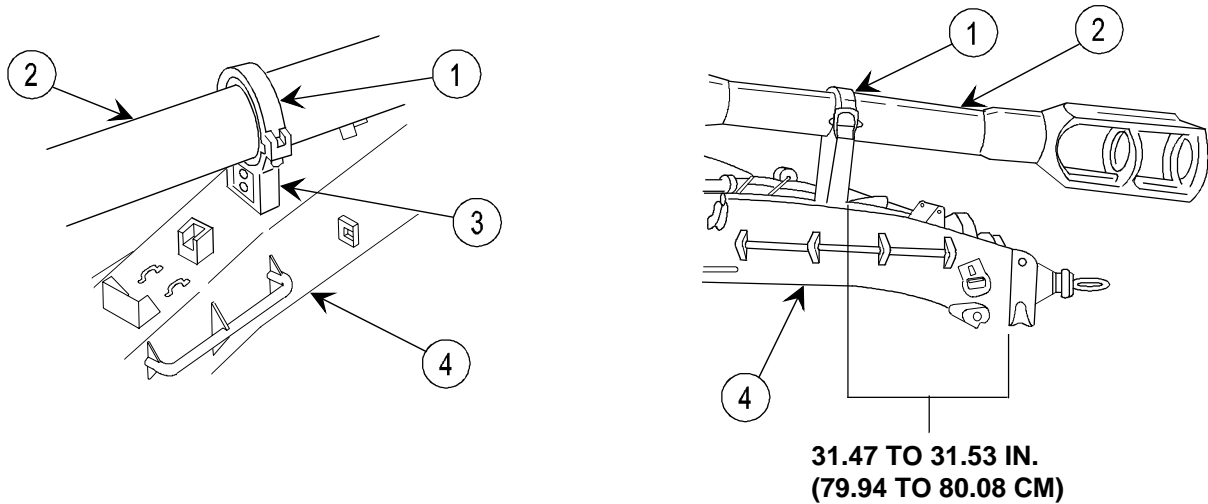

- 1 Position gun tube travel lock (1) on cannon tube (2).
- 2 Traverse, elevate, and/or depress cannon tube (2) as required to position gun tube travel lock (1) with corner (3) 0.22 to 0.28 in. (0.56 to 0.71 cm) in from outside edge and 31.47 to 31.53 in. (79.94 to 80.08 cm) from the end of left trail assembly (4).

WARNING

For safety precautions, prior to beginning any painting operations refer to TM 43-0139. Improper application or removal of CARC paint can be extremely hazardous to your health.

Cleaning solvent is toxic and flammable. Use in well-ventilated area. Avoid breathing the vapors and keep away from ignition sources.

Local safety welding procedures must be followed when performing welding operation.

NOTE

Clean with cleaning compound and wiping rag. After welding, spot paint as required.

- 3 Weld gun tube travel lock (1) to left trail assembly (4) (TB 9-1025-211-34).

2-55. TRAVERSE STOP—MAINTENANCE INSTRUCTIONS

THIS TASK COVERS:

- | | | |
|---------------|-----------------|----------------------|
| a. Removal | b. Disassembly | c. Inspection/repair |
| d. Reassembly | e. Installation | |

INITIAL SETUP

Tools and Special Tools

Artillery and turret mechanic's ordnance tool kit (SC 5180-95-CL-A12)

Materials/Parts

Lock wire (item 34, appx B)

Lock wire (item 35, appx B)

References

TM 9-1025-211-34P

2-55. TRAVERSE STOP—MAINTENANCE INSTRUCTIONS (cont)

REMOVAL

- 1 Remove lock wire (1), bolt (2), and washer (3).
- 2 Remove lock wire (4), bolt (5), and washer (6).
- 3 Remove traverse stop (7).

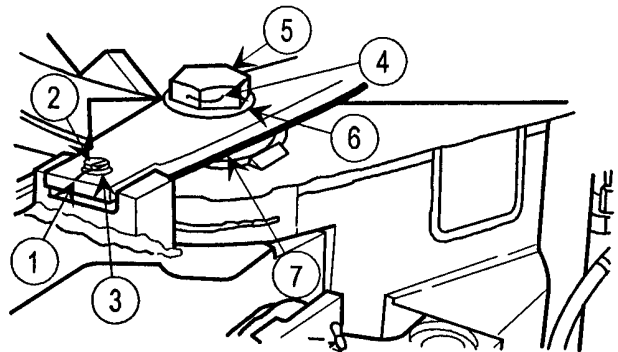

DISASSEMBLY

- 1 Remove sleeve bushing (1) from arm (2).
- 2 Remove two capscrews (3) and spacer plate (4).

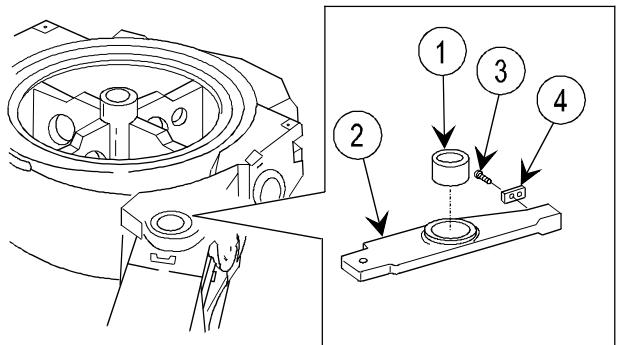

INSPECTION/REPAIR

- 1 Check for broken, damaged, or missing parts.
- 2 Repair is by replacement of authorized parts (TM 9-1025-211-34P).

REASSEMBLY

- 1 Install spacer plate (1) and two capscrews (2).
- 2 Install sleeve bushing (3) in arm (4).

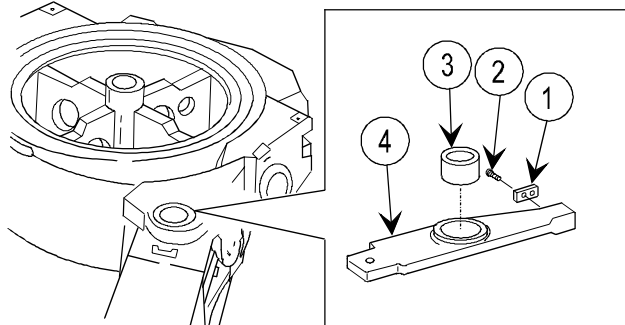

INSTALLATION

- 1 Install traverse stop (1).
- 2 Install washer (2), bolt (3), and lock wire (4) (item 35, appx B).
- 3 Install washer (5), bolt (6), and lock wire (7) (item 34, appx B).

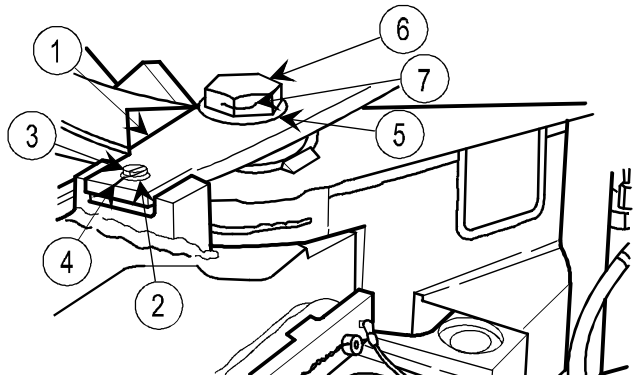

2-56. LEFT CLEVIS ASSEMBLY—MAINTENANCE INSTRUCTIONS

THIS TASK COVERS:

- | | | |
|----------------------|-----------------|----------------|
| a. Inspection/repair | b. Removal | c. Disassembly |
| d. Reassembly | e. Installation | |

INITIAL SETUP

Tools and Special Tools

Artillery and turret mechanic's ordnance tool kit (SC 5180-950-CL-A12)

Materials/Parts

Cotter pin (MS24665-491)
Lock wire (item 35, appx B)

References

TM 9-1025-211-34P

INSPECTION/REPAIR

- 1 Check for broken, damaged, or missing parts.
- 2 Inspect left clevis assembly (1) to see if it is bent and does not align with bracket (2) on bottom carriage assembly (3).
- 3 Repair is by replacement of authorized parts (TM 9-1025-211-34P).

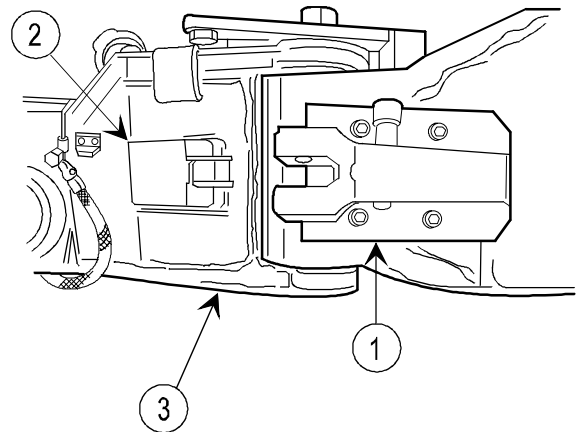

REMOVAL

- 1 Remove cotter pin (1), two links (2), pin cable assembly (3), and tapered plug (4).

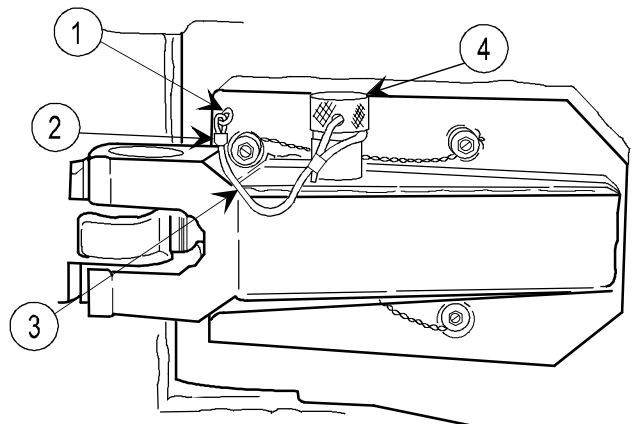

2-56. LEFT CLEVIS ASSEMBLY—MAINTENANCE INSTRUCTIONS (cont)

REMOVAL (cont)

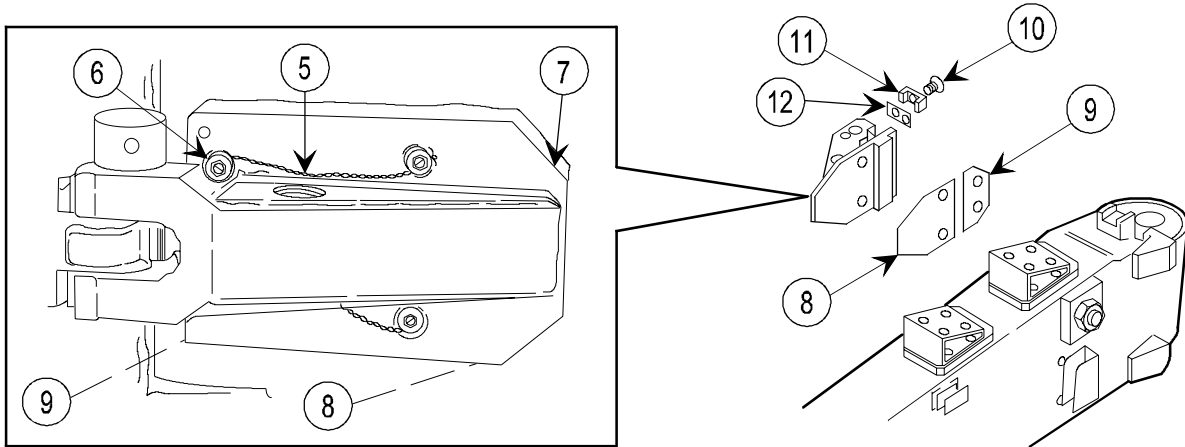

- 2 Remove lock wire (5) and four bolts (6).
- 3 Remove left clevis assembly (7).
- 4 Remove four shims (8).

- 5 Remove four shims (9).
- 6 Remove four screws (10).
- 7 Remove two wear plates (11) and two shims (12).

DISASSEMBLY

Remove lock wire and sleeve bushings (1 and 2) from clevis (3).

REASSEMBLY

Install sleeve bushings (1 and 2) in clevis (3), and install lock wire.

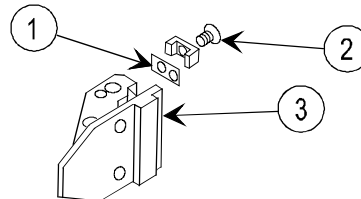
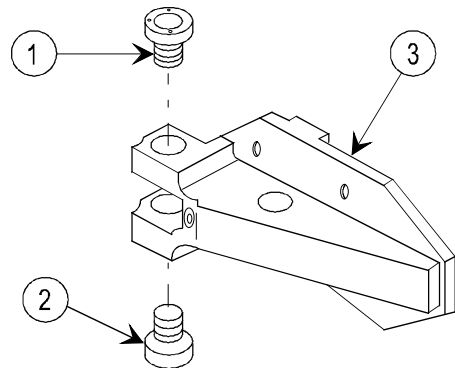

INSTALLATION

- 1 Install two wear plates (1) and four screws (2) on left clevis assembly (3) without shims.

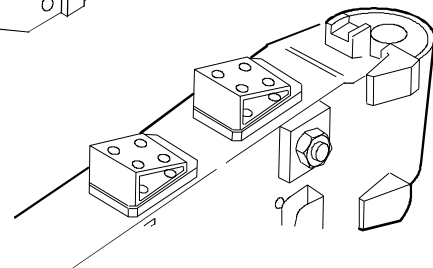

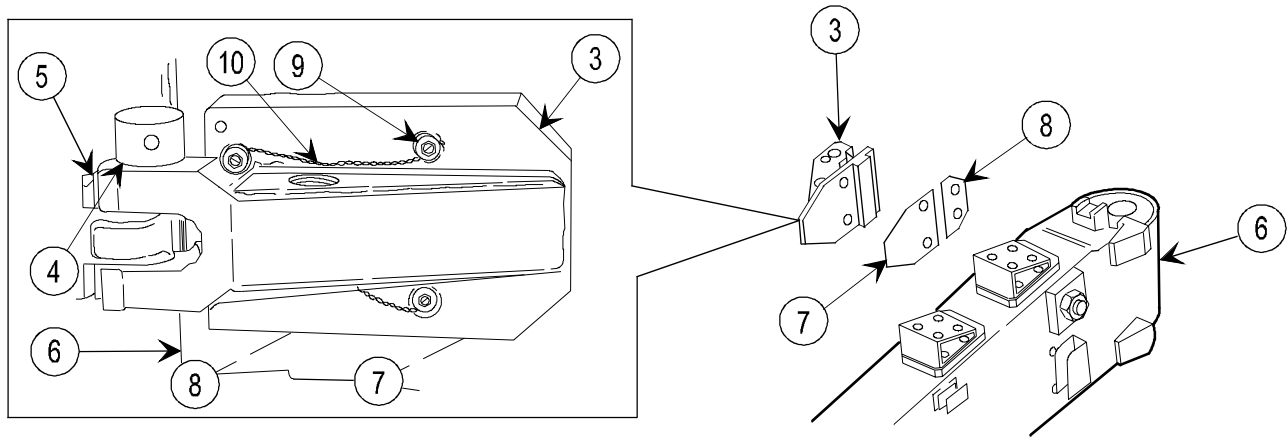

- 2 Install left clevis assembly (3) and tapered plug (4) on bracket (5).
- 3 Open left trail assembly (6) until key on back of left clevis assembly (3) is aligned with slot on left trail assembly (6).

NOTE

Shims (7 and 8) must be adjusted to provide continuous contact with left trail assembly (6) and left clevis assembly (3) when installed.

- 4 Install shims (7 and 8), left clevis assembly (3), four bolts (9), and lock wire (10) on left trail assembly (6).

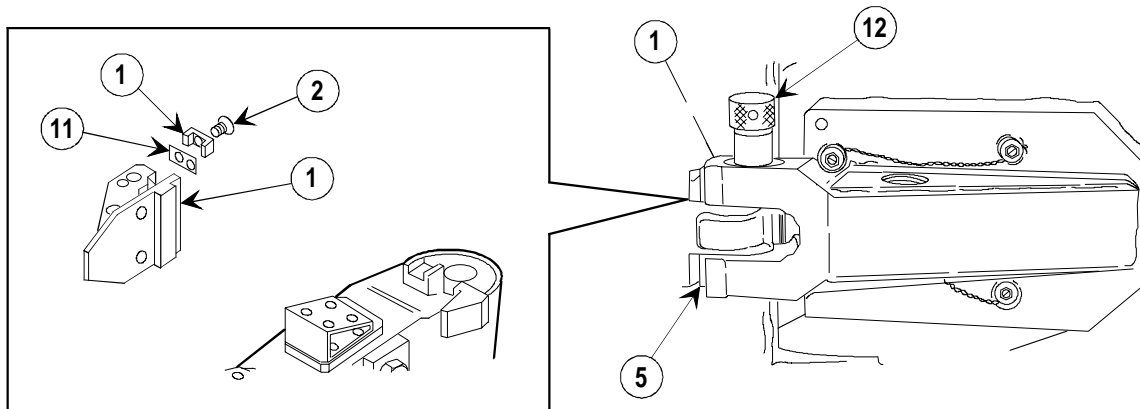

NOTE

Shims (11) must be adjusted to allow 0.000- to 0.002-in. (0.00- to 0.05-mm) clearance between bracket (5) and wear plates (1) with tapered plug (12) installed.

- 5 Adjust thickness of two shims (11) as required.
- 6 Remove tapered plug (12) and move left trail assembly as required to provide access to screws (2).
- 7 Remove four screws (2) and two wear plates (1).
- 8 Install two shims (11), two wear plates (1), and four screws (2).

2-56. LEFT CLEVIS ASSEMBLY—MAINTENANCE INSTRUCTIONS (cont)

INSTALLATION (cont)

- 9 Install tapered plug (12) in stowed position on left clevis assembly (3).
- 10 Install new cotter pin (13).
- 11 Install pin cable assembly (14) and two links (15).

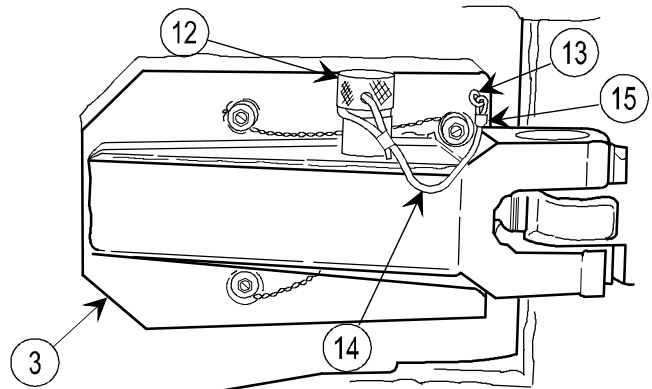

2-57. LEFT TRAIL ASSEMBLY—MAINTENANCE INSTRUCTIONS

THIS TASK COVERS:

- | | | |
|---------------|-----------------|----------------------|
| a. Removal | b. Disassembly | c. Inspection/repair |
| d. Reassembly | e. Installation | f. Service |

INITIAL SETUP

Tools and Special Tools

- Artillery and turret mechanic's ordnance tool kit (SC 5180-95-CL-A12)
- Artillery field maintenance shop equipment (SC 4933-95-CL-A12)
- M198 repairman field artillery tool kit (5911278)

Materials/Parts

- Cotter pin (2) (MS24665-421)
- Cotter pin (2) (MS24665-423)
- Primer (item 19, appx B)
- Spade bracket parts kit (12009201)
- Tape, antiseizing (item 32, appx B)
- WTR grease (item 11, appx B)

Personnel Required: 3

References

- TB 9-1025-211-34
- TM 9-1025-211-10
- TM 9-1025-211-20&P
- TM 9-1025-211-34P

Equipment Conditions

- Basic issue items removed from left trail assembly (TM 9-1025-211-10)
- Travel lock assembly stowed (TM 9-1025-211-10)
- Trails spread far enough to remove firing assembly baseplate (TM 9-1025-211-10)
- Firing assembly baseplate removed (TM 9-1025-211-10)
- Handbrakes engaged (TM 9-1025-211-10)
- Gun carriage spades removed (TM 9-1025-211-20&P)
- Gun assembly (GA) brackets and hardware removed (TM 9-1025-211-20&P)
- 2-359 Left clevis assembly removed
- 2-354 Gun tube travel lock removed if replacing left trail

General Safety Instructions

WARNING

Local safety welding procedures must be followed when performing welding operation.

REMOVAL

NOTE

Some of the removal procedures for the left trail assembly are the same as for the right trail assembly. Perform steps 1 thru 16 (p 2-370) for removal of the trail assembly with attached parts. (Left trail assembly consists of the left trail and threaded inserts only.) Perform steps 17 thru 26, 30 and 31, and 39 thru 51 for removal of attached parts as well as the following steps that pertain to the left trail only. For service procedures, refer to paragraph 2-59, page 2-386.

- 1 Remove two cotter pins (1) and pin (2).
- 2 Loosen nut (3) and remove link (4) from clevis (5).
- 3 Remove nut (3) from link (4).

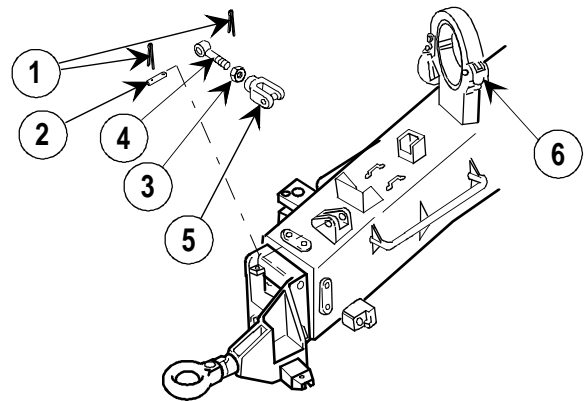

CAUTION

Gun tube travel lock (6) is welded to left trail assembly and should not be removed unless necessary for replacement of authorized parts (TM 9-1025-211-34P). Use care to avoid damage to parts if removal is necessary.

- 4 Remove two cotter pins (7).
- 5 Remove two pins (8).
- 6 Remove ring drawbar coupler (9) from left spade bracket (10).

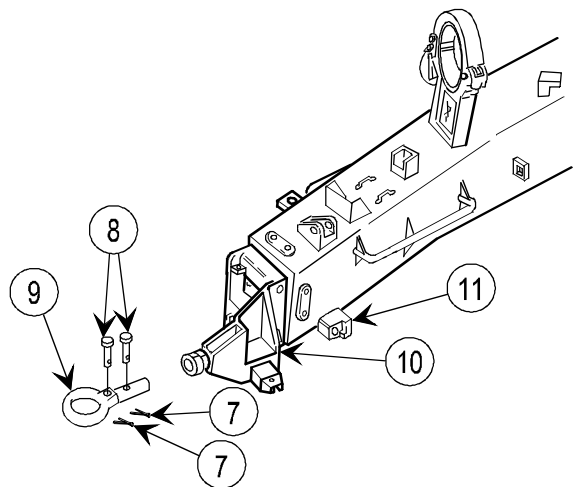

NOTE

If spade bracket (11) is removed from left side, also remove spade bracket (11) on right side. Replacement is in pairs. See TB 9-1025-211-34 for welding instructions.

- 7 Remove spade bracket (11) only if damaged.

2-57. LEFT TRAIL ASSEMBLY—MAINTENANCE INSTRUCTIONS (cont)

DISASSEMBLY

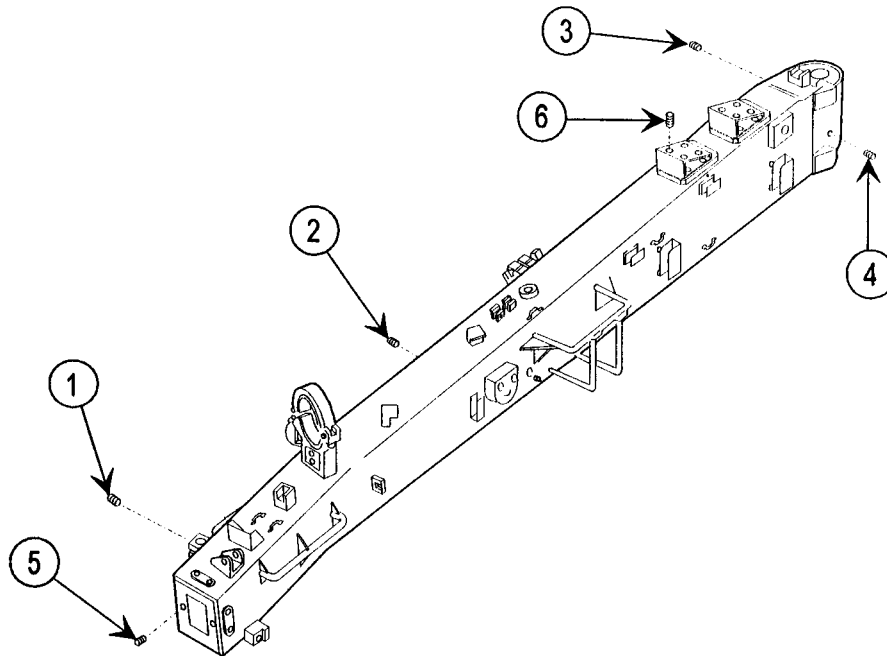

- 1 Remove four threaded inserts (1).
- 2 Remove four threaded inserts (2).
- 3 Remove four threaded inserts (3).
- 4 Remove two threaded inserts (4).
- 5 Remove two threaded inserts (5).
- 6 Remove eight threaded inserts (6).

INSPECTION/REPAIR

NOTE

At time of manufacture, cross section diameter of ring drawbar coupler is $1.59 + 0.06$ in. ($4.04 + 0.15$ cm). Replace ring drawbar coupler if cross section diameter is less than 1.375 in. (3.490 cm).

- 1 Check for broken, damaged, or missing parts.
- 2 Inspect drawbar diameter. Replace if less than 1.375 in. (3.492 cm) diameter.
- 3 Repair is by replacement of authorized parts (TM 9-1025-211-34P).
- 4 Repair spade brackets using spade brackets part kit (12009201). Weld in accordance with TB 9-1025-211-34.

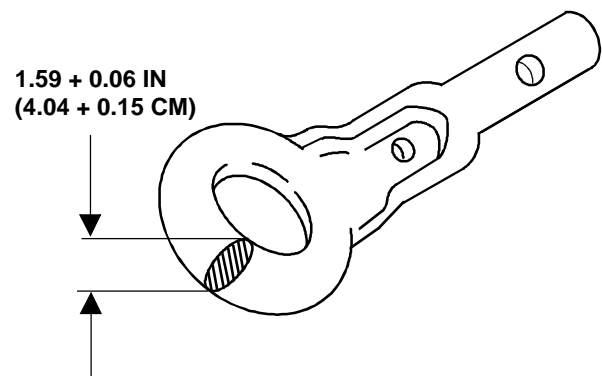

REASSEMBLY

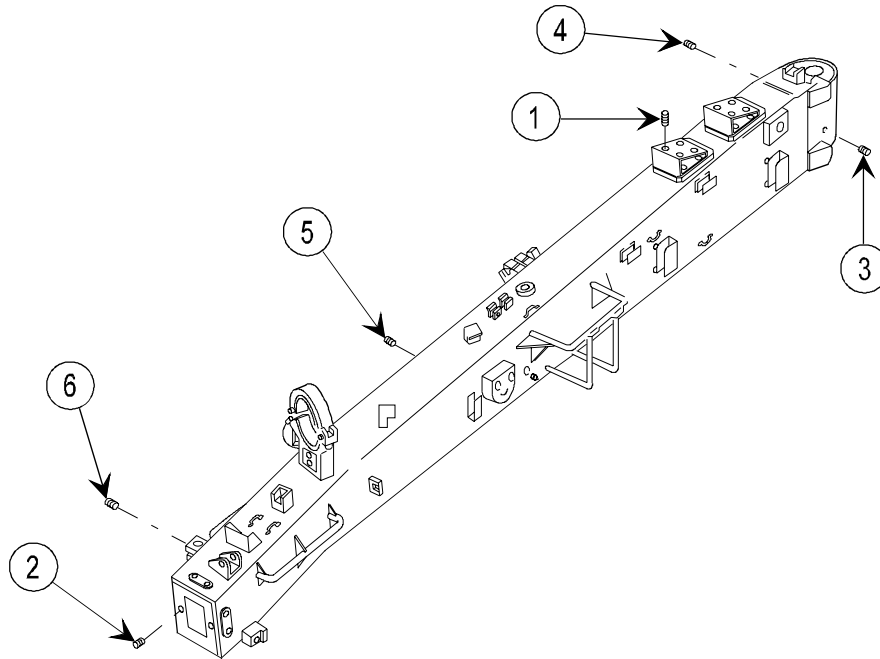

NOTE

Threaded inserts and holes must be coated with wet, unthinned chromate primer when inserts are installed.

- | | |
|--|---|
| <ul style="list-style-type: none"> 1 Install eight threaded inserts (1). 2 Install two threaded inserts (2). | <ul style="list-style-type: none"> 3 Install two threaded inserts (3). 4 Install four threaded inserts (4). 5 Install four threaded inserts (5). 6 Install four threaded inserts (6). |
|--|---|

INSTALLATION

NOTE

Some of the installation procedures for the left trail assembly are the same as for the right trail assembly. Perform the following steps, which apply to the left trail assembly only, before referring to the procedures for the right trail assembly.

- 1 If removed, install spade bracket (1) per welding instructions in TB 9-1025-211-34.
- 2 Install ring drawbar coupler (2) on left spade bracket (3).
- 3 Install two pins (4) and two new cotter pins (5).

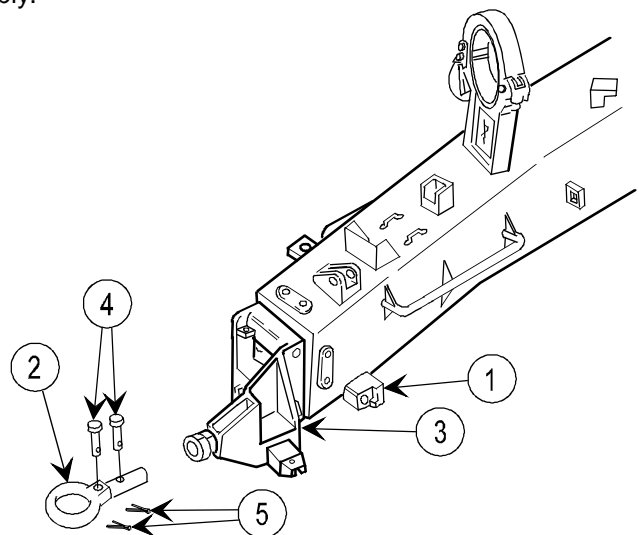

2-57. LEFT TRAIL ASSEMBLY—MAINTENANCE INSTRUCTIONS (cont)

INSTALLATION (cont)

- 4 Install nut (6) on link (7).
- 5 Install link (7) in clevis (8), but do not tighten nut (6).

NOTE

Link (7) must be adjusted with both trails installed and closed to the towing position.

- 6 Position link (7) on bracket (9), and install pin (10).
- 7 Install two new cotter pins (11).
- 8 Install gun tube travel lock (12) (p 2-354), if removed.

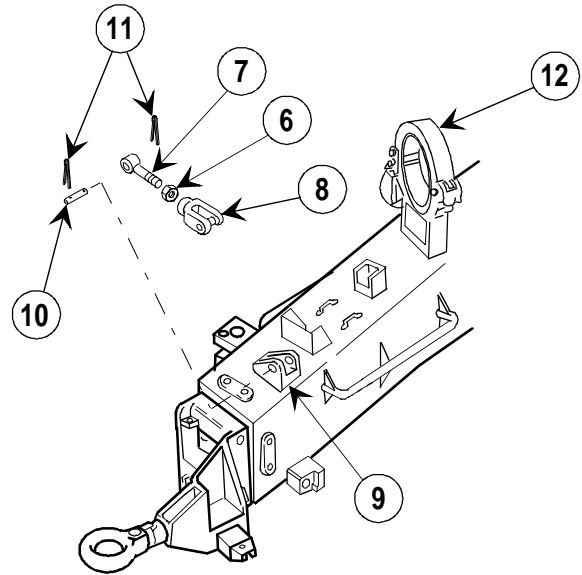

NOTE

For installation of remaining parts attached to left trail assembly, see procedures for right trail assembly (p 2-379) and perform steps 1 thru 11, 17 and 18, and 21 thru 33. For installation of left trail assembly, follow right trail assembly steps 34 thru 52 (p 2-383). Perform steps 56 and 57 (p 2-386) for adjustment of shims (89) on trail stops.

SERVICE

For service of left trail, see procedures on page 2-386.

2-58. RIGHT CLEVIS ASSEMBLY—MAINTENANCE INSTRUCTIONS

THIS TASK COVERS:		
a. Inspection/repair	b. Removal	c. Disassembly
d. Reassembly	e. Installation	
INITIAL SETUP		
Tools and Special Tools Artillery and turret mechanic's ordnance tool kit (SC 5180-95-CL-A12)		
Materials/Parts Cotter pin (MS24665-491) Lock wire (item 35, appx B)		
References TM 9-1025-211-34P		

INSPECTION/REPAIR

- 1 Inspect for broken, damaged, or missing parts.
- 2 Inspect right clevis assembly (1) to see if it is bent and does not align with bracket (2) on bottom carriage (3).
- 3 Repair is by replacement of authorized parts (TM 9-1025-211-34P).

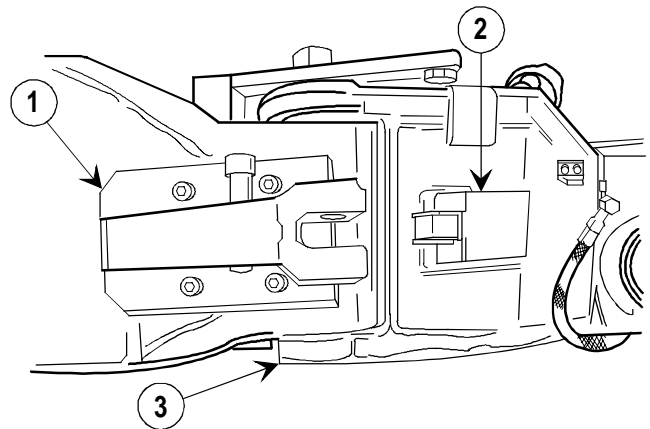

REMOVAL

- 1 Remove cotter pin (1), two links (2), pin cable assembly (3), and tapered plug (4).

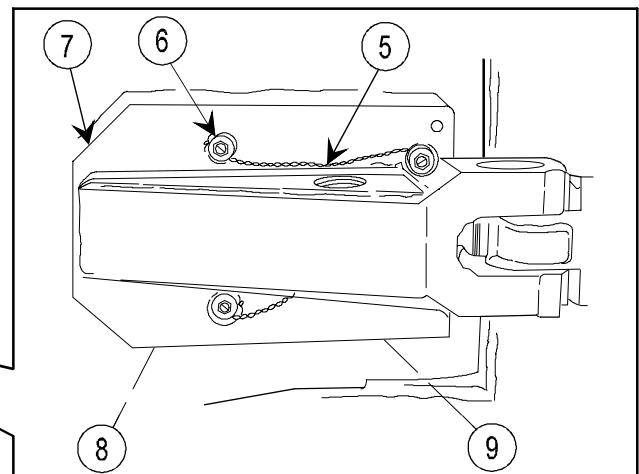
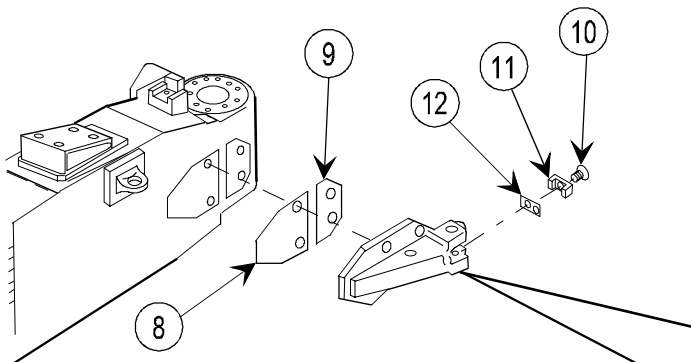
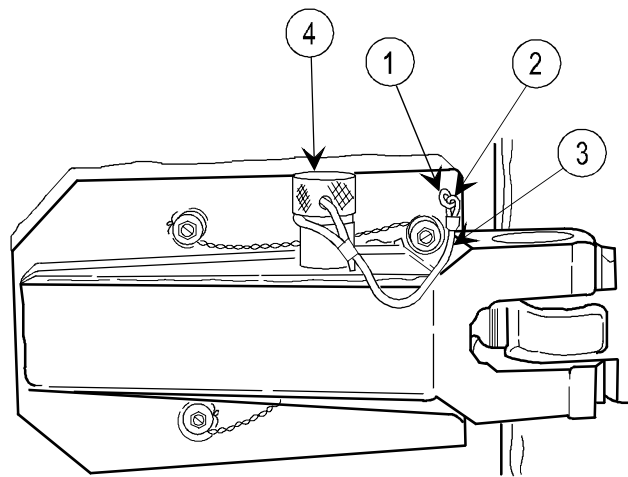

- 2 Remove lock wire (5) and four bolts (6).
- 3 Remove right clevis assembly (7).
- 4 Remove four shims (8).

- 5 Remove four shims (9).
- 6 Remove four screws (10).
- 7 Remove two wear plates (11) and two shims (12).

2-58. RIGHT CLEVIS ASSEMBLY—MAINTENANCE INSTRUCTIONS (cont)

DISASSEMBLY

Remove lock wire and sleeve bushings (1 and 2) from clevis (3).

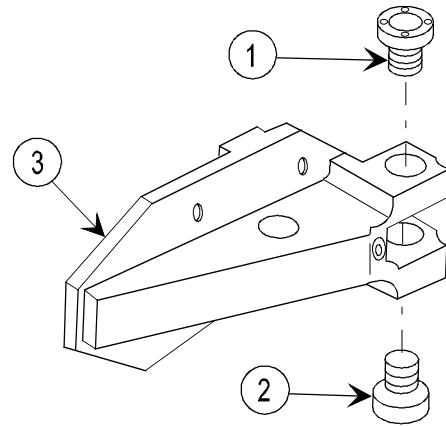

REASSEMBLY

Install sleeve bushings (1 and 2) on clevis (3) and install lock wire.

INSTALLATION

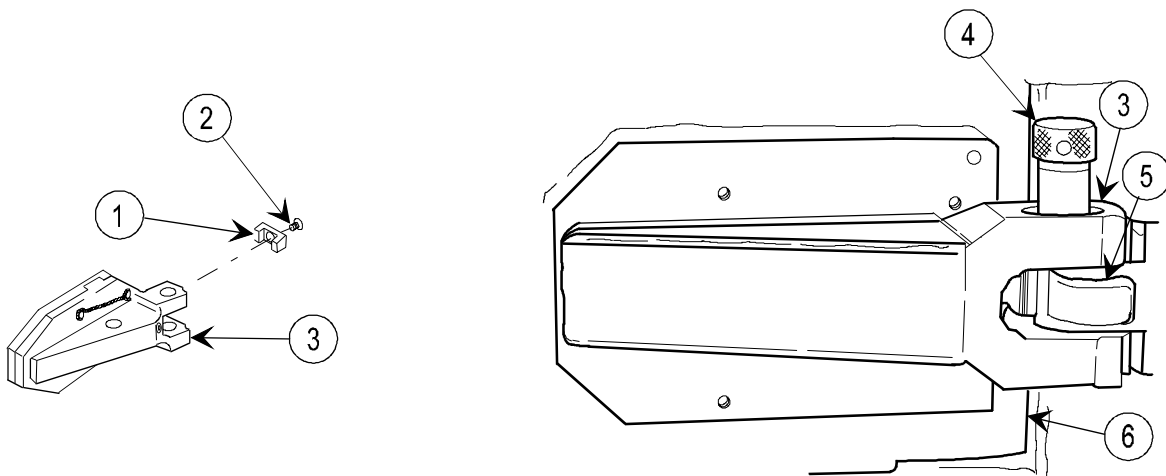

- 1 Install two wear plates (1) and four screws (2) on right clevis assembly (3) without shims.
- 2 Install right clevis assembly (3) and tapered plug (4) on bracket (5).
- 3 Open right trail (6) until key on back of right clevis assembly is aligned with slot on right trail assembly.

NOTE

Shims (7 and 8) must be adjusted to provide continuous contact with right trail assembly (6) and right clevis assembly (3) when installed.

- 4 Install two shims (7 and 8), right clevis assembly (3), four bolts (9), and lock wire (10) on right trail assembly (6).

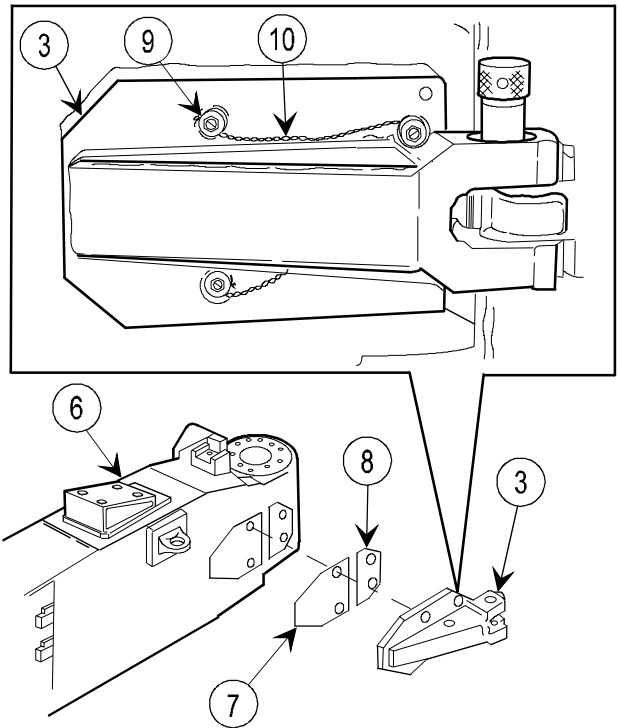

NOTE

Shims (11) must be adjusted to allow 0.000- to 0.002-in. (0.00- to 0.05-mm) clearance between bracket (5) and wear plates (12) with tapered plug (13) installed.

- 5 Adjust thickness of two shims (11) as required.
- 6 Remove tapered plug (13) and move right trail assembly as required to provide access to four screws (14).
- 7 Remove four screws (14) and two wear plates (12).
- 8 Install two shims (11), two wear plates (12), and four screws (14).
- 9 Install tapered plug (13) in stowed position on right clevis assembly (3).
- 10 Install new cotter pin (12).
- 11 Install pin cable assembly (15) and two links (16).

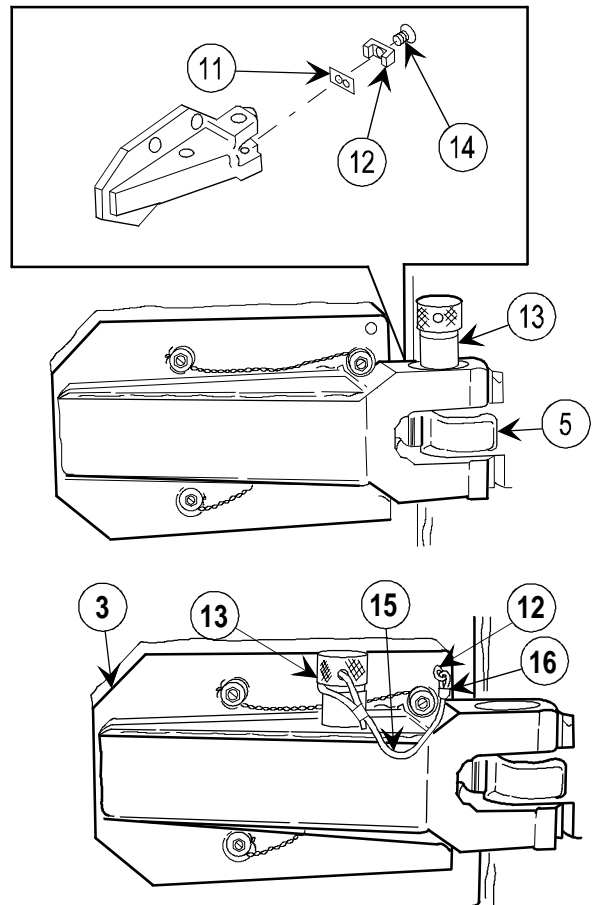

2-59. RIGHT TRAIL ASSEMBLY AND TRAIL LOCKING HANDLE ASSEMBLY—MAINTENANCE INSTRUCTIONS

THIS TASK COVERS:

- | | | |
|---------------|-----------------|----------------------|
| a. Removal | b. Disassembly | c. Inspection/repair |
| d. Reassembly | e. Installation | f. Service |

INITIAL SETUP

Tools and Special Tools

Artillery field maintenance shop equipment SC 4933-95-CL-A12	Jack
Artillery and turret mechanic's ordnance tool kit (SC 5180-95-CL-A12)	M198 repairman field artillery tool kit (5911278)
Blocking	Puller assembly (12008977)
Bushing removal tool (figure C-3)	Sling
	Welder
	3-ton hoist

Materials/Parts

Cleaning compound (item 7, appx B)	Primer (item 20, appx B)
Cotter pin (4) (MS24665-423)	Ring, Retaining (2) (MS16624-4062)
Cotter pin (MS24665-499)	Ring, Retaining (MS16624-1043)
Lock wire (item 34, appx B)	Spade bracket parts kit (122009201)
Lock wire (item 36, appx B)	Tape, antiseizing (item 32, appx B)
Pin (4) (MS51838-180)	WTR grease (item 11, appx B)

Personnel Required: 3

General Safety Instructions

References

TB 9-1025-211-34
TM 9-1025-211-10
TM 9-1025-211-20&P
TM 9-1025-211-34P

WARNING

All lifting devices must be checked in accordance with local Standing Operating Procedure (SOP) to make sure they are in good working condition before starting the lifting operation.

Equipment Conditions

Basic issue items removed from right trail assembly (TM 9-1025-211-10)
Travel lock assembly stowed (TM 9-1025-211-10)
Trails spread far enough to remove firing assembly baseplate (TM 9-1025-211-10)
Firing assembly baseplate removed (TM 9-1025-211-10)
GA bracket and hardware removed (TM 9-1025-211-20&P)
Gun carriage spades removed (TM 9-1025-211-20&P)
Snorkel filter removed (TM 9-1025-211-20&P)

2-328 Brake line air filters removed
2-335 Emergency relay valve removed
2-339 Air pressure tank removed
2-341 Power booster assembly removed
2-347 Front brake parts removed from right trail assembly
2-328 Brake precheck components removed

REMOVAL

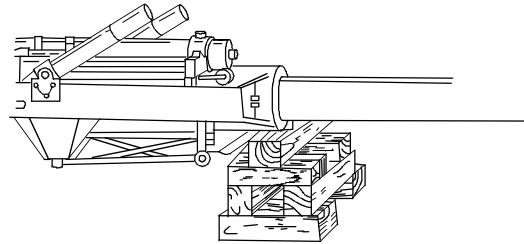
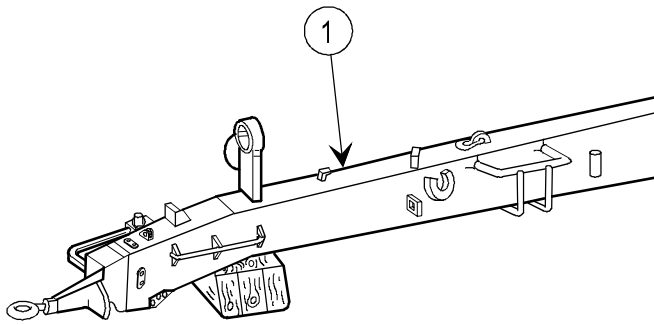

NOTE

The following procedures are written for the right trail assembly; however, some of them also apply for removal of the left trail assembly.

When removing the left trail assembly, item names in parentheses apply where shown.

- 1 Lift up right trail assembly (left trail assembly) (1) approximately 10 in. (25 cm), and place on suitable wood blocking.

WARNING

Cannon must be depressed to rest cradle assembly on suitable wood supports to provide stability and ensure that weapon is properly supported and safe from tipping.

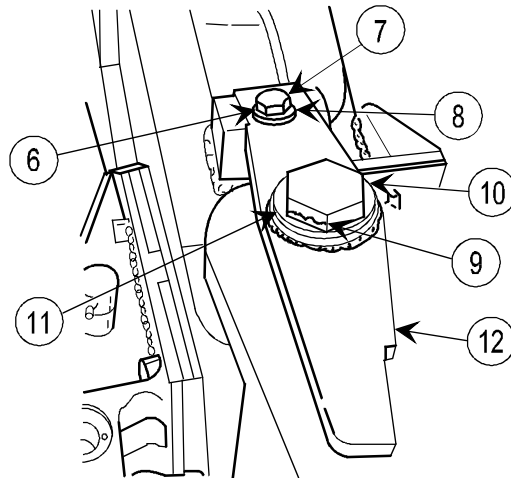
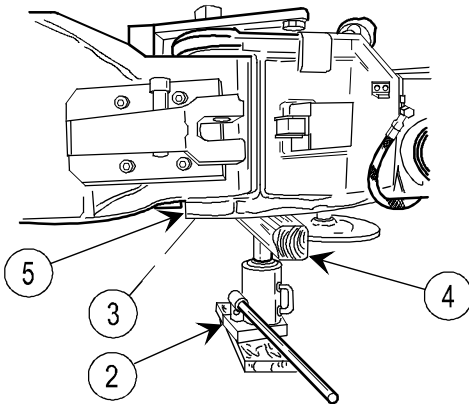

- | | |
|---|---|
| <ol style="list-style-type: none"> 2 Place a jack (2) close to the right trail hinge pin (3). 3 Put a 4- x 4-in. (10- x 10-cm) block (4) on the jack. 4 Jack up bottom carriage assembly (5) until level; then support with wooden blocks. | <ol style="list-style-type: none"> 5 Remove lock wire (6), bolt (7), and washer (8). 6 Remove lock wire (9). 7 Remove bolt (10) and washer (11). 8 Remove traverse stop (12). |
|---|---|

2-59. RIGHT TRAIL ASSEMBLY AND TRAIL LOCKING HANDLE ASSEMBLY—MAINTENANCE INSTRUCTIONS (cont)

REMOVAL (cont)

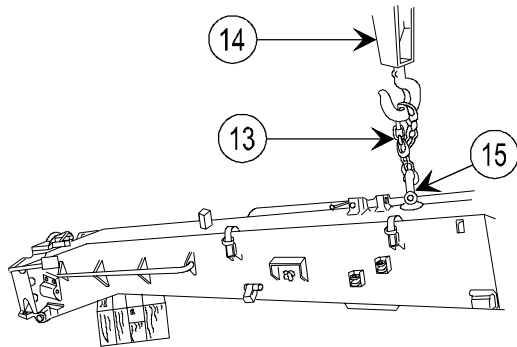

- 9** Attach sling (13) and hoist (14) to clevis assembly (15) and adjust to support the weight of the trail assembly.

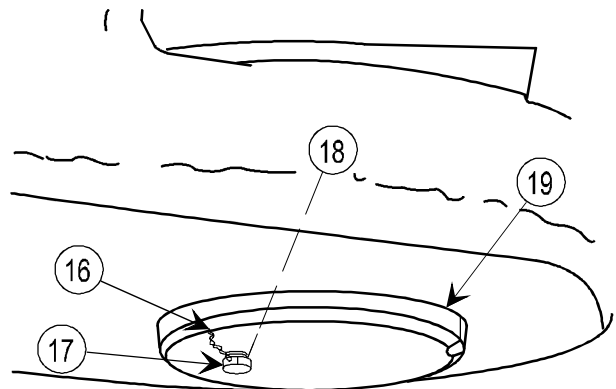

- 10** Remove lock wire (16), bolt (17) and lockwasher (18).
- 11** Remove cap (19).

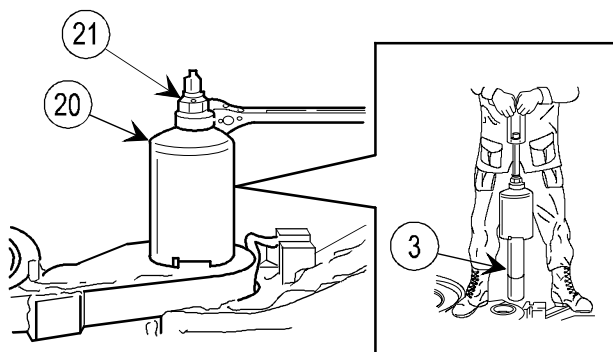

NOTE

If trail hinge pin (3) is difficult to remove, raise or lower trail to relieve tension on trail hinge pin (3).

- 12** Install puller assembly (20) on trail hinge pin (3).
- 13** Remove trail hinge pin (3) by tightening nut (21) until hinge pin is free of sleeve bushings. Lift trail hinge pin (3) out.
- 14** Remove puller assembly (20) from trail hinge pin (3).

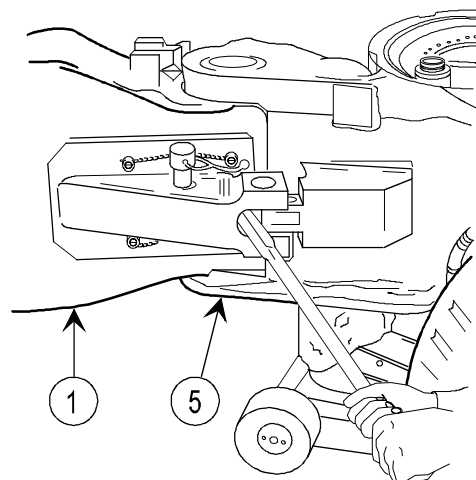

WARNING

Ensure that spades are removed from trails before removal. Personal injury may occur because of the imbalance.

- 15** Slide out right trail assembly (left trail assembly) (1) of bottom carriage assembly (5), and place on suitable blocking.

NOTE

It may be necessary to gently swing trail back and forth when sliding trail out of bottom carriage assembly (5).

- 16 Remove sling (13) and hoist (14).

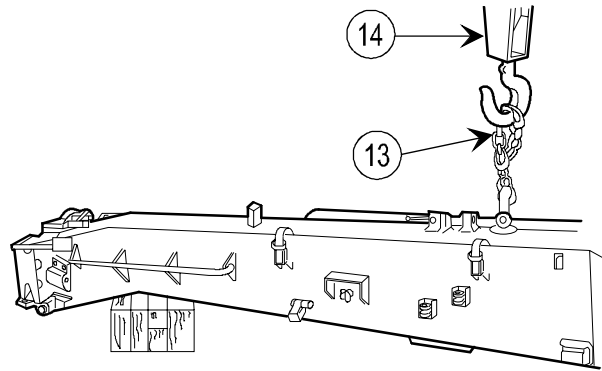

- 17 Remove four screws (22), two pads (23), and two shims (24).
- 18 Remove nut (25), washer (26), and eyebolt (27) only if necessary for replacement of authorized parts (TM 9-1025-211-34P).

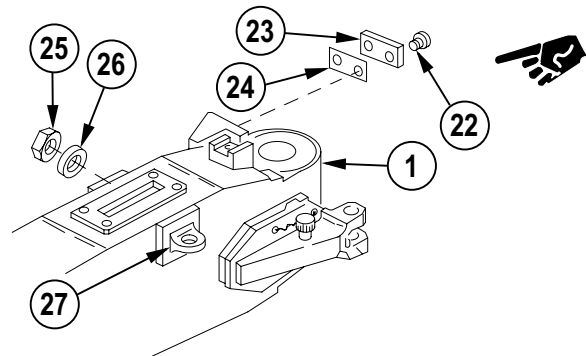

- 19 Remove 28 screws (28) and four bearings (29 and 30) from both ends.

NOTE

The upper and lower trail bushings have different inside diameters. Plates 1 and 2 (fig. 4, appx C) are used to pull the trail bushings. Diameter B should fit inside of bushing to keep puller centered during removal.

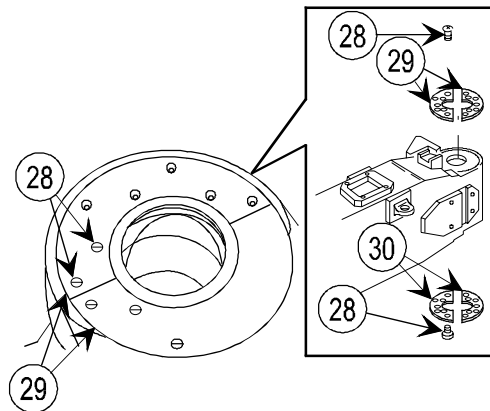

- 20 Select desired plate (31) for bushing to be removed. Position plate (31) inside trail (1) and screw threaded rod (32) into plate (31).

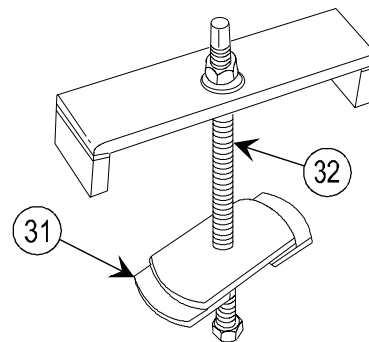

2-59. RIGHT TRAIL ASSEMBLY AND TRAIL LOCKING HANDLE ASSEMBLY—MAINTENANCE INSTRUCTIONS (cont)

REMOVAL (cont)

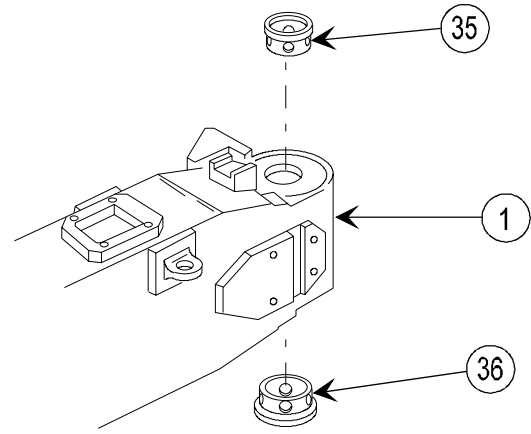
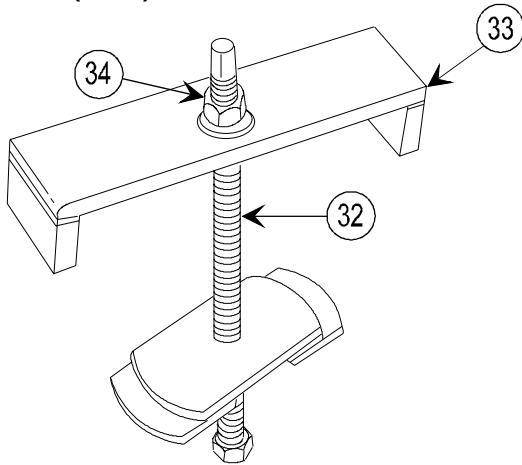

- 21 Position welded plate with arms (33) on threaded rod (32).
- 22 Lower plate (33) onto right trail assembly (left trail assembly) (1).
- 23 Install two nuts (34) on threaded rod (32) and tighten until bushings (35 and 36) are free. Remove two bushings (35 and 36).

NOTE

Nuts (37 and 38) may be tack welded in place. Use chisel to break weld.

- 24 Remove cotter pin (39), nut (37), and washer (40).
- 25 Remove clevis assembly (15) and eyebolt (41) from right trail assembly (left trail assembly) (1).
- 26 Remove nut (38), bolt (42), and clevis (43) from eyebolt (41).
- 27 Remove two pins (44) by filing head off one side.
- 28 Remove two springs (45).
- 29 Remove two levers (46).

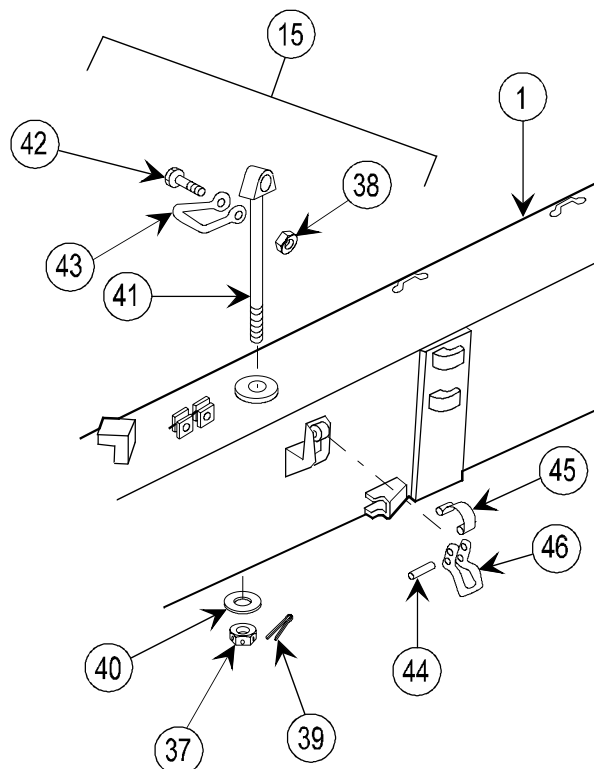

- 30 Remove lock wire (47), four capscrews (48), and four washers.
- 31 Remove holder (50).

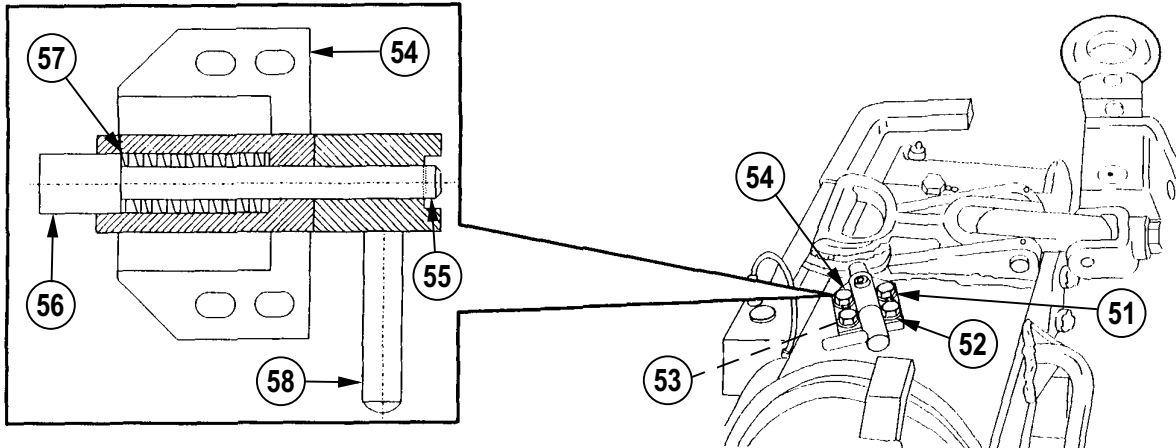
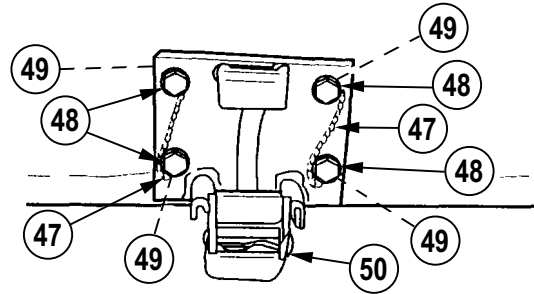

- 32 Remove lock wire (51), four screws (52), and four washers (53) securing trail locking handle assembly (54) to right trail. Remove trail locking handle assembly (54).

NOTE

There are two types of plungers. If the plunger has an external retaining ring, the ring must be removed and replaced with a spring pin.

- 33 Remove external retaining ring or spring pin (55), plunger (56), helix spring (57), and cam handle assembly (58) from trail locking handle assembly (54).

- 34 Remove two pins (59).
- 35 Drive out two pins (60).
- 36 Lift handle (61) from bracket (62).
- 37 Remove pin (63).
- 38 Remove hook (64).

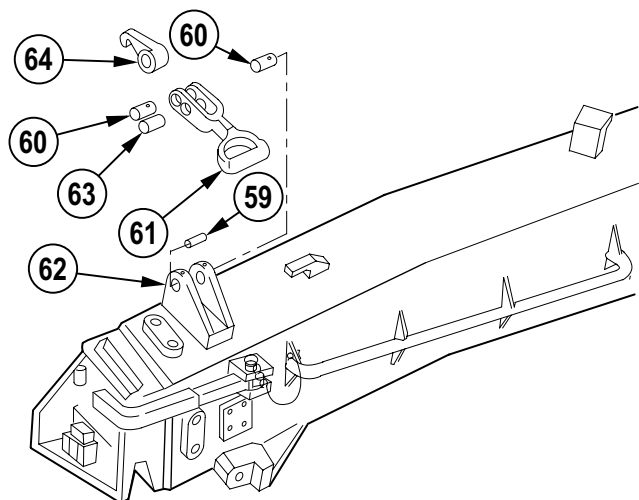

**2-59. RIGHT TRAIL ASSEMBLY AND TRAIL LOCKING HANDLE ASSEMBLY —
 MAINTENANCE INSTRUCTIONS (cont)**

REMOVAL (cont)

- 39 Remove lock wire (65), four capscrews (66), and four washers (67).
- 40 Remove adapter (68) from right trail (left trail).
- 41 Remove four cotter pins (69).
- 42 Remove four nuts (70) and four washers (71).
- 43 Remove two rods (72).
- 44 Remove lock wire (73), two bolts (74), and two washers (75).
- 45 Remove lock wire (76).
- 46 Remove two capscrews (77) and two washers (78).
- 47 Remove right spade bracket (left spade bracket) (79).

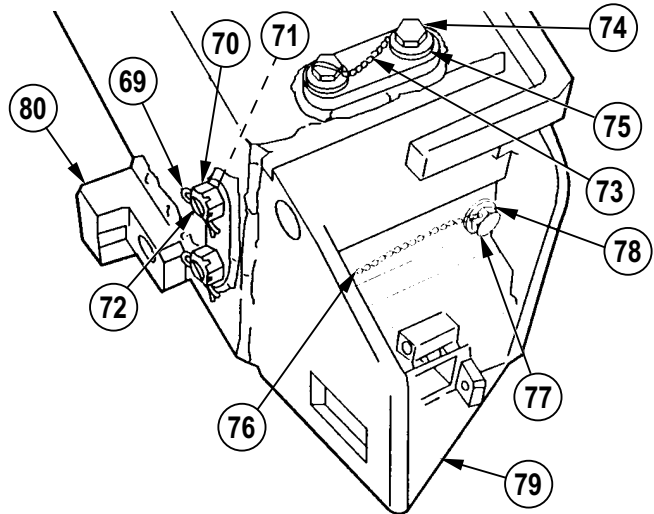
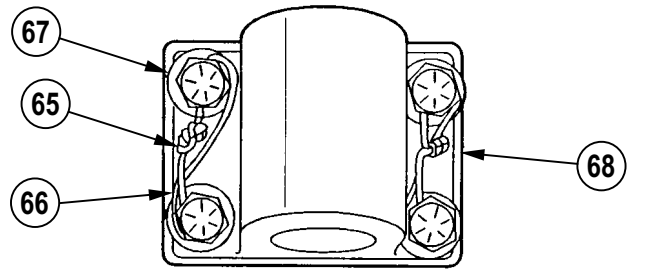

NOTE

If spade bracket (80) is removed from right side, also remove spade bracket from left side. Replacement is in pairs. See TB 9-1025-211-34 for welding instructions.

- 48 Remove spade bracket (80) only if damaged.
- 49 Remove pipe plug (81).
- 50 Deleted.
- 51 Remove retaining ring (86), pin (87), and handle (88).

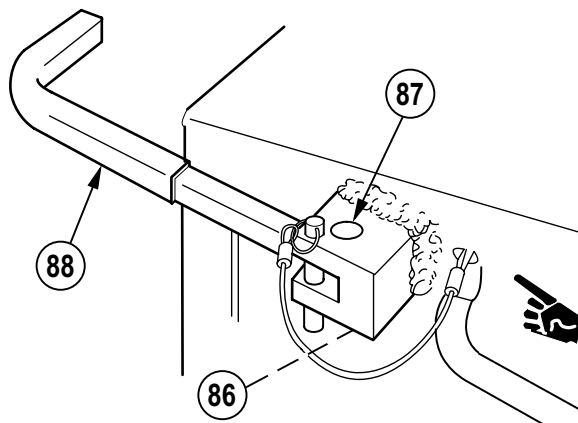
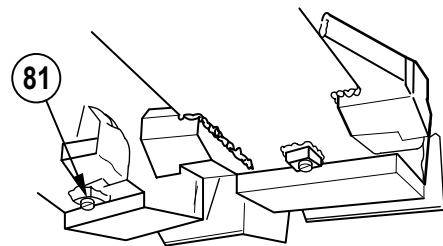

DISASSEMBLY

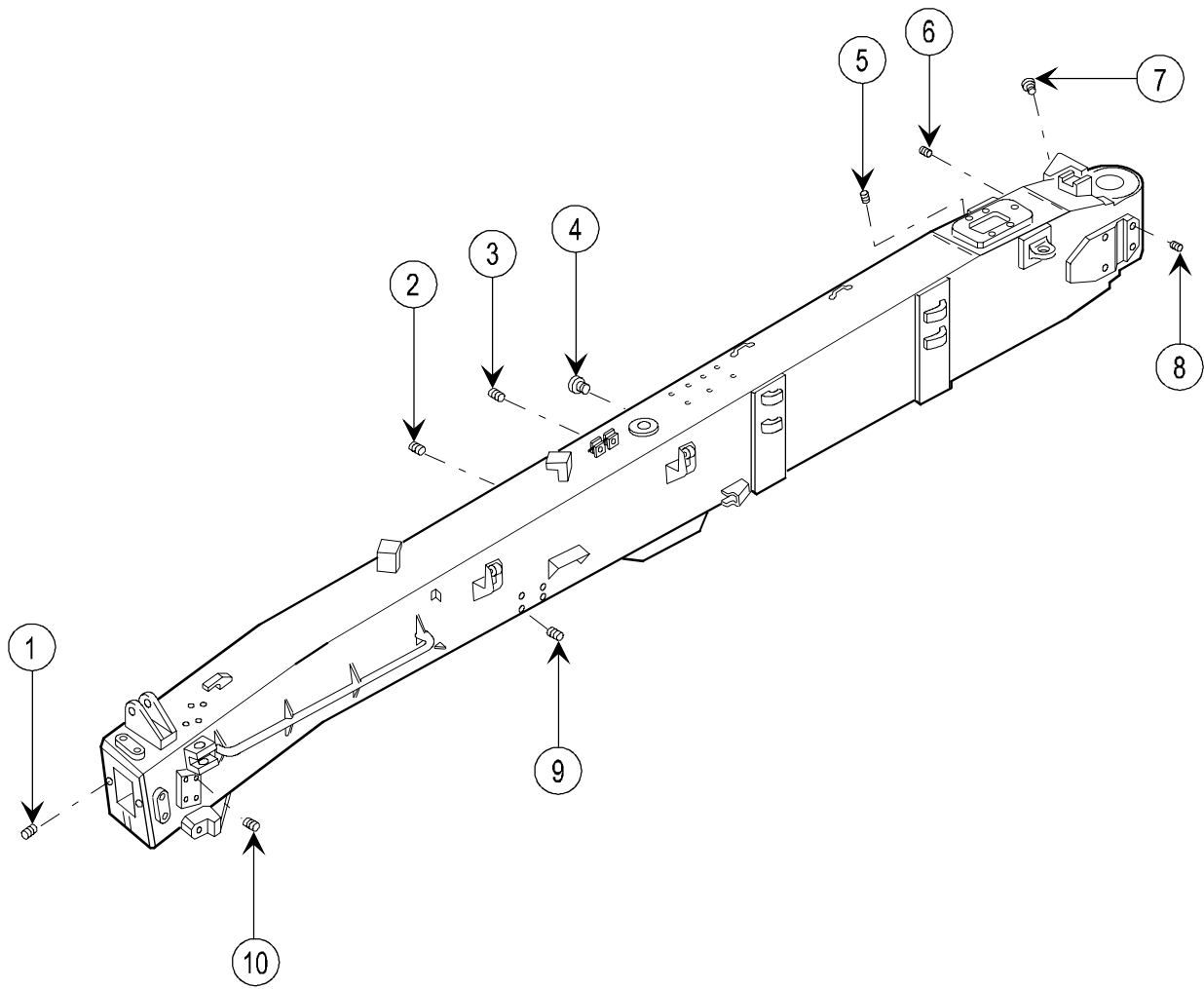

CAUTION

Do not remove threaded inserts unless necessary for replacement of authorized parts (TM 9-1025-211-34P).

- | | | | |
|---|------------------------------------|----|------------------------------------|
| 1 | Remove two threaded inserts (1). | 6 | Remove two threaded inserts (6). |
| 2 | Remove ten threaded inserts (2). | 7 | Remove two threaded inserts (7). |
| 3 | Remove three threaded inserts (3). | 8 | Remove four threaded inserts (8). |
| 4 | Remove eight nuts (4). | 9 | Remove four threaded inserts (9). |
| 5 | Remove four threaded inserts (5). | 10 | Remove four threaded inserts (10). |

2-59. RIGHT TRAIL ASSEMBLY AND TRAIL LOCKING HANDLE ASSEMBLY—MAINTENANCE INSTRUCTIONS (cont)

INSPECTION/REPAIR

- 1 Check for missing, broken, or damaged parts.
- 2 Repair is by replacement of authorized parts (TM 9-1025-211-34P).
- 3 Repair spade brackets only if damaged, using parts kit (12009201). Weld in accordance with TB 9-1025-211-34.
- 4 Repair left and right spade brackets even if only one spade bracket is damaged.

REASSEMBLY

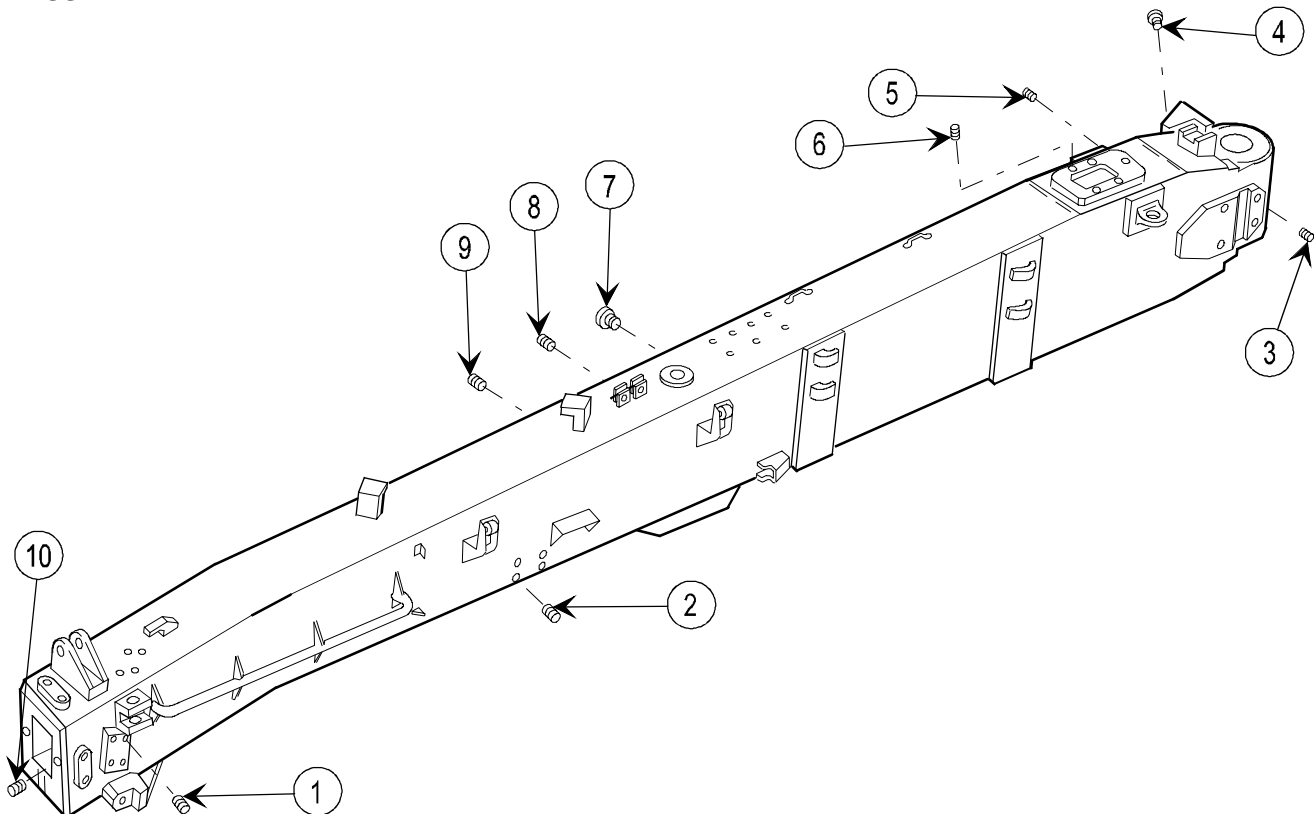

NOTE

All inserts, nuts, and mating holes must be coated with wet, unthinned chromate primer when installed.

- | | | | |
|---|------------------------------------|----|-------------------------------------|
| 1 | Install four threaded inserts (1). | 6 | Install four threaded inserts (6). |
| 2 | Install four threaded inserts (2). | 7 | Install eight nuts (7). |
| 3 | Install four threaded inserts (3). | 8 | Install three threaded inserts (8). |
| 4 | Install two threaded inserts (4). | 9 | Install ten threaded inserts (9). |
| 5 | Install two threaded inserts (5). | 10 | Install two threaded inserts (10). |

INSTALLATION

- 1 Position handle (1) on right trail (left trail) and secure with pin (2) and new external retaining ring (3).
- 2 Deleted.

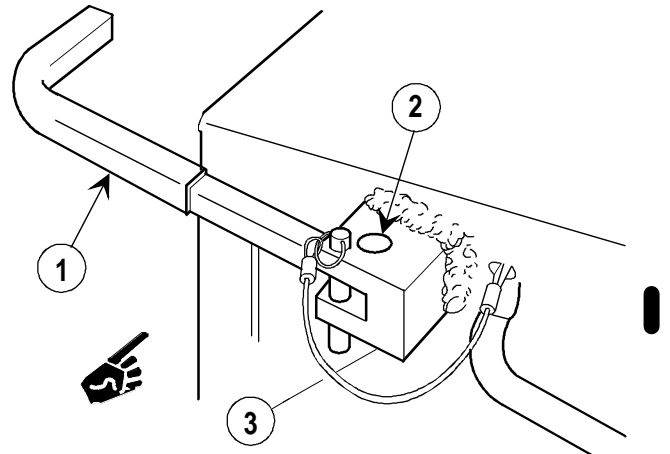

NOTE

The following procedures are written for the right trail assembly; however, some of them also apply for installation of the left trail assembly.

When installing the left trail assembly, item names in parenthesis apply where shown.

- 3 Wrap threads of pipe plug (9) with antiseizing tape and install.

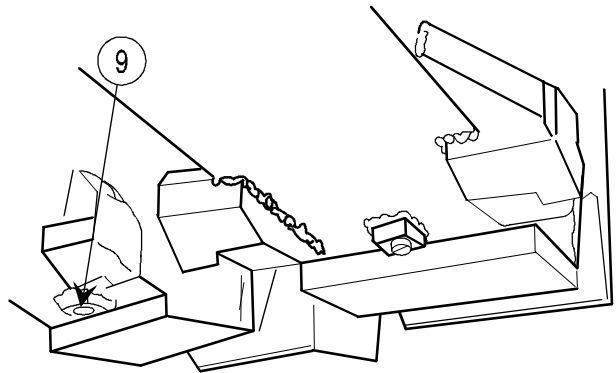

NOTE

Refer to TB 9-1025-211-34 for replacement of welded spade bracket (10).

- 4 If removed, install spade bracket (10).
- 5 If removed, install right spade bracket (left spade bracket) (11) and install two rods (12).
- 6 Install four washers (13) and four nuts (14).
- 7 Install four new cotter pins (15).

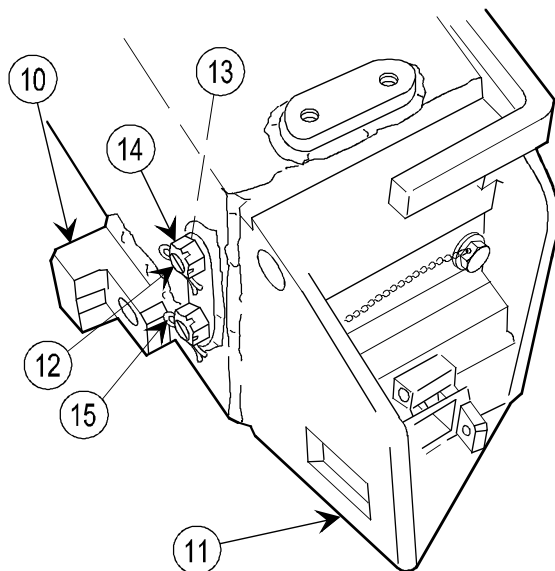

2-59. RIGHT TRAIL ASSEMBLY AND TRAIL LOCKING HANDLE ASSEMBLY — MAINTENANCE INSTRUCTIONS (CONT)

INSTALLATION (cont)

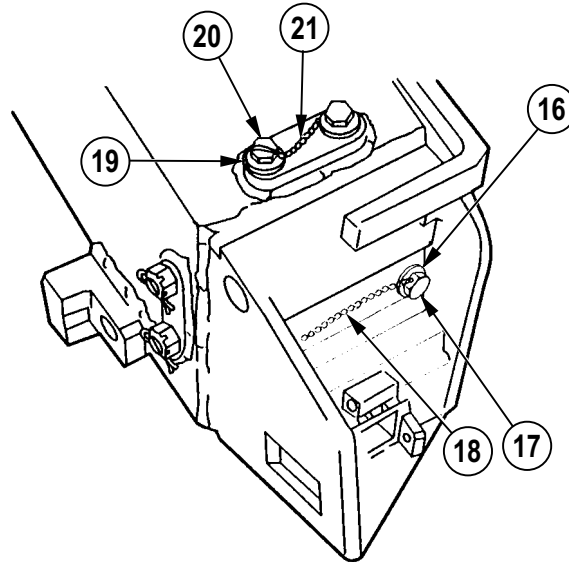

- 8 Install two washers (16), two capscrews (17), and lock wire (18) (item 36, appx B).
- 9 Install two washers (19), two bolts (20), and lock wire (21) (item 36, appx B).

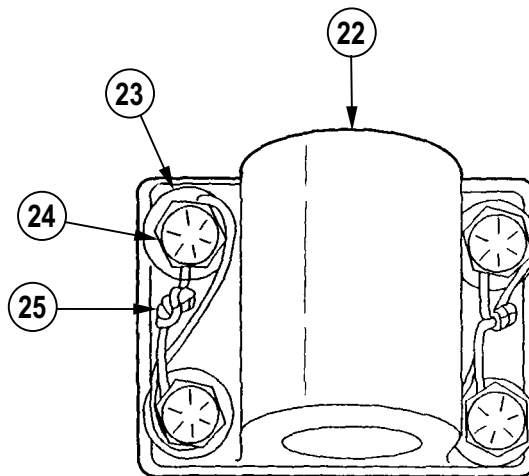

- 10 Install adapter (22) on right trail (left trail).
- 11 Install four washers (23), four capscrews (24), and lock wire (25) (item 36, appx B).

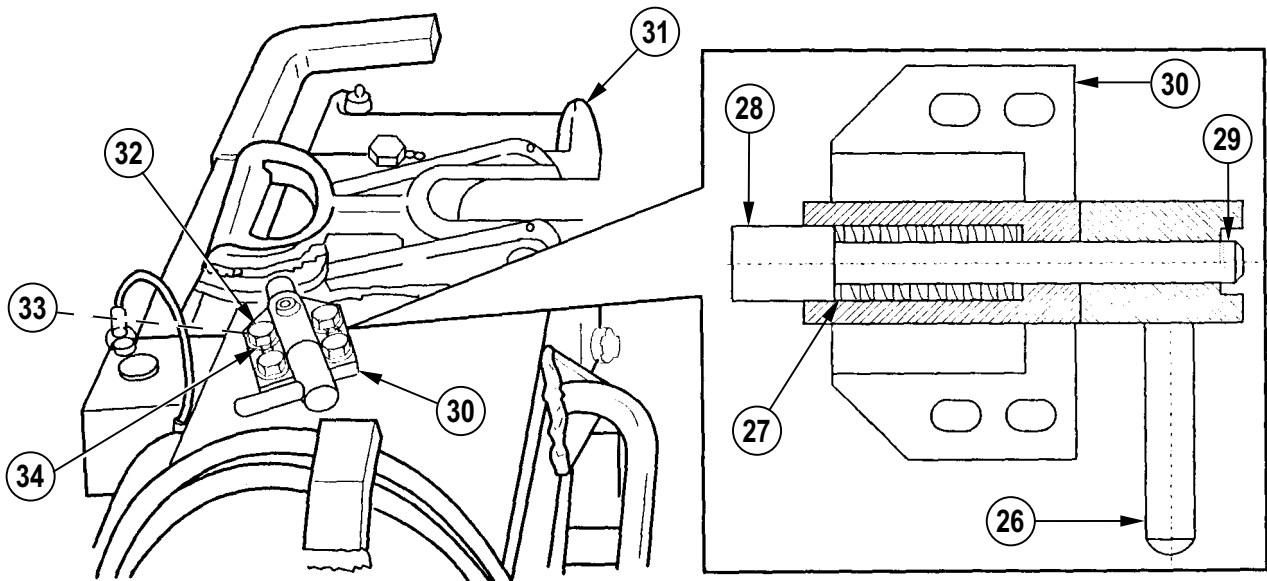
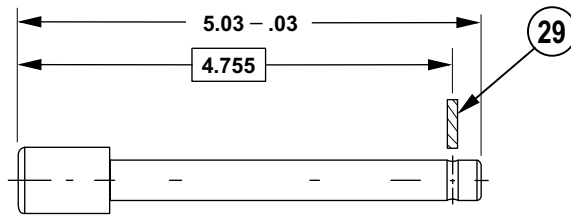

NOTE

There are two types of plungers. One configuration has a groove and the other does not. If the plunger being replaced has a groove, drill a 3/32 in. (0.26 cm) hole as shown.

- 12 Install cam handle assembly (26), helix spring (27), and plunger (28). Install new spring pin (29) in plunger. Install in trail locking handle assembly (30).
- 13 Position trail locking handle assembly (30) on right trail assembly (31) and secure with four screws (32), four washers (33), and lock wire (34) (item 36, appx B).

- 14 Aline hook hole (35) with holes on handle (36), and install pin (37).
- 15 Reassemble handle (36) to bracket (38), and install two pins (39).
- 16 Install two pins (40) into bracket (38) and two pins (39).

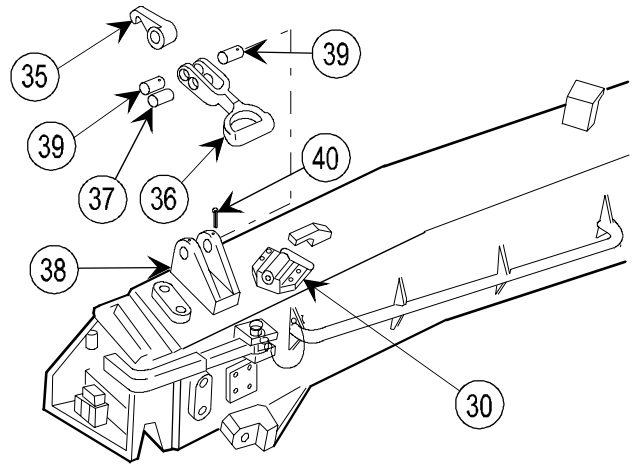

- 17 Install holder (41) on right trail (31) (left trail).
- 18 Install four washers (42), four capscrews (43) and install lock wire (44) (item 36, appx B).

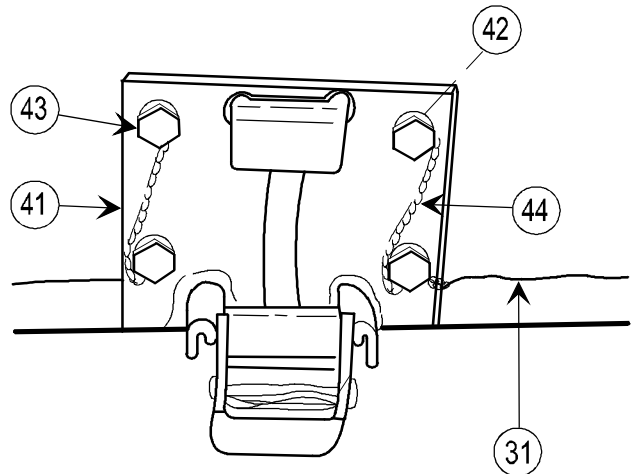

- 19 Position two levers (45) and two springs (46), and install two pins (47).
- 20 Peen ends of two pins (47).

WARNING

Local safety welding procedures must be followed when performing welding operation.

- 21 Install clevis (48), bolt (49), and nut (50) on eyebolt (51). Tack weld nut (50) on eyebolt (51) at two locations 180 degrees apart.
- 22 Install clevis assembly (52) and eyebolt (51) on right trail assembly (left trail assembly) (31).
- 23 Install washer (53).
- 24 Install nut (54) and tighten to allow free rotation of clevis assembly (52).
- 25 Install new cotter pin (55). Tack weld nuts (54) on eyebolt (51) at two locations 180 degrees apart.

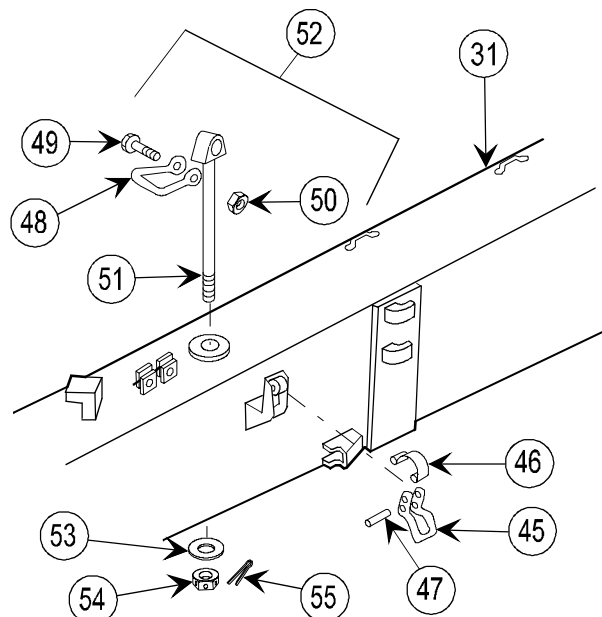

2-59. RIGHT TRAIL ASSEMBLY AND TRAIL LOCKING HANDLE ASSEMBLY—MAINTENANCE INSTRUCTIONS (cont)

INSTALLATION (cont)

- 26 Apply light coat of WTR grease on bushings (56 and 57).
- 27 Position bushing (56 and 57) on right trail assembly (left trail assembly) (31) and install. Use bushing puller if required.

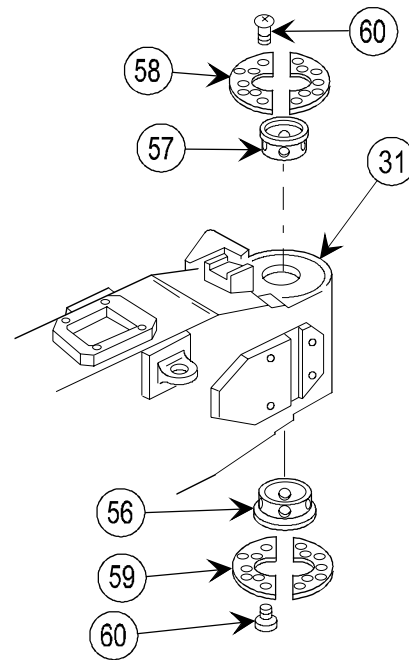

NOTE

Ensure that thicker bearings are installed at the top.

- 28 Install two bearings (58) and two bearings (59) on right trail assembly (left trail assembly) (31).
- 29 Install 28 screws (60).

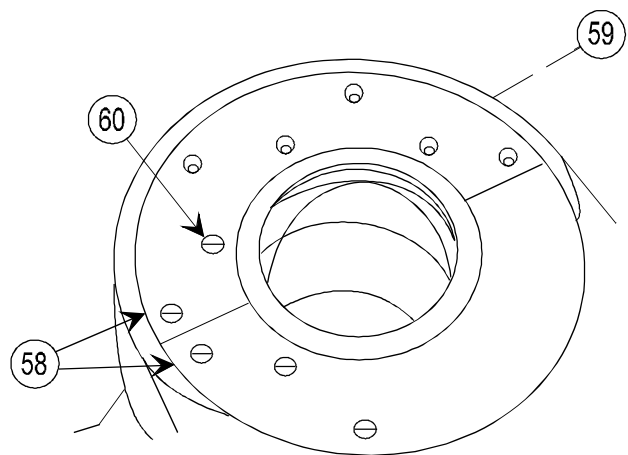

- 30 Install two pads (61) on right trail assembly (left trail assembly) (31).
- 31 Install four screws (62) on right trail assembly (left trail assembly).

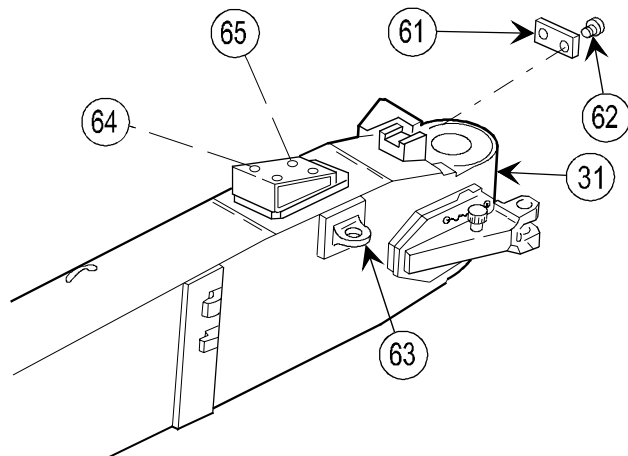

WARNING

Local safety welding procedures must be followed when performing welding operation.

- 32 Install eyebolt (63), washer (64), and nut (65). Tack weld nut to eyebolt (63) in two places on right trail assembly (left trail assembly).

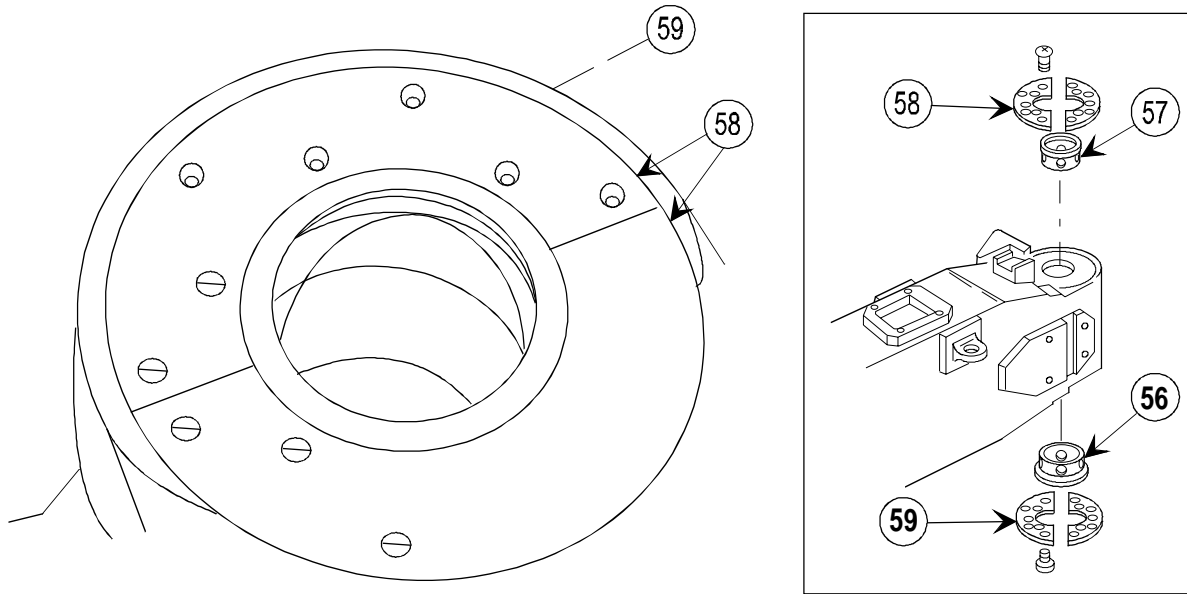

NOTE

Ensure bottom carriage trail surface is level prior to trail installation. Lift trail to height of opening in bottom carriage. Level trail and install.

- 33 Coat two bushings (56 and 57) and four bearings (58 and 59) with WTR grease.

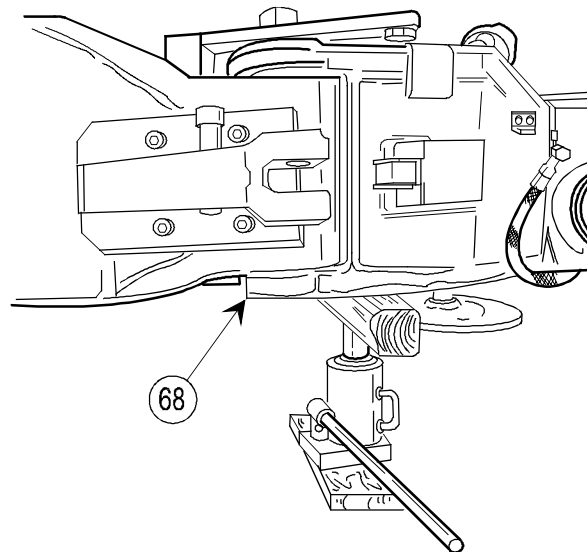
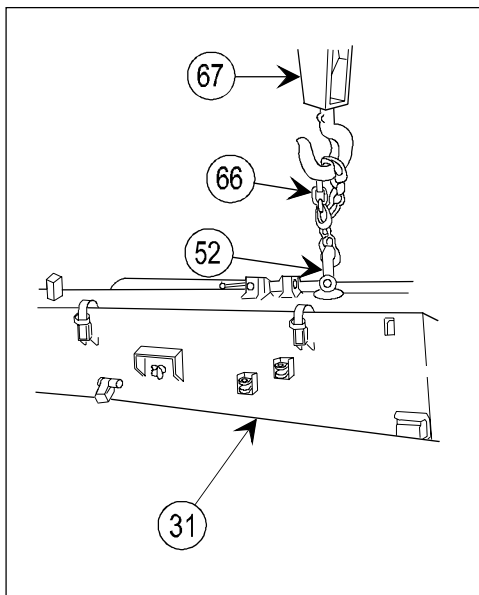

- 34 Attach sling (66) and hoist (67) to clevis assembly (52).
- 35 Lift right trail assembly (left trail assembly) (31) with hoist (67) and slide into position on bottom carriage assembly (68).

2-59. RIGHT TRAIL ASSEMBLY AND TRAIL LOCKING HANDLE ASSEMBLY—MAINTENANCE INSTRUCTIONS (cont)

INSTALLATION (cont)

CAUTION

Use puller assembly (69) to seat hinge pin (70). Do not attempt to drive hinge pin with hammers or similar tools. Raise and lower right trail assembly slightly with hoist if necessary to eliminate binding. Flats on hinge pin must be aligned with lugs (71).

- 36 Attach puller assembly (69) to top of hinge pin (70).
- 37 Coat hinge pin (70) with WTR grease.

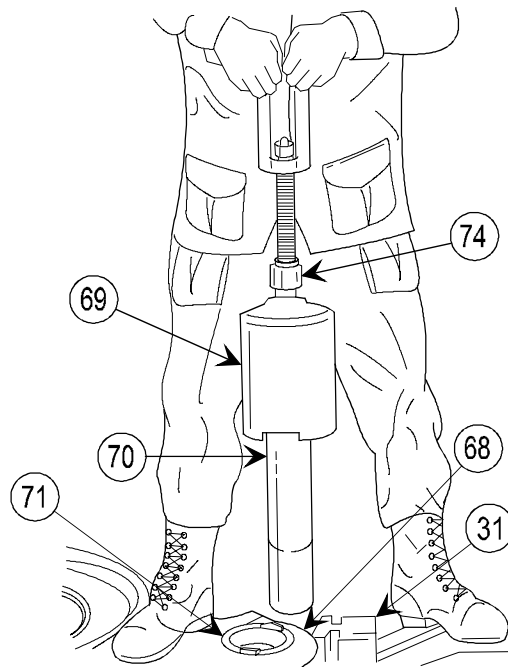

NOTE

When replacement of the hinge pin (70) or cap (72) is required, both of these parts must be replaced to ensure that the hole for bolt (73) is drilled and tapped properly. If installing a new hinge pin proceed with step 38. If installing the same pin removed, proceed to step 45.

- 38 Install hinge pin (70) in trail (31) and bottom carriage (68).
- 39 Screw cap into hinge pin (70) and draw tight with spanner wrench.

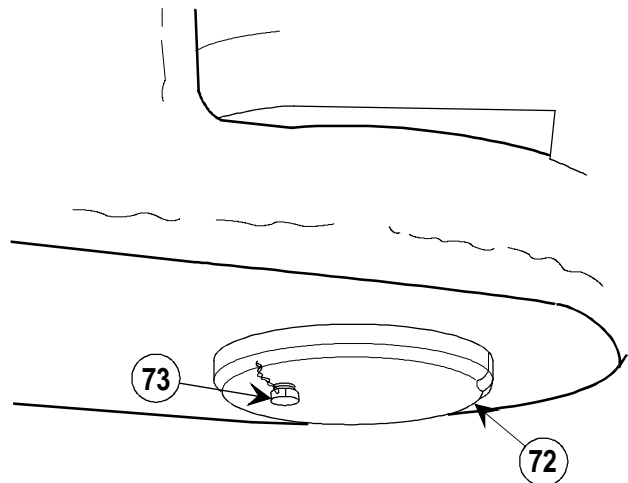

- 40 Apply a witness mark to cap (72) and the bottom carriage to reference cap (72) location during assembly.
- 41 Use hole in cap (72) to center punch hole location in hinge pin (70).
- 42 Remove cap (72) and hinge pin (70) from bottom carriage.

- 43 Assemble cap (72) to hinge pin (70). Shim as required to aline the hole in cap (72) with center punch mark.

NOTE

Ensure that cap (72) is drawn tight on hinge pin (70) prior to drilling and tapping the 1/4-20 hole in the cap and hinge pin. Take hinge pin to machine shop for drilling and tapping operation.

- 44 Drill and tap the hole (250-20 UNC-2B, 0.62 in. deep) in the cap (72) and hinge pin (70). Remove cap (72) and clean chips from cap (72) and hinge pin (70).
- 45 Lift and position hinge pin (70) in hole through bottom carriage assembly (68) and right trail assembly (left trail assembly) (31).
- 46 Detach puller assembly (69) from hinge pin (70).
- 47 Remove puller assembly (69).

NOTE

Sling and hoist may now be detached.

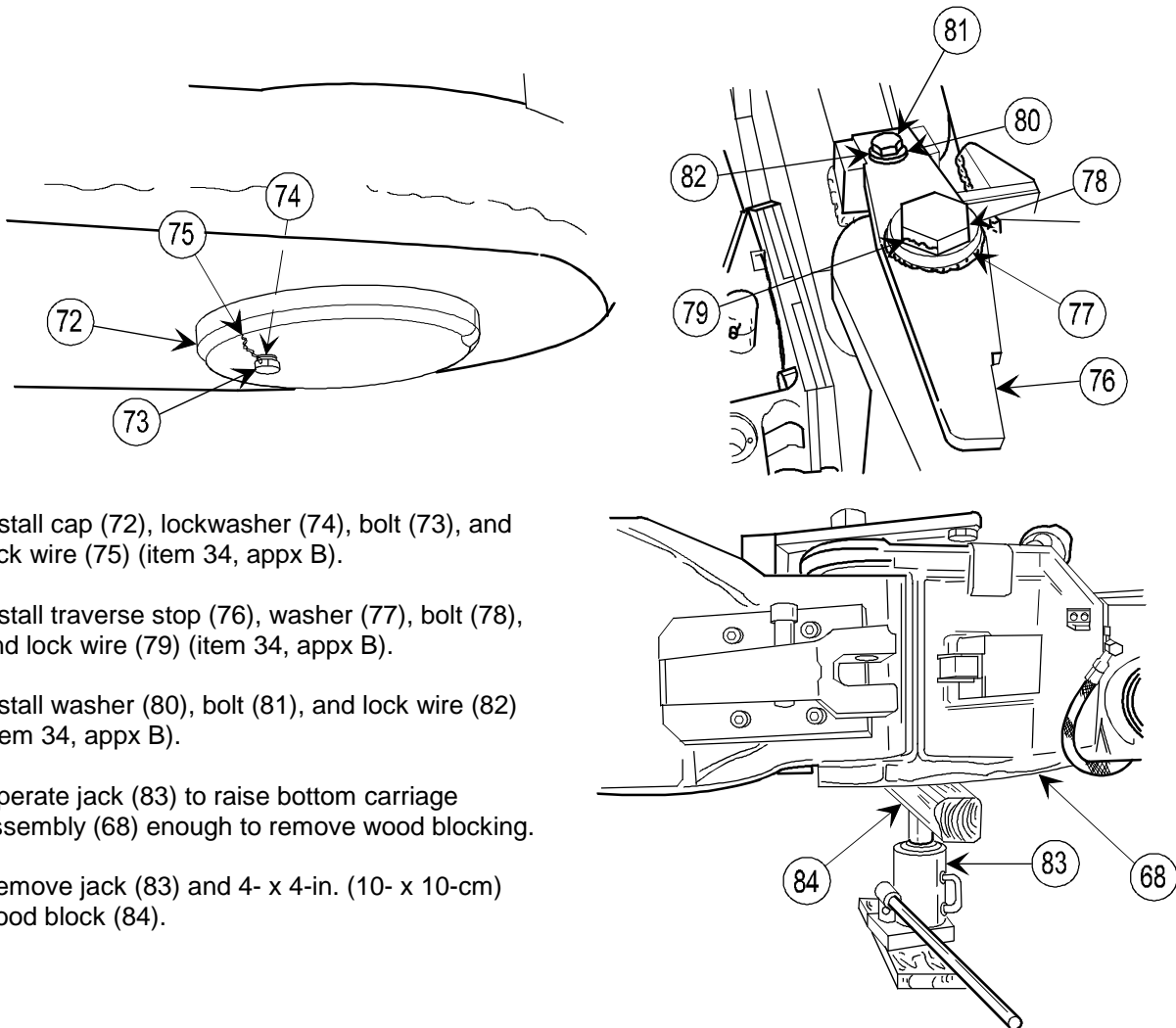

- 48 Install cap (72), lockwasher (74), bolt (73), and lock wire (75) (item 34, appx B).
- 49 Install traverse stop (76), washer (77), bolt (78), and lock wire (79) (item 34, appx B).
- 50 Install washer (80), bolt (81), and lock wire (82) (item 34, appx B).
- 51 Operate jack (83) to raise bottom carriage assembly (68) enough to remove wood blocking.
- 52 Remove jack (83) and 4- x 4-in. (10- x 10-cm) wood block (84).

2-59. RIGHT TRAIL ASSEMBLY AND TRAIL LOCKING HANDLE ASSEMBLY—MAINTENANCE INSTRUCTIONS (cont)

INSTALLATION (cont)

- 53 Remove (left trail assembly) right trail assembly (85) from blocking.
- 54 Close and lock trail assemblies (85 and 31) by engaging hook (35) in link (86) and moving handle (36) to the locked position.

NOTE

If trail assemblies do not lock tightly or cannot be locked, loosen nut (87).

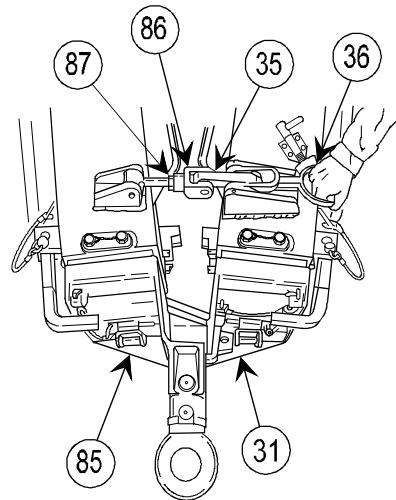

- 55 Unlock right trail assembly (31) and left trail assembly (85) and spread to provide access to four screws (88).

NOTE

Shims (89) must be adjusted and installed so there is no clearance between pads (90) and bottom carriage assembly.

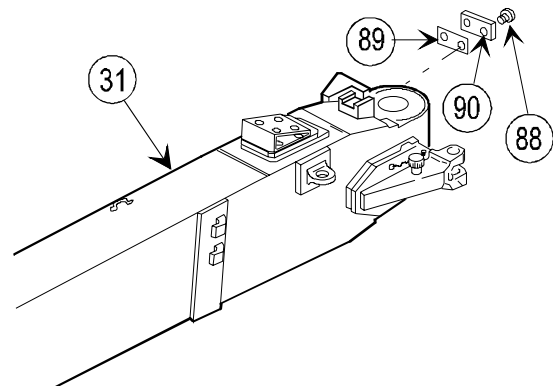

- 56 Remove four screws (88) and two pads (90).
- 57 Install shims (89), two pads (90), and four screws (88).

SERVICE

NOTE

The requirement to replace an out of tolerance trail bushing is not criterion for deadlining the howitzer. If new trail bushing is not on hand, rotate the worn area of the old bushing 90 degrees to the axis of the trail, install and use it until the replacement bushing is available.

- 1 Trails should be removed annually. Hinge pin, upper bushing, and lower bushing should be checked for the following:

WARNING

Cleaning solvent is toxic and flammable. Use in well-ventilated area. Avoid breathing the vapors and keep away from ignition sources.

- a. Clean trail bushings with cleaning compound. Check to ensure there are no burrs, nicks, cracks or distortion. Upper bushing should not be worn beyond 4.004 in. (10.170 cm) and the lower bushing should not be worn beyond 3.504 in. (8.900 cm). If either bushing is worn beyond these limits, they should be replaced.

NOTE

It may be necessary to plug the remaining holes in the bushing to ensure grease flows through all four holes.

b. Apply WTR grease to check grease flow through the grease access holes to the grease grooves. If grease does not flow, use bushing removal tool to remove bushings, and clean bushings.

NOTE

Hinge pin chrome plating should be intact with no severe pitting or rust accumulation.

c. Hinge pin should be replaced if the 4.0-in. (10.0-cm) or 3.5-in. (8.9-cm) diameters show signs of pitting/gouging or rough irregular surfaces.

2 Trails that are extremely hard to open or close should have this service performed at the earliest opportunity. Howitzers that have been in deep water fordings should also have this service performed at the earliest opportunity.

SECTION VI. AUXILIARY EQUIPMENT MAINTENANCE INSTRUCTIONS

Section Index

Paragraph	Page
2-60. Nitrogen Hose Assembly—Maintenance Instructions	2-387
2-61. Ammunition Loading Tray—Maintenance Instructions	2-391
2-62. Nitrogen Charging Assembly—Maintenance Instructions	2-392
2-63. Air Pressure Gage Assembly—Maintenance Instructions.....	2-393
2-64. Hinge Pin Puller Assembly—Maintenance Instructions.....	2-394
2-65. Safety Strut Assembly—Maintenance Instructions.....	2-395
2-65.1. M45 Recoil Mechanism Exerciser—Maintenance Instructions	3-396

2-60. NITROGEN HOSE ASSEMBLY—MAINTENANCE INSTRUCTIONS

THIS TASK COVERS:			
a. Disassembly	b. Inspection/repair	c. Reassembly	d. Testing
INITIAL SETUP			
Tools and Special Tools			
Artillery and turret mechanic's ordnance tool kit (SC 5180-95-CL-A12)			
M198 repairman field artillery tool kit (5911278)			
Nitrogen charging kit (8449334)			
Materials/Parts			
Soap (item 30, appx B)			
References			
TM 9-1025-211-10			
TM 9-1025-211-34P			

2-60. NITROGEN HOSE ASSEMBLY—MAINTENANCE INSTRUCTIONS (cont)

DISASSEMBLY

- 1 Remove cap (1) from valve (2).
- 2 Remove valve (2) from tee (3).
- 3 Remove two swivel connectors (4) from two hose assemblies (5).
- 4 Remove two hose assemblies (5) from tee (3).

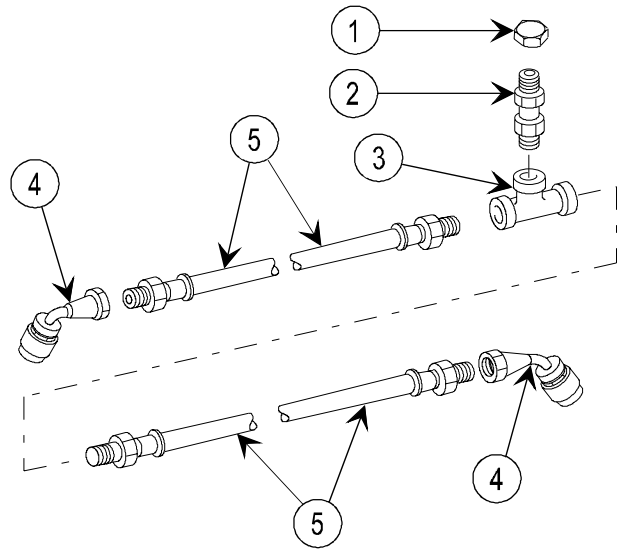

INSPECTION/REPAIR

- 1 Check for broken, damaged, or missing parts.
- 2 Repair is by replacement of authorized parts (TM 9-1025-211-34P).

REASSEMBLY

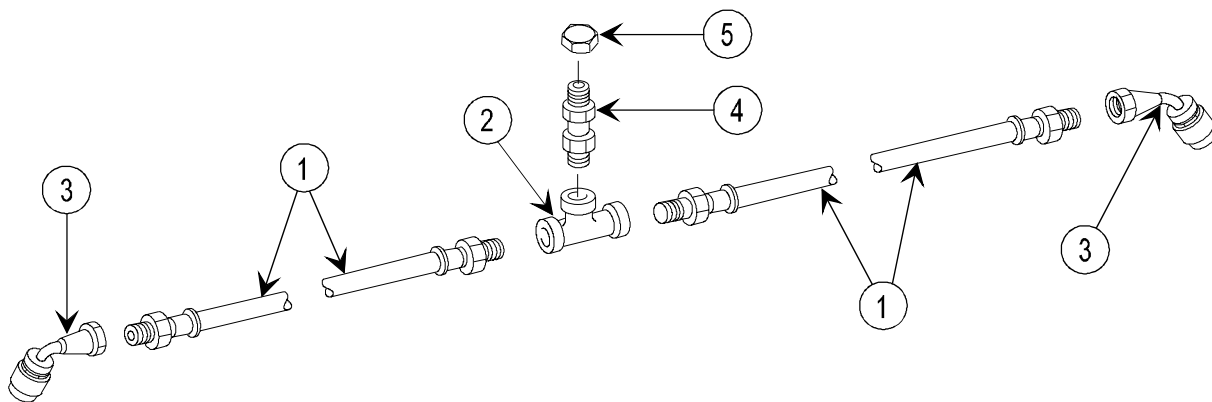

- | | |
|--|--|
| <ol style="list-style-type: none"> 1 Install two hose assemblies (1) on tee (2). 2 Install two swivel connectors (3) on hose assemblies (1). | <ol style="list-style-type: none"> 3 Install valve (4) on tee (2). 4 Install cap (5) on valve (4). |
|--|--|

TESTING

WARNING

Nitrogen under pressure is dangerous. Eye protection must be worn throughout this procedure.

NOTE

Procedures are written for one equilibrator cylinder, but apply to both unless otherwise noted.

- 1 Remove protective dust cap (1) and valve cap (2) from equilibrator cylinder (3).
- 2 Attach nitrogen hose assembly (4) to check valves (5) on equilibrator cylinders (3).

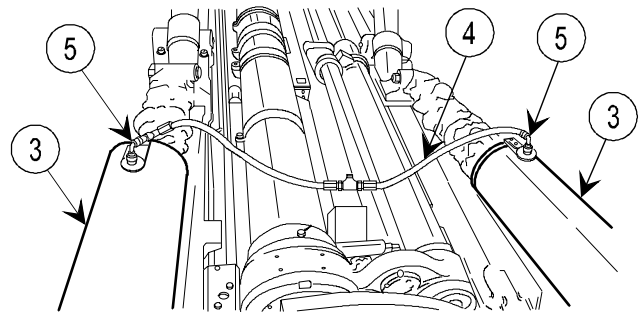
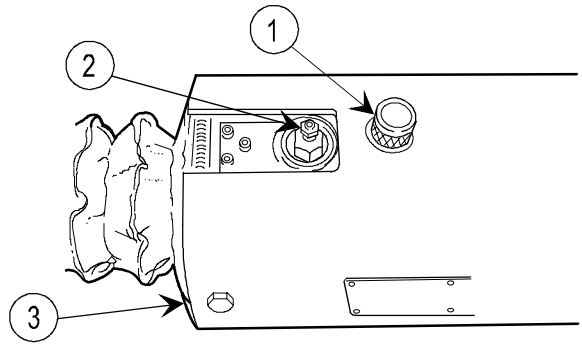

NOTE

Do not open check valves on equilibrator cylinders.

- 3 Remove cap (6) from valve (7).

NOTE

Momentarily open nitrogen tank shutoff valve to clear opening of any debris, prior to attaching nitrogen charging assembly (8) to tank (9).

- 4 Remove protective cover (10) from nitrogen tank (9) and attach nitrogen charging assembly (8) to nitrogen tank (9) and air pressure gage assembly (11).
- 5 Attach air pressure gage assembly (11) to valve (7) of nitrogen hose assembly (4).

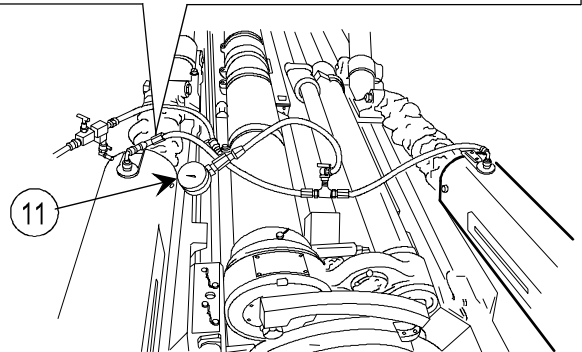
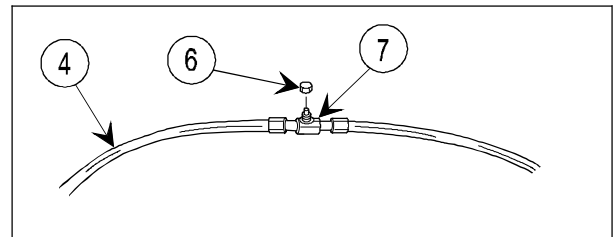

NOTE

Be sure regulator valve on nitrogen charging assembly (8) is closed.

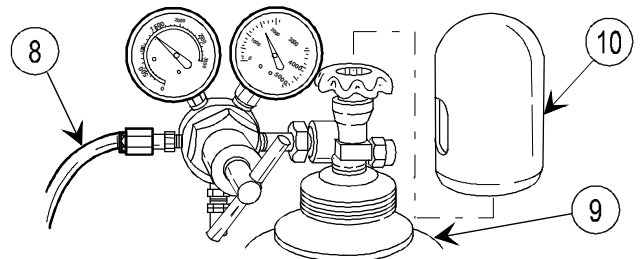

2-60. NITROGEN HOSE ASSEMBLY—MAINTENANCE INSTRUCTIONS (cont)

TESTING (cont)

- 6 Open shutoff valve (12) on nitrogen tank (9). (Pressure gage (13) should indicate a minimum of 2000 psi (13,790 kPa).)
- 7 Open regulator valve (14) of nitrogen charging assembly (8) by turning clockwise until 100 psi (689 kPa) registers on 3000-lb gage (15) and air pressure gage assembly (11).
- 8 Cover all connections of nitrogen hose assembly (4) with soap suds, check for leaks, and tighten as necessary.

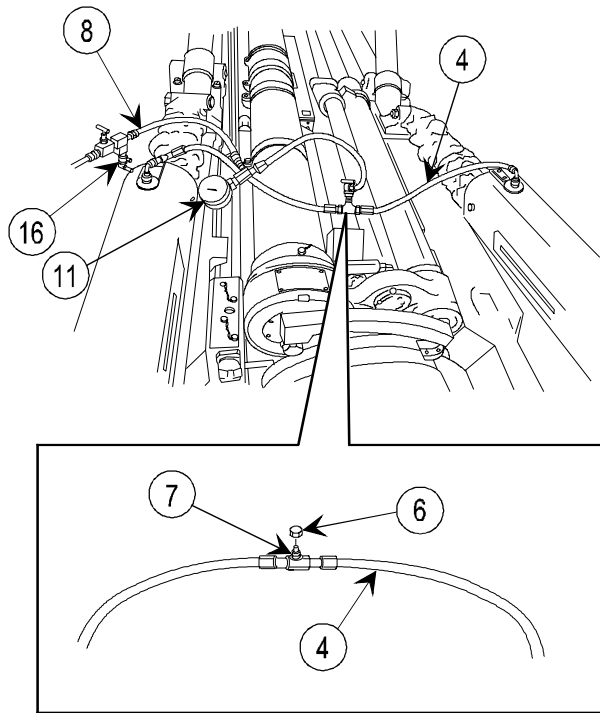

- 9 Turn regulator valve (14) clockwise to increase pressure by 100 psi (689 kPa).
- 10 Repeat steps 8 and 9 until a pressure of 2000 psi (13,790 kPa) is attained and held for 2 minutes without leaking.
- 11 Close shutoff valve (12).
- 12 Open bleed valve assembly (16) of nitrogen charging assembly (8) and bleed out nitrogen until all gages read zero.
- 13 Close regulator valve (14) by turning counter-clockwise.

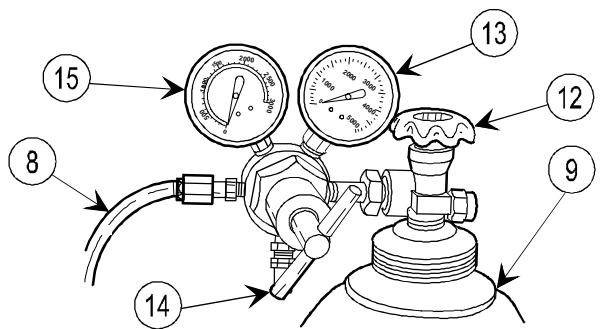

WARNING
Ensure that all pressure gages have returned to zero before proceeding.

- 14 Disconnect and remove nitrogen charging assembly (8) and air pressure gage assembly (11) from nitrogen tank (9) and nitrogen hose assembly (4). Install protective cover (10).
- 15 Install cap (6) on valve (7).

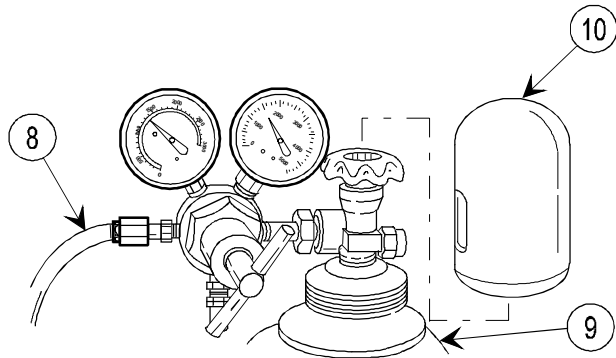

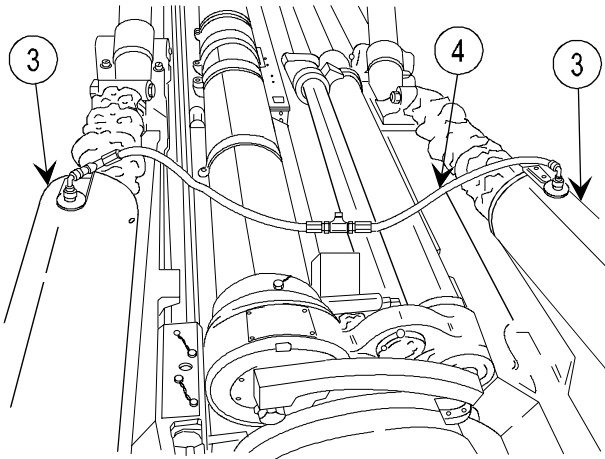

16 Remove nitrogen hose assembly (4) from equilibrator cylinders (3).

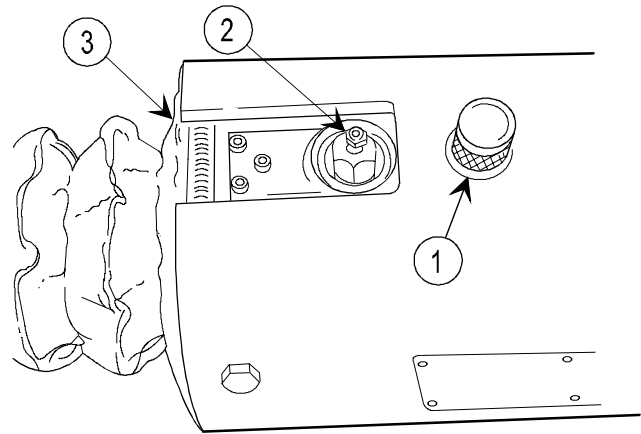

17 Install valve cap (2) and protective dust cap (1) on equilibrator cylinder (3).

2-61. AMMUNITION LOADING TRAY—MAINTENANCE INSTRUCTIONS

THIS TASK COVERS:		
a. Disassembly	b. Inspection/repair	c. Reassembly
INITIAL SETUP		
Tools and Special Tools		
Artillery and turret mechanic's ordnance tool kit (SC 5180-95-CL-A12)		
Artillery field maintenance shop equipment (SC 4933-95-CL-A12)		
Materials/Parts		
Rivet (6) (MS35743-38)		
References		
TM 9-1025-211-34P		

DISASSEMBLY

Remove six rivets (1) and stop (2) from tray (3).

INSPECTION/REPAIR

- 1 Check for broken, missing, or damaged parts.
- 2 Repair is by replacement of authorized parts (TM 9-1025-211-34P).

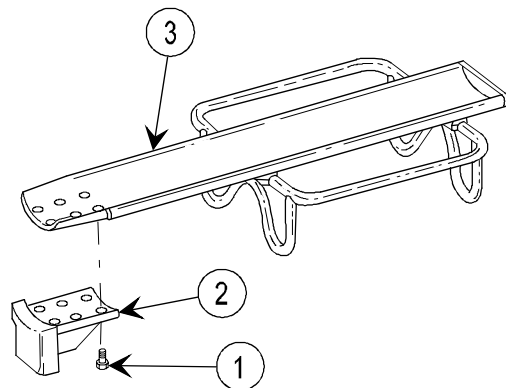

REASSEMBLY

- 1 Install stop (2) and six new rivets (1).
- 2 Grind six rivets (1) flush with inside of tray (3).

2-62. NITROGEN CHARGING ASSEMBLY—MAINTENANCE INSTRUCTIONS

THIS TASK COVERS:			
a. Inspection	b. Disassembly	c. Repair	d. Reassembly
INITIAL SETUP			
Tools and Special Tools Artillery and turret mechanic's ordnance tool kit (SC 5180-95-CL-A12)			
References TM 9-1025-211-34P			

INSPECTION

Inspect gages on regulator (1) for broken glass or bent or broken pointers. Inspect hose assembly (2) for fraying and/or cuts. Inspect valve connection (3) for stripped threads.

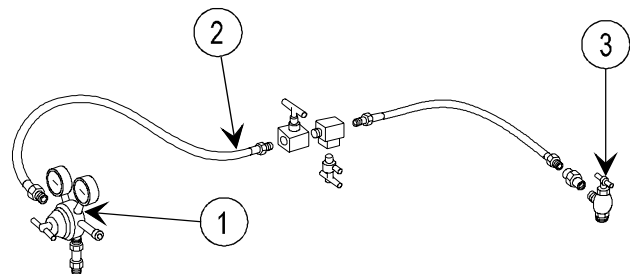

DISASSEMBLY

- 1 Remove regulator (1) from hose assembly (2).
- 2 Remove hose assembly (2) from shutoff valve (3).
- 3 Remove shutoff valve (3) from tee (4).
- 4 Remove bleed valve assembly (5) from tee (4).
- 5 Remove tee (4) from hose assembly (6).
- 6 Remove hose assembly (6) from adapter (7).
- 7 Remove adapter (7) from connection (8).

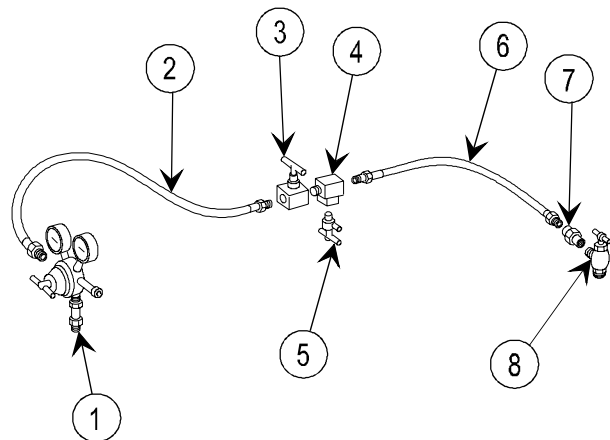

REPAIR

Repair is by replacement of authorized parts (TM 9-1025-211-34P).

REASSEMBLY

- 1 Install adapter (1) on valve connection (2).
- 2 Install hose assembly (3) on adapter (1).
- 3 Install tee (4) on hose assembly (3).
- 4 Install bleed valve assembly (5) on tee (4).
- 5 Install shutoff valve (6) on tee (4).
- 6 Install hose assembly (7) on shutoff valve (6).
- 7 Install regulator (8) on hose assembly (7).

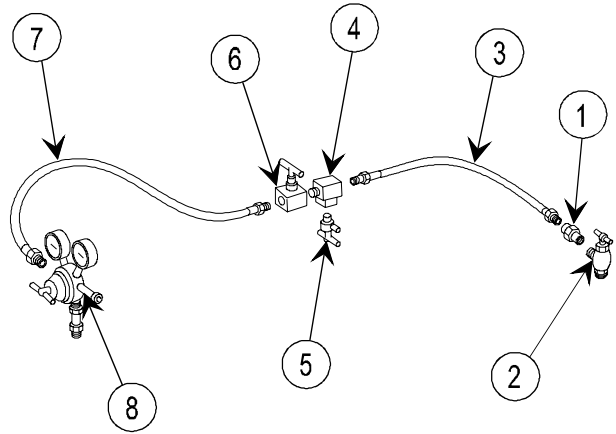

2-63. AIR PRESSURE GAGE ASSEMBLY—MAINTENANCE INSTRUCTIONS

THIS TASK COVERS:			
a. Inspection	b. Disassembly	c. Repair	d. Reassembly
INITIAL SETUP			
Tools and Special Tools Artillery and turret mechanic's ordnance tool kit (SC 5180-95-CL-A12)			
References TM 9-1025-211-34P			

INSPECTION

- 1 Inspect gage (1) on air pressure gage assembly (2) for broken glass or bent or broken pointer.
- 2 Inspect hose assembly (3) for fraying and/or cuts.
- 3 Inspect valve (4) for stripped threads.

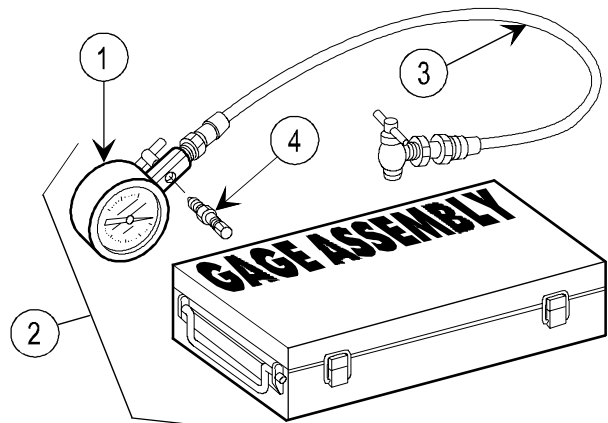

2-63. AIR PRESSURE GAGE ASSEMBLY—MAINTENANCE INSTRUCTIONS (cont)

DISASSEMBLY

Remove valve (1) from hose assembly (2).

REPAIR

Repair is by replacement of authorized parts (TM 9-1025-211-34P).

REASSEMBLY

Install valve (1) on hose assembly (2).

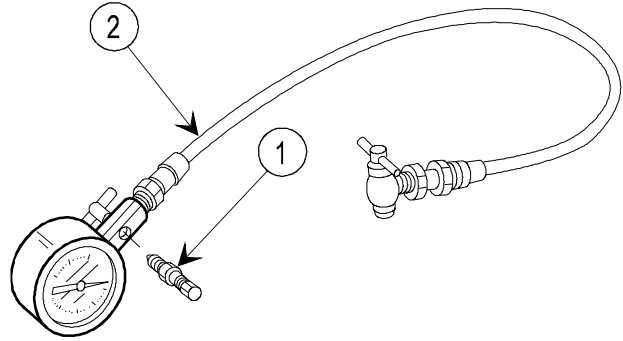

2-64. HINGE PIN PULLER ASSEMBLY—MAINTENANCE INSTRUCTIONS

THIS TASK COVERS:

Inspection/repair

INITIAL SETUP

References
TM 9-1025-211-34P

INSPECTION/REPAIR

- 1 Remove nut (1).
- 2 Remove bolt (2) from body assembly (3).
- 3 Check for broken, damaged, or missing parts.
- 4 Repair is by replacement of authorized parts (TM 9-1025-211-34P).
- 5 Install bolt (2) on body assembly (3).
- 6 Install nut (1).

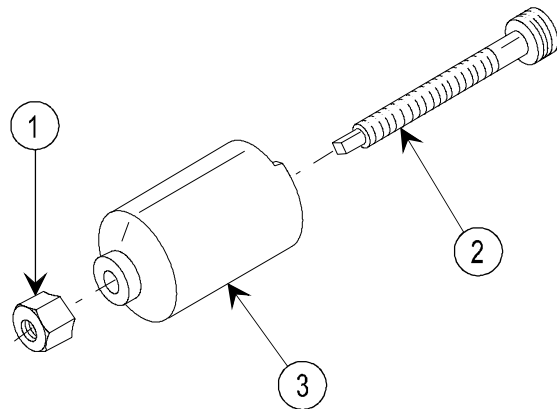

2-65. SAFETY STRUT ASSEMBLY—MAINTENANCE INSTRUCTIONS

THIS TASK COVERS:		
a. Disassembly	b. Inspection/repair	c. Reassembly
INITIAL SETUP		
Tools and Special Tools Artillery and turret mechanic's ordnance tool kit (SC 5180-95-CL-A12)		
References TM 9-1025-211-34P		

DISASSEMBLY

- 1 Remove four nuts (1), four washers (2), and four capscrews (3).
- 2 Remove cap (4) from support (5).
- 3 Remove link (6) from support (5) and pin assembly (7).
- 4 Separate link (8) from pin cable assembly (9) and manual control handle (10).
- 5 Separate two links (11) from manual control handle (10), cable assembly (12), and lock pin (13).

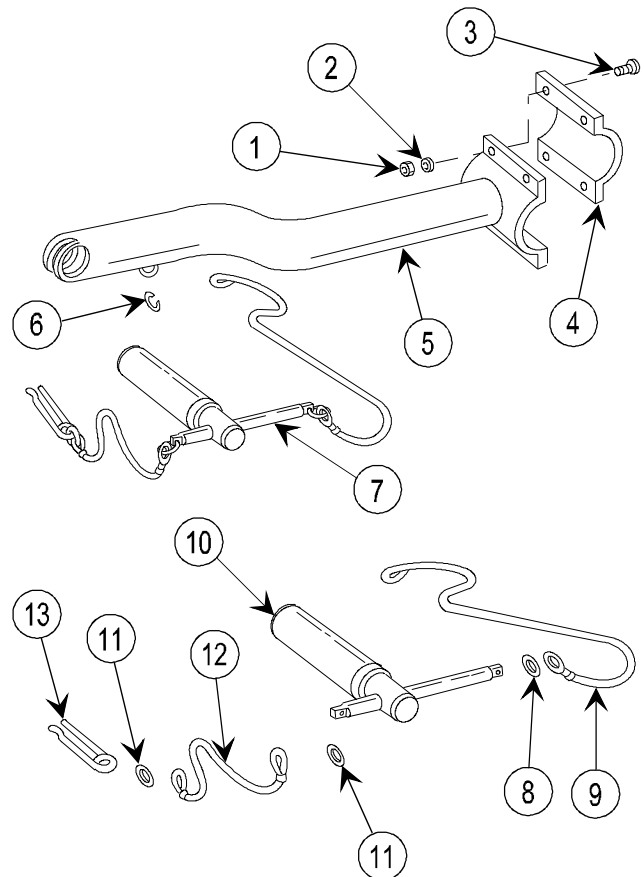

INSPECTION/REPAIR

- 1 Check for broken, damaged, or missing parts.
- 2 Repair is by replacement of authorized parts (TM 9-1025-211-34P).

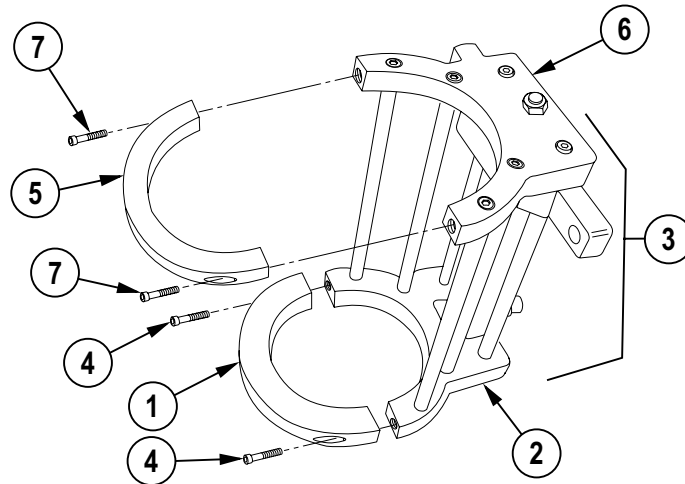

- 1 To inspect lower yoke halves with mounting hardware:
 - a. Install front lower yoke half (1) on front upper yoke half (2) of cylinder support (3) using two bolts (4). Install rear lower yoke half (5) on rear upper yoke half (6) of cylinder support using two bolts (7). Install four bolts (4 and 7) completely to ensure threads are usable.
 - b. When satisfied with fit and function of two lower yoke halves (1 and 5) and bolts (4 and 7), remove items and store according to unit standard operating procedures (SOP).

- 2 To inspect cylinder yoke assembly:

NOTE

Lower yoke halves and attaching bolts are removed for inspection of cylinder yoke assembly.

- a. Place cylinder support (3) on a clean working surface with cylinder assembly (8) located on top.
- b. Remove nut (9) from adapter (10).
- c. Check for smooth movement of cylinder yoke assembly (11) on headless rods (12) by attempting to slide cylinder yoke assembly over full distance of the headless rods. Rods may be cleaned with CLP (item 6.1, appx B) as required.
- d. If binding is present, the two bearing sleeves (13) may be damaged/burred and require replacement or the two headless rods (12) may be damaged/bent and require replacement. Follow disassembly procedures to perform replacements.
- e. Check for evidence of cracks over entire surface of cylinder yoke assembly (11).

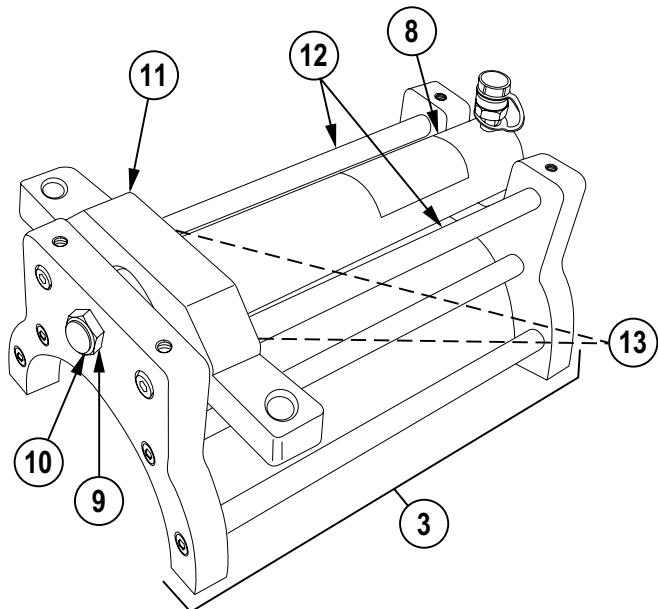

2-65.1. M45 RECOIL MECHANISM EXERCISER—MAINTENANCE INSTRUCTIONS (cont)

INSPECTION (cont)

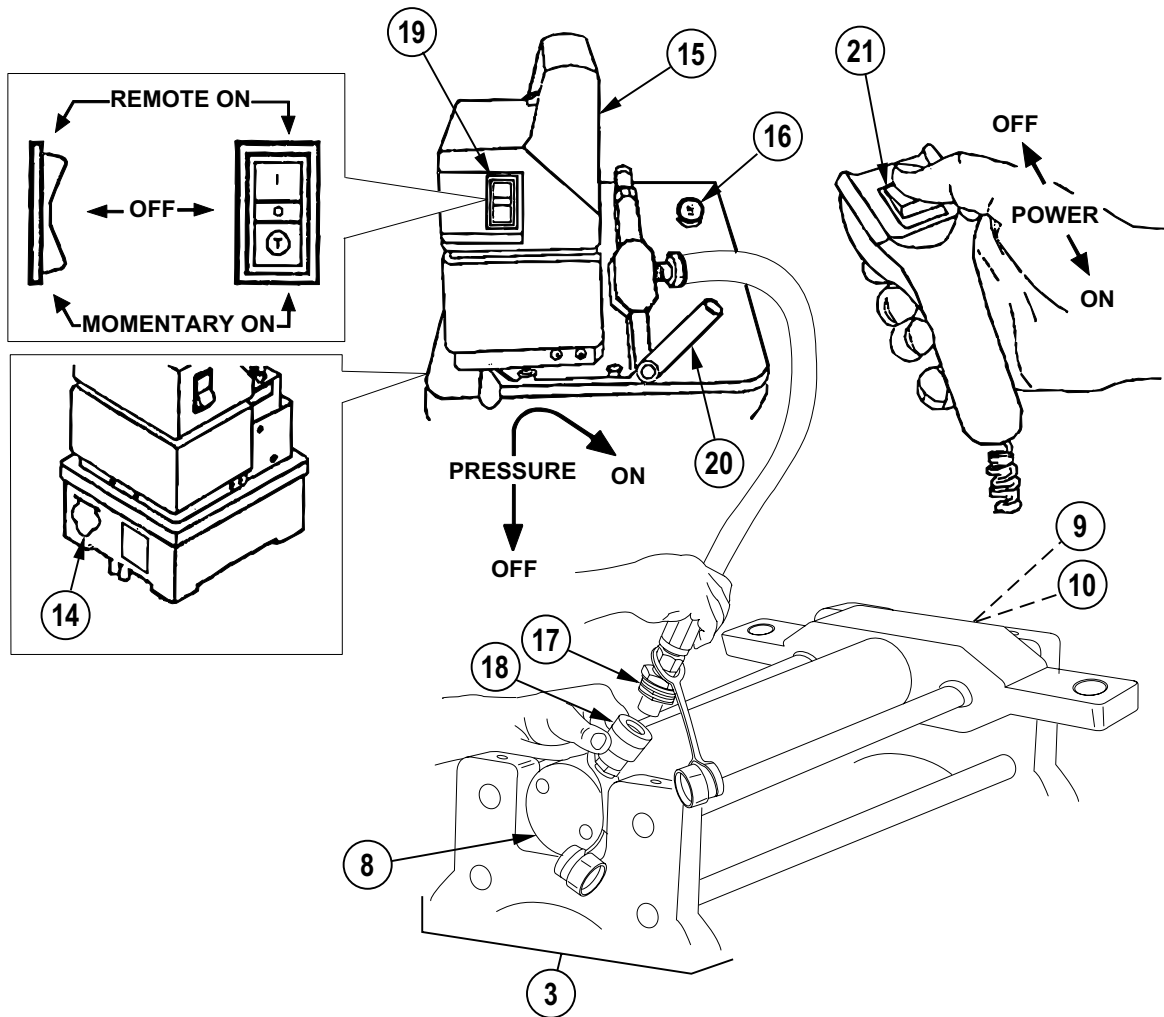

- 3 To inspect cylinder assembly and pump:

WARNING

To prevent injury to personnel, ensure that power switch of pump is in either the OFF position or REMOTE ON position and that the flow lever is in the OFF position (rotated fully counter-clockwise) before connection of electrical power.

- a. Connect electrical extension cord to electrical connection point (14) of pump (15) and plug other end into a suitable electrical wall outlet.

WARNING

To prevent injury to personnel, relieve oil pressure at fill port.

- b. Ensure that oil level in reservoir of pump (15) is within 1/2 in. (1.27 cm) of opening of fill port (16). Open fill port plug one-half turn to allow reservoir to vent.

NOTE

Lower yoke halves and attaching bolts are removed for inspection of the cylinder assembly and pump.

- c. Place cylinder support (3) on a clean working surface with cylinder assembly (8) located on top.
- d. Ensure that nut (9) is installed on adapter (10).
- e. Connect hydraulic hose quick disconnect (17) of pump (15) to the quick disconnect (18) of cylinder assembly (8).
- f. Place power switch (19) of pump (15) in the REMOTE ON position.
- g. Position flow lever (20) of pump (15) to the ON position (rotated clockwise firmly).

WARNING

Do not overextend the cylinder assembly. Injury to personnel or damage to equipment could occur. Pumping time is less when exerciser is not attached to the howitzer.

- h. Press remote control button (21) of pump (15). Allow cylinder assembly (8) to fully extend.
- i. Check all connections and cylinder assembly (8) for evidence of hydraulic leaks.

- j. Check for smooth operation of cylinder yoke assembly (11) sliding over headless rods (12); there should be no evidence of binding.
- k. After functional test, disconnect hydraulic hose quick disconnect (17) from cylinder assembly (8). If no further inspection/disassembly procedures are going to be performed, clean and store pump (15), cylinder support (3), and two lower yoke halves according to unit SOP.

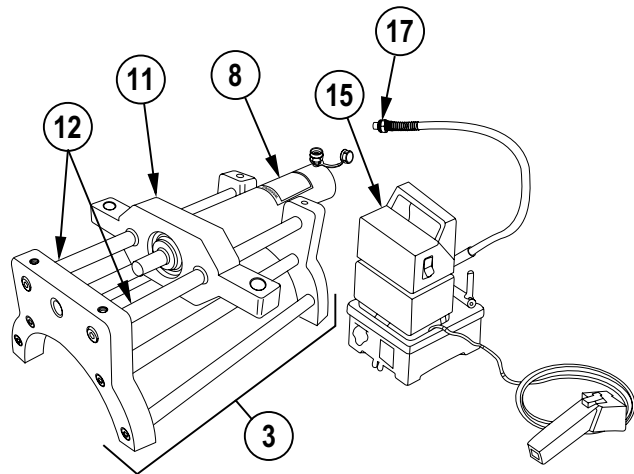

2-65.1. M45 RECOIL MECHANISM EXERCISER—MAINTENANCE INSTRUCTIONS (cont)

INSPECTION (cont)

- I. Align four threaded holes in clamp (22) with four through holes of clamp block (23) and install four screws (24). Tighten screws. When satisfied with form and fit of parts, disassemble and store according to unit SOP.

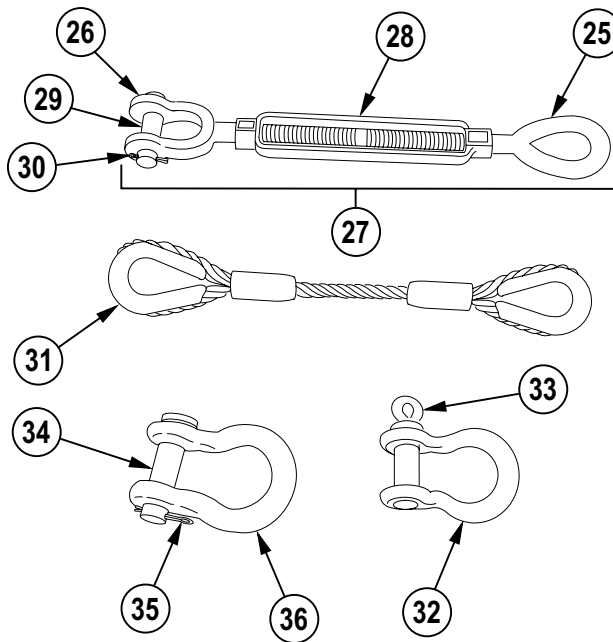
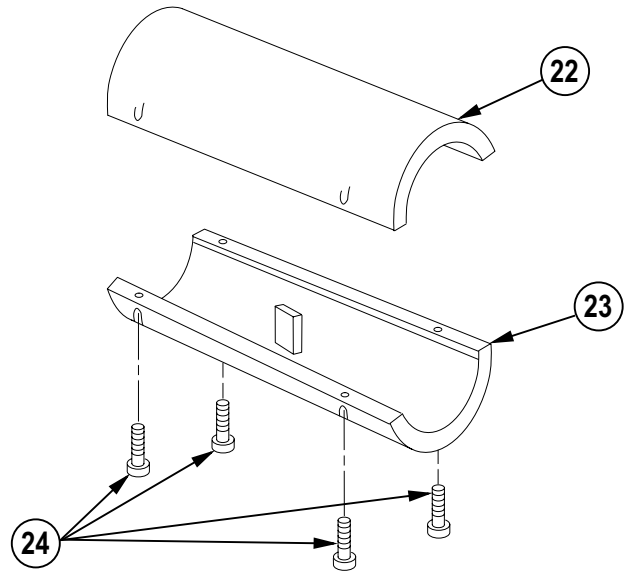

4 To inspect turnbuckles and wire ropes:

- a. Hold eye (25) and shackle (26) of turnbuckle (27) stationary while rotating turnbuckle body (28). Extend until there is approximately 12 in. (30.5 cm) between the threaded ends of the eyes. Apply a light coat of CLP (item 6.1, appx B) to threads. Return eyes to fully retracted position. Repeat for second turnbuckle.
- b. Check for pin (29) and cotter pin (30) in the turnbuckle shackle (26). There should be one of each in each turnbuckle. Ensure cotter pins are not damaged beyond use.

- c. Inspect two wire ropes (31) for frayed or broken wire strands. Wipe with cloth dampened with CLP (item 6.1, appx B).
- d. Inspect the 7/8 in. (2.2 cm) shackle (32) for ease in removing bolt (33). Apply light coat of CLP (item 6.1, appx B) to threads and install bolt into shackle. Repeat for second shackle.
- e. Check for pin (34) and cotter pin (35) in two 1 in. (2.54 cm) shackles (36). There should be one of each in each shackle. Ensure cotter pins are not damaged beyond use.
- f. Upon satisfactory inspection, with no defects found, store items according to unit SOP. If any item is damaged, replace as needed.

DISASSEMBLY

CAUTION

Protect cylinder quick disconnect from damage.

NOTE

During the disassembly process, inspect all hardware for damaged threads. Inspect cylinder support components for any deformities.

- 1 If installed, remove front lower yoke half (1), rear lower yoke half (2), and four bolts (3) from cylinder support (4).
- 2 Place cylinder support (4) on a clean working surface with nut (5) located on top.
- 3 Remove nut (5) from adapter (6).
- 4 Remove four socket head capscrews (7) and two setscrews (8) from rear upper yoke half (9).
- 5 Remove rear upper yoke half (9).

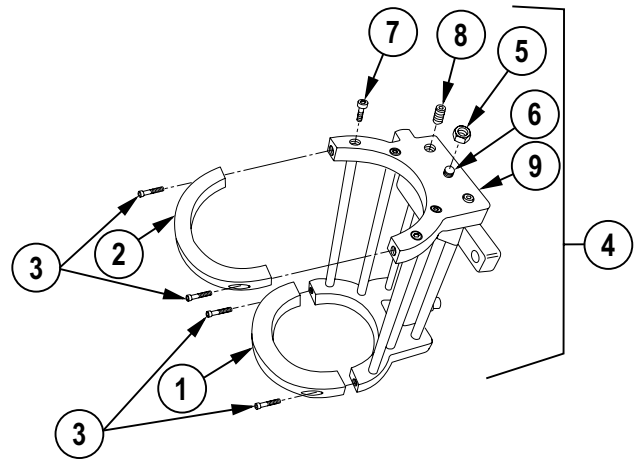

2-65.1. M45 RECOIL MECHANISM EXERCISER—MAINTENANCE INSTRUCTIONS (cont)

DISASSEMBLY (cont)

- 6 Remove adapter (6) from end of cylinder assembly (10).
- 7 Remove assembled cylinder yoke assembly (11) and cylinder assembly (10) from cylinder support (4). Lay cylinder yoke assembly and cylinder assembly on clean working surface.

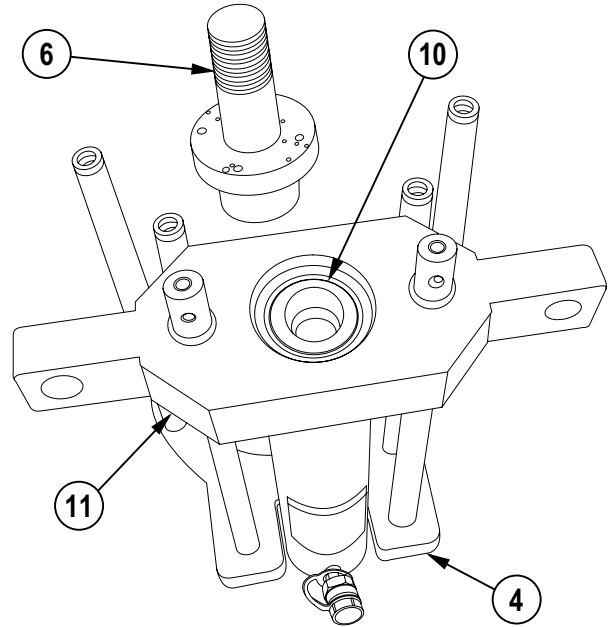

- 8 Loosen plain round nut (12) that secures cylinder yoke assembly (11) on cylinder assembly (10). Remove cylinder yoke assembly and plain round nut from cylinder assembly.

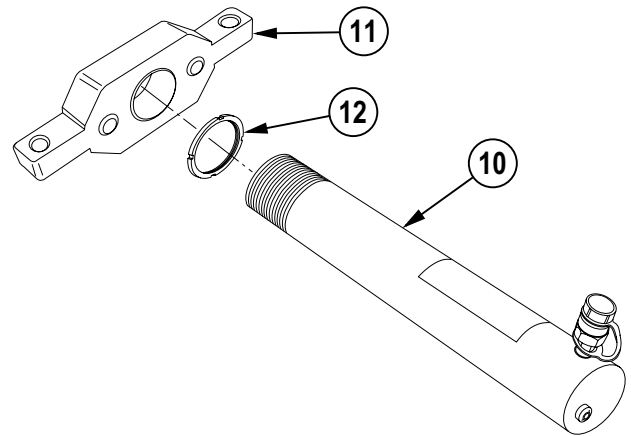

- 9 Remove two setscrews (13) and two headless rods (14) from front upper yoke half (15).
- 10 Remove four socket head capscrews (16) and four threaded standoffs (17) from front upper yoke half (15).

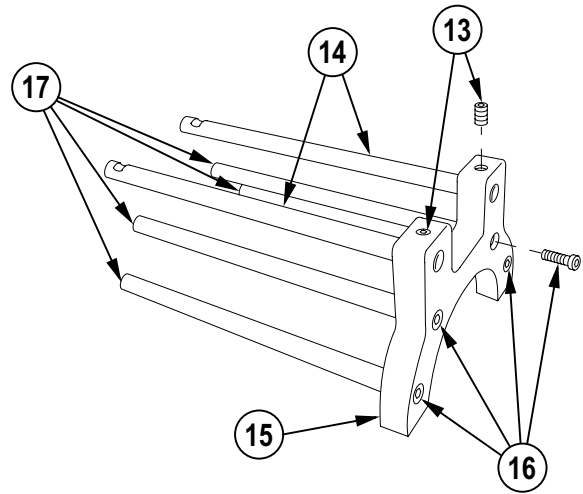

NOTE

Removal of the quick disconnect, protective cap, and the two bearing sleeves should be performed only if the inspection process indicates damage.

- 11 If damaged, remove quick disconnect (18) and protective cap (19) from cylinder assembly (10).
- 12 If either of the two bearing sleeves (20) fail inspection, remove the defective bearing sleeve(s) from cylinder yoke assembly (11).

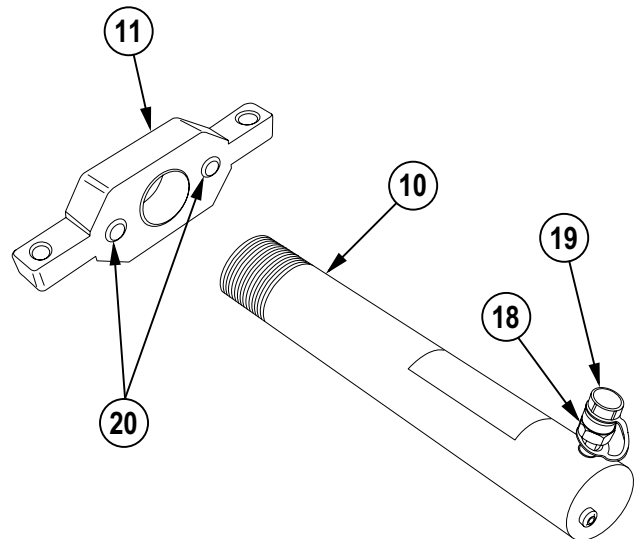

REASSEMBLY

- 1 If removed, wrap threads of new quick disconnect (1) with antiseizing tape (item 32, appx B) and install quick disconnect and protective cap (2) into cylinder assembly (3).

CAUTION

Freeze bearing sleeves prior to installation; damage may occur due to press fit dimensioning.

- 2 If removed, lubricate new bearing sleeve(s) (4) and hole(s) in cylinder yoke assembly (5). Install bearing sleeve(s) into cylinder yoke assembly.

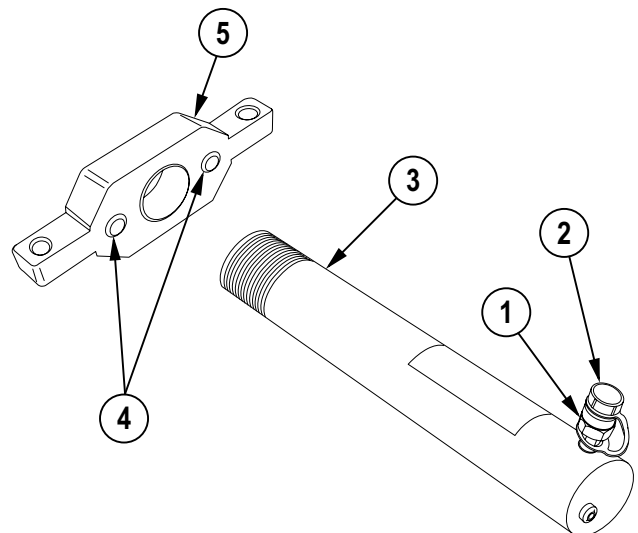

2-65.1. M45 RECOIL MECHANISM EXERCISER—MAINTENANCE INSTRUCTIONS (cont)

REASSEMBLY (cont)

3 Align four threaded standoffs (6) with four holes in front upper yoke half (7). Install four socket head capscrews (8) through countersunk bores of front upper yoke half and into threaded standoffs. Tighten socket head capscrews.

4 Align and install two headless rods (9) with two holes in front upper yoke half (7). Rotate headless rods until locating flats (10) are visible through setscrew holes. Install two setscrews (11) into front upper yoke half until contact is made with locating flats. Do not tighten setscrews at this time.

5 Install plain round nut (12) onto threaded end of cylinder assembly (3). Ensure that plain round nut is installed onto the full distance of the cylinder threads.

6 Install cylinder yoke assembly (5) onto cylinder assembly (3) until cylinder yoke assembly comes in contact with plain round nut (12). Position cylinder yoke assembly to be at 90 degree angle to quick disconnect (1). Do not tighten plain round nut at this time.

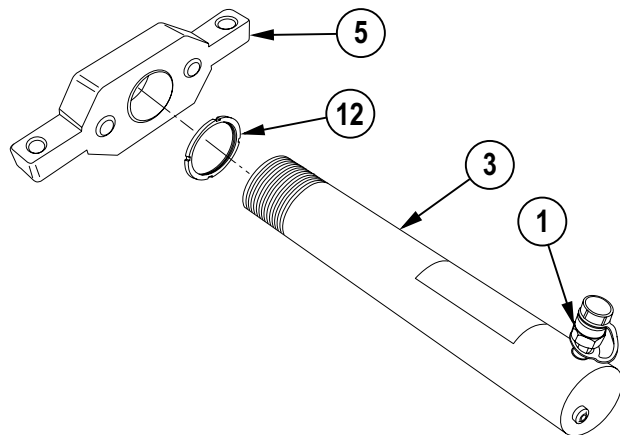
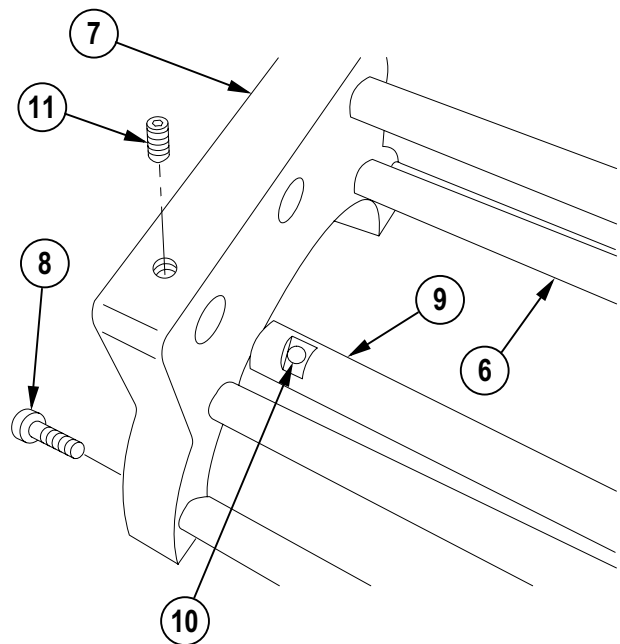

7 Position front upper yoke half (7) with attached rods pointing up. Position quick disconnect (1) on cylinder assembly (3) to face away from front upper yoke half. Align two bearing sleeves (4) with two headless rods (9) and install cylinder yoke assembly (5) onto headless rods.

8 Install adapter (13) into cylinder assembly (3) and tighten.

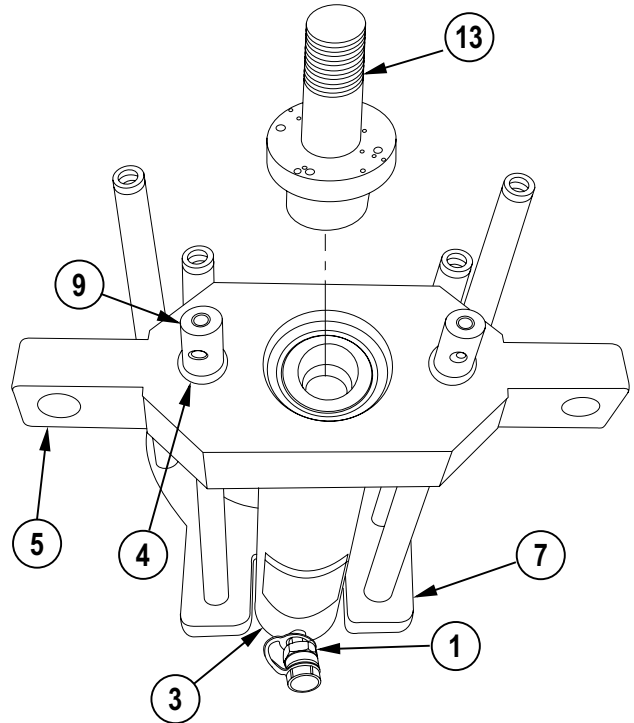

9 With the countersunk bolt holes of rear upper yoke half (14) pointing up, align bolt holes with four threaded standoffs (6) and headless rods (9) and install rear upper yoke half onto standoffs and rods.

10 Install four socket head capscrews (15) through rear upper yoke half (14) and into four threaded standoffs (6). Tighten socket head capscrews.

11 Install two setscrews (16) into rear upper yoke half (14). Tighten four setscrews (16 and 11) in the front upper and rear upper yoke halves (7 and 14).

12 Install nut (17) on adapter (13).

13 Ensure quick disconnect (1) is positioned at 90 degree angle from cylinder yoke assembly (5). Tighten plain round nut (12).

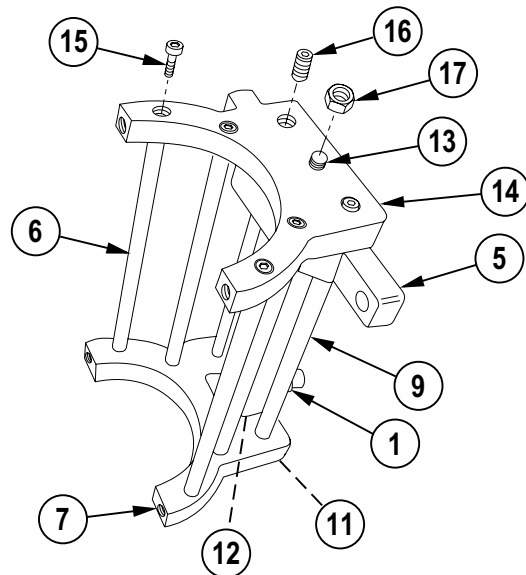

Section VII. M198 HOWITZER—MAINTENANCE INSTRUCTIONS

Section Index

Paragraph		Page
2-66.	M198 Howitzer—Maintenance Instructions	2-396.10

2-66. M198 HOWITZER—MAINTENANCE INSTRUCTIONS

THIS TASK COVERS:

- | | |
|---------------------------|----------------------------------|
| a. Leveling the trunnions | b. Leveling the M199 cannon tube |
| c. Boresighting | d. Synchronization |

INITIAL SETUP

Tools and Special Tools

- Breech boresight disk (10544480)
- Fabricated boresight target (page 2-400)
- Mechanical screw jack (2) (GGG-J-51)
- M198 field artillery repairman tool kit (5911278)
- Instrument and fire control shop equipment (SC 4931-95-CL-A07)
- Instrument and fire control system repair shop equipment (SC 4931-95-CL-A09)
- Wood blocking available

Materials/Parts

- Fibrous cord (item 10, appx B)
- PL-S (item 15, appx B)
- Sealing compound (item 26, appx B)
- Tape, antiseizing (item 32, appx B)

References

- TM 9-1025-211-10
- TM 9-1025-211-20&P
- TM 9-1240-375-34

Personnel Required: 2

- Fire control instrument repairer

Equipment Conditions

- 500-lb (227-kg) weights available (2)
- M137 panoramic telescope installed (TM 9-1025-211-10)
- M138 elbow telescope installed (TM 9-1025-211-10)
- M139 alinement device comparison test performed (TM 9-1025-211-10)

General Safety Instructions

WARNING

All lifting devices must be checked in accordance with local Standing Operating Procedure (SOP) to make sure they are in good working condition before starting the lifting operation.

NOTE

The maintenance procedures in this paragraph must be performed in sequence each time the M199 cannon assembly or cannon tube, the M45 recoil mechanism, the M171 or M172 telescope and quadrant mounts, or adapter or adapter assembly is replaced. The procedure must also be completed if a discrepancy exists between the M139 alinement device and the M137 panoramic telescope.

LEVELING THE TRUNNIONS

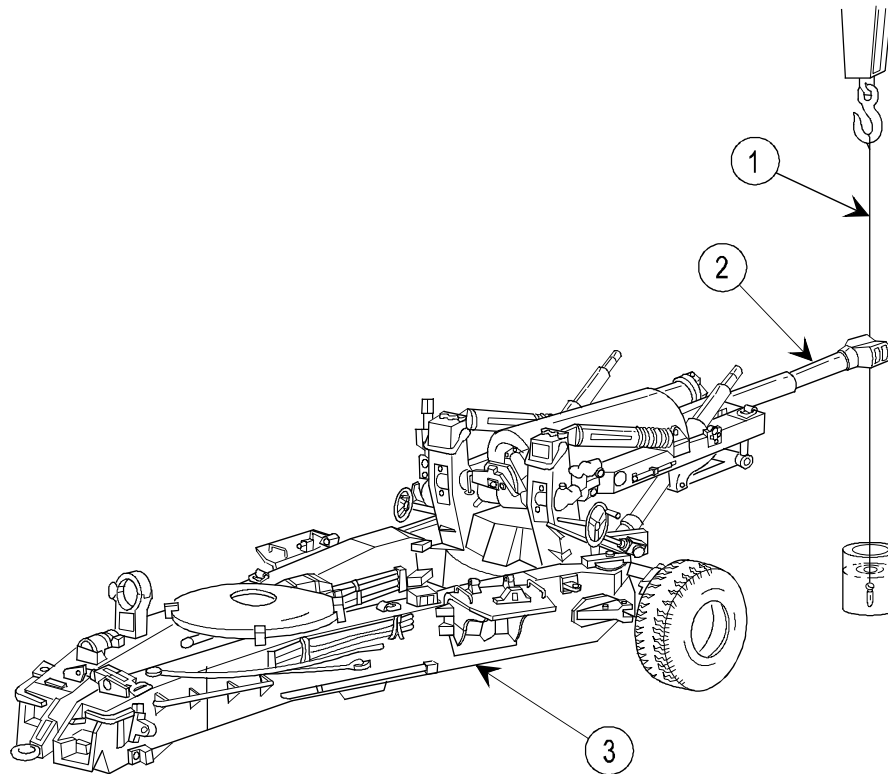

WARNING

Check nitrogen pressure prior to performing procedures for leveling trunnions. If nitrogen pressure is below 800 psi (5516 kPa), the cannon and recoil mechanism could slide out of battery causing serious personal injury. Make sure all personnel are clear of cannon recoil path until pressure is checked and reestablished, if necessary.

NOTE

Plumbline is made from fibrous cord.

Plumbline shall be weighted with at least 5 lbs (2 kg). The weight shall be suspended and immersed in a container of PL-S oil. Shield plumbline from air currents if possible.

- 1 Attach plumbline (1) to a fixed object which is high enough that it can be seen when cannon tube (2) is elevated to 978 mils.

NOTE

If an object of sufficient height is not available to attain the 978-mil elevation requirement, a minimum of 600 mils may be used.

- 2 Position howitzer (3) on as firm and level ground as possible.

NOTE

Tube must be at zero elevation when positioning plumbline.

- 3 Position so that muzzle end of cannon tube (2) is 1.0 ft (0.3 m) or less from plumbline (1) with howitzer at zero elevation.

2-66. M198 HOWITZER—MAINTENANCE INSTRUCTIONS (cont)

LEVELING THE TRUNNIONS (cont)

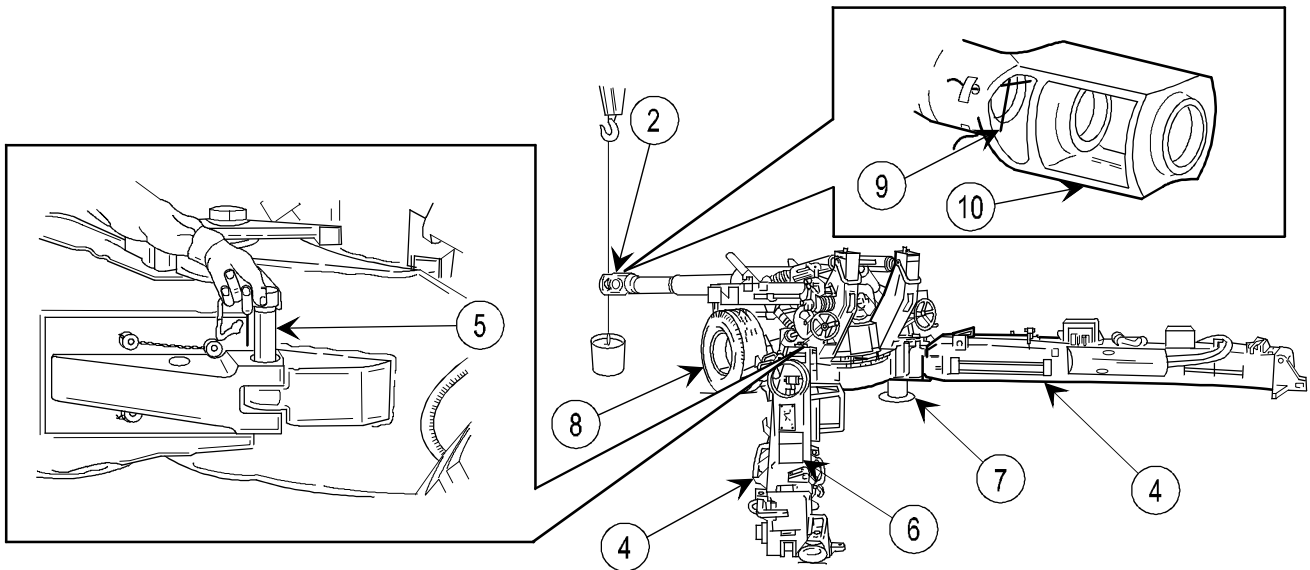

- 4 Spread trails (4) and lock in position with tapered plugs (5).

WARNING

The howitzer's balance center line changes when set on the mechanical screw jacks. If sufficient weights are not placed on the trails, elevation/depression of the M199 cannon could cause the howitzer to topple and cause personal injury.

NOTE

Free ends of trails should be cross leveled within 2 in. (5 cm). Lift low trail and place on wood blocking as required to achieve this condition.

- 5 To each trail, add one weight, weighing approximately 500 lb (227 kg), as close as possible to the open end of the trail.

NOTE

Mechanical screw jacks must have a minimum base of 1.00 square foot (0.09 square meters).

- 6 Place two mechanical screw jacks (7) under middle of right and left side of bottom carriage directly under axle.

NOTE

Wheels must be completely off the ground.

- 7 Raise wheels (8) to lower bottom carriage onto mechanical screw jacks (7).
- 8 Elevate or depress cannon tube (2) to zero mils using gunner's quadrant.

NOTE

Fibrous cord used to form crosshairs must be alined with four witness marks on muzzle end.

- 9 Install crosshairs (9) in muzzle brake (10) and secure with suitable tape.

NOTE

Traversing the weapon is always performed at zero elevation.

- 10** Install breech boresight disk (11) in breech. Manually traverse weapon left or right as necessary to align vertical crosshair and plumbline. Binoculars may be used when sighting on crosshair and plumbline and when sighting on boresight target.

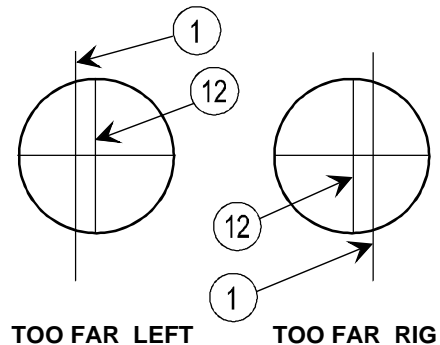
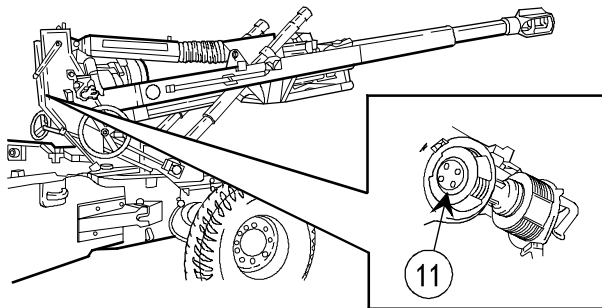
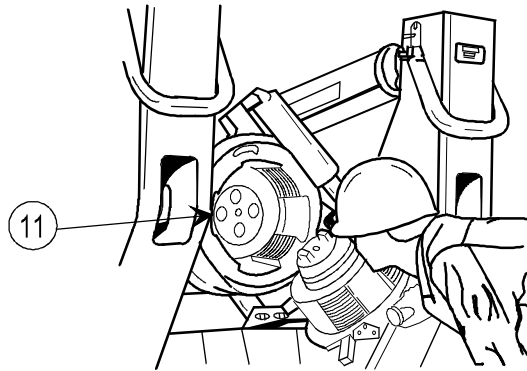

CAUTION

Raising the mechanical screw jacks is always performed with the weapon at maximum elevation; if not, the weapon could teeter and possibly cause the muzzle brake to strike the ground.

- 11** Observe plumbline (1) through breech boresight disk (11) while elevating cannon tube from 0 mil to maximum elevation.

NOTE

If vertical crosshair (12) moves to right of plumbline (1), raise the right mechanical screw jack until crosshair centers on plumbline.

If vertical crosshair (12) moves to left of plumbline (1), raise the left mechanical screw jack until crosshair centers on plumbline.

- 12** Raise jack to center crosshair (12) on plumbline (1).
- 13** Lower howitzer to zero elevation.
- 14** While sighting through breech boresight disk, traverse howitzer to recenter the crosshair (12) on plumbline (1).

NOTE

Repeat steps 11 thru 14 several times until vertical crosshair tracks plumbline throughout the full range of 0 mil to maximum elevation.

The trunnions are now level. Do not traverse the howitzer until boresighting is completed. If howitzer is traversed, trunnions will no longer be leveled.

2-66. M198 HOWITZER—MAINTENANCE INSTRUCTIONS (cont)

LEVELING THE M199 CANNON TUBE

- 1 Depress cannon tube (1) to below zero elevation.

NOTE

Be sure cannon tube leveling pads are clean.

Gunner's quadrant (2) should be placed on top set of machined pads on cannon tube (1). Be sure to include gunner's quadrant correction, if any, when setting mils elevation in quadrant.

- 2 Set M1A1/M1A2 gunner's fire control quadrant (2) reading to zero and place on leveling pads (3) with LINE OF FIRE arrow pointing toward muzzle end.
- 3 Elevate cannon tube (1) until bubble (4) in M1A1/M1A2 gunner's fire control quadrant is centered.

NOTE

The cannon tube is now level.

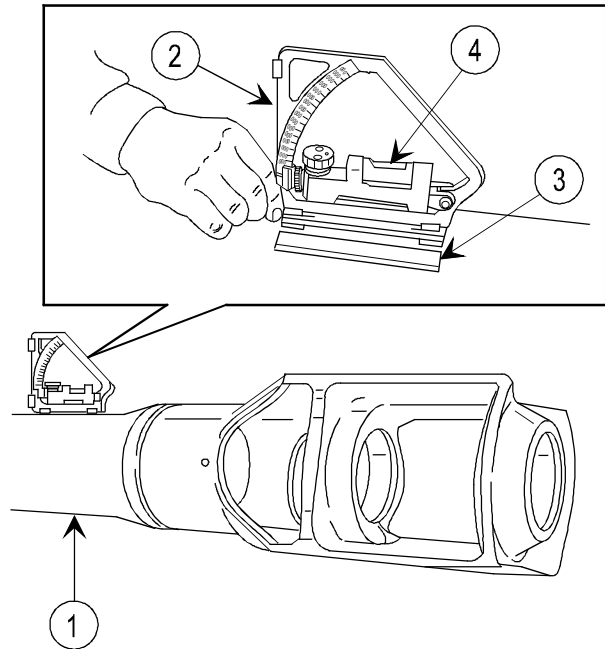

BORESIGHTING

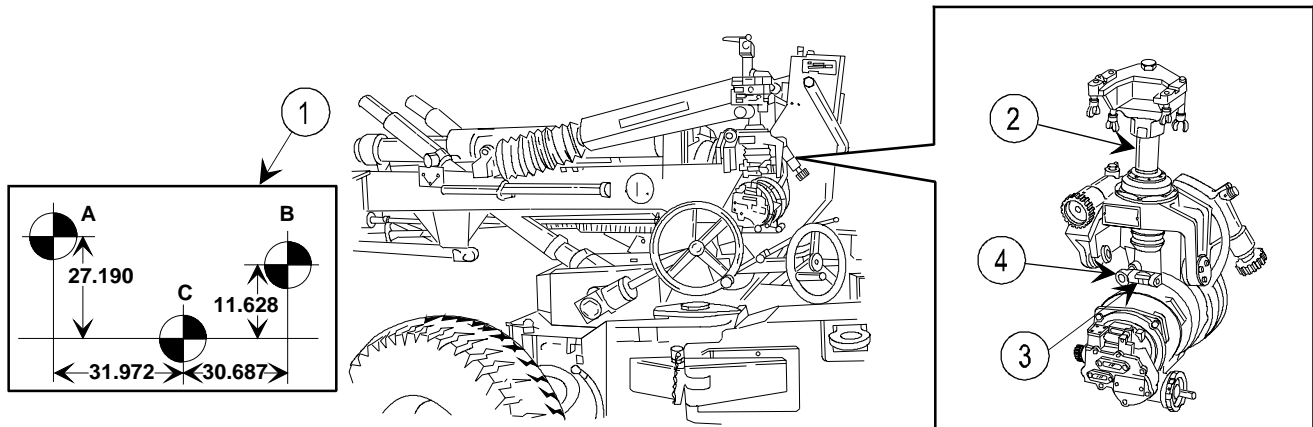

NOTE

Measurements do not appear on target. Measurements may be used to manufacture a target.

Target must be 50 meters in front of the weapon and perpendicular to the trunnions. Once the trunnions are level, do not traverse weapon to center target.

- 1 Sight through breach boresight disk and manually move target until crosshairs of cannon tube are centered on point C of test target (1).
- 2 Check M171 mount (2) to be sure bubbles in pitch level vial (3) and cross level vial (4) are centered.

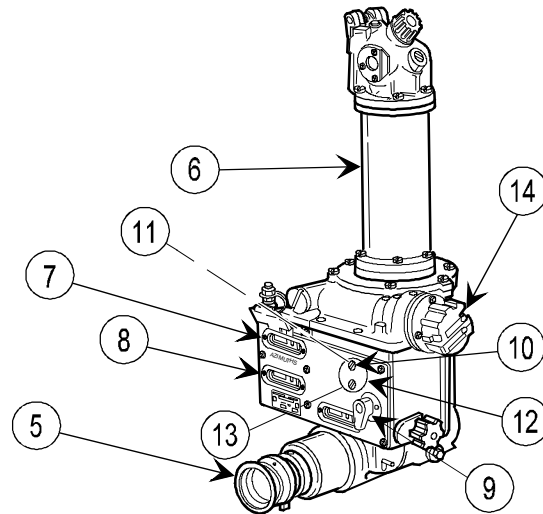

NOTE

A parallax shield may be required to eliminate all parallax on the M137 pantel.

- 3 While looking through the eyepiece (5) on the M137 pantel (6), align reticle crosshairs on target point A.
- 4 Check azimuth counter (7) and deflection counter (8) for readings of 3200 mils. If readings are not 3200 mils, perform the following:

NOTE

Final movement of azimuth knob when making any setting should be in a clockwise direction.

- a. Set deflection counter (8) to 3200 mils.
- b. Move knob (9) to the release position and reset azimuth counter (7) to 3200 mils.
- c. Move knob (9) to the engage position and check to see that both counters are at 3200 mils. If not, repeat above steps.
- d. Remove two screws (10), two lockwashers (11), and cover (12) to gain access to the slotted eccentric (13).
- e. Release the slotted eccentric (13) by turning clockwise.

NOTE

Final movement of azimuth knob when making any setting should be in a clockwise direction.

- f. Rotate azimuth knob (14) on M137 pantel until reticle crosshair is centered on target A.
- g. Engage slotted eccentric (13) by turning counterclockwise.
- h. Repeat steps e thru g to ensure azimuth counter stays on 3200 mils when the M137 pantel reticle crosshair is centered on target A.
- i. Replace cover (12), two lockwashers (11), and two screws (10). Apply sealing compound to screws.

2-66. M198 HOWITZER—MAINTENANCE INSTRUCTIONS (cont)

BORESIGHTING (cont)

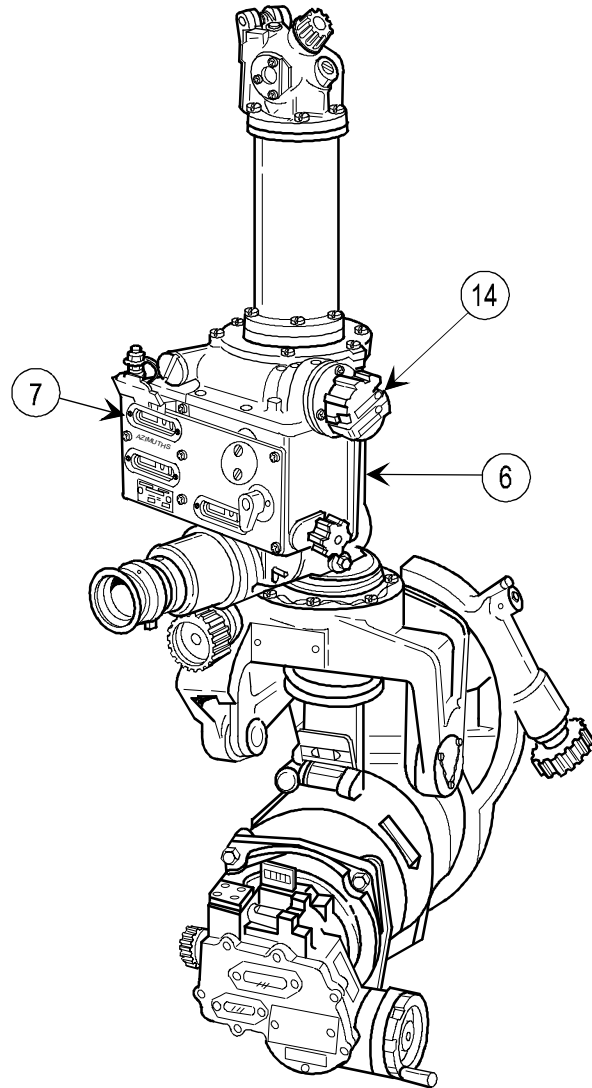
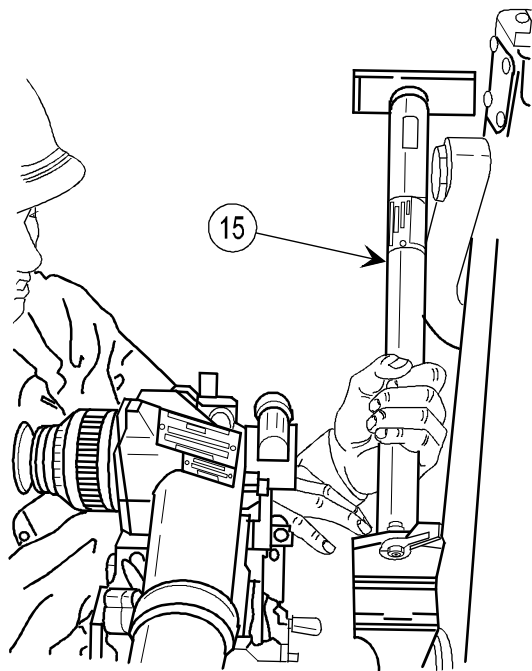
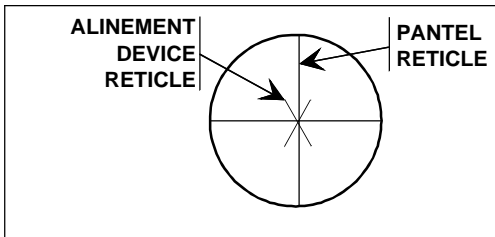

- 5 Ensure M139 alinement device (15) passes the M139 alinement device comparison test (TM 9-1025-211-10) or has been repaired by general support fire control shop; then install on weapon.
- 6 Sight through M137 pantel (6) and rotate azimuth knob (14) until vertical crosshair in pantel aligns with "X" of M139 alinement device. The azimuth counter (7) should read 4800 mils \pm 0.5 mil. If so, go to step 7. If not, go to step 6.1.
- 6.1 Remove M139 alinement device. Remove M172 mount and check the adapter assembly according to the installation and shimming procedure (p 3-5). If the adapter assembly is installed correctly, proceed to step 6.2. If not, shim accordingly and then proceed to step 6.2.

- 6.2** Reinstall the M172 mount and M18 quadrant. Perform steps 1 through 5 of the boresighting procedure. Rotate the azimuth knob (14) on the M137 pantel (6) until the azimuth counter (7) reads exactly 4800 mils. Sight through the M137 pantel and see if the vertical crosshair in the pantel aligns with the "X" of the M139 alinement device. If the crosshairs aline ± 0.5 mil, proceed to step 7. If alinement is still out of tolerance, proceed to step 6.3.
- 6.3** If the vertical crosshairs of the M137 pantel are to the left of the "X", shim the left top support stud of the adapter assembly using minimal increments. If the vertical crosshairs of the M137 pantel are to the right of the "X", shim the right top support stud of the adapter assembly using minimal increments. Recheck alinement and continue to shim until alinement is within tolerance. Once tolerance of alinement is achieved, proceed to step 7.
- 7** Remove M139 alinement device (15).

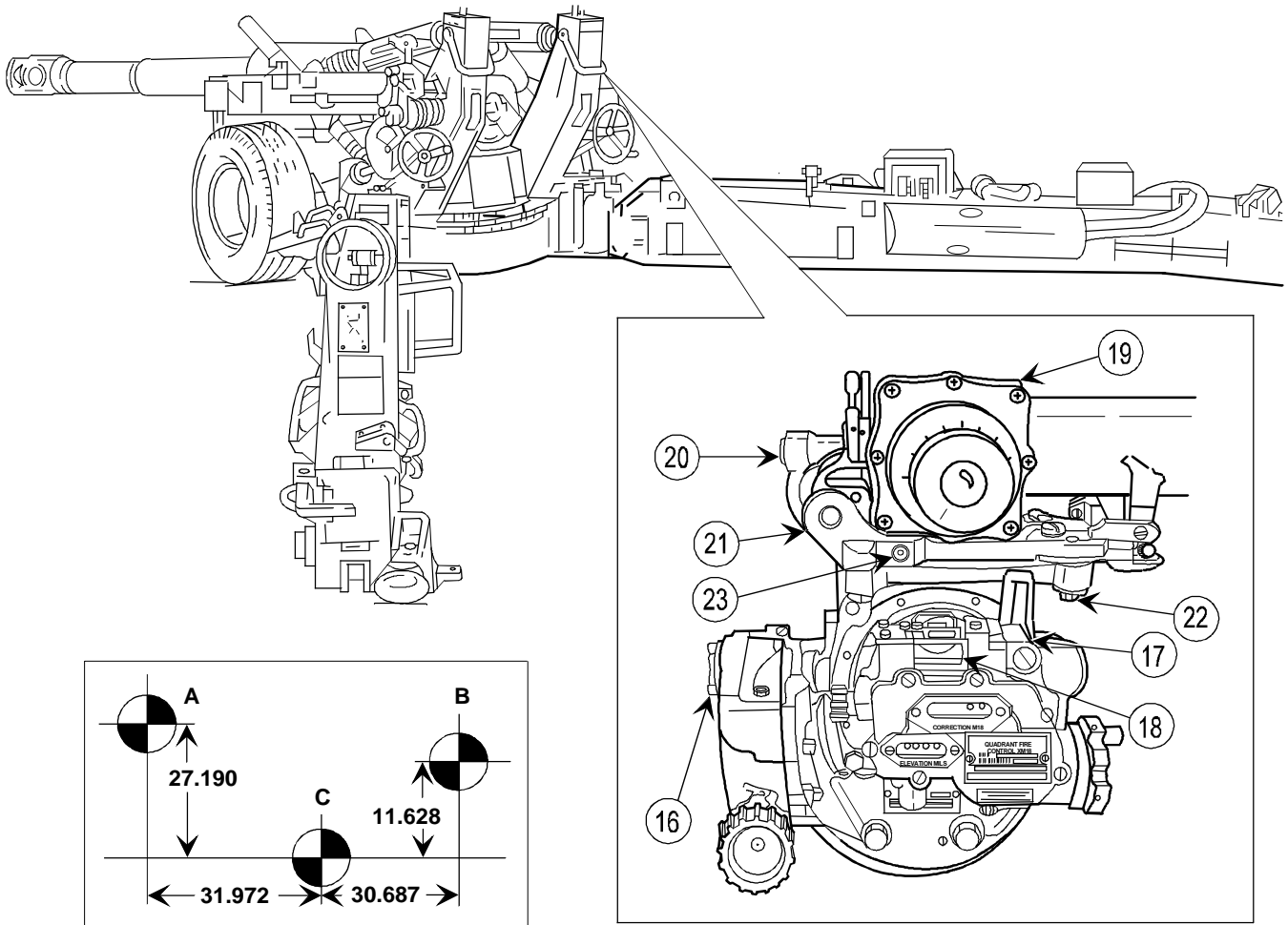

NOTE

A parallax shield may be required to eliminate all parallax between the M138 elbow telescope and the test target.

Final movement of knobs must be in clockwise direction when leveling the level bubbles.

- 8 Cross level M172 mount (16) by centering bubbles in the cross level vial (17) and the elevation level vial (18) on the M18 quadrant.
- 9 Check that the reticle crosshairs on M138 elbow telescope (19) align with target B.
 - a. If elevation must be adjusted, rotate the elevation adjusting screw (20) on the mounting bracket (21) of the M172 mount (16).
 - b. If azimuth must be adjusted, loosen four capscrews (22) securing mounting bracket to M172 mount (16). Loosen and/or tighten two capscrews (23) located toward the rear of the mounting bracket. When correction is achieved, retighten four capscrews (22).
 - c. Check to make sure that crosshair is still on target B. If not, repeat steps a and b.

2-66. M198 HOWITZER—MAINTENANCE INSTRUCTIONS (cont)

SYNCHRONIZATION

NOTE

Before beginning the synchronization procedures, ensure the cannon tube is 0-mil elevation, using the gunner's quadrant.

Final movement of elevation worm gears in M17 or M18 quadrants for any tests or settings being performed should be in a clockwise direction to eliminate backlash.

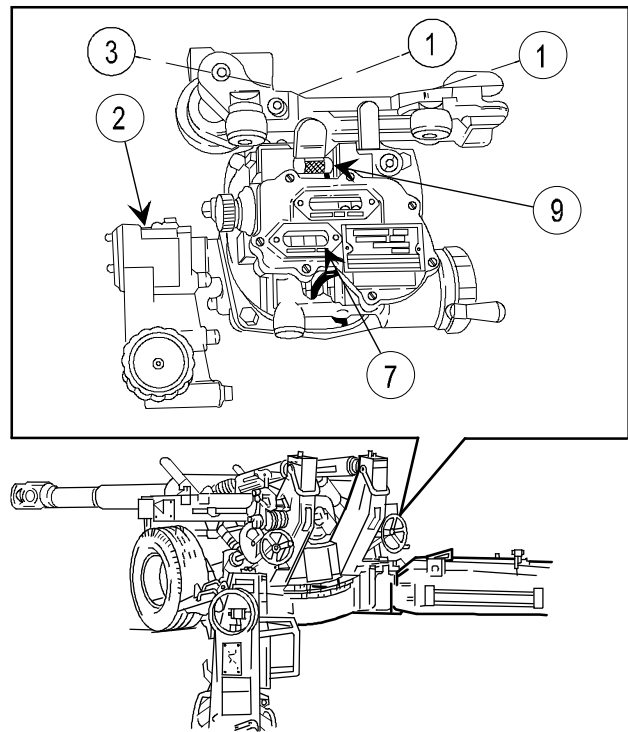
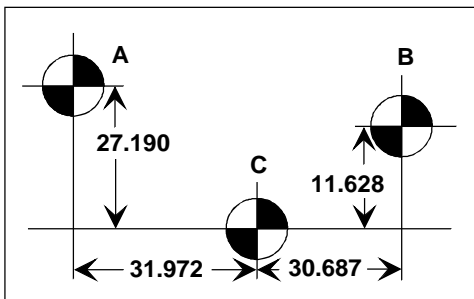

- 1 Ensure mounting pads (1) on M172 mount (2) are parallel with cannon tube within ± 0.2 mil. If not parallel, adjust eccentric (3) (TM 9-1240-375-34).
- 2 Ensure that bubbles in cross level vial (4) and pitch level vial (5) on M171 mount to ensure bubbles are centered and that crosshairs in reticle of M137 pantel are alined with target A or other defined target if synchronization is not performed in conjunction with boresighting.
- 3 Set M17 and M18 elevation counters (6 and 7) to zero, with backlash removed.
- 4 Ensure that elevation level vials (8 and 9) are centered. If not, adjust (TM 9-1025-211-20&P).
- 5 Elevate cannon tube from 0 to 1275 mils in 200-mil increments while performing the following:

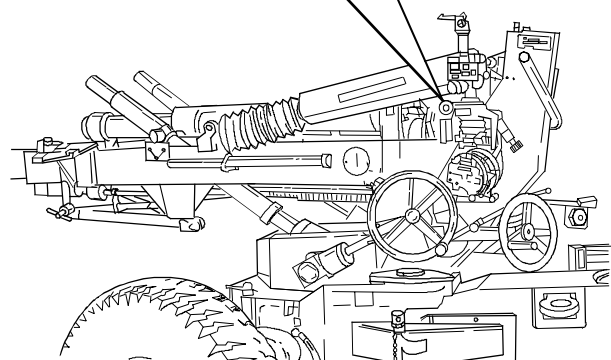
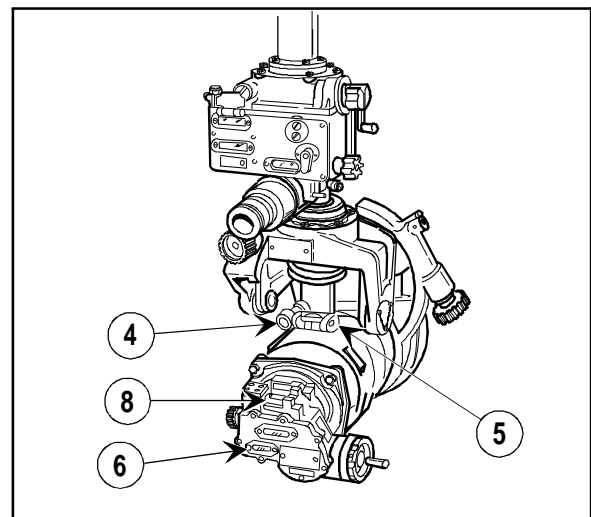

NOTE

The following checks for the M171 mount and the M17 and M18 quadrants may be performed simultaneously. Checks may be made using the M1A1/M1A2 gunner's fire control quadrant placed on the mounting pads of the M172 mount.

- a. Check the elevation counters of the M17 and M18 quadrants. Counters should reflect cannon tube elevation and should not deviate ± 1.0 mil.
- b. Elevate cannon tube in 200-mil increments. Relevel the M171 mount in pitch for each 200-mil step. The vertical crosshair in the M137 pantel should not deviate from the vertical line on target A by more than ± 0.5 mil from 0 to 899 mils elevation, and not more than ± 1.5 mils from 900 to 1275 mils elevation.

NOTE

If deviation exceeds ± 0.5 mil from 0 to 899 mils elevation or ± 1.5 mils from 900 to 1275 mils elevation, the M137 telescope reticle line must be brought in coincidence with center line of target A. To accomplish this, perform the following steps. Perform step c while howitzer is at maximum elevation.

- c. Rotate the cross level knob (10) clockwise and stop when coincidence is obtained.

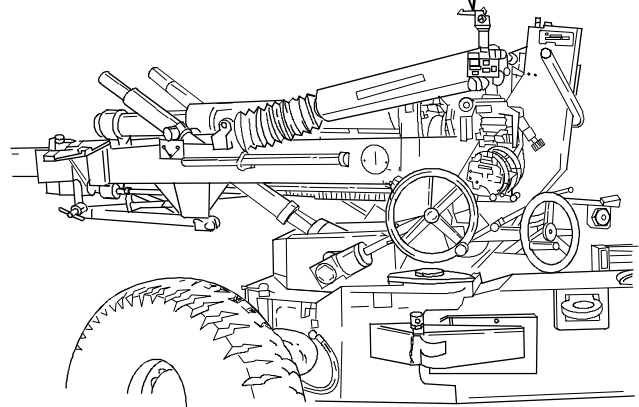
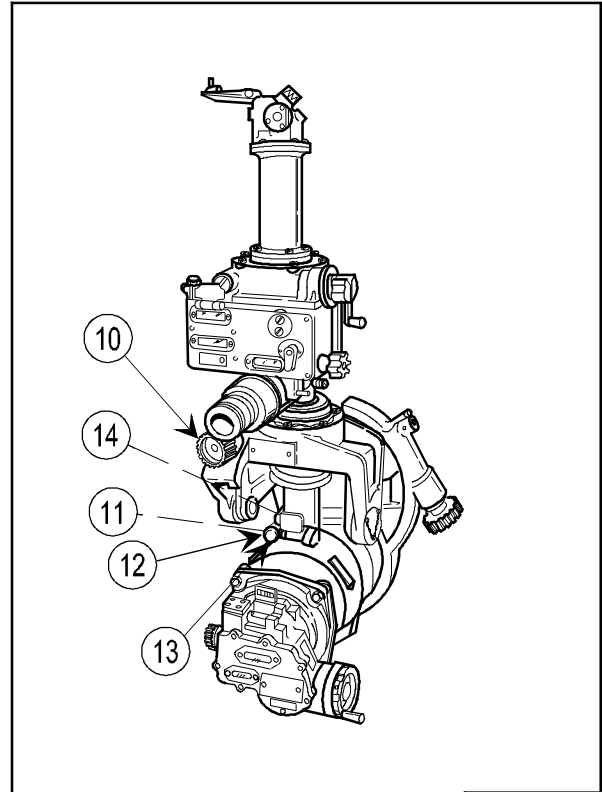

- d. Return cannon tube to 0-mil elevation.
- e. Remove sealing compound from end of cross-level bubble (14) and loosen setscrew (11).
- f. Loosen ring (12), using spanner wrench.
- g. Turn eccentric (13) until cross level bubble (14) centers.

2-66. M198 HOWITZER—MAINTENANCE INSTRUCTIONS (cont)

SYNCHRONIZATION (cont)

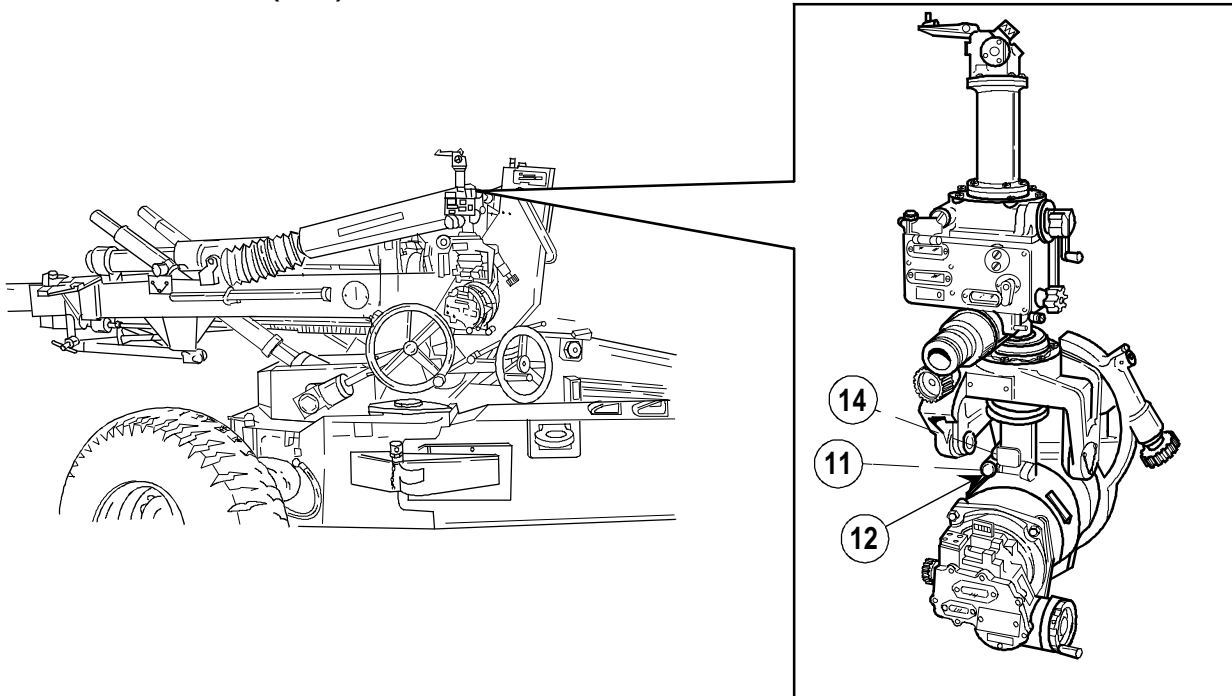

- h. Tighten ring (12).
- i. Ensure cross level bubble (14) remained centered.
- j. Apply sealing compound and tighten setscrew (11).

NOTE

If removal of elevation deviation (steps c thru j) was required, perform boresight procedure to ensure boresighting remained accurate.

- k. Repeat step b to ensure tolerances are met. If any of the tolerances cannot be met, remove the defective fire control equipment and send to general support instrument shop for repair.

Section VIII. PREPARATION FOR STORAGE OR SHIPMENT

2-67. PREPARATION FOR STORAGE OR SHIPMENT

Refer to TM 9-1025-211-20&P for preparation for storage or shipment requirements.

Section IX. PRE-EMBARKATION INSPECTION OF MATERIAL IN UNITS ALERTED FOR OVERSEAS MOVEMENT

2-68. PRE-EMBARKATION INSPECTION

See TB 9-1000-247-34, Standards for Oversea Shipment of Domestic Issue of Small Arms, Aircraft Armament, Towed Howitzers, Mortars, Recoilless Rifles, Rocket Launchers and Associated Fire Control Equipment.

CHAPTER 3 GENERAL SUPPORT MAINTENANCE INSTRUCTIONS

CHAPTER INDEX

Section	Page
I. Troubleshooting	3-1
II. General Support Maintenance Procedures	3-3

Section I. TROUBLESHOOTING

Section Index

Paragraph	Page
3-1. Troubleshooting Information.....	3-1

3-1. TROUBLESHOOTING INFORMATION

- a. Use information in this section with troubleshooting in chapter 2. It provides instructions where the direct support maintenance manual refers to general support maintenance for corrective action.
- b. Use the symptom index as a quick guide to troubleshooting. Common malfunctions are listed in alphabetical order under each major assembly, which appear in MAC order, with a page number reference to the troubleshooting table where a test or inspection and corrective action are provided.
- c. The table lists the common malfunctions which you may find during the operation or maintenance of the M198 howitzer or its components. Perform the tests/inspections and corrective actions in the order listed.
- d. This manual cannot list all malfunctions that may occur, nor all tests or inspections and corrective actions. If a malfunction is not listed or is not corrected by listed corrective actions, notify your supervisor.

SYMPTOM INDEX

	Troubleshooting Procedure (Page)
ADAPTER AND ADAPTER ASSEMBLY	
Adapter assembly does not accept M172 telescope and quadrant mount	3-2
Adapter does not accept M171 telescope and quadrant mount	3-2
M137 panoramic telescope is not in tolerance with M139 alinement device	3-2

3-1. TROUBLESHOOTING INFORMATION (cont)

Table 3-1. General Support Troubleshooting

MALFUNCTION	TEST OR INSPECTION	CORRECTIVE ACTION
<hr/>		
ADAPTER AND ADAPTER ASSEMBLY		
1.	ADAPTER DOES NOT ACCEPT M171 TELESCOPE AND QUADRANT MOUNT.	
	Check for mutilation or distortion.	
		Replace adapter (p 3-3).
2.	ADAPTER ASSEMBLY DOES NOT ACCEPT M172 TELESCOPE AND QUADRANT MOUNT.	
	Check for mutilation or distortion of adapter assembly.	
		Replace adapter assembly (p 3-3).
3.	M137 PANORAMIC TELESCOPE IS NOT IN TOLERANCE WITH M139 ALINEMENT DEVICE.	
	Step 1. Check for defective M139 alinement device by performing M139 alinement device comparison test (TM 9-1025-211-10).	
		Replace M139 alinement device (TM 9-1025-211-10) if defective.
	Step 2. Check for missing or improperly installed shims between adapter and left trunnion.	
		Remove, reinstall, and shim adapter (p 3-3).
	Step 3. Check for mutilation or distortion of adapter assembly.	
		Replace adapter assembly (p 3-3).
	Step 4. Check for missing or improperly installed shims between adapter assembly and right trunnion.	
		Remove, reinstall, and shim adapter assembly (p 3-3).

3-2. ADAPTER, ADAPTER ASSEMBLY, SUPPORT STUD, AND PIN ASSEMBLY— MAINTENANCE INSTRUCTIONS (cont)

REMOVAL

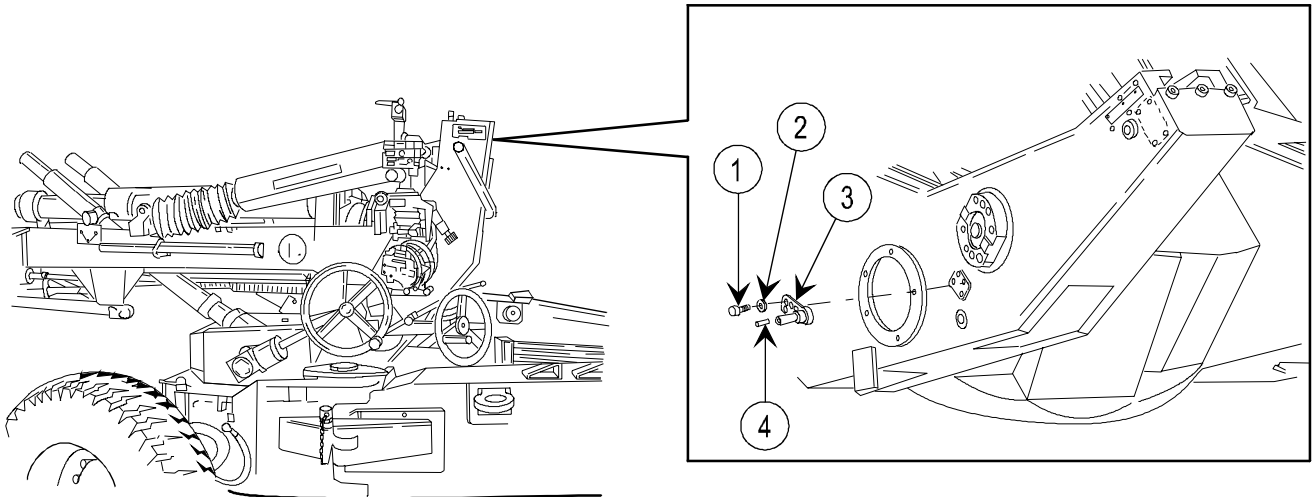

NOTE

Do not remove support stud (steps 1 thru 3) unless necessary to replace authorized parts.

- 1 Remove lock wire, four capscrews (1), and four lockwashers (2) from support stud (3).
- 2 Drive two straight pins (4) in through support stud (3).
- 3 Remove support stud (3).

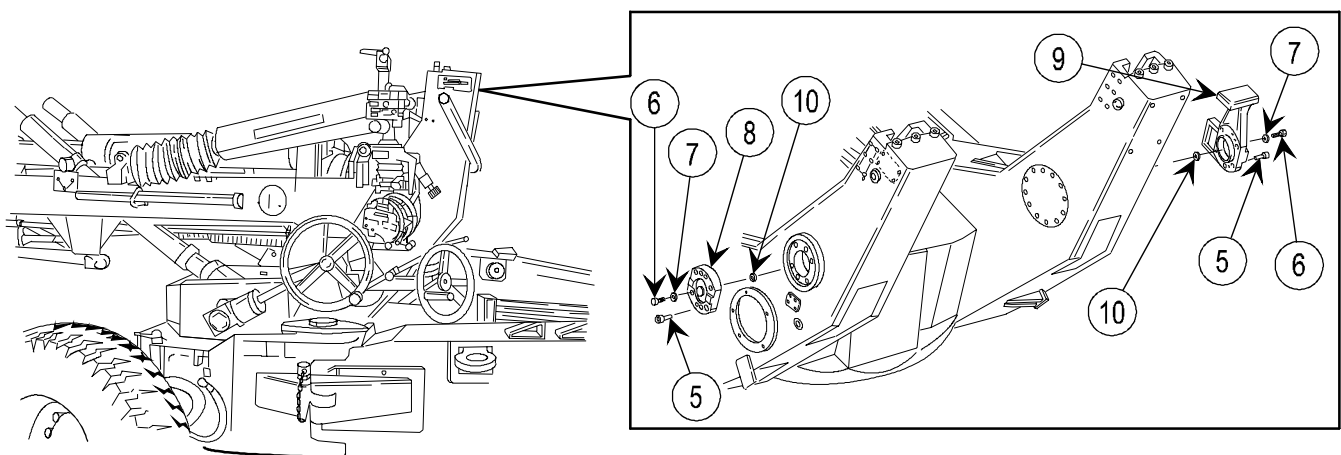

- 4 Remove four pin assemblies (5).
- 5 Remove four socket head screws (6), four lockwashers (7), adapter (8), adapter assembly (9), and shims (10).

INSPECTION/REPAIR

- 1 Check for broken, damaged, or missing parts.
- 2 Repair is by replacement of authorized parts (TM 9-1025-211-34P).

INSTALLATION AND SHIMMING

NOTE

1. Prior to installation, make sure that all mounting surfaces are clean and free of paint and burrs. Wipe with wiping rag.
2. Use the following procedures to minimize backlash:
 - a. **Knobs.** To eliminate backlash, make sure the final movement of all knobs is in a clockwise direction. The last motion of the knob shall be clockwise. This principle applies to all fire control instruments, including the gunner's quadrant.
 - b. **Traverse.** The last motion of the traversing handwheel should cause the weapon or sighting device to approach the aiming point from left to right.
 - c. **Elevation.** The last motion of the elevating handwheel should be in the direction that raises the muzzle.
3. Replace pin assembly if loose and will not tighten enough to ensure positive alinement of adapter.

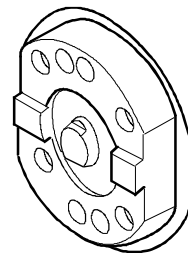

ADAPTER

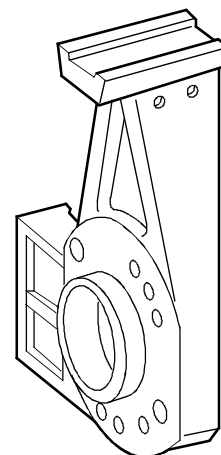

ADAPTER ASSEMBLY

NOTE

Procedures 1 thru 11 apply to both the adapter (left trunnion) and the adapter assembly (right trunnion). When procedures are identical, only the adapter is illustrated and covered in the text.

3-2. ADAPTER, ADAPTER ASSEMBLY, SUPPORT STUD, AND PIN ASSEMBLY— MAINTENANCE INSTRUCTIONS (cont)

INSTALLATION AND SHIMMING (cont)

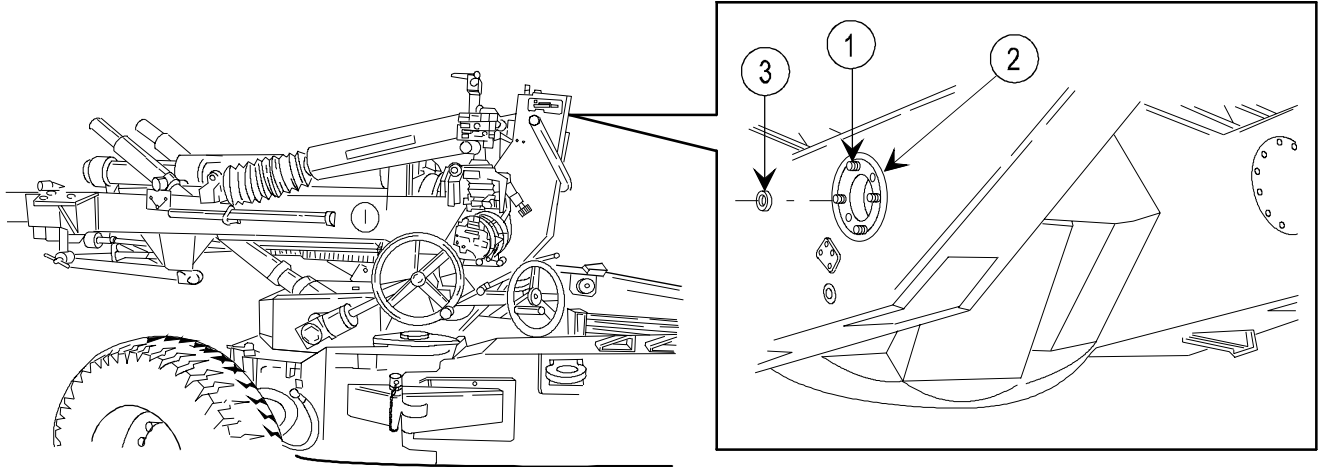

- 1 Screw four alignment studs (1) into trunnion (2).
- 2 Place one 0.004 in. (0.010 cm) shim (3) on each alignment stud (1).
- 3 Install adapter (4) on trunnions over alignment studs (1).
- 4 Install two socket head screws (5) and two lockwashers (6) through adapter (4) into trunnion (2), and tighten screws enough to prevent loss of shims.
- 5 Remove alignment studs (1).

NOTE

M1A1/M1A2 gunner's quadrant must be set to zero mils with correction added for steps 6 and 9.

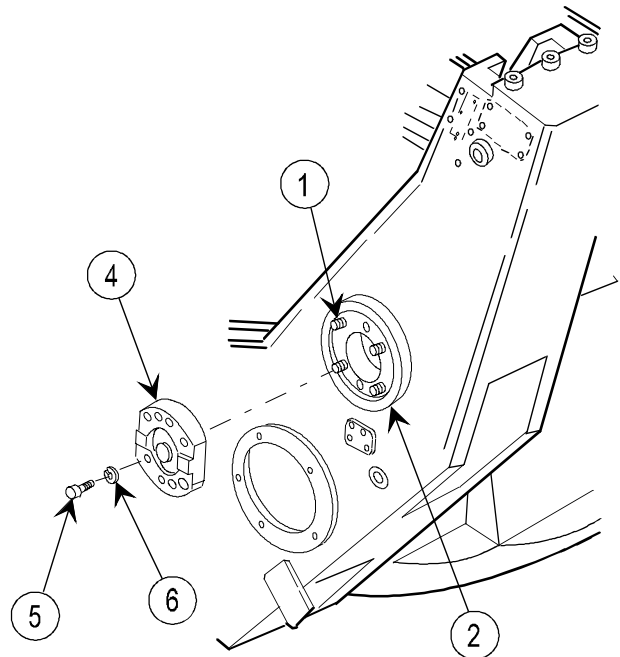

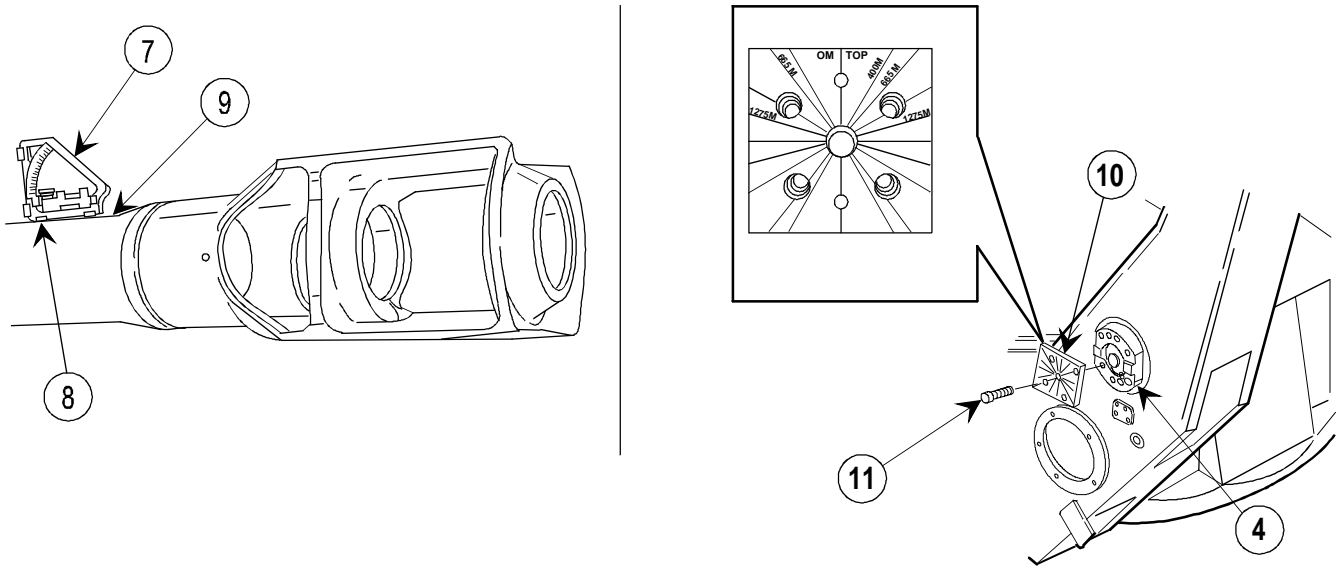

- 6 Place M1A1/M1A2 gunner's fire control quadrant (7) on cannon leveling pads (8) and level cannon tube (9) to zero mils (TM 9-1025-211-10).

NOTE

Alinement fixture (10) and screws (11) are part of the adapter kit (12000682-2).

- 7 Place alinement fixture (10) over adapter (4).

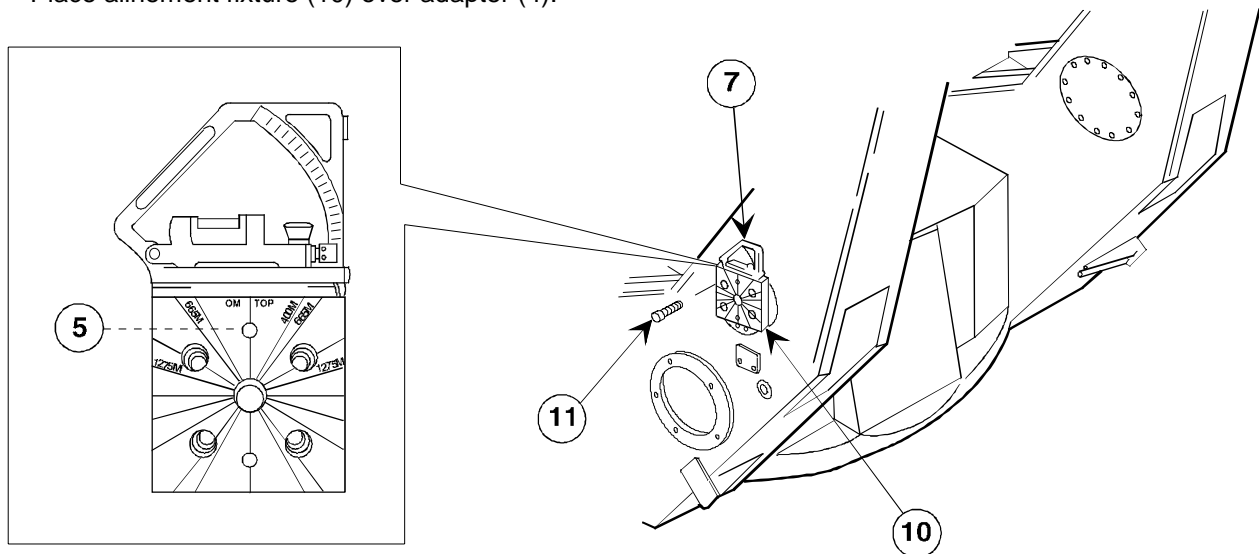

- 8 Install four screws (11), but do not tighten.
- 9 Place M1A1/M1A2 gunner's fire control quadrant (7) on alinement fixture (10), and tap alinement fixture with plastic hammer to level alinement fixture with cannon tube.
- 10 Torque two socket head screws (5) to 80-85 in.-lb (9 N-m).
- 11 Torque four screws (11) to 85-90 ft-lb (115 N-m).

3-2. ADAPTER, ADAPTER ASSEMBLY, SUPPORT STUD, AND PIN ASSEMBLY— MAINTENANCE INSTRUCTIONS (cont)

INSTALLATION AND SHIMMING (cont)

NOTE

The adapter assembly shimming procedures are different from the adapter shimming procedures. This is to align the M139 alinement device to the M137 panoramic telescope. Procedures 12 thru 20 are for shimming the adapter between 0 and 1275 mils elevation to ± 0.2 mils. Procedures 21 thru 28 are for shimming the alinement device and adapter assembly to tolerances of ± 0.2 mils total from 0 to 400 mils elevation and ± 0.6 mils total from 401 to 1275 mils elevation.

Howitzer elevation will be set by the M1A1/M1A2 gunner's fire control quadrant set to the elevation required, then placed on the top surface of the alinement fixture. The line of fire arrow on the M1A1/M1A2 gunner's quadrant should point toward the muzzle.

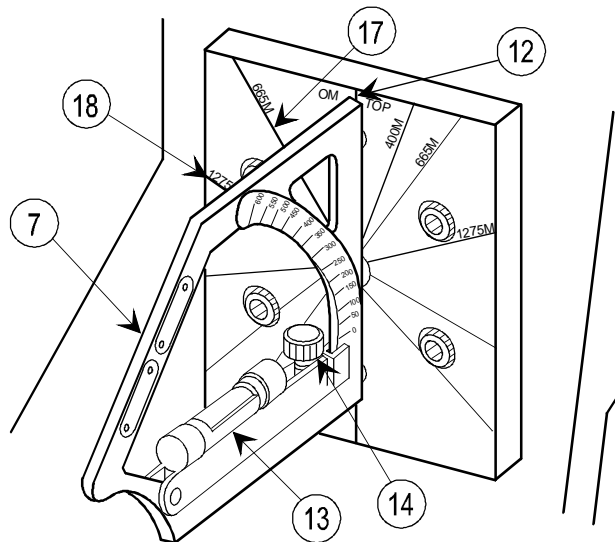

- 12 At zero-mil elevation, place M1A1/M1A2 gunner's fire control quadrant (7) (zero mil entered) on alinement fixture scribe line (12), level bubble (13) using micrometer knob (14), and record reading.
- 13 At 665-mil elevation, place M1A1/M1A2 gunner's fire control quadrant (7) on scribe line (17), level bubble (13), and record reading.
- 14 At 1275-mil elevation, place M1A1/M1A2 gunner's fire control quadrant (7) on scribe line (18), level bubble (13), and record reading.
- 15 If adapter is not vertical to ± 0.2 mil total at above elevations, it must be shimmed until tolerance is obtained.

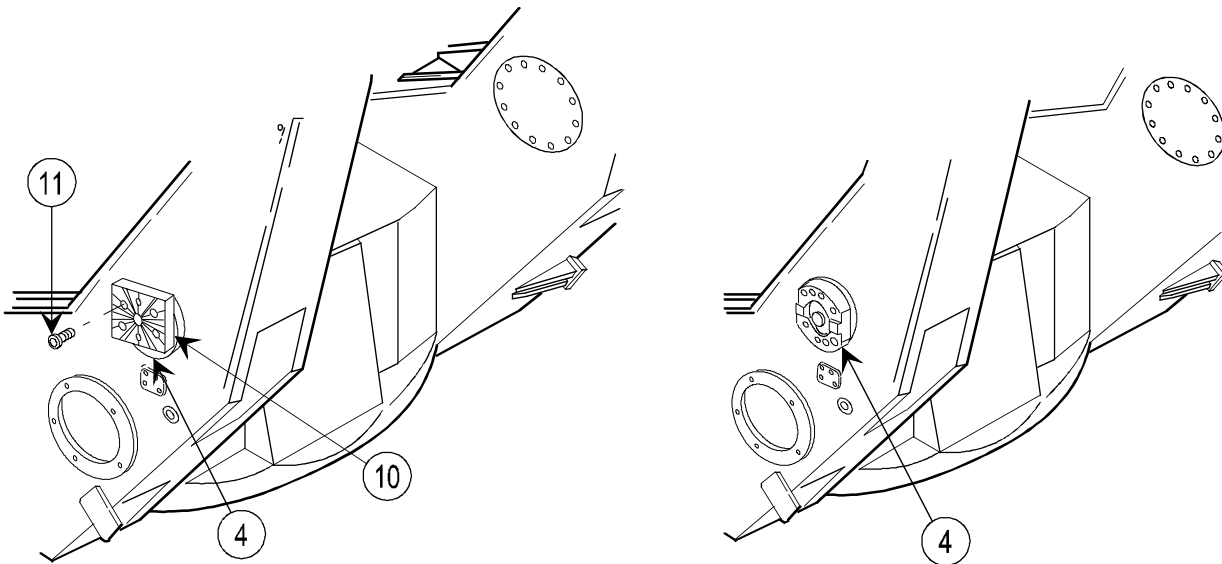

- 16 If shimming is required, relevel adapter (4) with cannon tube when installing and retorquing screws.
- 17 Remove four screws (11).
- 18 Remove alignment fixture (10) from adapter (4).

NOTE

If the adapter or adapter assembly has been moved from its original position, the two dowel pin holes must be reamed oversize in the new position. Measure the diameter of the original split sleeve.

If a new adapter (4) is being installed, note the two dowel pin holes are $27/64$ in. (1.07 cm) diameter pilot holes only. Use the $7/16$ in. diameter drill bushing and drill to enlarge the holes to the first dowel sleeve size. Continue to ream the plate and trunnion hole in $1/64$ in. (0.04 cm) increments to accommodate the oversize sleeve.

If the original adapter is being used, the holes in the plate and trunnions may be reamed in $1/64$ in. (0.04 cm) increments to accommodate the desired oversize dowel sleeve.

Before final reaming of split pin holes, place M1A1/M1A2 gunner's fire control quadrant on top surface of drill fixture and check that the adapter key remains parallel to centerline of the gun tube.

- 19 Install the M171 mount, M17 quadrant, and M137 panoramic telescope; boresight using the test target method in section VII.

3-2. ADAPTER, ADAPTER ASSEMBLY, SUPPORT STUD, AND PIN ASSEMBLY— MAINTENANCE INSTRUCTIONS (cont)

INSTALLATION AND SHIMMING (cont)

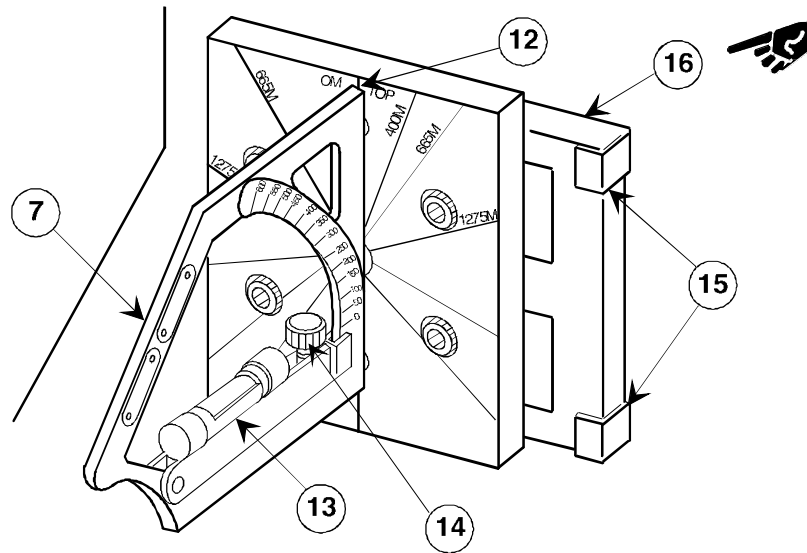

NOTE

Procedures 20 thru 27 apply to the direct firing side and are only to be performed after the indirect side has been boresighted.

- 20 At zero-mil elevation, place M1A1/M1A2 gunner's fire control quadrant (7) (zero mil entered) on alinement fixture scribe line (12), level bubble (13) using micrometer knob (14), and record reading.

NOTE

If the reading obtained with the M1A1/M1A2 gunner's fire control quadrant (7) on alinement fixture scribe line (12) is not within ± 0.1 mil of the reading obtained with the quadrant on the cross level pads (15) of the adapter assembly, the adapter assembly (16) is distorted and must be replaced.

- 20.1 Place M1A1/M1A2 gunner's fire control quadrant (7) on cross-level pads (15). Level bubble (13) using micrometer knob (14), and record reading.
- 20.2 Compare readings from steps 20 and 20.1. Reading should not differ more than 0.1 mil. If difference is greater, adapter assembly is distorted and must be replaced.
- 21 Install the M139 alinement device onto the dovetail of the adapter assembly.
- 22 Set the M137 panoramic telescope to 4800 mils azimuth and 0000 mils deflection.
- 23 Adjust the elevation knob on the head assembly of the M137 panoramic telescope to its mid position.
- 24 Aline the reticle in the M137 panoramic telescope with the reticle in the M139 alinement device to within ± 0.025 mil.
- 25 If adjustment in elevation is required, turn the elevation knob on the M137 panoramic telescope head assembly to aline the reticle vertically.

- 26** If the M139 alinement device error is greater than ± 0.025 mil, adjustment to the adapter assembly is required. Reshim the adapter assembly side only. Generally, if the reading is less than 4800 mils, the front two holes should be shimmed. If the reading is greater than 4800 mils, the rear two holes should be shimmed.
- 27** If adapter assembly is not vertical to ± 0.2 mil total at elevations of 0 to 400 mils and ± 0.6 mil total at elevations of 401 to 1275 mils, it must be shimmed until tolerance is obtained. The tolerance of ± 0.025 mil for alinement of the M139 alinement device to the M137 panoramic telescope must also be maintained.

WARNING

Wear safety glasses for drilling operations.

NOTE

If the adapter or adapter assembly has been moved from its original position, the two dowel pin holes must be reamed oversize in the new position. Measure the diameter of the original split sleeve.

If the new adapter (4) is being installed, note the two dowel pin holes are 27/64 in. (1.07 cm) diameter pilot holes only. Use the 7/16 in. diameter drill bushing and drill to enlarge the holes to the first dowel sleeve size. Continue to ream the plate and trunnion hole in 1/64 in. (0.04 cm) increments to accommodate the desired oversize sleeve.

If the original adapter is being used, the holes in the plate and trunnions may be reamed in 1/64 in. (0.04 cm) increments to accommodate the desired oversize dowel sleeve.

Before final reaming of split pin holes, place M1A1/M1A2 gunner's fire control quadrant on top surface of drill fixture and check that the adapter key remains parallel to centerline of the gun tube.

**3-2. ADAPTER, ADAPTER ASSEMBLY, SUPPORT STUD, AND PIN ASSEMBLY—
MAINTENANCE INSTRUCTIONS (cont)**

INSTALLATION AND SHIMMING (cont)

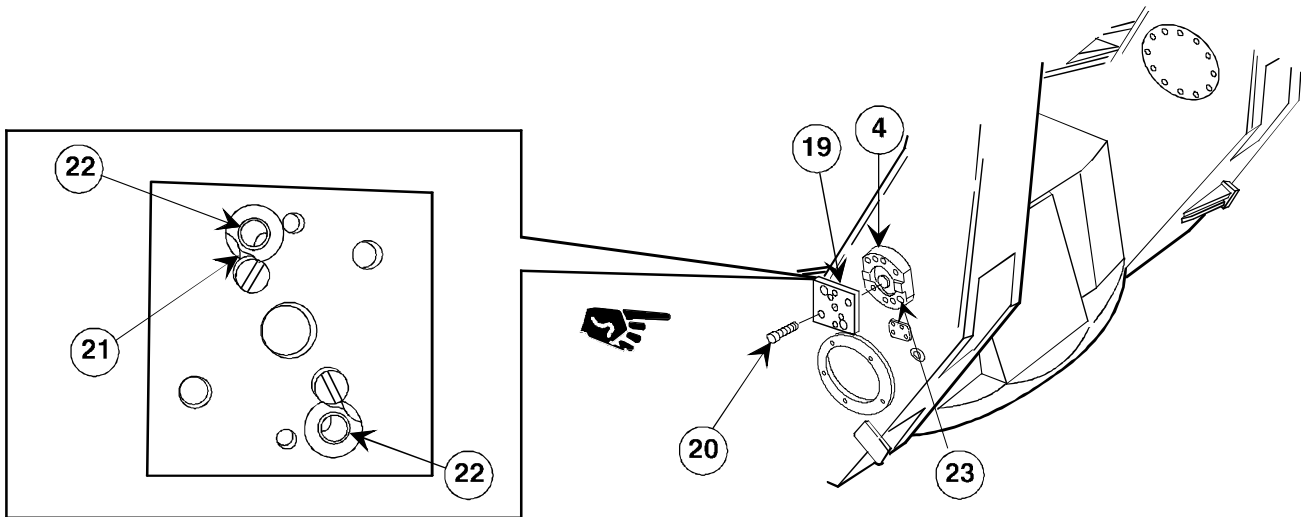

- 28 Install trunnion adapter fixture (19) on adapter (4) using two screws (20), and torque to 80-85 ft-lb (115 N-m).

NOTE

If the dowel pin holes must be reamed for the next larger size split sleeve, perform steps 29 thru 34.

- 29 Install required drill bushing (21), lock into place, and drill or ream dowel pin holes (22) to accommodate determined oversize split sleeve (see NOTE before step 28).

- 30 Remove two screws (20).

- 31 Remove trunnion adapter assembly fixture (19) from adapter (4).

- 32 Remove chips or shavings from split sleeve holes (23) .

- 33 Sleeve bushings (24) are supplied in three different sizes. Install sleeve bushing (24) and nut (25) on pin (26).

- 34 Install pin assembly (27) into reamed holes and alternately tighten in increments of 15-20 in.-lb (2.25 N-m) each up to 75-80 in.-lb (9 N-m).

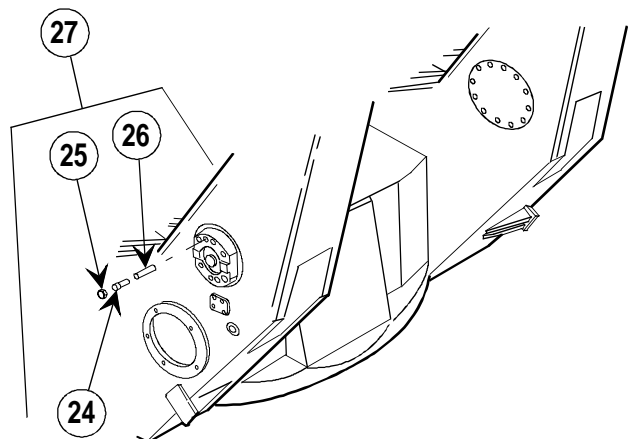

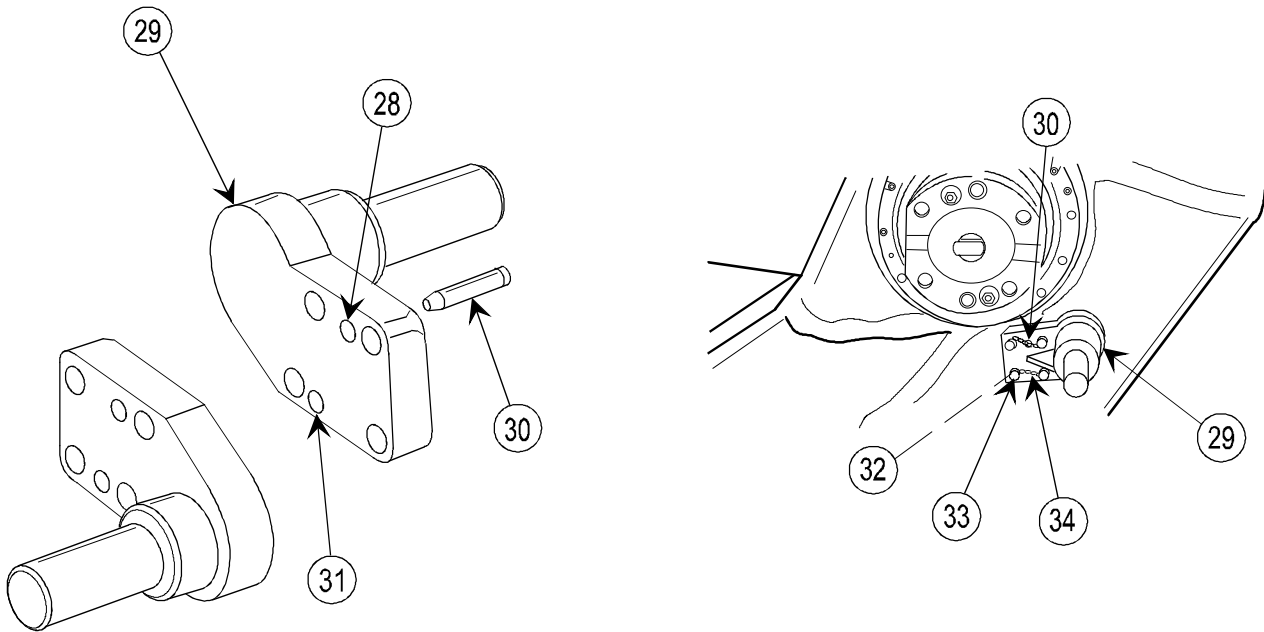

WARNING

Wear safety glasses for drilling operations.

- 35 Drill hole (28) to 0.310 + 0.002-in. (7.880 + 0.040-mm) diameter in new support stud (29).
- 36 Install straight pin (30) through hole (28) in new support stud (29) and one of the two 0.310-in. (7.880-mm) diameter holes in the old support stud.
- 37 Aline hole (31) with second 0.310-in. (7.880-mm) diameter hole in the old support stud as closely as possible.
- 38 Using old support stud as a guide, drill hole (31) to 0.310 +0.002-in. (7.880 +0.040-mm) diameter.
- 39 Remove straight pin (30) from old and new support studs (29).
- 40 Install two new straight pins (30) in holes (28 and 31) so that they extend approximately 0.25 in. (6.40 mm) through the back side of support stud (29).
- 41 Install support stud (29), four lockwashers (32), and four capscrews (33), and torque 120 to 130 in.-lb (14 to 15 N-m).
- 42 Drive in two straight pins (30) until only the crowns extend from support stud (29) (do not drive flush). Install lock wire (34).

APPENDIX A REFERENCES

A-1. SCOPE

This appendix lists all forms, field manuals, technical manuals, technical bulletins, and miscellaneous publications referenced in this manual.

A-2. FORMS

DA Form 2028.....	Recommended Changes to Publications and Blank Forms
DA Form 2028-2.....	Recommended Changes to Equipment Technical Manuals
MCO 4855.10.....	Quality Deficiency Report
NAVMC 10772	Recommended Changes to Technical Publications
SF 368.....	Product Quality Deficiency Report

A-3. FIELD MANUALS (FM)

FM 21-11	First Aid for Soldiers
----------------	------------------------

A-4. TECHNICAL MANUALS (TM)

TM 9-237.....	Operator's Manual: Welding Theory and Application
TM 9-254.....	General Maintenance Procedures for Fire Control Materiel
TM 9-1000-202-14	Operator's, Unit, Direct Support, and General Support Maintenance Manual for Evaluation of Cannon Tubes
TM 9-1025-211-10	Operator's Manual for Howitzer, Medium, Towed: 155-mm, M198 (1025-01-026-6648)
TM 9-1025-211-20&P.....	Unit Maintenance Manual (Including Repair Parts and Special Tools List) for Howitzer, Medium, Towed: 155-mm, M198 (1025-01-026-6648)
TM 9-1025-211-34P.....	Direct Support and General Support Maintenance Repair Parts and Special Tools List (Including Depot Maintenance Repair Parts and Special Tools List) for Howitzer, Medium, Towed: 155-mm, M198 (1025-01-026-6648)
TM 9-1240-375-34	Direct Support and General Support Maintenance Manual for Quadrant, Fire Control: M17 (1290-01-037-3883); Quadrant, Fire Control: M18 (1290-01-037-7289); Mount, Telescope and Quadrant: M171 (1240-01-039-7273); Mount, Telescope and Quadrant: M172 (1240-01-037- 7290); Telescope, Panoramic: M137 (1240-01-038-0531); and Telescope, Elbow: M138 (1240-01-038-0530)

A-4. TECHNICAL MANUALS (TM) (CONT)

TM 9-1240-375-34P	Direct Support and General Support Maintenance Repair Parts and Special Tools List (Including Depot Maintenance Repair Parts and Special Tools List) for Quadrant, Fire Control: M17 (1290-01-037-3883); Quadrant, Fire Control: M18 (1290-01-037-7289); Mount, Telescope and Quadrant: M171 (1240-01-039-7273); Mount, Telescope and Quadrant: M172 (1240-01-037-7290); Telescope, Panoramic: M137 (1240-01-038-0531); and Telescope, Elbow: M138 (1240-01-038-0530)
TM 9-4933-201-15P	Operator's, Unit, Direct Support, General Support, and Depot Maintenance Repair Parts and Special Tools List for Pump Kit, Hydraulic Oil, Gun Recoil M3, 5000 psi Maximum Pressure, Double Acting Hand Pump
TM 9-4933-258-13&P.....	Operator's, Unit, and Direct Support Maintenance Manual (including Repair Parts and Special Tools List) for pullover gage kit (PN 7242997)
TM 9-6650-235-13&P.....	Operator's, Unit and Direct Support Maintenance Manual (including Repair Parts and Special Tools List) (including Depot Maintenance Repair Parts) for Borescope M3 (6650-01-063-0035)
TM 43-0139.....	Painting Instructions for Army Materiel
TM 4700-15/1	Equipment Record Procedures

A-5. TECHNICAL BULLETINS (TB)

TB 9-1000-247-34	Standards for Overseas Shipment or Domestic Issue of Small Arms, Aircraft Armament, Towed Howitzers, Mortars, Recoilless Rifles, Rocket Launchers and Associated Fire Control Equipment
TB 9-1025-211-34	Repair Welding Procedures for Howitzer, Medium, Towed: 155-mm, M198 (1025-01-026-6648)

A-6. MISCELLANEOUS PUBLICATIONS

CTA 8-100.....	Army Medical Department Expendable/Durable Items
CTA 50-970.....	Expendable Items (Except Medical, Class V, Repair Parts, and Heraldic Items)
DA PAM 738-750	The Army Maintenance Management System (TAMMS)

APPENDIX B EXPENDABLE/DURABLE SUPPLIES AND MATERIALS LIST

Section I. INTRODUCTION

B-1. SCOPE

This appendix lists expendable supplies and materials you will need to operate and maintain the M198 howitzer. This listing is for informational purposes only and is not authority to requisition the listed items. These items are authorized to you by CTA 50-970, Expendable/Durable items (Except Medical, Class V, Repair Parts, and Heraldic items), or CTA 8-100, Army Medical Department Expendable/Durable Items.

B-2. EXPLANATION OF COLUMNS

- a. Column (1)—Item Number.** This number is assigned to the entry in the listing and is referenced in the narrative instructions to identify the material (e.g., "Use cleaning compound (item 5, appx B)."
- b. Column (2)—Level.** This column identifies the lowest level of maintenance that requires the listed item.
 - F—Direct support maintenance
 - H—General support maintenance
- c. Column (3)—National Stock Number.** This is the National stock number assigned to the item; use it to request or requisition the item.
- d. Column (4)—Description.** Indicates the Federal item name and, if required, a description to identify the item. The last line for each item indicates the Commercial and Government Entity Code (CAGEC) in parenthesis followed by the part number.
- e. Column (5)—Unit of Measure (U/M).** Indicates the measure used in performing the actual maintenance function. This measure is expressed by a two-character alphabetical abbreviation (e.g., ea, in., pr). If the unit of measure differs from the unit of issue, requisition the lowest unit of issue that will satisfy your requirements.

Section II. EXPENDABLE/DURABLE SUPPLIES AND MATERIALS LIST

(1) ITEM NUMBER	(2) LEVEL	(3) NATIONAL STOCK NUMBER	(4) DESCRIPTION	(5) U/M
1	F	8040-00-515-2250	ADHESIVE (04963) EC871	QT
2	F	8040-00-849-5195	ADHESIVE, EPOXY (81349) MIL-A-81236	KT
3	F	8040-00-390-7959	ADHESIVE, RUBBER, SYNTHETIC, liquid, 1-qt (0.946-l) can (76381) EC847	QT

Section II. EXPENDABLE/DURABLE SUPPLIES AND MATERIALS LIST (cont)

(1) ITEM NUMBER	(2) LEVEL	(3) NATIONAL STOCK NUMBER	(4) DESCRIPTION	(5) U/M
4	F	8030-00-597-5367	ANTISEIZE COMPOUND, (81349) MIL-A-907 2.5-lb (1.13-kg) can	OZ
4.1	C	8105-00-269-4662	BAG, PLASTIC: waterproof and greaseproof (81349) MIL-B-117D 20 X 25, std pkg 100	EA
5	F	9150-01-059-2586 9150-01-102-9455	BRAKE FLUID, SILICONE, AUTOMOTIVE: (BFS) (81348) MIL-B-46176 1-gal. (3.79-l) metal container 1-gal. (3.79-l) plastic container	CN CN
6	F	7510-00-223-6701	CHALK, MARKING (81348) SS-C-255 Gross (144)	EA
6.1	O	9150-01-054-6453 9150-01-053-6688	CLEANER, LUBRICANT AND PRESERVATIVE (81349) MIL-L-63640 1 pt (0.47-l) btl w/trigger sprayer 1 gal. (3.79-l) bottle	PT GL
7	F	6850-00-597-9765	CLEANING COMPOUND: liquid form (solvent) (80063) 6G236-6	GL
8	F	5350-00-268-3116 5350-00-221-0872	CLOTH, ABRASIVE: crocus (81348) P-C 458 2 wide x 50 yd (45.72 m) 9 x 11 sh, 50 sh sleeves	EA EA
9	C	1025-01-311-3770	CLOTH, CLEANING, SLEEVE: (27412) 155/203-40	BX
10	F	4020-00-240-2154	CORD, FIBROUS, type 1, (81349) MILC5040 500-yd (457.2-m) spool	SL
11	F	9150-00-944-8953 9150-00-181-7724 9150-00-145-0268	GREASE, AIRCRAFT: general purpose wide temperature range (WTR) (81349) MIL-G-81322 1 lb (0.45 kg) 8 oz (226.8 g) 5 lb (2.27 kg)	LB TU LB

(1) ITEM NUMBER	(2) LEVEL	(3) NATIONAL STOCK NUMBER	(4) DESCRIPTION	(5) U/M
12			DELETED	
13	F	9150-00-223-4004	GREASE, MOLYBDENUM DISULFIDE (GMD) (81349) MIL-G-21164 6.5-lb (2.95-kg) can	LB
14	F	9150-00-935-9807 9150-00-935-9808	HYDRAULIC FLUID, PETROLEUM BASE PRESERVATIVE: (OHT) (81348) MIL-PRF-6083F 1-qt (0.95-l) container 1-gal. (3.79-l) container	QT GL
14.1	O	9150-00-142-9361	LUBRICANT, SOLID FILM, AIR-CURED, CORROSION-INHIBITING (81349) MIL-L-46147 can	GL
15	F	9150-00-231-6689 9150-00-231-9062	LUBRICATING OIL, GENERAL PURPOSE: special preservative (PL-S) (81348) VV-L-800 1 qt (0.95 l) 1 gal. (18.93 l)	QT GL
16	C	8010-01-141-2419	PAINT, BLACK (CARC) (81349) MIL-C-46168	KT
17	C	8010-01-160-6744	PAINT, BROWN (CARC) (81349) MIL-C-46168	KT
18	C	8010-01-160-6741	PAINT, GREEN (CARC) (81349) MIL-C-46168	KT
19	F	8010-00-935-7080	PRIMER COATING (81349) MIL-P-23377	KT
20	F	8010-00-899-0931	PRIMER COATING (81348) TT-P-1757 1-qt (0.946-l) can	OZ
21	C	8010-01-193-0516	PRIMER COATING (CARC) (81349) MIL-P-53022	KT
22	F	7920-00-205-1711	RAG, WIPING: cotton (81348) DDD-R-30 50 lb (22.60 kg)	BE
23	F	8010-00-943-7128	REMOVER, PAINT (81348) TT-R-248	GL

Section II. EXPENDABLE/DURABLE SUPPLIES AND MATERIALS LIST (cont)

(1) ITEM NUMBER	(2) LEVEL	(3) NATIONAL STOCK NUMBER	(4) DESCRIPTION	(5) U/M
24	C	8010-00-181-7568	REMOVER, PAINT (CARC) (61102) TURCO5469	GL
25	F	8030-00-081-2326 8030-00-081-2335 8030-00-081-2330 8030-00-963-0930	SEALING COMPOUND, liquid (81349) MIL-S-22473 10-cc bottle, grade H 10-cc plastic squeeze btl, grade B 50-cc bottle, grade CV surface primer, grade T, form R	CC CC CC OZ
26	F	8030-00-753-4596	SEALING COMPOUND (81343) AMS-S-8802 CLA-1/2	KT
27	F	8030-00-181-7884	SEALING COMPOUND, rubber, synthetic, (81349) MIL-S-8516 3.5-oz (0.10-l) cartridge	OZ
28	F	8030-00-252-3391	SEALING COMPOUND, resin paste (81349) MIL-S-45180 11-oz (312-g) tube	OZ
28.1	F	8030-01-158-6070	SEALING COMPOUND, liquid (81349) MIL-S-46163 Type 1, Grade K, Threadlocker, 50cc squeeze bottle	CC
29	F	6850-00-295-7685	SILICONE COMPOUND, w/corrosion inhibitor (81349) MIL-S-8650 10-lb (4.54-kg) can	LB
30	F	8520-00-228-0598	SOAP, TOILET: liquid (81348) P-S-624 6 gal. (22.71 l)	GL
31	F	3439-00-824-9856	SOLDER, TIN ALLOY (81348) QQ-S-571 1-lb (0.45-kg) spool	LB
32	F	8030-00-889-3534	TAPE, ANTISEIZING (81349) MIL-T-27730	EA
32.1	F		TAPE, ELECTRICAL 88 - Super 3/4 in. (1.9 cm) x 66 ft (20 m)	EA

(1) ITEM NUMBER	(2) LEVEL	(3) NATIONAL STOCK NUMBER	(4) DESCRIPTION	(5) U/M
33	F	9505-00-592-4690	WIRE, NONELECTRICAL, carbon steel, zinc-coated (96906) MS20995-F32 0.032-in. (0.085-cm) dia	LB
34	F	9505-00-248-9849	WIRE, NONELECTRICAL, carbon steel, zinc-coated (96906) MS20995-F41 0.041-in. (0.104-cm) dia	EA
35	F	9505-00-248-9850	WIRE, NONELECTRICAL, carbon steel, zinc-coated (96906) MS20995-F47 0.047-in. (0.115-cm) dia	IN.
36	F	9505-00-248-9842	WIRE, NONELECTRICAL, carbon steel, zinc-coated (96906) QQW461 0.091-in. (0.231-cm) dia	LB
37	F	9505-00-221-2650	WIRE, NONELECTRICAL, corrosion-resistant steel (96906) MS20995-C20 0.020-in. (0.051-cm) dia	IN.
38	F	9505-00-293-4208	WIRE, NONELECTRICAL, corrosion-resistant steel (96906) MS20995-C32 0.032-in. (0.082-cm) dia	LB
39	F	9505-00-603-4120	WIRE, NONELECTRICAL, corrosion-resistant steel (96906) MS20995-C41-6 0.041-in. (0.104-cm) dia	EA
40	F	9505-00-603-4122	WIRE, NONELECTRICAL, corrosion-resistant steel (96906) MS20995-C47 0.047-in. (0.115-cm) dia	LB

APPENDIX C ILLUSTRATED LIST OF MANUFACTURED ITEMS

C-1. INTRODUCTION

a. This appendix includes complete instructions for making items authorized to be manufactured or fabricated at direct support maintenance.

b. A part number index in alphanumeric order is provided for cross-referencing the part number of the item to be manufactured to the figure which covers fabrication criteria.

c. All bulk materials needed for manufacture of an item are listed by part number or specification number in a tabular list on the illustration.

C-2. MANUFACTURED ITEMS PART NUMBER INDEX

Nomenclature	Figure Number
Preformed Packing Tool (Recoil)	C-1
Tubular Spanner Wrench (Ram Pump)	C-2
Trail and Bottom Carriage Bushing Puller, Final Assembly	C-3
Travel Lock Assembly, Air Lift.....	C-9

C-3. MANUFACTURED ITEMS ILLUSTRATIONS

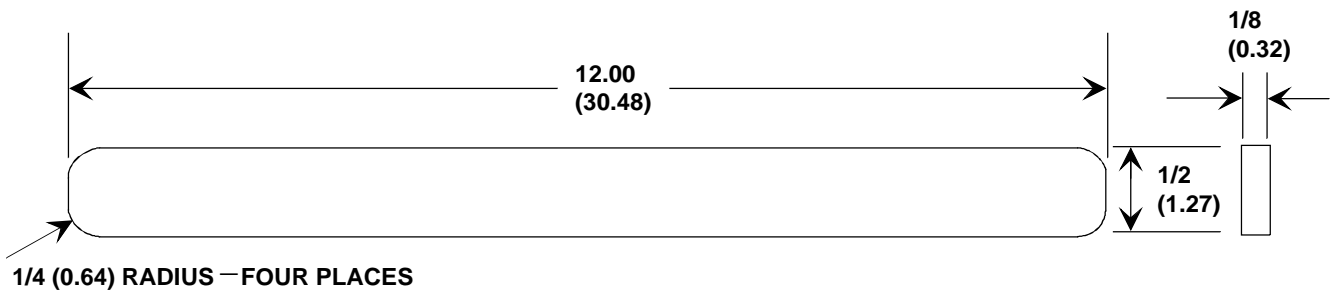

NOTES:

1. FABRICATE FROM NSN 9535-00-086-9457.
2. ALL TOLERANCES ARE ± 0.020 INCH (0.508 CM).
3. ALL DIMENSIONS SHOWN ARE IN INCHES WITH METRIC CONVERSION TO CENTIMETERS IN PARENTHESES.

Figure C-1. Preformed Packing Tool (Recoil), AL Alloy Alclad, Metal Sheet, QQ-A-250/3.

C-3. MANUFACTURED ITEMS ILLUSTRATIONS (cont)

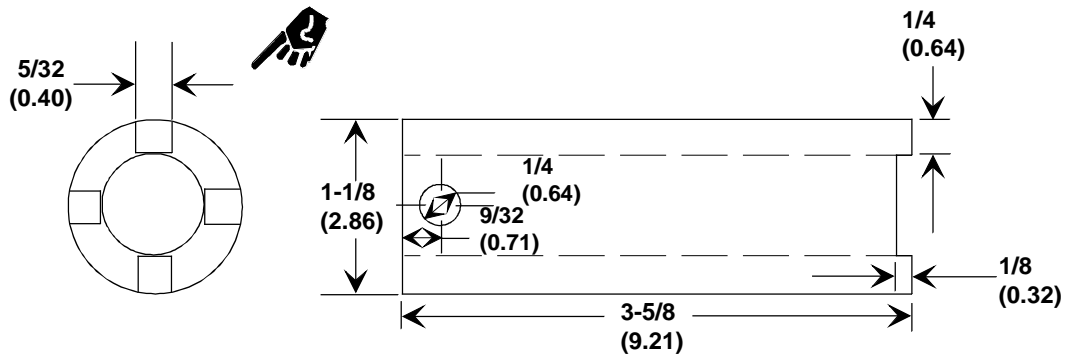

NOTES:

1. FABRICATE FROM NSN 9510-00-189-0586.
2. ALL DIMENSIONS SHOWN ARE IN INCHES WITH CONVERSION TO CENTIMETERS IN PARENTHESES.

Figure C-2. Tubular Spanner Wrench (Ram Pump), MIL-T-7081.

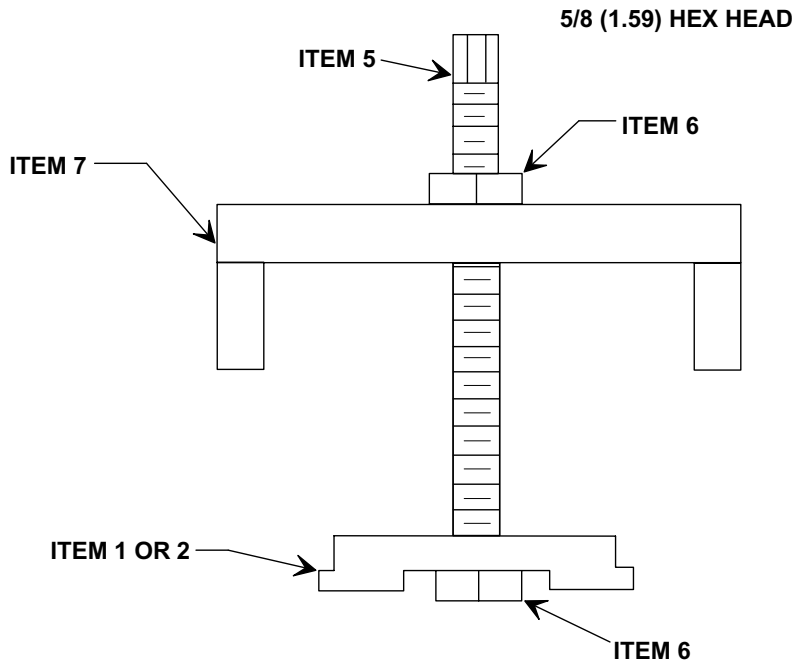

NOTES:

1. ITEM 6 IS NUT, PLAIN, HEXAGON (TWO EA) NSN 5310-00-840-5873.
2. ASSEMBLE PARTS AS SHOWN.
3. ALL DIMENSIONS SHOWN ARE IN INCHES WITH CONVERSION TO CENTIMETERS IN PARENTHESES.

Figure C-3. Trail and Bottom Carriage Bushing Puller, Final Assembly.

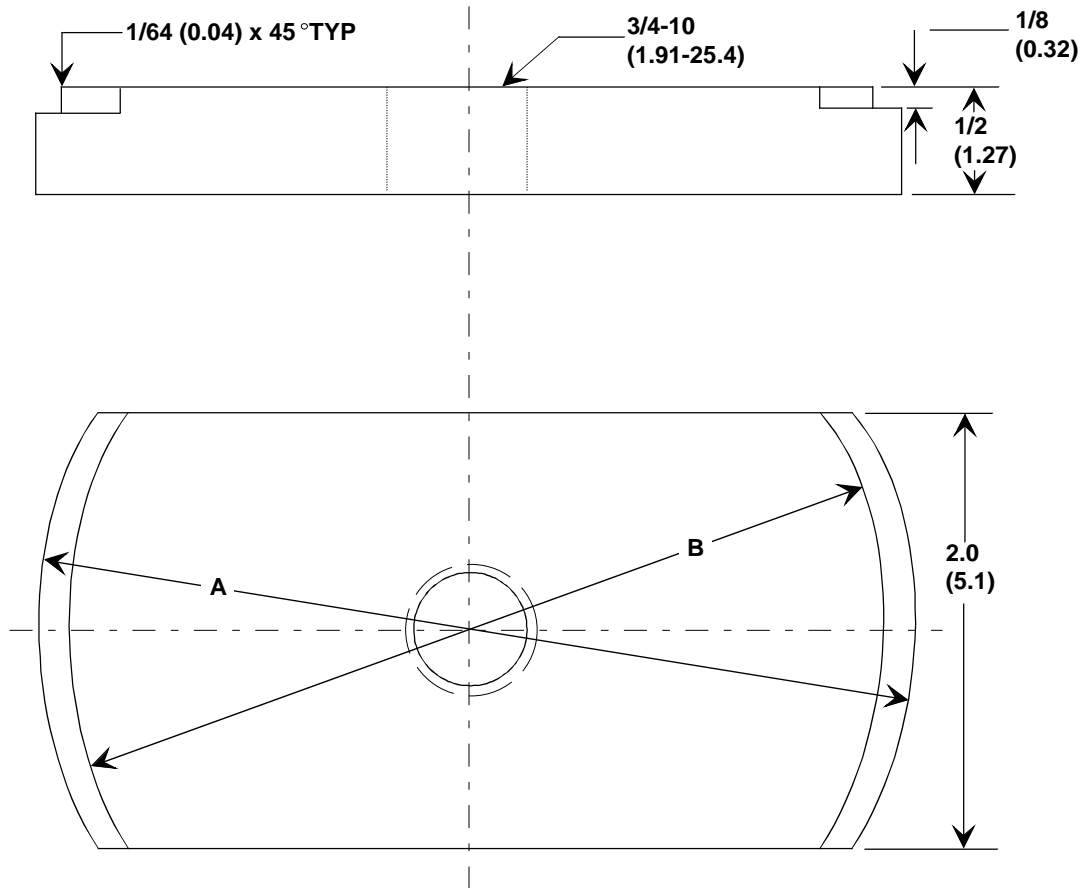

NOTES:

1. FABRICATE FROM NSN 9510-00-189-1619.
2. #1 PLATE (TRAIL BOTTOM BUSHING) — DIA A = 3.984 IN.-0.005 IN. (10.119 CM-0.013 CM)
— DIA B = 3.484 IN.-0.005 IN. (8.849 CM-0.013 CM)
3. #2 PLATE (TRAIL TOP BUSHING) — DIA A = 4.484 IN.-0.005 IN. (11.389 CM-0.013 CM)
— DIA B = 3.984 IN.-0.005 IN. (10.119 CM-0.013 CM)
4. #3 PLATE (BOTTOM BUSHING FOR BOTTOM CARRIAGE) — DIA A = 3.984 IN.-0.005 IN. (10.119 CM-0.013 CM)
— DIA B = 3.861 IN.-0.005 IN. (9.807 CM-0.013 CM)
5. #4 PLATE (TOP BUSHING FOR BOTTOM CARRIAGE) — DIA A = 4.361 IN.-0.005 IN. (11.077 CM-0.013 CM)
— DIA B = 3.984 IN.-0.005 IN. (10.119 CM-0.013 CM)
6. ALL DIMENSIONS SHOWN ARE IN INCHES WITH CONVERSION TO CENTIMETERS IN PARENTHESES.
7. FOR FINAL ASSEMBLY OF BUSHING PULLER, REFER TO FIGURE C-3.

Figure C-4. Trail and Bottom Carriage Bushing Puller, Items 1 and 2.

C-3. MANUFACTURED ITEMS ILLUSTRATIONS (cont)

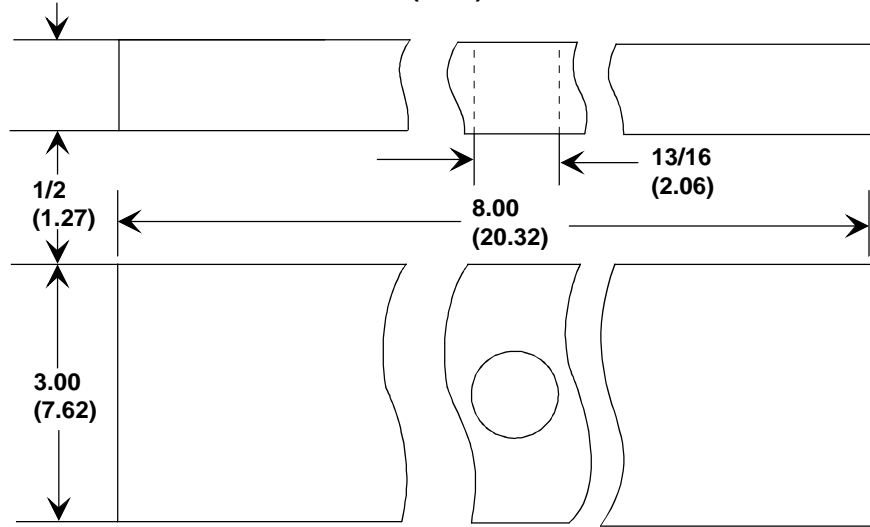

NOTES:

1. FABRICATE FROM NSN 9510-00-189-1619.
2. DRILL 13/16 (2.06 CM) DIAMETER HOLE IN CENTER.
3. ALL DIMENSIONS SHOWN ARE IN INCHES WITH CONVERSION TO CENTIMETERS IN PARENTHESES.
4. FOR INITIAL ASSEMBLY OF BUSHING PULLER, REFER TO FIGURE C-8.
5. FOR FINAL ASSEMBLY OF BUSHING PULLER, REFER TO FIGURE C-3.

Figure C-5. Trail and Bottom Carriage Bushing Puller, Item 3, QQ-S-741.

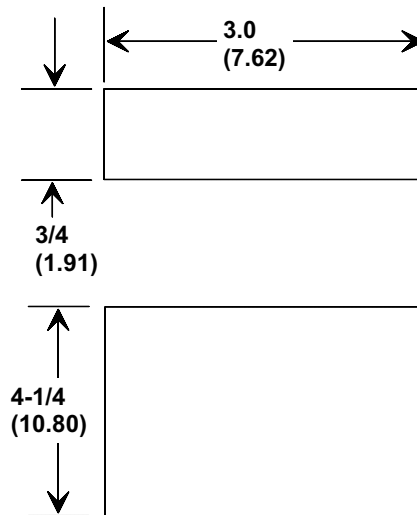

NOTES:

1. FABRICATE FROM NSN 9510-00-189-1649.
2. ALL DIMENSIONS SHOWN ARE IN INCHES WITH CONVERSION TO CENTIMETERS IN PARENTHESES.
3. FOR INITIAL ASSEMBLY OF BUSHING PULLER, REFER TO FIGURE C-8.
4. FOR FINAL ASSEMBLY OF BUSHING PULLER, REFER TO FIGURE C-3.

Figure C-6. Trail and Bottom Carriage Bushing Puller, Item 4, QQ-S-763.

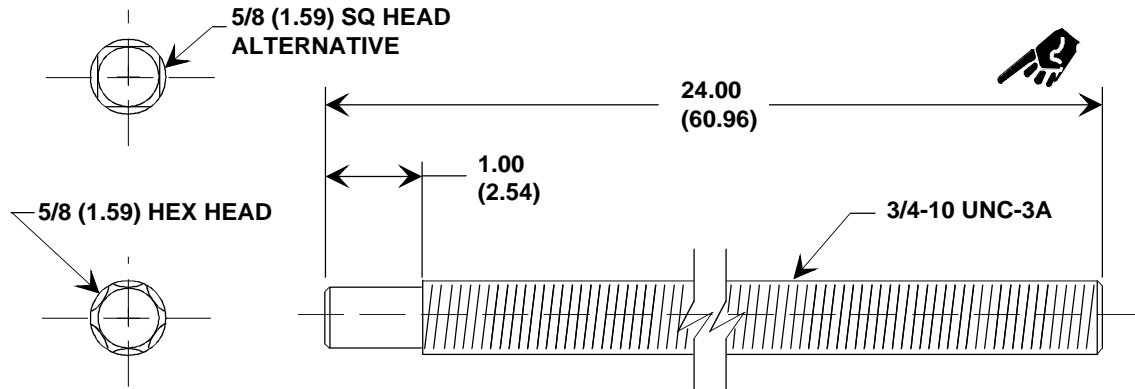

NOTES:

1. FABRICATE FROM NSN 5306-00-364-8525.
2. MACHINE FLATS ON THREADED ROD AS SHOWN (5/8-IN. (1.59 CM) HEX HEAD OR 5/8-IN. (1.59 CM) SQUARE HEAD).
3. ALL DIMENSIONS SHOWN ARE IN INCHES WITH CONVERSION TO CENTIMETERS IN PARENTHESES.
4. FOR FINAL ASSEMBLY OF BUSHING PULLER, REFER TO FIGURE C-3.

Figure C-7. Trail and Bottom Carriage Bushing Puller, Item 5, 1C6197P22 (07482).

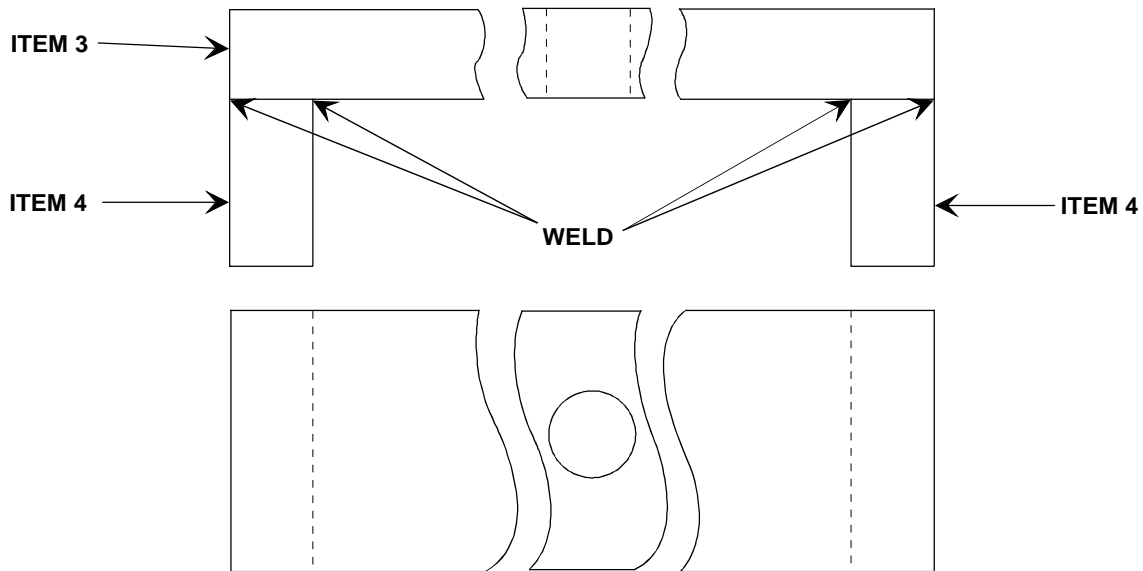

NOTES:

1. WELD TWO PARTS AS SHOWN.
2. FOR FINAL ASSEMBLY OF BUSHING PULLER, REFER TO FIGURE C-3.

Figure C-8. Trail and Bottom Carriage Bushing Puller, Initial Assembly.

C-3. MANUFACTURED ITEMS ILLUSTRATIONS (cont)

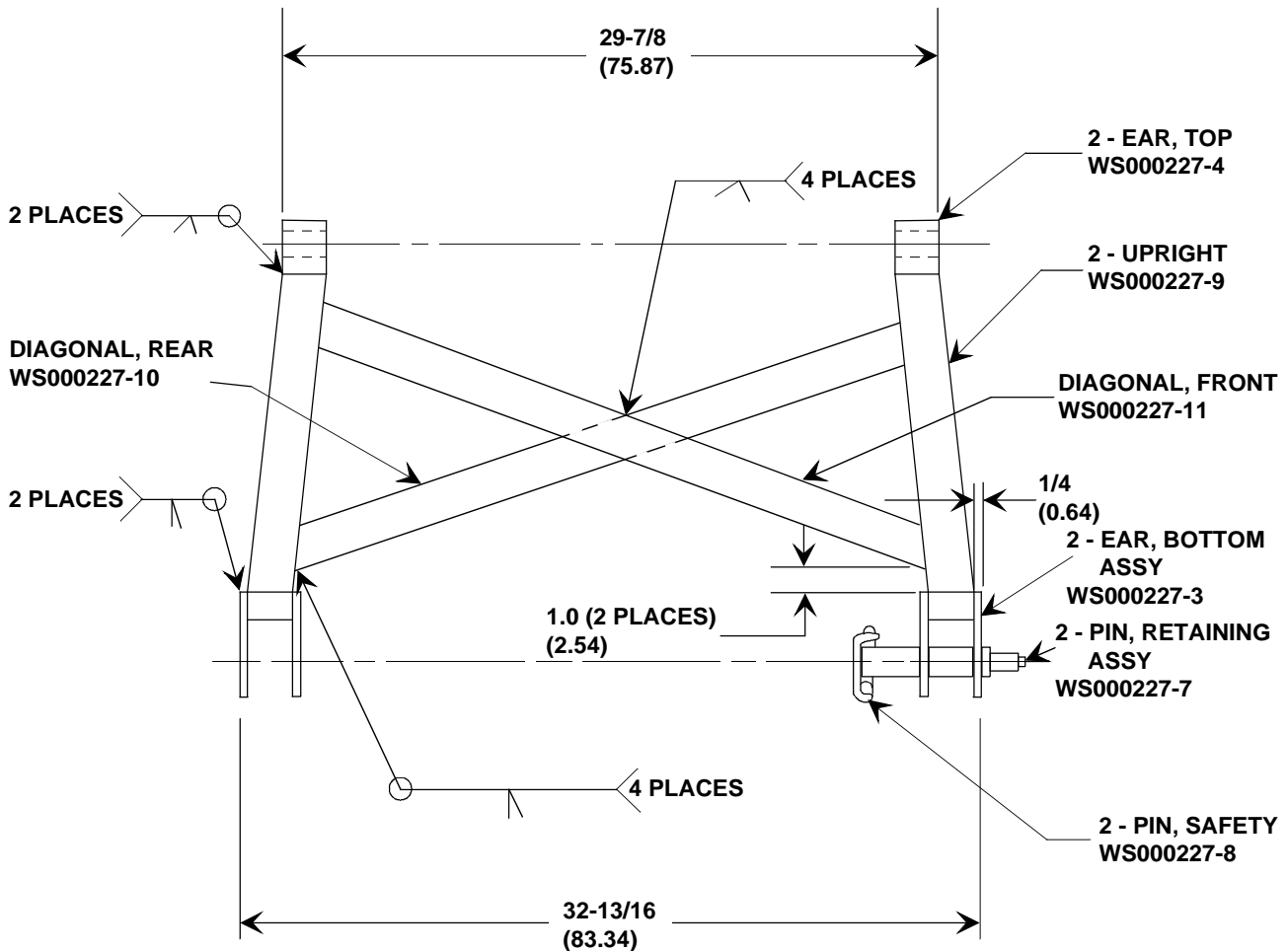

NOTES:

1. REMOVE ALL SHARP CORNERS AND BURRS.
2. FINISH 5.3.1.3 OR 5.3.2.3 PLUS 21.19 OF MIL-STD-171, COLOR OLIVE DRAB NO. 24807 OR APPROVED EQUAL.
3. STENCIL "AIR LIFT ONLY" 1-IN. (2.54 CM) LETTERS, COLOR WHITE (LOCATION OPTIONAL).
4. ALL DIMENSIONS SHOWN ARE IN INCHES WITH CONVERSION TO CENTIMETERS IN PARENTHESES.
5. THE WELD SYMBOL (Δ) INDICATES A GROOVE WELD, FILL GROOVE MADE BY THE CHAMFERS ON MATING PARTS.
6. USE 1/8 OR 5/32 DIAMETER WELD ROD, TYPE E-7018 OR E-6013.

Figure C-9. Travel Lock Assembly, Air Lift WS000227 (Final Assembly).

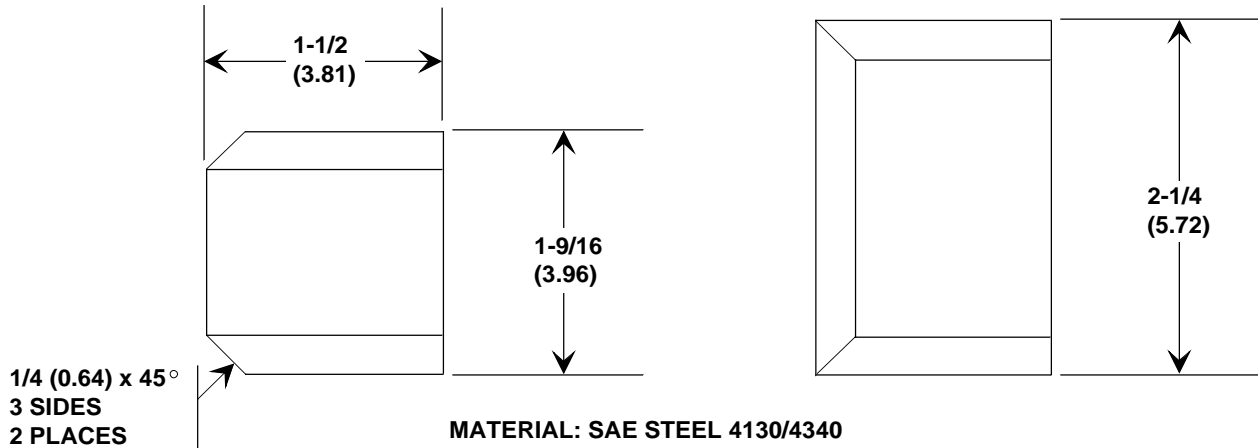

NOTES:

1. FABRICATE FROM NSN 9510-00-595-8340.
2. ALL DIMENSIONS SHOWN ARE IN INCHES WITH CONVERSION TO CENTIMETERS IN PARENTHESES.
3. FOR FINAL ASSEMBLY OF AIR LIFT TRAVEL LOCK ASSEMBLY, REFER TO FIGURE C-9.

Figure C-10. Spacer WS000227-1.

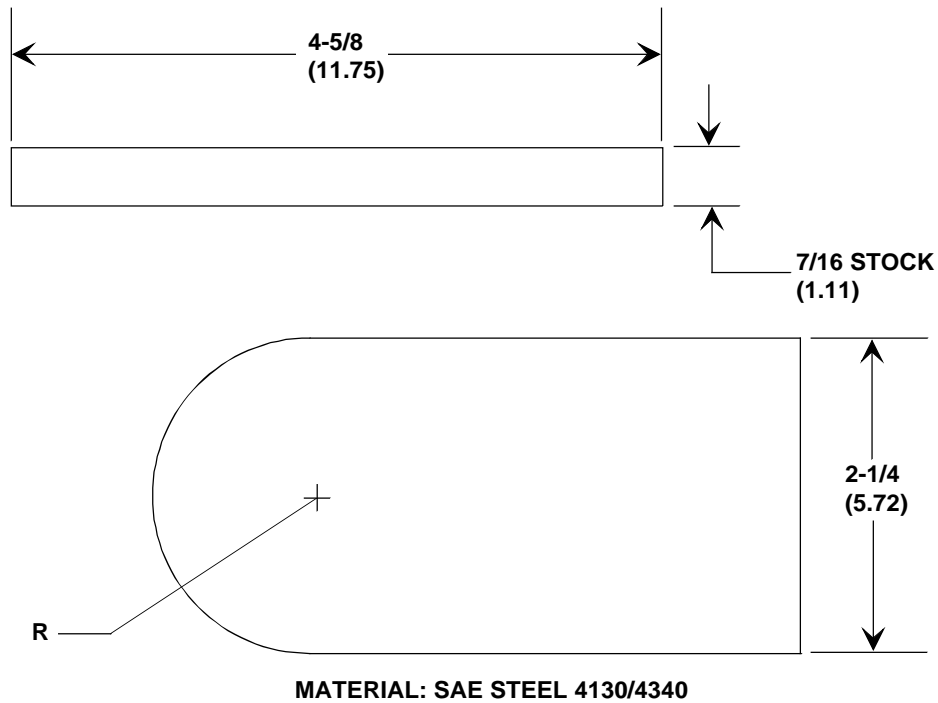

NOTES:

1. FABRICATE FROM NSN 9510-00-555-4710.
2. ALL DIMENSIONS SHOWN ARE IN INCHES WITH CONVERSION TO CENTIMETERS IN PARENTHESES.
3. FOR FINAL ASSEMBLY OF AIR LIFT TRAVEL LOCK ASSEMBLY, REFER TO FIGURE C-9.

Figure C- 11. Ear WS000227-2.

C-3. MANUFACTURED ITEMS ILLUSTRATIONS (cont)

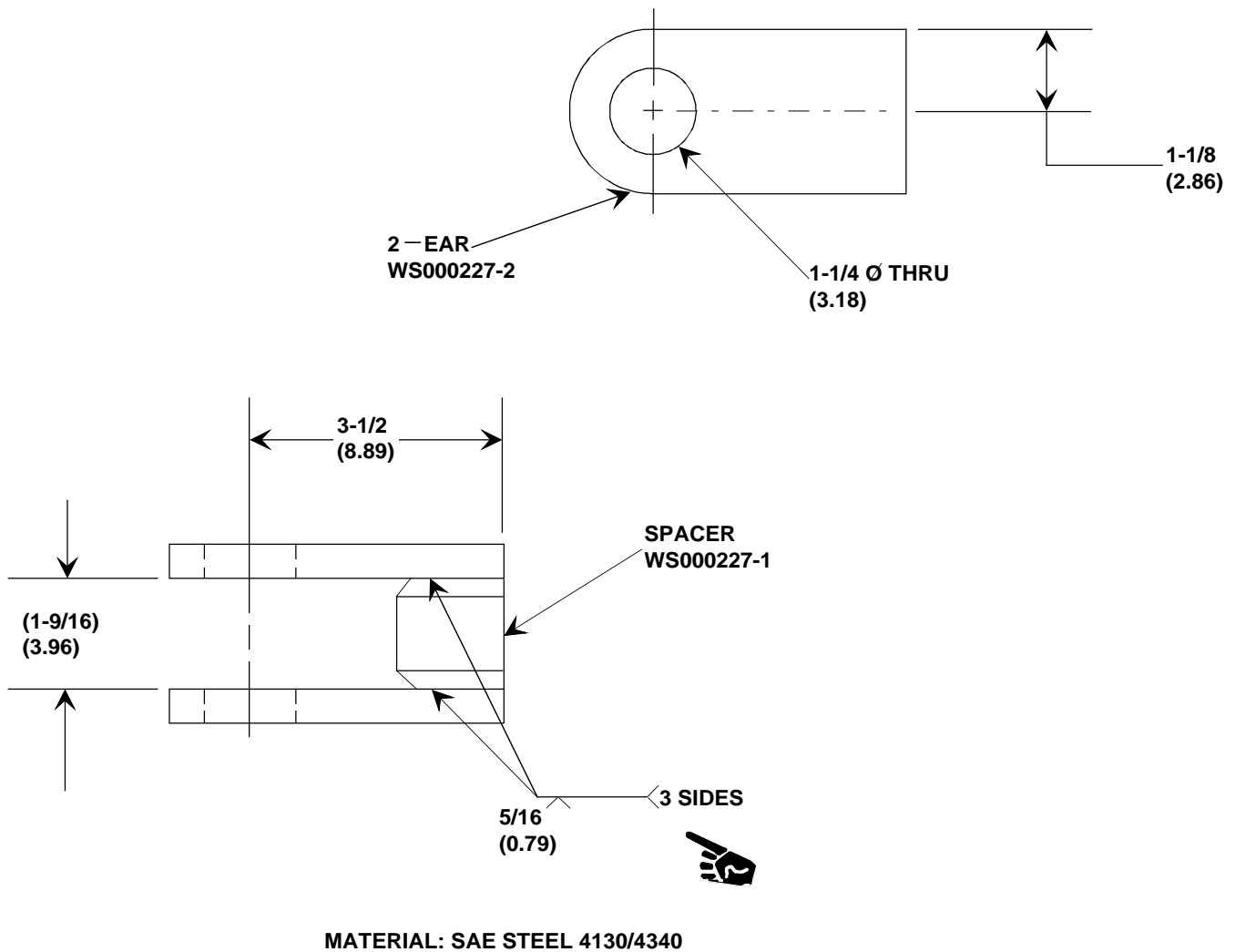

NOTES:

1. ASSEMBLE WS000227-1 (FIG. C-10) AND WS000227-2 (FIG. C-11) AS SHOWN.
2. ALL DIMENSIONS SHOWN ARE IN INCHES WITH CONVERSION TO CENTIMETERS IN PARENTHESES.
3. FOR FINAL ASSEMBLY OF AIR LIFT TRAVEL LOCK ASSEMBLY, REFER TO FIGURE C-9.

Figure C-12. Ear, Bottom, Assembly WS000227-3.

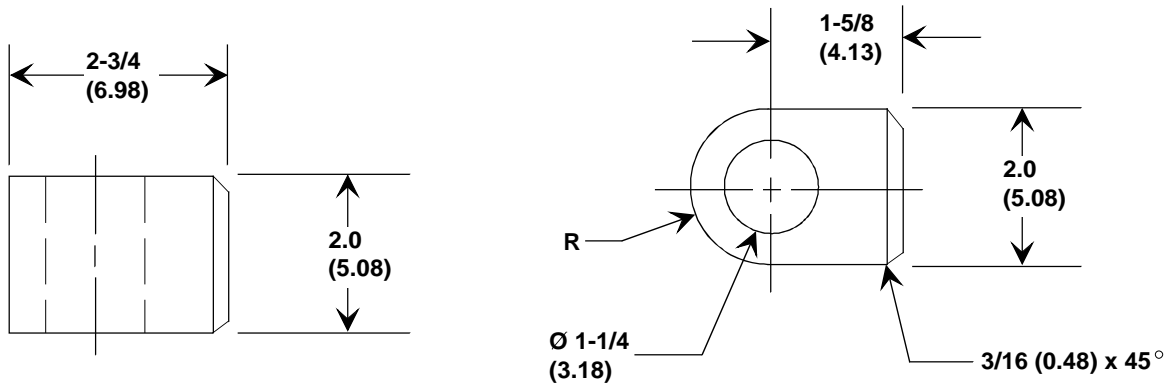

MATERIAL: SAE STEEL 4130/4340

NOTES:

1. FABRICATE FROM NSN 9510-00-288-6062.
2. ALL DIMENSIONS SHOWN ARE IN INCHES WITH CONVERSION TO CENTIMETERS IN PARENTHESES.
3. FOR FINAL ASSEMBLY OF AIR LIFT TRAVEL LOCK ASSEMBLY, REFER TO FIGURE C-9.

Figure C- 13. Ear, Top Assembly WS000227-4.

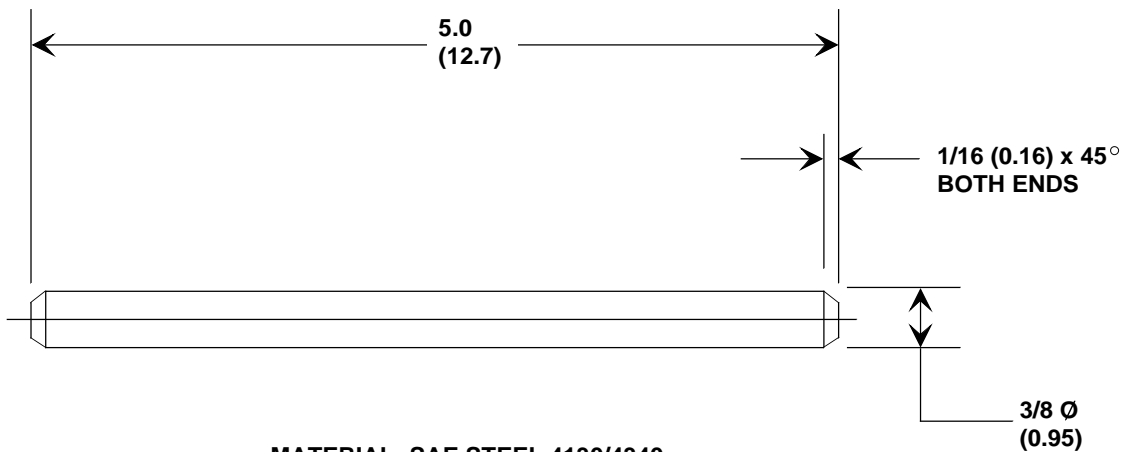

MATERIAL: SAE STEEL 4130/4340

NOTES:

1. FABRICATE FROM NSN 9510-00-294-9666.
2. ALL DIMENSIONS SHOWN ARE IN INCHES WITH CONVERSION TO CENTIMETERS IN PARENTHESES.
3. FOR FINAL ASSEMBLY OF AIR LIFT TRAVEL LOCK ASSEMBLY, REFER TO FIGURE C-9.

Figure C-14. Handle WS000227-5.

C-3. MANUFACTURED ITEMS ILLUSTRATIONS (cont)

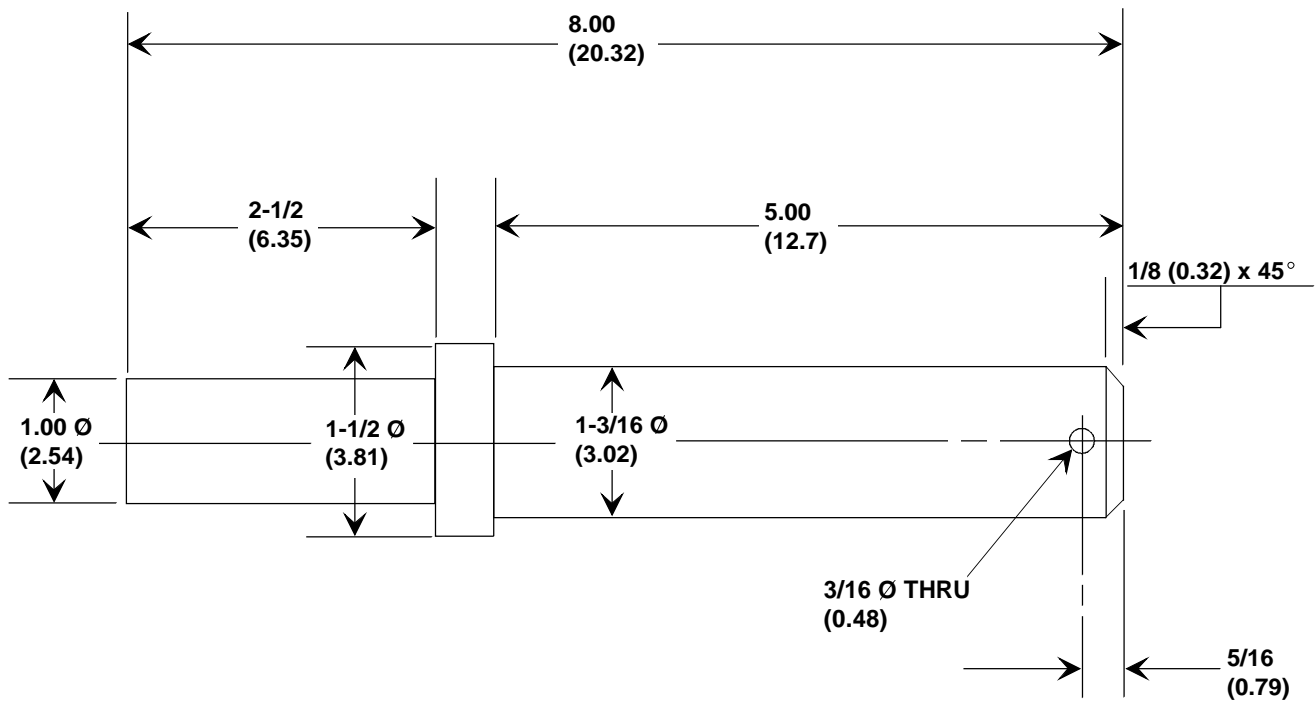

MATERIAL: SAE STEEL 4130/4340

NOTES:

1. FABRICATE FROM NSN 9510-00-288-5437.
2. ALL DIMENSIONS SHOWN ARE IN INCHES WITH CONVERSION TO CENTIMETERS IN PARENTHESES.
3. FOR FINAL ASSEMBLY OF AIR LIFT TRAVEL LOCK ASSEMBLY, REFER TO FIGURE C-9.

Figure C-15. Pin WS000227-6.

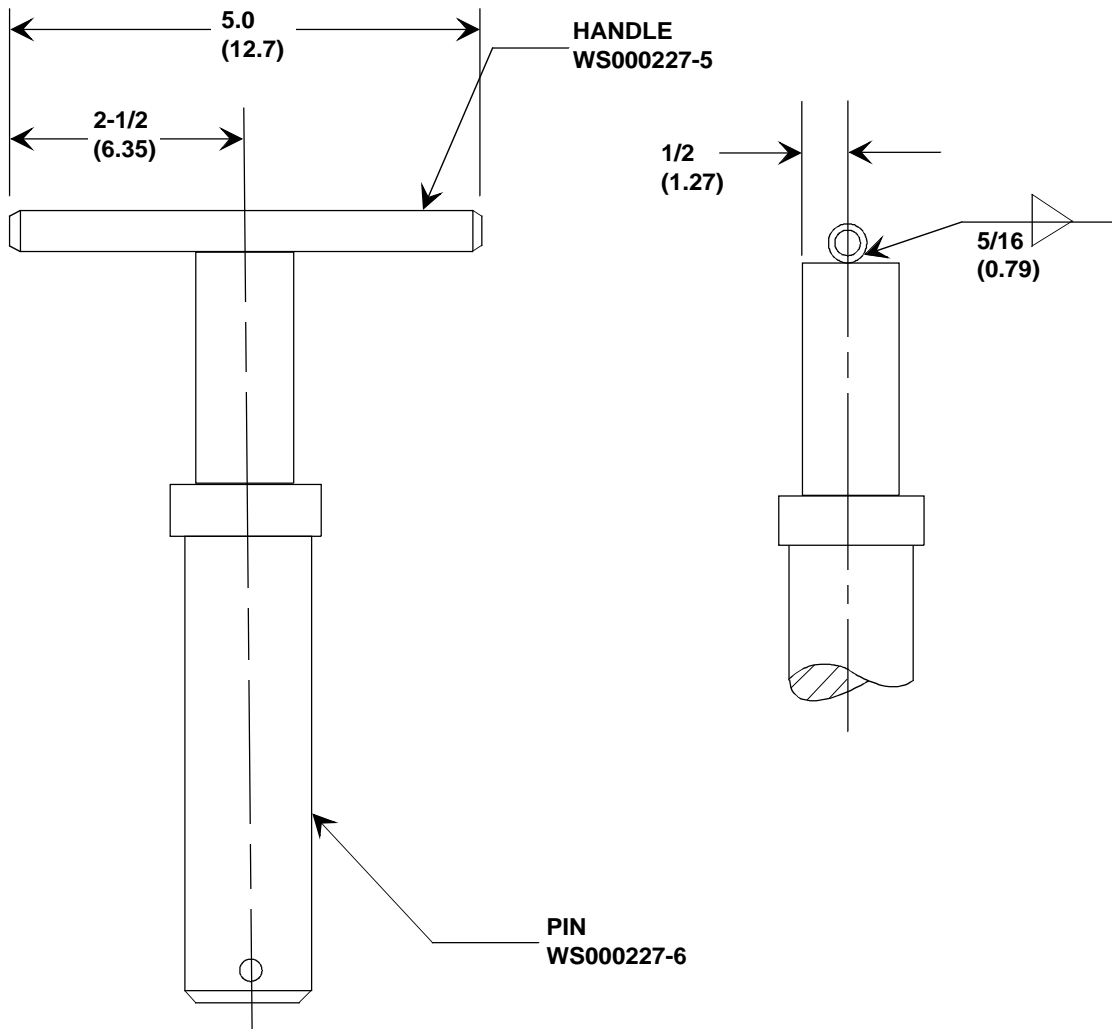

NOTES:

1. ASSEMBLE WS000227-5 (FIG. C-14) AND WS000227-6 (FIG. C-15) AS SHOWN.
2. ALL DIMENSIONS SHOWN ARE IN INCHES WITH CONVERSION TO CENTIMETERS IN PARENTHESES.
3. FOR FINAL ASSEMBLY OF AIR LIFT TRAVEL LOCK ASSEMBLY, REFER TO FIGURE C-9.

Figure C-16. Pin, Retaining Assembly WS000227-7.

C-3. MANUFACTURED ITEMS ILLUSTRATIONS (cont)

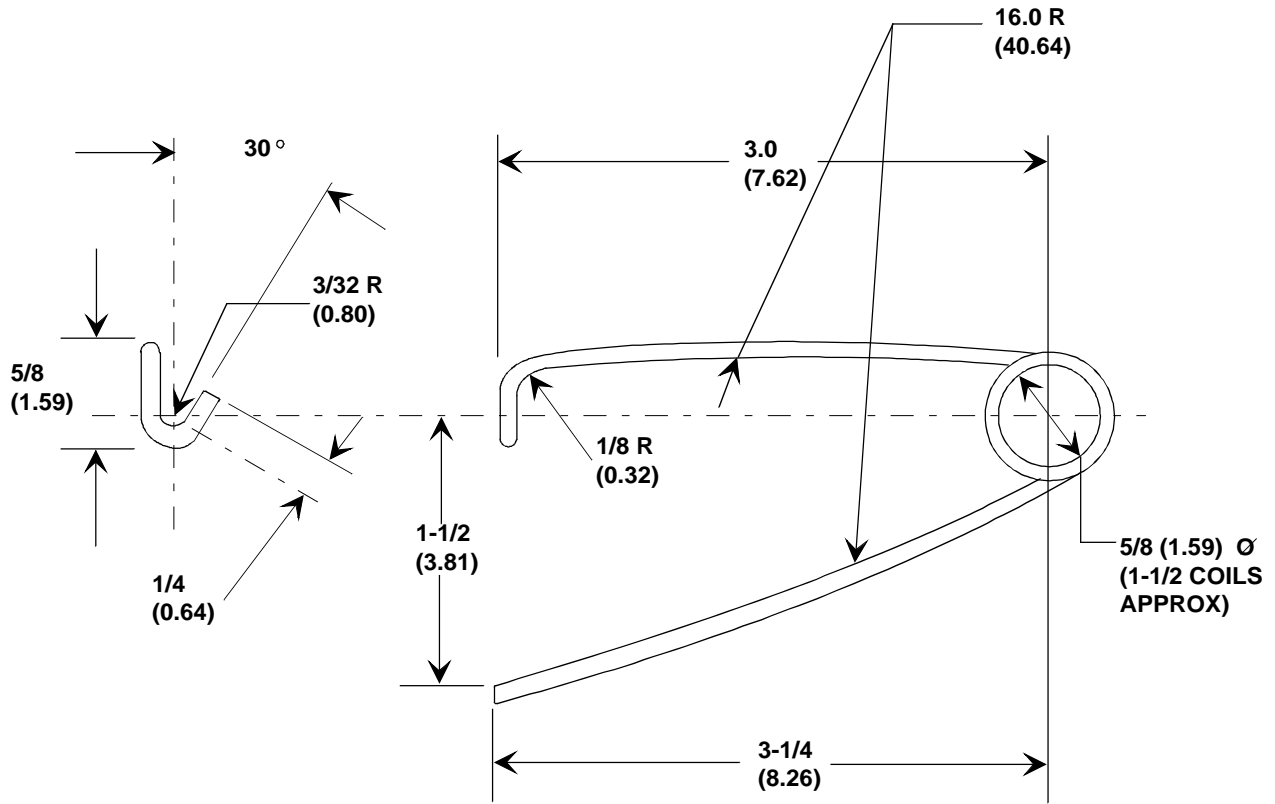

**MATERIAL: .095 (0.24) \varnothing (33 GAGE) SAE 1085 MUSIC WIRE (STRESS RELIEVE AFTER FORMING)
 OR
 #3 SAFETY PIN FASTENER, WESTERN WIRE PRODUCTS CO. OR APPROVED EQUAL.**

NOTES:

1. FABRICATE FROM NSN 5315-01-032-7107.
2. ALL DIMENSIONS SHOWN ARE IN INCHES WITH CONVERSION TO CENTIMETERS IN PARENTHESES.
3. FOR FINAL ASSEMBLY OF AIR LIFT TRAVEL LOCK ASSEMBLY, REFER TO FIGURE C-9.

Figure C-17. Pin, Safety WS000227-8.

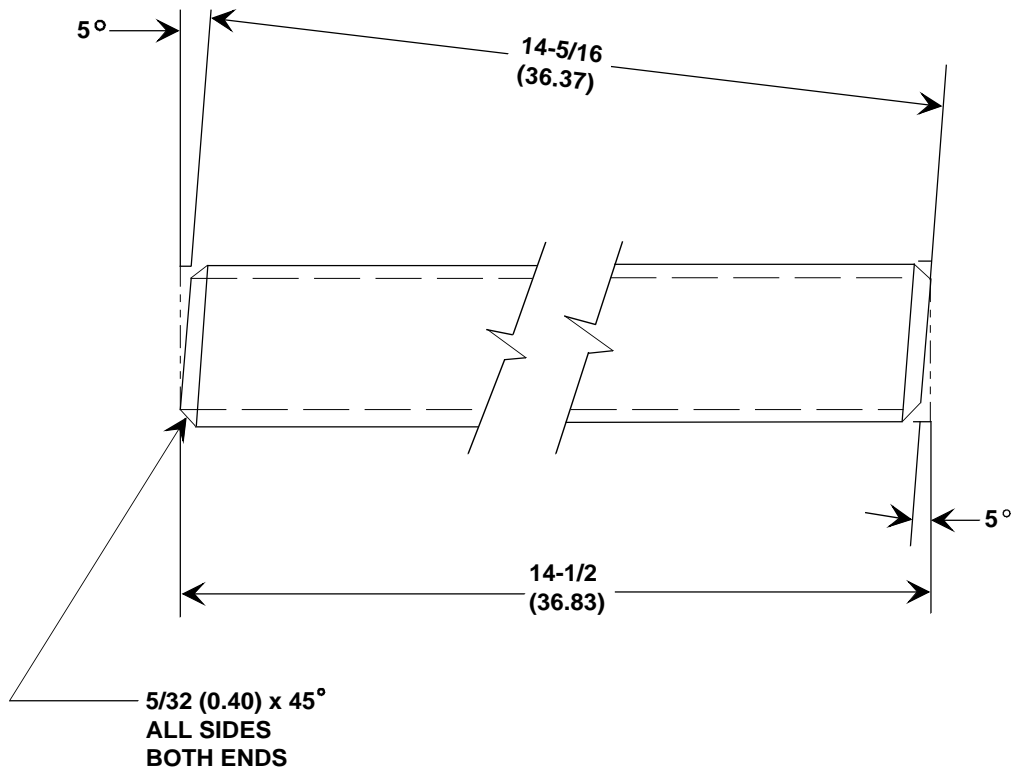

MATERIAL: TUBING, STRUCTURAL, 2 SQ x 3/16 (0.48) WALL PER ASTM-A513 OR QQ-T-00825.

NOTES:

1. FABRICATE FROM NSN 4710-00-233-9838.
2. ALL DIMENSIONS SHOWN ARE IN INCHES WITH CONVERSION TO CENTIMETERS IN PARENTHESES.
3. FOR FINAL ASSEMBLY OF AIR LIFT TRAVEL LOCK ASSEMBLY, REFER TO FIGURE C-9.

Figure C-18. Upright WS000227-9.

C-3. MANUFACTURED ITEMS ILLUSTRATIONS (cont)

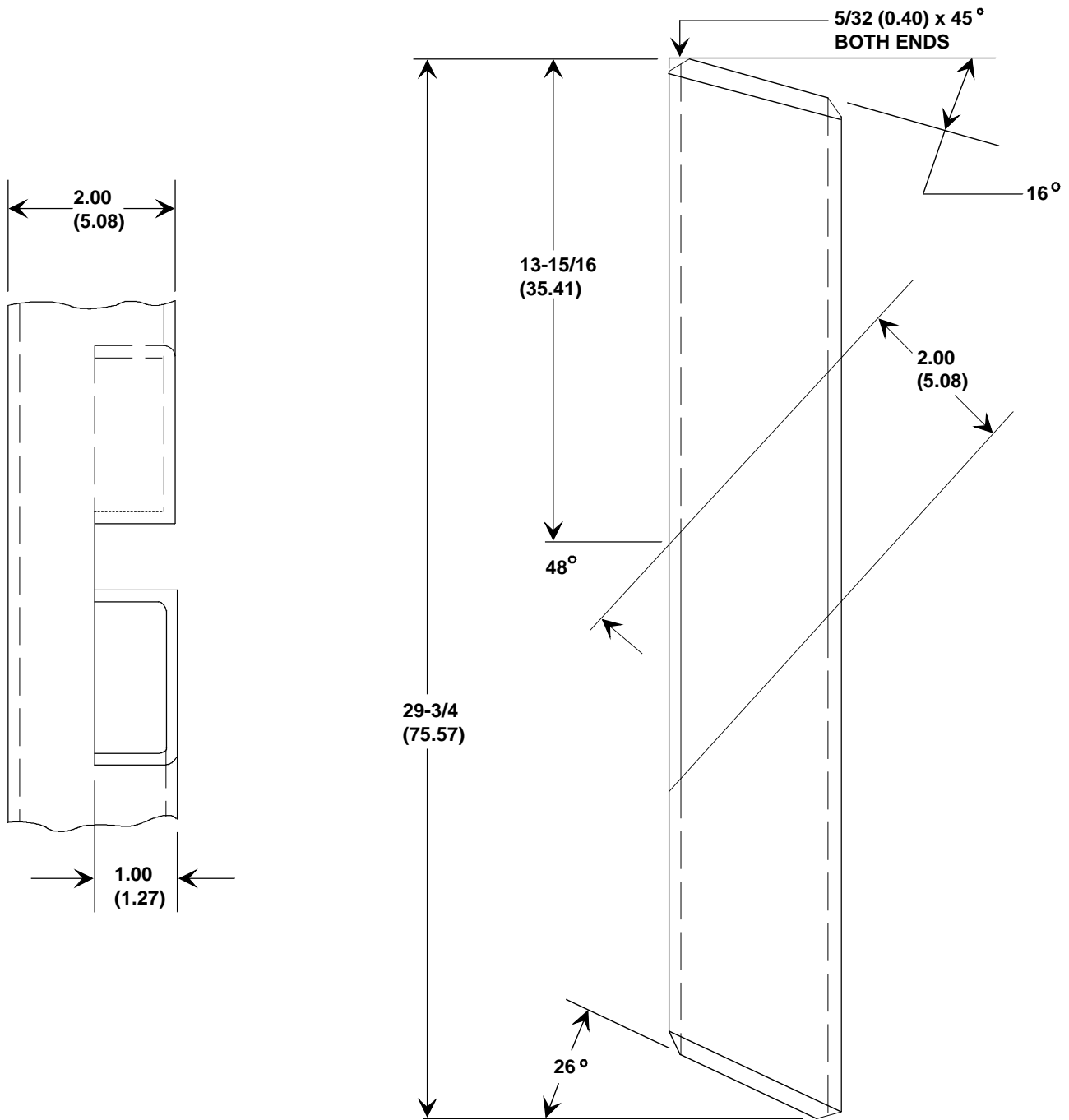

MATERIAL: TUBING, STRUCTURAL, 2 SQ x 3/16 (0.48) WALL PER ASTM-A513 OR QQ-T-00825.

NOTES:

1. FABRICATE FROM NSN 4710-00-233-9838.
2. ALL DIMENSIONS SHOWN ARE IN INCHES WITH CONVERSION TO CENTIMETERS IN PARENTHESES.
3. FOR FINAL ASSEMBLY OF AIR LIFT TRAVEL LOCK ASSEMBLY, REFER TO FIGURE C-9.

Figure C-19. Diagonal, Rear WS000227-10.

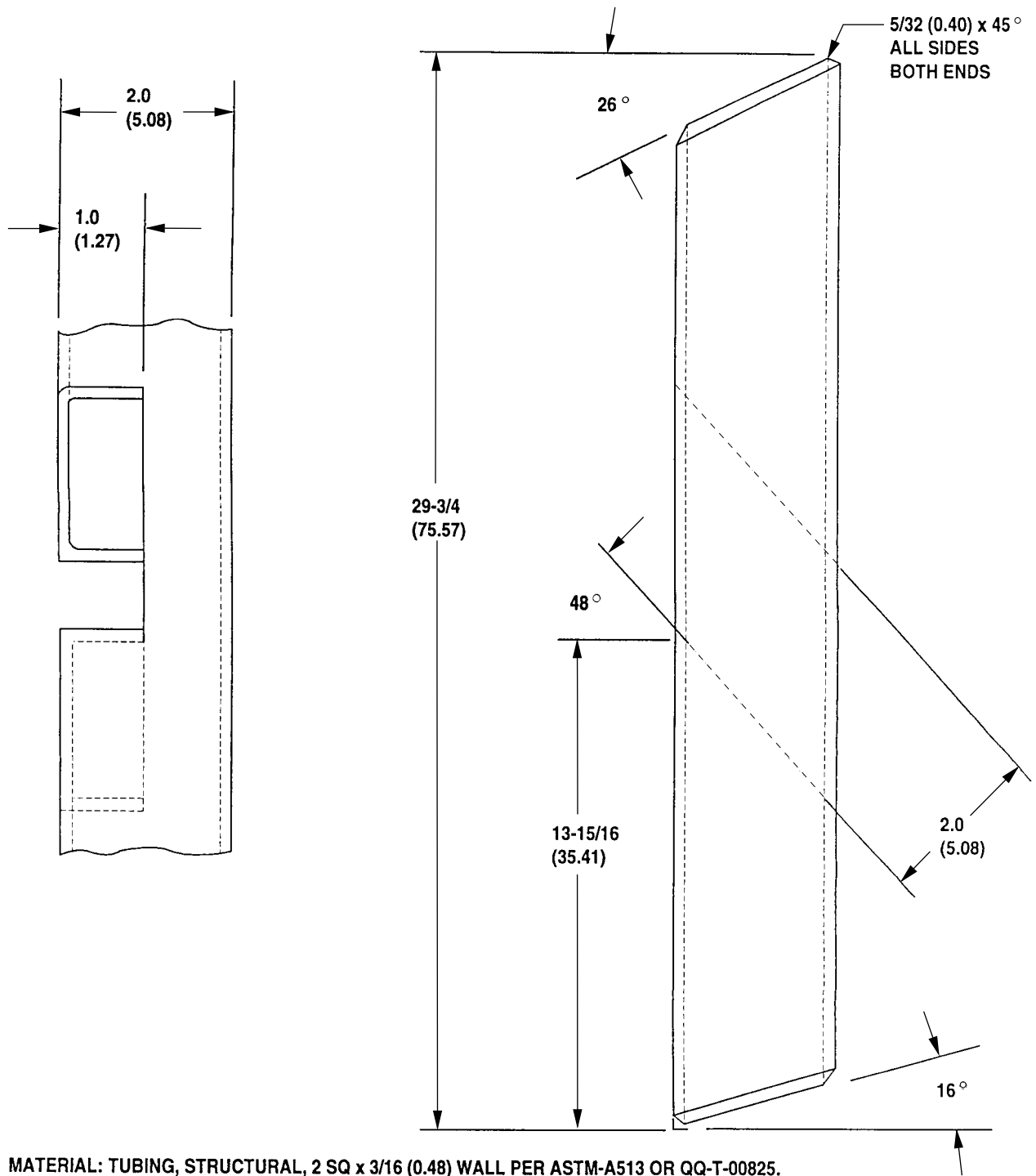

NOTES:

1. FABRICATE FROM NSN 4710-00-233-9838.
2. ALL DIMENSIONS SHOWN ARE IN INCHES WITH CONVERSION TO CENTIMETERS IN PARENTHESES.
3. FOR FINAL ASSEMBLY OF AIR LIFT TRAVEL LOCK ASSEMBLY, REFER TO FIGURE C-9.

Figure C-20. Diagonal, Front WS000227-11.

C-3. MANUFACTURED ITEMS ILLUSTRATIONS (cont)

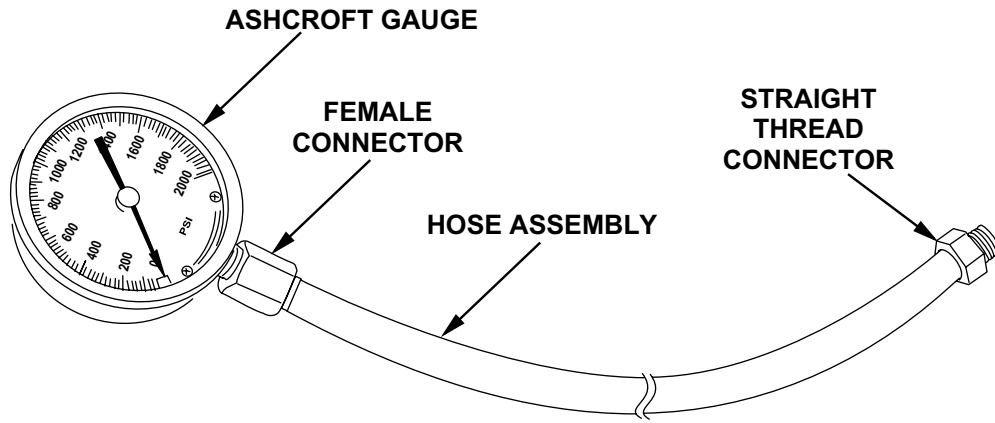

NOTES:

Fabricate from:

1. Hose assembly, nonmetallic, NSN 4720-00-289-6335.
2. Straight thread connector, NSN 4730-00-258-1864, P/N MS51525B4-6, CAGEC 96906.
3. Ashcroft general service gauge, Type 1009, Grade 1A, 0-5000 psi standard pressure range.
4. Parker female connector, P/N 4-4 GTX.

Figure C-21. Fabricated Gauge.

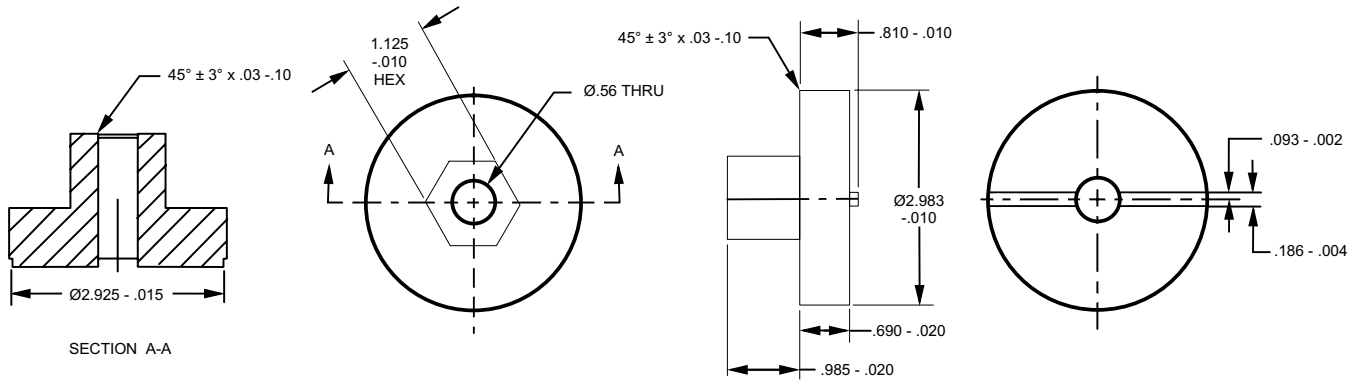

NOTES:

1. APPLICABLE STANDARDS/SPECIFICATIONS: MIL-STD-100E.
2. MATERIAL: STEEL, ASTM A108 OR A567 GRADE UNS G10100 THROUGH G10400.
3. UNLESS OTHERWISE SPECIFIED, ALL EDGES AND CORNERS SHALL BE BROKEN .01 + .01.
4. UNLESS OTHERWISE SPECIFIED, FINISH $\sqrt{125}$.
5. 9/16 X 18 BOLT, 2-1/2 IN. LONG, USED WITH THIS ITEM.

Figure C-22A. Purging Tool / Back Removal Tool 12994452.

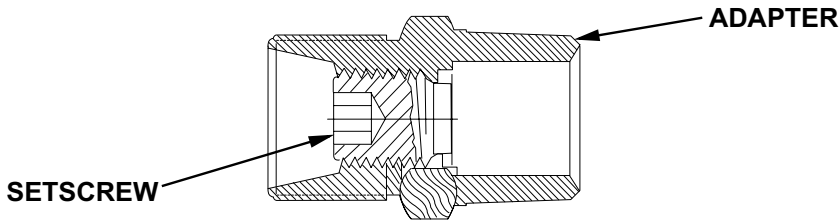

NOTES:

FABRICATE FROM:

1. ADAPTER, STRAIGHT PIPE, NSN 4730-00-430-4507.
2. SETSCREW, NSN 5303-00-058-9377.
3. TAPE, ANTISEIZING, NSN 8030-00-889-3534.
4. DRILL AND TAP INSIDE OF ADAPTER FOR .250-20 THREAD. APPLY ANTISEIZING TAPE TO THREADS OF SETSCREW AND INSTALL INTO ADAPTER.

Figure C-22C. Purging Tool / Fabricated Plug.

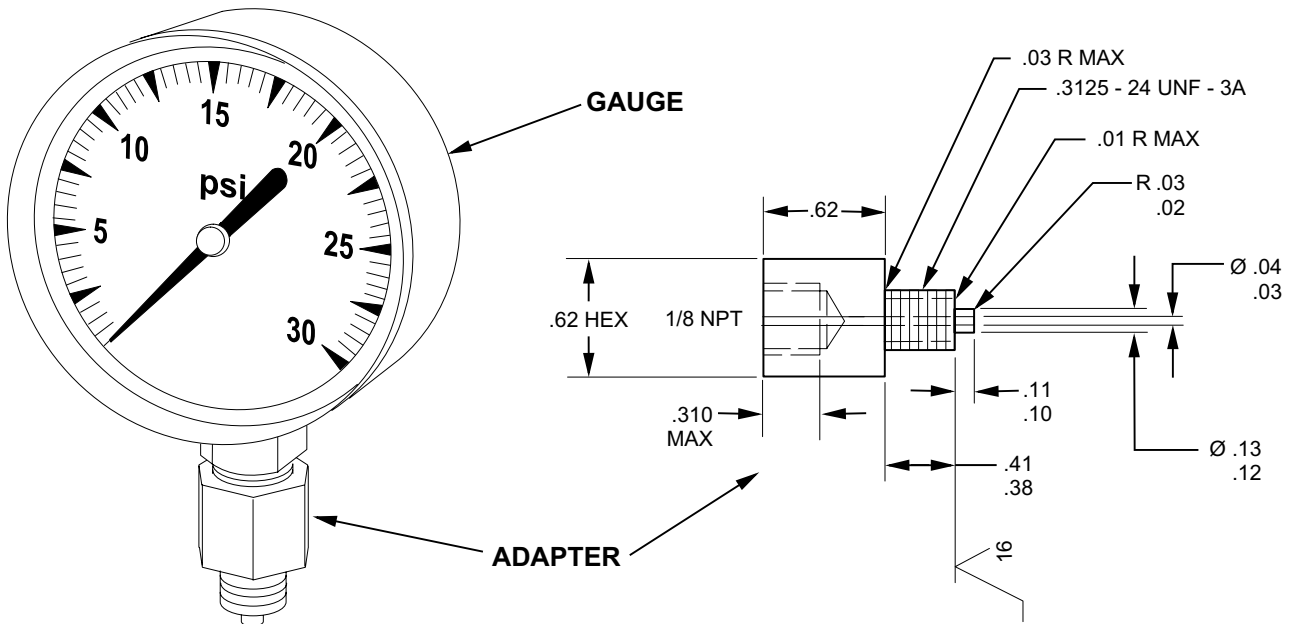

NOTES:

1. FABRICATE ADAPTER AS ILLUSTRATED.
2. APPLICABLE STANDARDS/SPECIFICATIONS: MIL-STD-100E.
3. MATERIAL: STEEL, ASTM A108 OR A567 GRADE UNS G10100 THROUGH G10400.
4. UNLESS OTHERWISE SPECIFIED, ALL EDGES AND CORNERS SHALL BE BROKEN .01 + .01.
5. UNLESS OTHERWISE SPECIFIED, FINISH $\sqrt{125}$.
6. TAPE, ANTISEIZING, NSN 8030-00-889-3534.
7. ASHCROFT COMMERCIAL GAUGE, TYPE 1005H, GRADE B, 0-30 PSI PRESSURE RANGE.
8. APPLY ANTISEIZING TAPE TO THREADS OF GAUGE AND INSTALL INTO ADAPTER.

Figure C-22D. Purging Tool / Pressure Gauge and Adapter.

C-3. MANUFACTURED ITEMS ILLUSTRATIONS (cont)

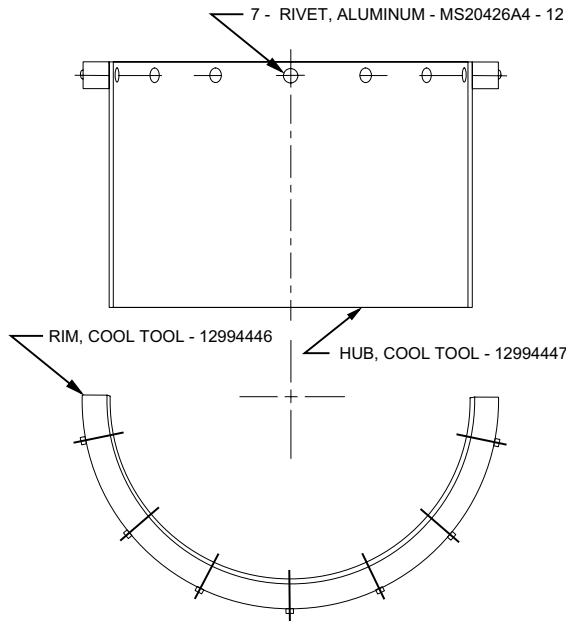

COOL TOOL ASSEMBLY 12994445

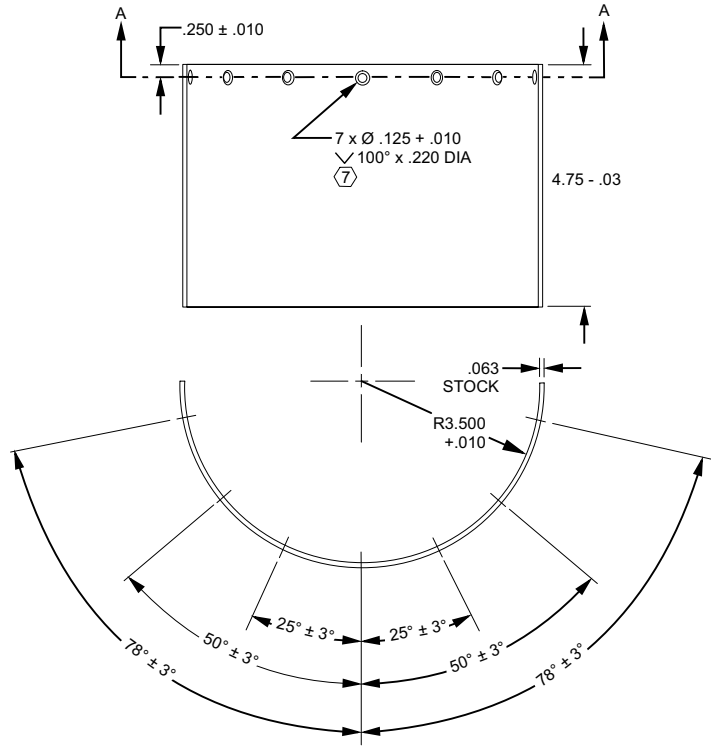

HUB, COOL TOOL 12994447

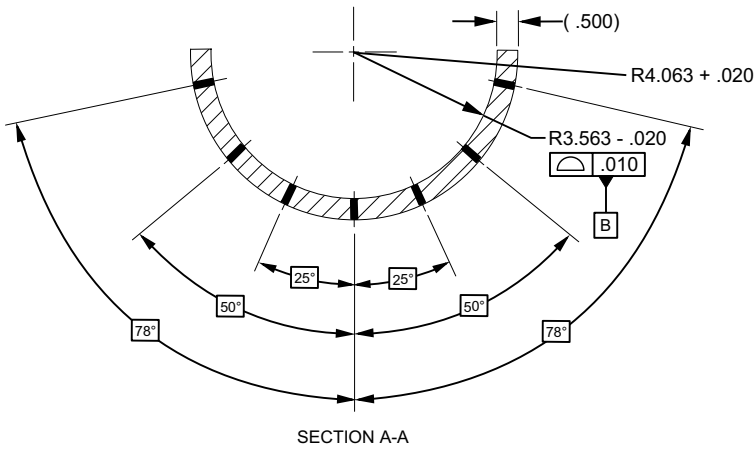
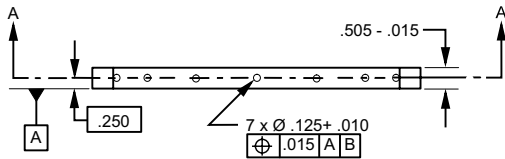

RIM, COOL TOOL 12994446

NOTES:

1. FABRICATE HUB AND RIM AS ILLUSTRATED.
2. APPLICABLE STANDARDS/SPECIFICATIONS: MIL-STD-100E AND AMSE Y14.5-1994.
3. MATERIAL: ALUMINUM, ASTM B209, B211, OR B221 ALLOY 6061 T6 OR T65111.
4. UNLESS OTHERWISE SPECIFIED, ALL EDGES AND CORNERS SHALL BE BROKEN .01 + .01.
5. UNLESS OTHERWISE SPECIFIED, FINISH $\sqrt{125}$.
6. ALL DIMENSIONS APPLY TO RESTRAINED CONDITION.
7. HUB HOLES MUST ALIGN WITH HOLE PATTERN IN RIM.
8. ASSEMBLE HUB AND RIM USING SEVEN RIVETS, ALUMINUM MS20426A4-12.

Figure C-23. Cool Tool Hub, Rim, and Assembly.

APPENDIX D

TORQUE LIMITS

D-1. TORQUE REQUIREMENTS

Unless specified, use the following charts when torquing threaded fasteners.

DRY TORQUE LIMITS FOR METRIC FASTENERS

SIZE BOLT SHANK		TORQUE					
		METRIC GRADE 8.9		METRIC GRADE 10.9		METRIC GRADE 12.9	
DIA INCHES	MILLIMETERS	FOOT POUNDS	NEWTON METERS	FOOT POUNDS	NEWTON METERS	FOOT POUNDS	NEWTON METERS
0.157	4	2	3	3	4	4	5
0.197	5	4	5	6	8	7	9
0.237	6	7	9	10	14	11	15
0.276	7	11	15	16	32	20	27
0.315	8	18	24	25	34	29	39
0.394	10	32	43	47	64	56	79
0.473	12	58	79	83	113	100	136
0.630	16	144	195	196	266	235	319
0.709	18	190	258	269	365	323	438
0.788	20	260	353	366	496	440	597
0.867	22	368	499	520	705	678	919
0.946	24	470	637	664	900	794	1077
1.064	27	707	959	996	1351	1235	1675
1.162	30	967	1311	1357	1840	1630	2210

TORQUE LIMITS FOR DRY FASTENERS

SIZE			TORQUE							
			SAE GRADE NO. 2		SAE GRADE NO. 5		SAE GRADE NO. 6 OR 7		SAE GRADE NO. 8	
DIA INCHES	THREADS PER INCH	MILLI-METERS	FOOT POUNDS	NEWTON METERS	FOOT POUNDS	NEWTON METERS	FOOT POUNDS	NEWTON METERS	FOOT POUNDS	NEWTON METERS
1/4	20	6.35	5	7	8	11	10	14	12	16
1/4	28	6.35	6	9	10	14	12	16	14	19
5/16	18	7.94	11	15	17	23	21	28	25	34
5/16	24	7.94	12	16	19	26	24	33	25	34
3/8	16	9.53	20	27	30	41	40	54	45	61
3/8	24	9.53	23	31	35	47	45	61	50	68
7/16	14	11.11	30	41	50	68	60	81	70	95
7/16	20		35	47	55	75	70	95	90	108
1/2	13	12.70	50	68	75	102	95	129	110	149
1/2	20		55	75	90	122	100	135	120	163
9/16	12	14.29	65	85	110	149	135	183	150	203
9/16	18		75	102	120	163	150	203	170	231
5/8	11	15.86	90	122	150	203	190	258	220	298
5/8	18		100	136	180	244	210	285	240	325
3/4	10	19.05	160	217	260	353	240	434	380	515
3/4	16		180	244	300	407	360	488	420	597
7/8	9	22.23	140	190	400	542	520	705	600	814
7/8	14		155	210	440	597	580	786	660	895
1	8	25.40	220	298	580	786	800	1085	900	1220
1	12		240	325	640	868	860	1166	1000	1350
1-1/8	7	25.58	300	407	800	1085	1120	1519	1280	1736
1-1/8	12		340	461	880	1193	1260	1709	1440	1953
1-1/4	7	31.75	420	570	1120	1519	1580	2142	1820	2468
1-1/4	12		460	624	1240	1681	1760	2387	2000	2712
1-3/8	6	34.93	560	759	1460	1980	2080	2820	2380	3227
1-3/8	12		640	868	1680	2278	2360	3227	2720	3688
1-1/2	6	38.10	740	1003	1940	2631	2780	3770	3160	4285
1-1/2	12		840	1139	2200	2983	3100	4204	3560	4827

TORQUE LIMITS FOR DRY FASTENERS

SIZE			TORQUE							
			SAE GRADE NO. 2		SAE GRADE NO. 5		SAE GRADE NO. 6 OR 7		SAE GRADE NO. 8	
DIA INCHES	THREADS PER INCH	MILLI-METERS	FOOT POUNDS	NEWTON METERS	FOOT POUNDS	NEWTON METERS	FOOT POUNDS	NEWTON METERS	FOOT POUNDS	NEWTON METERS
1/4	20	6.35	4	6	6	8	8	11	9	12
1/4	28	6.35	5	7	7	9	9	12	10	14
5/16	18	7.94	8	11	3	15	16	22	18	24
5/16	24	7.94	9	12	14	19	18	34	20	27
3/8	16	9.53	15	20	23	31	20	41	35	47
3/8	24	9.53	17	23	25	34	30	41	35	47
7/16	14	11.11	24	33	35	47	45	61	55	75
7/16	20		25	34	40	54	50	68	60	81
1/2	13	12.70	35	47	55	76	70	95	80	108
1/2	20		40	54	65	88	80	108	90	122
9/16	12	14.29	50	68	80	105	100	138	110	149
9/16	18		55	75	90	122	110	149	130	176
5/8	11	15.88	70	95	110	149	140	190	170	231
5/8	18		80	108	130	176	160	217	180	244
3/4	10	19.05	120	163	200	271	240	325	280	380
3/4	16		140	190	220	298	280	380	320	434
7/8	9	22.23	110	149	300	407	400	542	460	624
7/8	14		120	163	320	434	440	597	500	678
1	8	25.40	160	217	440	597	600	814	680	922
1	12		170	231	480	651	650	895	740	1003
1-1/8	7	25.58	220	398	600	814	840	1139	960	1302
1-1/8	12		260	353	660	895	940	1275	1080	1464
1-1/4	7	31.75	320	434	840	1139	1100	1492	1350	1844
1-1/4	12		360	488	920	1248	1320	1790	1500	2034
1-3/8	6	34.93	420	570	1100	1492	1560	2115	1780	2414
1-3/8	12		460	624	1260	1709	1780	2414	2040	2766
1-1/2	6	38.10	560	760	1460	1980	2080	2820	2360	3200
1-1/2	12		620	841	1640	2224	2320	3146	2660	3607

APPENDIX E

LUBRICATION INSTRUCTIONS

NOTES

Intervals are based on normal operation. You should lube more during constant use and lube less during inactive periods. Relubricate after washing, fording (fresh or salt water), or contact with salt water spray. Clean fittings before lubricating. Clean parts with cleaning compound. Dry before lubricating. DO NOT overlubricate; wipe off excess lubricant.

Dotted lines indicate lubrication points on both sides of the equipment. The level of maintenance responsible for each lube instruction is shown, and this appendix has three sections based on lubrication intervals. An overall view showing lubrication points precedes the set of detailed notes for each interval.

Daily lubing means once each day after weapon has been fired.

KEY

MAINTENANCE LEVEL

F Direct Support

LUBRICATION POINTS

WTR

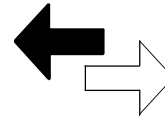

PL-S or CLP

(as directed in procedure)

LUBRICANTS

WTR Grease, Aircraft, General Purpose, Wide Temperature Range, MIL-G-81322
OHT Hydraulic Fluid, Petroleum Base, MIL-H-6083
GMD Grease, Molybdenum Disulfide, MIL-G-21164

QUARTERLY

LUBRICANT

LUBRICANT

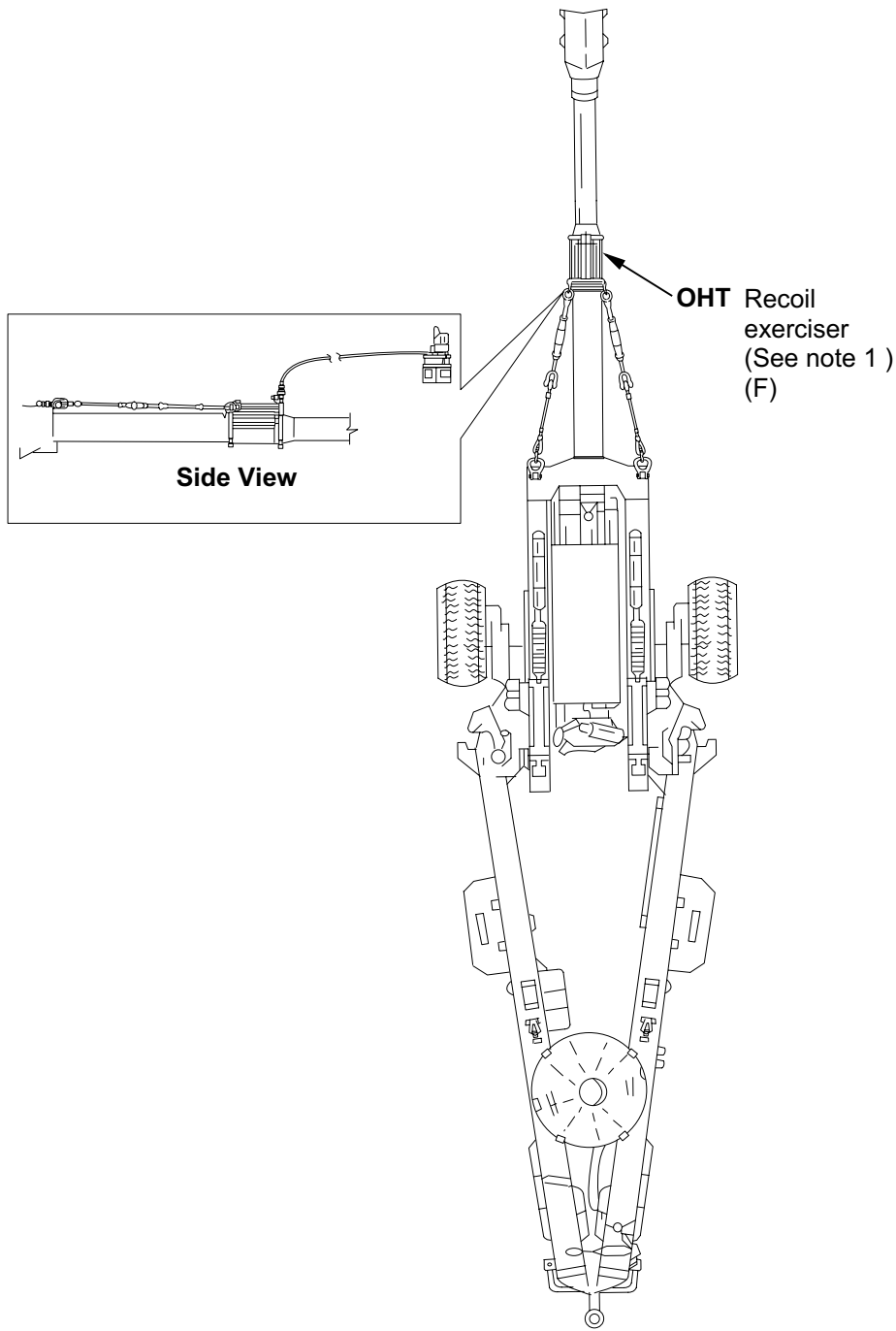

TOP VIEW

NOTE 1

RECOIL/REPLENISHER EXERCISER (F)

Follow exerciser instructions per Paragraph 2-18.1.

ANNUALLY

LUBRICANT

LUBRICANT

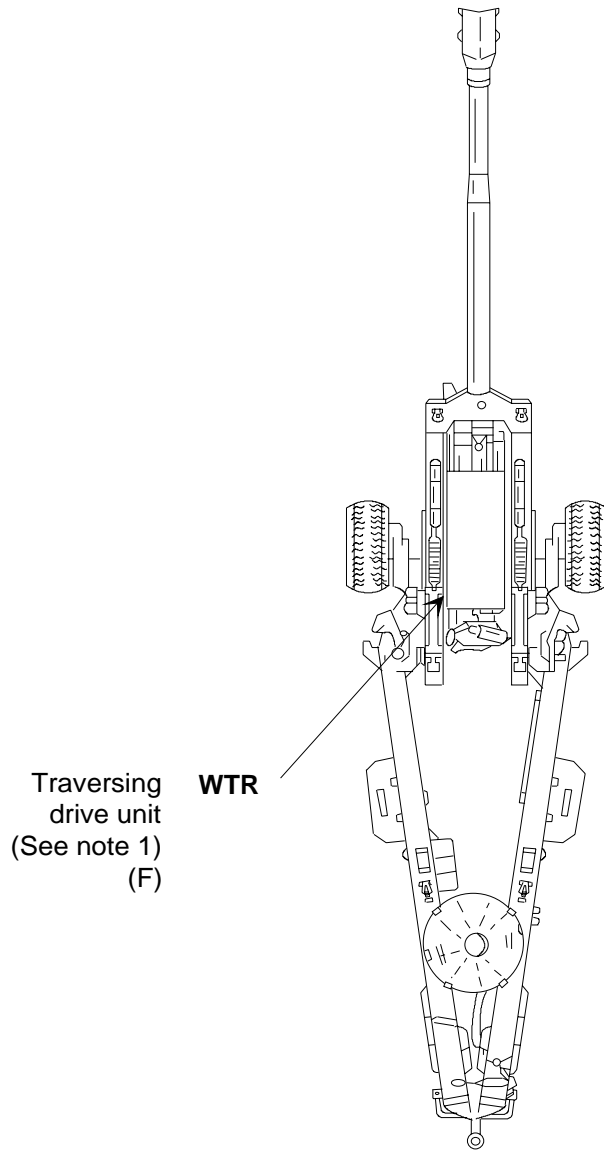

Traversing
drive unit
(See note 1)
(F)

WTR

TOP VIEW

NOTE 1

TRAVERSING DRIVE UNIT (F)

Remove, disassemble, clean, lube with WTR, and reassemble.

ANNUALLY

LUBRICANT

LUBRICANT

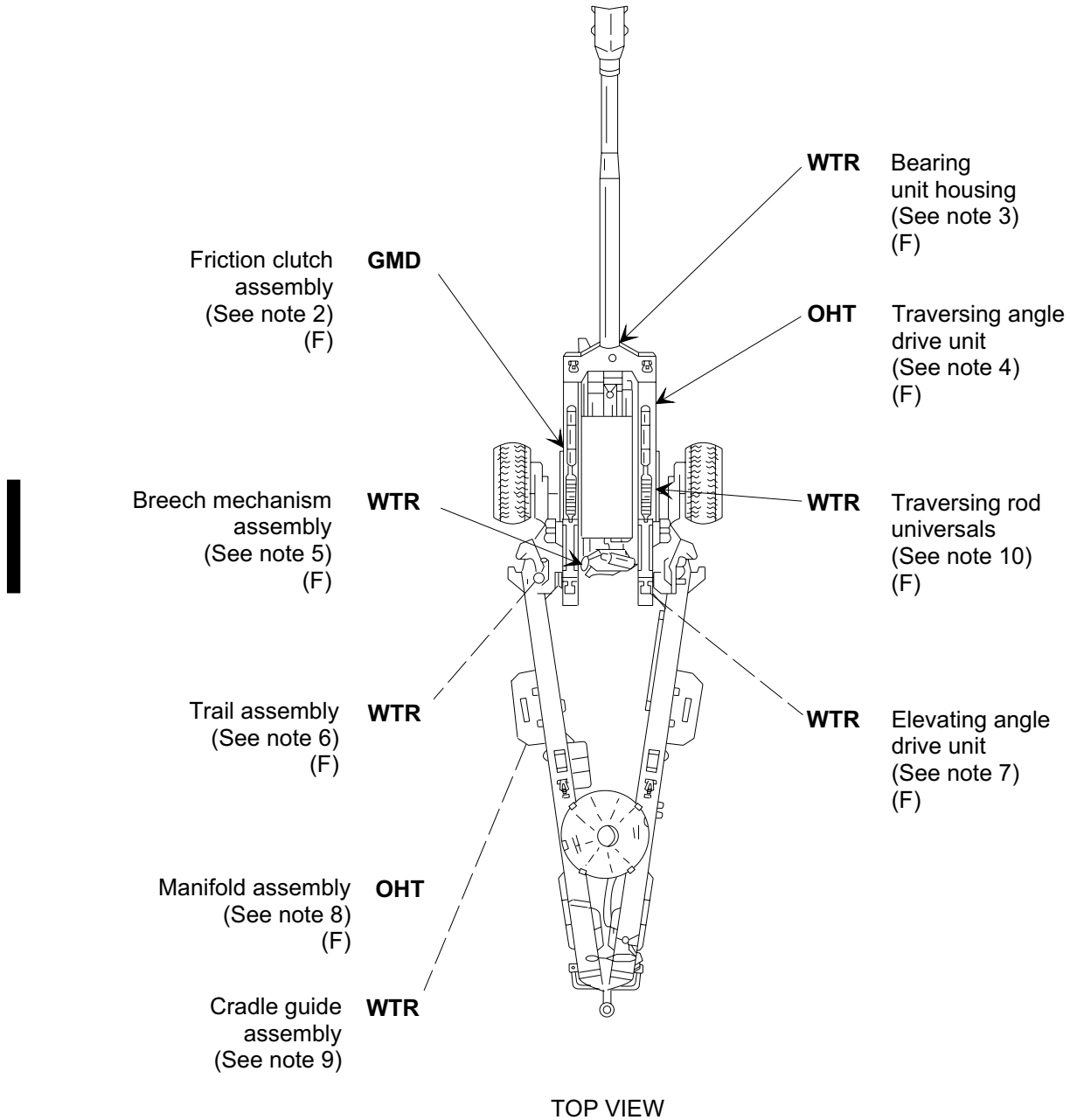

ANNUAL NOTES

NOTE 2

FRICITION CLUTCH ASSEMBLY (F)

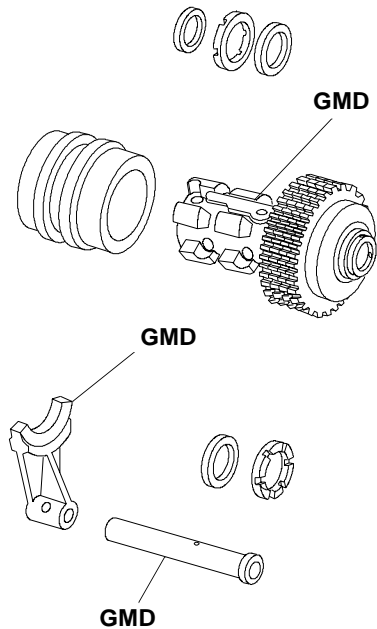

Lube with GMD.

NOTE 3

BEARING UNIT HOUSING (F)

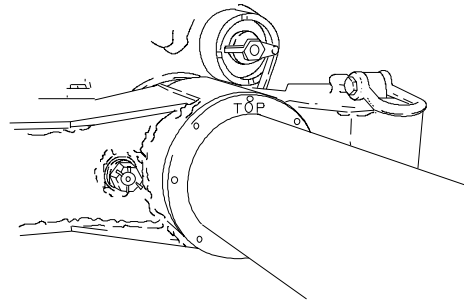

Remove, disassemble, clean, lube with WTR, and reassemble.

NOTE 4

TRAVERSING ANGLE DRIVE UNIT (F)

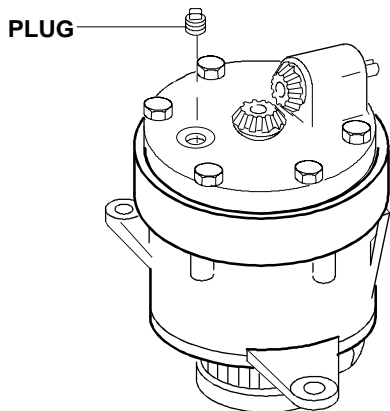

Remove PLUG and add 1/2 pint (237 ml) of OHT.

NOTE 5

BREECH MECHANISM ASSEMBLY (F)

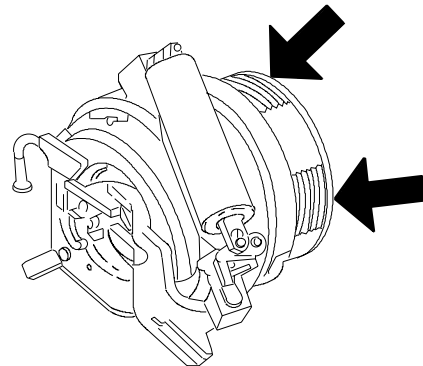

Remove breech mechanism and clean threads on cannon tube. Clean the outer and inner threads on the breech mechanism and rear yoke with WTR.

ANNUAL NOTES (cont)

NOTE 6

TRAIL ASSEMBLY (F)

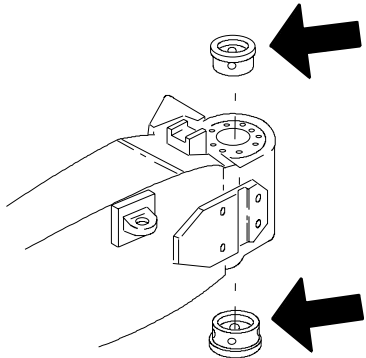

Remove trail. Clean the inside diameter of bushings including the grease grooves. Apply grease to grease fittings on trail and check that grease flows through the access holes to the inside diameter of the bushing. If grease does not flow freely, remove bushing and clean the groove on the outside diameter of bushing.

NOTE

Check grease flow from trail grease fitting to inside of trail, to ensure that grease fitting is not plugged.

Install bushing and reassemble trail to howitzer (both sides).

NOTE 8

MANIFOLD ASSEMBLY (F)

Drain OHT from reservoir, actuate selector valves and ram pumps to ensure all OHT is removed. Add uncontaminated OHT and purge the complete hydraulic system.

NOTE 7

ELEVATING ANGLE DRIVE UNIT (F)

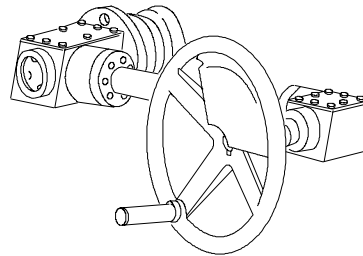

Remove, disassemble, clean, lube with WTR, and reassemble (both sides).

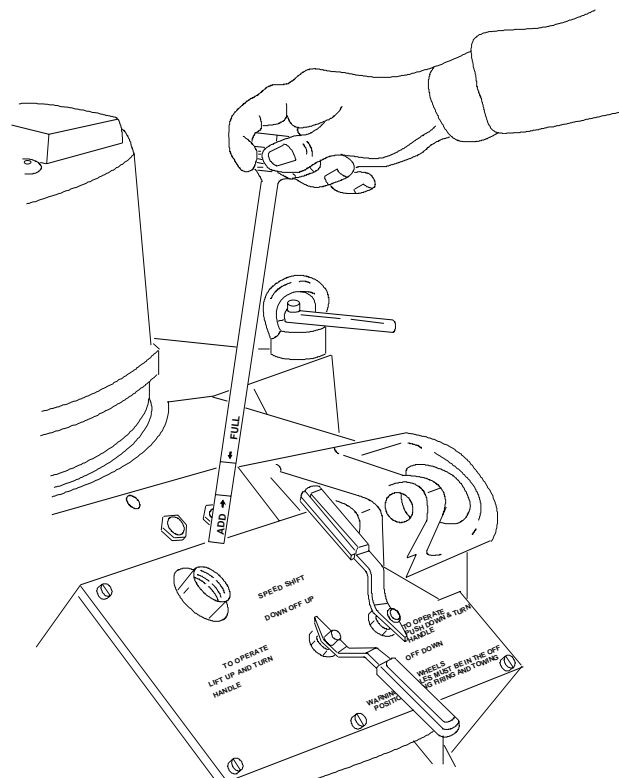

ANNUAL NOTES (cont)

NOTE 9

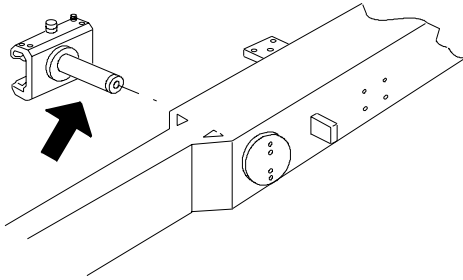

Remove cradle guide assembly. Clean, remove old grease, and relube with WTR.

NOTE 10

TRAVERSING ROD UNIVERSALS (F)
(Bellows removed for clarity; modified howitzers only)

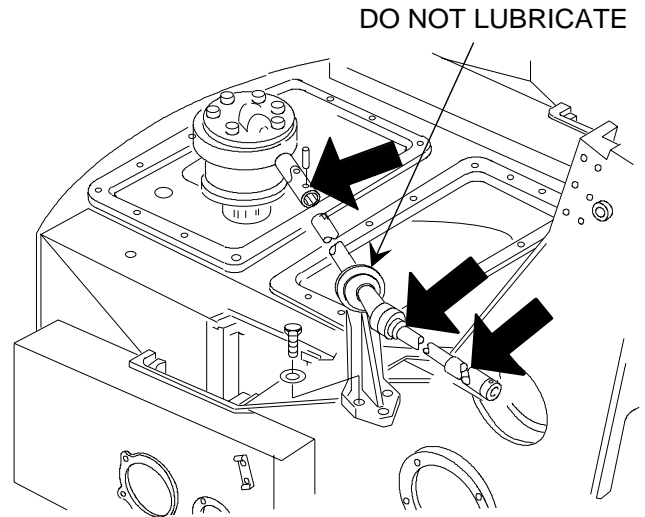

CAUTION

Do not lube torque limiter.

Move bellows to one side of universals if necessary to lube three universals with light coat of WTR.

BI-YEARLY

LUBRICANT

LUBRICANT

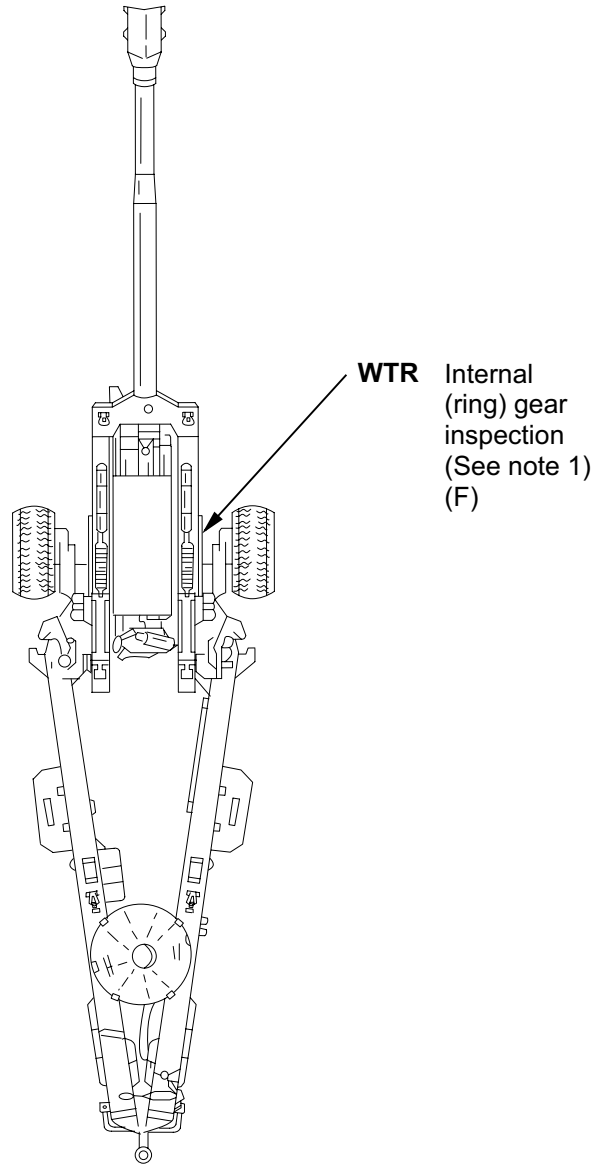

TOP VIEW

BI-YEARLY NOTES

NOTE 1

INTERNAL (RING) GEAR INSPECTION (F)

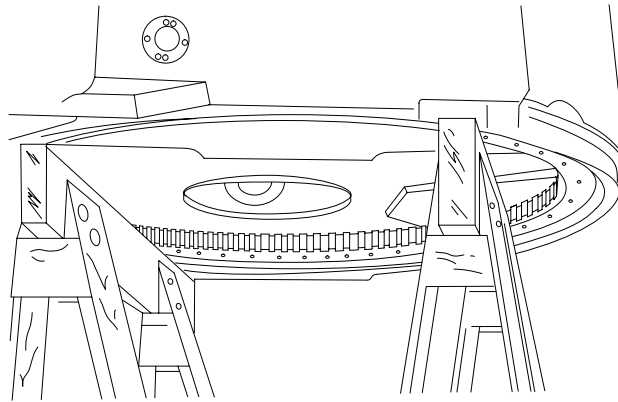

WARNING

Wear eye protection during cleaning procedures.

- a. Ensure necessary equipment conditions are met. Perform removal steps 1 through 8 of Paragraph 2-36.
- b. Clean all old grease from surface, teeth, and mounting bolt holes of the ring gear.

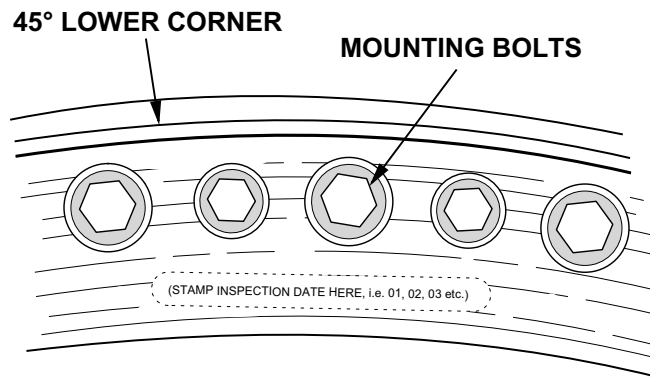

- c. Inspect ring gear for any cracks in outer diameter surface, especially the 45 degree lower corner surface. If any cracks are found, the ring gear is condemned. Replacement is required.

BI-YEARLY NOTES (cont)

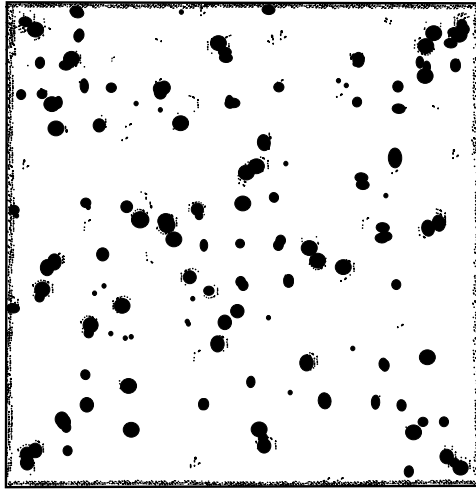

NOTE

Pitting beyond this amount condemns gear.

- d. Inspect ring gear surface for excessive pitting; see pitting comparison illustration. Excessive pitting that spreads over any 12 consecutive mounting bolt holes condemns the ring gear. Replacement is required.
- e. Clean mounting bolt holes using an air hose and nozzle.
- f. Remove ring gear mounting bolts and inspect for corrosion; replace with new bolts as required.
- g. Apply sealing compound (item 28.1, appx B) to all bolts and install.
- h. Torque bolts to 80 to 85 ft-lb (108 to 115 N-m).
- i. Apply WTR (item 11, appx B) to ring gear teeth only. DO NOT apply any lubricant to the ring gear surface or the bottom carriage mounting area for the ring gear.
- j. Upon completion of inspection, stamp the last two digits of the present year (i.e., 01, 02, etc.) on the bottom surface of the ring gear in a location near the front (muzzle end) of the top carriage. If there are dates of previous years already stamped on surface, stamp new numbers beside them. Use 3/8 in. (0.95 cm) stamps for this procedure.
- k. For reassembly, perform installation steps 8 through 14 of Paragraph 2-36.

ALPHABETICAL INDEX

Subject	Page
A	
Actuator cylinder assembly:	
Disassembly	2-301
Inspection/repair	2-301
Installation.....	2-303
Maintenance instructions.....	2-298
Reassembly.....	2-302
Removal	2-298
Adapter, adapter assembly, support stud, and pin assembly:	
Inspection/repair	3-5
Installation and shimming.....	3-5
Maintenance instructions.....	3-3
Removal	3-4
Air cylinder assembly:	
Inspection/repair	2-131
Installation.....	2-132
Maintenance instructions.....	2-129
Removal	2-129
Troubleshooting.....	2-12
Air pressure gage assembly:	
Disassembly	2-394
Inspection	2-393
Maintenance instructions.....	2-393
Reassembly.....	2-394
Repair	2-394
Troubleshooting.....	2-22
Air pressure tank:	
Inspection/repair	2-340
Installation.....	2-340
Maintenance instructions.....	2-339
Removal	2-339
Ammunition loading tray:	
Disassembly	2-391
Inspection/repair	2-391
Maintenance instructions.....	2-391
Reassembly.....	2-391
Troubleshooting.....	2-21
Arm and spindle assembly:	
Disassembly	2-326
Inspection/repair	2-327
Maintenance instructions.....	2-326
Reassembly.....	2-327

Subject	B	Page
Bearing unit housing:		
Disassembly		2-173
Inspection/repair		2-174
Installation.....		2-174
Maintenance instructions.....		2-172
Reassembly.....		2-174
Removal		2-172
Bottom carriage assembly:		
Disassembly		2-258
Inspection/repair		2-262
Maintenance instructions.....		2-258
Reassembly.....		2-263
Troubleshooting.....		2-17
Bottom carriage assembly—rear brake parts emergency relay valve:		
Inspection/repair		2-337
Installation.....		2-337
Maintenance instructions.....		2-335
Removal		2-335
Bottom carriage assembly—wheel and axle:		
Adjustment.....		2-325
Disassembly		2-321
Inspection/repair		2-322
Maintenance instructions.....		2-320
Reassembly.....		2-323
Bracket assembly:		
Disassembly		2-202
Inspection/repair		2-201
Installation.....		2-203
Maintenance instructions.....		2-201
Reassembly.....		2-203
Removal		2-201
Brake head assemblies:		
Disassembly		2-316
Inspection/repair		2-317
Maintenance instructions.....		2-314
Reassembly.....		2-317
Breach mechanism assembly:		
Disassembly		2-51
Inspection/repair		2-54
Installation.....		2-57
Maintenance instructions.....		2-49
Reassembly.....		2-54
Removal		2-49
Troubleshooting.....		2-6

Subject	Page
B (cont)	
Brake precheck, housing assembly, and filter assembly:	
Inspection/repair	2-331
Installation.....	2-332
Maintenance instructions.....	2-328
Removal	2-330
Breechblock assembly:	
Troubleshooting.....	2-6

C

Cannon tube:	
Inspection	2-43
Inspection/repair	2-46
Installation.....	2-46
Maintenance instructions.....	2-42
Removal	2-43
Troubleshooting.....	2-5
Common tools and equipment	2-1
Corrosion prevention and control (CPC)	1-4
Cradle assembly:	
Installation of clevis assembly and parts	2-165
Installation of holders and parts.....	2-166
Maintenance instructions.....	2-164
Removal of clevis assembly and parts	2-164
Removal of holders and parts.....	2-166
Replacement of holders and parts	2-167

D

Destruction of Army materiel to prevent enemy use	1-3
Detent assembly:	
Disassembly	2-305
Inspection/repair	2-306
Installation.....	2-306
Maintenance instructions.....	2-305
Reassembly.....	2-306
Removal	2-305
Direct support troubleshooting information	2-2

Subject	Page
E	
Elevating angle drive unit:	
Disassembly	2-183
Inspection/repair	2-185
Installation.....	2-190
Maintenance instructions.....	2-182
Reassembly.....	2-186
Removal	2-183
Service.....	2-190
Elevating handwheel:	
Installation.....	2-182
Maintenance instructions.....	2-181
Removal	2-181
Repair	2-181
Elevating mechanism:	
Troubleshooting.....	2-13
Elevating screw assembly:	
Elevation ball screw timing	2-200
Disassembly	2-196
Inspection/repair	2-196
Installation.....	2-196
Maintenance instructions.....	2-191
Reassembly.....	2-196
Removal	2-192
Equilibrator assembly:	
Disassembly	2-157
Inspection/repair	2-158
Installation.....	2-160
Maintenance instructions.....	2-151
Reassembly.....	2-159
Removal	2-156
Equipment characteristics, capabilities, and features	1-4
Equipment data	1-6
Expendable/durable supplies and materials list	B-1
F	
Friction clutch:	
Disassembly	2-206
Inspection/repair	2-209
Installation.....	2-214
Maintenance instructions.....	2-204
Reassembly.....	2-209
Removal	2-204
Service.....	2-216

Subject	Page
F (cont)	
Front yoke:	
Disassembly	2-136
Inspection/repair	2-136
Maintenance instructions	2-136
Reassembly	2-136
Troubleshooting	2-13
G	
General maintenance instructions	2-23
General support troubleshooting information	3-1
Guide assembly:	
Disassembly	2-179
Inspection/repair	2-179
Installation	2-180
Maintenance instructions	2-178
Reassembly	2-179
Removal	2-178
Gun tube travel lock:	
Disassembly	2-355
Inspection/repair	2-355
Installation	2-356.1
Maintenance instructions	2-354
Reassembly	2-356
Removal	2-354
H	
Hinge pin puller assembly:	
Inspection/repair	2-394
Maintenance instructions	2-394
How to use this manual	iii
HyPAK solenoid:	
Disassembly	2-264.2
Inspection/repair	2-264.6
Reassembly	2-264.6
HyPAK system:	
Troubleshooting	2-16.1
I	
Illustrated list of manufactured items	C-1
Internal gear:	
Inspection	E-9

Subject	Page
L	
Left clevis assembly:	
Disassembly	2-360
Inspection/repair	2-359
Installation	2-360
Maintenance instructions	2-359
Reassembly	2-360
Removal	2-359
Left trail assembly:	
Disassembly	2-364
Inspection/repair	2-364
Installation	2-365
Maintenance instructions	2-362
Reassembly	2-365
Removal	2-363
Location and description of major components	1-4
Lock assembly:	
Disassembly	2-257
Inspection/repair	2-257
Maintenance instructions	2-257
Reassembly	2-257
Locking assembly:	
Disassembly	2-307
Inspection/repair	2-307
Maintenance instructions	2-307
Reassembly	2-308
Lubrication instructions	E-1
M	
Maintenance forms, records, and reports	1-3
Manifold assembly and hydraulic parts:	
Disassembly	2-276
Inspection/repair	2-279
Installation	2-282
Maintenance instructions	2-271
Reassembly	2-279
Removal	2-272
Service	2-289
Middle yoke:	
Disassembly	2-136.1
Inspection/repair	2-136.1
Maintenance instructions	2-136.1
Reassembly	2-136.1

Subject	Page
M (cont)	
Modification and system improvement package	1-5
M39 carriage miscellaneous parts:	
Disassembly	2-139
Inspection/repair	2-140
Maintenance instructions	2-139
Reassembly	2-140
M39 carriage variable recoil parts:	
Adjustment.....	2-149
Disassembly	2-142
Inspection/repair	2-145
Maintenance instructions	2-141
Reassembly.....	2-145
M45 recoil mechanism:	
Adjustment.....	2-86
Alternate method - filling with oil and purging oil of air	2-80
Charging recoil mechanism with nitrogen pressure when air cylinder assembly, recuperator cylinder assembly, or replenisher cylinder assembly are replaced	2-65
Draining oil reserves	2-80.12
Filling with oil and purging oil of air	2-71
Inspection/repair	2-83
Installation.....	2-84
Leak detection	2.80.8
Lowering nitrogen pressure	2-60
Maintenance instructions	2-58
Removal	2-81
Troubleshooting.....	2-7
M45 recoil mechanism exerciser:	
Disassembly	2-396.5
Exercise instructions.....	2-136.2
Inspection	2-396
Installation/operation.....	2-136.2
Maintenance instructions	2-396
Reassembly	2-396.7
Removal	2-136.9
M198 howitzer:	
Boresighting.....	2-400
Leveling the M199 cannon tube.....	2-400
Leveling the trunnions.....	2-397
Maintenance instructions.....	2-396.10
Synchronization	2-404
M199 cannon:	
Inspection/repair	2-29
Installation.....	2-29
Maintenance instructions	2-23
Removal	2-24.1
Service.....	2-29

Subject	Page
N	
Nitrogen charging assembly:	
Disassembly	2-392
Inspection	2-392
Maintenance instructions	2-392
Reassembly	2-393
Repair	2-392
Troubleshooting	2-21
Nitrogen charging kit:	
Troubleshooting	2-21
Nitrogen hose assembly:	
Disassembly	2-388
Inspection/repair	2-388
Maintenance instructions	2-387
Reassembly	2-388
Testing	2-389
Troubleshooting	2-21
O	
Official nomenclature, names, and designations	1-3
Oil valve assembly:	
Inspection/repair	2-135
Installation	2-135
Maintenance instructions	2-134
Removal	2-134
P	
Power booster assembly:	
Disassembly	2-342
Inspection/repair	2-344
Installation	2-346
Maintenance instructions	2-341
Reassembly	2-344
Removal	2-341
Service	2-346.1
Pre-embarkation inspection	2-406
Preparation for storage and shipment	1-3, 2-67
Principles of operation	1-9

Subject	Page
R	
Ram hydraulic pumps:	
Disassembly	2-268
Inspection/repair	2-269
Maintenance instructions	2-266
Reassembly	2-269
Recoil cylinder assemblies:	
Disassembly	2-104
Inspection/repair	2-105
Installation.....	2-107
Maintenance instructions	2-100
Reassembly.....	2-105
Removal	2-101
Troubleshooting.....	2-11
Recoil mechanism:	
Troubleshooting.....	2-7
Recuperator cylinder assembly and parts:	
Disassembly	2-120
Inspection/repair	2-120
Installation.....	2-121
Maintenance instructions	2-111
Reassembly.....	2-121
Removal	2-112
Troubleshooting.....	2-12
References.....	A-1
Repair parts.....	2-1
Replenisher cylinder assembly:	
Inspection/repair	2-91
Installation.....	2-92
Maintenance instructions	2-88.6
Removal	2-88.6
Troubleshooting.....	2-11
Reporting equipment improvement recommendations (EIR's)	1-3
Rest assembly:	
Disassembly	2-176
Inspection/repair	2-177
Installation.....	2-177
Maintenance instructions	2-175
Reassembly.....	2-177
Removal	2-175
Right and left manual brake assembly:	
Disassembly	2-310
Inspection/repair	2-310
Maintenance instructions	2-308
Reassembly.....	2-312

Subject	Page
R (cont)	
Right clevis assembly:	
Disassembly	2-368
Inspection/repair	2-367
Installation.....	2-368
Maintenance instructions.....	2-366
Reassembly.....	2-368
Removal	2-367
Right trail assembly and trail locking handle assembly:	
Disassembly	2-377
Inspection/repair	2-378
Installation.....	2-379
Maintenance instructions.....	2-370
Reassembly.....	2-378
Removal	2-371
Service.....	2-386
S	
Scope	1-3
Safety strut assembly:	
Disassembly	2-395
Inspection/repair	2-395
Maintenance instructions.....	2-395
Reassembly.....	2-396
Sleeve bearing assembly:	
Disassembly	2-97
Inspection/repair	2-97
Installation.....	2-97
Maintenance instructions.....	2-95
Reassembly.....	2-97
Removal	2-95
Special tools, TMDE, and support equipment.....	2-1
Speed shift cylinder assembly:	
Disassembly	2-293
Inspection/repair	2-293
Installation.....	2-294
Maintenance instructions.....	2-290
Reassembly.....	2-294
Removal	2-290
T	
Table of contents.....	i

Subject	Page
T (cont)	
Thermal warning device:	
Calibration.....	2-40
Disassembly	2-36
Inspection/repair	2-38
Installation.....	2-40
Maintenance instructions.....	2-35
Reassembly.....	2-38
Removal	2-35
Troubleshooting.....	2-4
Top carriage assembly:	
Disassembly	2-245
Inspection/repair	2-250
Installation.....	2-254
Maintenance instructions.....	2-242
Reassembly.....	2-250
Removal	2-243
Troubleshooting.....	2-16.1
Torque limits.....	D-1
Travel lock assembly:	
Disassembly	2-150
Inspection/repair	2-150
Maintenance instructions.....	2-150
Reassembly.....	2-150
Traverse stop:	
Disassembly	2-358
Inspection/repair	2-358
Installation.....	2-358
Maintenance instructions.....	2-357
Reassembly.....	2-358
Removal	2-358
Traversing angle drive unit:	
Adjustment.....	2-240
Disassembly	2-233
Inspection/repair	2-236
Installation.....	2-238
Maintenance instructions.....	2-232
Reassembly.....	2-236
Removal	2-232
Service.....	2-241
Traversing drive unit:	
Disassembly	2-223
Inspection/repair	2-225
Installation.....	2-227
Maintenance instructions.....	2-222
Reassembly.....	2-225
Removal	2-222

Subject	Page
T (cont)	
Traversing handwheel:	
Installation.....	2-221
Maintenance instructions.....	2-221
Removal	2-221
Traversing mechanism:	
Troubleshooting.....	2-16
Traversing shaft assembly:	
Adjustment.....	2-229
Disassembly	2-229
Inspection/repair	2-230
Installation.....	2-230
Maintenance instructions.....	2-227
Reassembly.....	2-230
Removal	2-228
Troubleshooting information, direct support.....	2-2
Troubleshooting information, general support	3-1

W

Warnings.....	a
Wheel and axle (See Bottom carriage assembly-wheel and axle parts)	

By Order of the Secretary of the Army:

CARL E. VUONO
General, United States Army
Chief of Staff

Official:

PATRICIA P. HICKERSON
Colonel, United States Army
The Adjutant General

DISTRIBUTION: To be distributed in accordance with DA Form 12-40E, Block 0549,
Direct and General Support Maintenance Requirements for TM 9-1025-211-34.

RECOMMENDED CHANGES TO PUBLICATIONS AND BLANK FORMS For use of this form, see AR 25-30; the proponent agency is ODISC4.	Use Part II (<i>reverse</i>) for Repair Parts and Special Tool Lists (RPSTL) and Supply Catalogs/Supply Manuals (SC/SM).	DATE Date you filled out this form.
---	--	--

TO: (<i>Forward to proponent of publication or form</i>) (<i>Include ZIP Code</i>) AMSTA-LC-CI / TECH PUBS, TACOM-RI 1 Rock Island Arsenal Rock Island, IL 61299-7630	FROM: (<i>Activity and location</i>) (<i>Include ZIP Code</i>) Your mailing address
---	---

PART I - ALL PUBLICATIONS (EXCEPT RPSTL AND SC/SM) AND BLANK FORMS

PUBLICATION/FORM NUMBER TM 9-1025-211-34	DATE 23 May 91	TITLE DS and GS Maint Manual for Howitzer, Medium, Towed: 155-mm, M198
---	-------------------	---

ITEM NO.	PAGE NO.	PARA-GRAPH	LINE NO. *	FIGURE NO.	TABLE NO.	RECOMMENDED CHANGES AND REASON <i>(Provide exact wording of recommended changes, if possible).</i>
	2-396	2-65.1				Nomenclature for the recoil exerciser is incorrect. It should be called RE 198 Recoil Exerciser.

SAMPLE

**Reference to line numbers within the paragraph or subparagraph.*

TYPED NAME, GRADE OR TITLE Your Name	TELEPHONE EXCHANGE/AUTOVON, PLUS EXTENSION	SIGNATURE Your Signature
---	--	---------------------------------

TO: <i>(Forward direct to addressee listed in publication)</i> AMSTA-LC-CI / TECH PUBS, TACOM-RI 1 Rock Island Arsenal Rock Island, IL 61299-7630	FROM: <i>(Activity and location) (Include ZIP Code)</i> Your address	DATE Date you filled out this form
---	--	--

PART II – REPAIR PARTS AND SPECIAL TOOL LISTS AND SUPPLY CATALOGS/SUPPLY MANUALS

PUBLICATION NUMBER TM 9-1025-211-34	DATE 23 May 91	TITLE DS and GS Maint Manual for Howitzer, Medium, Towed: 155-mm, M198
--	-------------------	--

PAGE NO.	COLM NO.	LINE NO.	NATIONAL STOCK NUMBER	REFERENCE NO.	FIGURE NO.	ITEM NO.	TOTAL NO. OF MAJOR ITEMS SUPPORTED	RECOMMENDED ACTION

PART III – REMARKS *(Any general remarks or recommendations, or suggestions for improvement of publications and blank forms. Additional blank sheets may be used if more space is needed.)*

TYPED NAME, GRADE OR TITLE Your Name	TELEPHONE EXCHANGE/AUTOVON, PLUS EXTENSION	SIGNATURE Your Signature
---	--	-----------------------------

RECOMMENDED CHANGES TO PUBLICATIONS AND BLANK FORMS For use of this form, see AR 25-30; the proponent agency is ODISC4.	Use Part II (<i>reverse</i>) for Repair Parts and Special Tool Lists (RPSTL) and Supply Catalogs/Supply Manuals (SC/SM).	DATE
---	--	------

TO: (<i>Forward to proponent of publication or form</i>) (<i>Include ZIP Code</i>) AMSTA-LC-CI / TECH PUBS, TACOM-RI 1 Rock Island Arsenal Rock Island, IL 61299-7630	FROM: (<i>Activity and location</i>) (<i>Include ZIP Code</i>)
---	---

PART I – ALL PUBLICATIONS (EXCEPT RPSTL AND SC/SM) AND BLANK FORMS

PUBLICATION/FORM NUMBER TM 9-1025-211-34	DATE 23 May 91	TITLE DS and GS Maint Manual for Howitzer, Medium, Towed: 155-mm, M198
---	-------------------	--

ITEM NO.	PAGE NO.	PARA-GRAPH	LINE NO. *	FIGURE NO.	TABLE NO.	RECOMMENDED CHANGES AND REASON <i>(Provide exact wording of recommended changes, if possible).</i>

**Reference to line numbers within the paragraph or subparagraph.*

TYPED NAME, GRADE OR TITLE	TELEPHONE EXCHANGE/AUTOVON, PLUS EXTENSION	SIGNATURE
----------------------------	--	-----------

TO: <i>(Forward direct to addressee listed in publication)</i> AMSTA-LC-CI / TECH PUBS, TACOM-RI 1 Rock Island Arsenal Rock Island, IL 61299-7630	FROM: <i>(Activity and location) (Include ZIP Code)</i>	DATE
---	--	-------------

PART II – REPAIR PARTS AND SPECIAL TOOL LISTS AND SUPPLY CATALOGS/SUPPLY MANUALS

PUBLICATION NUMBER TM 9-1025-211-34	DATE 23 May 91	TITLE DS and GS Maint Manual for Howitzer, Medium, Towed: 155-mm, M198
---	--------------------------	---

PAGE NO.	COLM NO.	LINE NO.	NATIONAL STOCK NUMBER	REFERENCE NO.	FIGURE NO.	ITEM NO.	TOTAL NO. OF MAJOR ITEMS SUPPORTED	RECOMMENDED ACTION

PART III – REMARKS *(Any general remarks or recommendations, or suggestions for improvement of publications and blank forms. Additional blank sheets may be used if more space is needed.)*

TYPED NAME, GRADE OR TITLE	TELEPHONE EXCHANGE/AUTOVON, PLUS EXTENSION	SIGNATURE
----------------------------	--	-----------

RECOMMENDED CHANGES TO PUBLICATIONS AND BLANK FORMS For use of this form, see AR 25-30; the proponent agency is ODISC4.	Use Part II (reverse) for Repair Parts and Special Tool Lists (RPSTL) and Supply Catalogs/Supply Manuals (SC/SM).	DATE
---	---	------

TO: (Forward to proponent of publication or form) (Include ZIP Code) AMSTA-LC-CI / TECH PUBS, TACOM-RI 1 Rock Island Arsenal Rock Island, IL 61299-7630	FROM: (Activity and location) (Include ZIP Code)
---	---

PART I – ALL PUBLICATIONS (EXCEPT RPSTL AND SC/SM) AND BLANK FORMS

PUBLICATION/FORM NUMBER TM 9-1025-211-34	DATE 23 May 91	TITLE DS and GS Maint Manual for Howitzer, Medium, Towed: 155-mm, M198
---	-------------------	--

ITEM NO.	PAGE NO.	PARA-GRAPH	LINE NO. *	FIGURE NO.	TABLE NO.	RECOMMENDED CHANGES AND REASON <i>(Provide exact wording of recommended changes, if possible).</i>

**Reference to line numbers within the paragraph or subparagraph.*

TYPED NAME, GRADE OR TITLE	TELEPHONE EXCHANGE/AUTOVON, PLUS EXTENSION	SIGNATURE
----------------------------	--	-----------

TO: <i>(Forward direct to addressee listed in publication)</i> AMSTA-LC-CI / TECH PUBS, TACOM-RI 1 Rock Island Arsenal Rock Island, IL 61299-7630	FROM: <i>(Activity and location) (Include ZIP Code)</i>	DATE
---	--	-------------

PART II – REPAIR PARTS AND SPECIAL TOOL LISTS AND SUPPLY CATALOGS/SUPPLY MANUALS

PUBLICATION NUMBER TM 9-1025-211-34	DATE 23 May 91	TITLE DS and GS Maint Manual for Howitzer, Medium, Towed: 155-mm, M198
--	-------------------	--

PAGE NO.	COLM NO.	LINE NO.	NATIONAL STOCK NUMBER	REFERENCE NO.	FIGURE NO.	ITEM NO.	TOTAL NO. OF MAJOR ITEMS SUPPORTED	RECOMMENDED ACTION

PART III – REMARKS *(Any general remarks or recommendations, or suggestions for improvement of publications and blank forms. Additional blank sheets may be used if more space is needed.)*

TYPED NAME, GRADE OR TITLE	TELEPHONE EXCHANGE/AUTOVON, PLUS EXTENSION	SIGNATURE
----------------------------	--	-----------

RECOMMENDED CHANGES TO PUBLICATIONS AND BLANK FORMS For use of this form, see AR 25-30; the proponent agency is ODISC4.	Use Part II (<i>reverse</i>) for Repair Parts and Special Tool Lists (RPSTL) and Supply Catalogs/Supply Manuals (SC/SM).	DATE
---	--	------

TO: (<i>Forward to proponent of publication or form</i>) (<i>Include ZIP Code</i>) AMSTA-LC-CI / TECH PUBS, TACOM-RI 1 Rock Island Arsenal Rock Island, IL 61299-7630	FROM: (<i>Activity and location</i>) (<i>Include ZIP Code</i>)
---	---

PART I – ALL PUBLICATIONS (EXCEPT RPSTL AND SC/SM) AND BLANK FORMS

PUBLICATION/FORM NUMBER TM 9-1025-211-34	DATE 23 May 91	TITLE DS and GS Maint Manual for Howitzer, Medium, Towed: 155-mm, M198
---	-------------------	--

ITEM NO.	PAGE NO.	PARA-GRAPH	LINE NO. *	FIGURE NO.	TABLE NO.	RECOMMENDED CHANGES AND REASON <i>(Provide exact wording of recommended changes, if possible).</i>

**Reference to line numbers within the paragraph or subparagraph.*

TYPED NAME, GRADE OR TITLE	TELEPHONE EXCHANGE/AUTOVON, PLUS EXTENSION	SIGNATURE
----------------------------	--	-----------

TO: <i>(Forward direct to addressee listed in publication)</i> AMSTA-LC-CI / TECH PUBS, TACOM-RI 1 Rock Island Arsenal Rock Island, IL 61299-7630	FROM: <i>(Activity and location) (Include ZIP Code)</i>	DATE
---	--	-------------

PART II – REPAIR PARTS AND SPECIAL TOOL LISTS AND SUPPLY CATALOGS/SUPPLY MANUALS

PUBLICATION NUMBER TM 9-1025-211-34	DATE 23 May 91	TITLE DS and GS Maint Manual for Howitzer, Medium, Towed: 155-mm, M198
--	-------------------	--

PAGE NO.	COLM NO.	LINE NO.	NATIONAL STOCK NUMBER	REFERENCE NO.	FIGURE NO.	ITEM NO.	TOTAL NO. OF MAJOR ITEMS SUPPORTED	RECOMMENDED ACTION

PART III – REMARKS *(Any general remarks or recommendations, or suggestions for improvement of publications and blank forms. Additional blank sheets may be used if more space is needed.)*

TYPED NAME, GRADE OR TITLE	TELEPHONE EXCHANGE/AUTOVON, PLUS EXTENSION	SIGNATURE
----------------------------	--	-----------

METRIC CHART

THE METRIC SYSTEM AND EQUIVALENTS

LINEAR MEASURE

1 Centimeter = 10 Millimeters = 0.01 Meters = 0.3937 Inches
 1 Meter = 100 Centimeters = 1000 Millimeters = 39.37 Inches
 1 Kilometer = 1000 Meters = 0.621 Miles

WEIGHTS

1 Gram = 0.001 Kilograms = 1000 Milligrams = 0.035 Ounces
 1 Kilogram = 1000 Grams = 2.2 Lb
 1 Metric Ton = 1000 Kilograms = 1 Megagram = 1.1 Short Tons

LIQUID MEASURE

1 Milliliter = 0.001 Liters = 0.0338 Fluid Ounces
 1 Liter = 1000 Milliliters = 33.82 Fluid Ounces

SQUARE MEASURE

1 Sq Centimeter = 100 Sq Millimeters = 0.155 Sq Inches
 1 Sq Meter = 10,000 Sq Centimeters = 10.76 Sq Feet
 1 Sq Kilometer = 1,000,000 Sq Meters = 0.386 Sq Miles

CUBIC MEASURE

1 Cu Centimeter = 1000 Cu Millimeters = 0.06 Cu Inches
 1 Cu Meter = 1,000,000 Cu Centimeters = 35.31 Cu Feet

TEMPERATURE

$5/9 (^{\circ}\text{F} - 32) = ^{\circ}\text{C}$
 212° Fahrenheit is equivalent to 100° Celsius
 90° Fahrenheit is equivalent to 32.2° Celsius
 32° Fahrenheit is equivalent to 0° Celsius
 $9/5 \text{ C}^{\circ} + 32 = \text{F}^{\circ}$

APPROXIMATE CONVERSION FACTORS

TO CHANGE	TO	MULTIPLY BY
Inches	Centimeters	2.540
Feet	Meters	0.305
Yards	Meters	0.914
Miles	Kilometers	1.609
Square Inches	Square Centimeters	6.451
Square Feet	Square Meters	0.093
Square Yards	Square Meters	0.836
Square Miles	Square Kilometers	2.590
Acres	Square Hectometers	0.405
Cubic Feet	Cubic Meters	0.028
Cubic Yards	Cubic Meters	0.765
Fluid Ounces	Milliliters	29.573
Pints	Liters	0.473
Quarts	Liters	0.946
Gallons	Liters	3.785
Ounces	Grams	28.349
Pounds	Kilograms	0.454
Short Tons	Metric Tons	0.907
Pound-Feet	Newton-Meters	1.356
Pounds per Square Inch	Kilopascals	6.895
Miles per Gallon	Kilometers per Liter	0.425
Miles per Hour	Kilometers per Hour	1.609

TO CHANGE	TO	MULTIPLY BY
Centimeters	Inches	0.394
Meters	Feet	3.280
Meters	Yards	1.094
Kilometers	Miles	0.621
Square Centimeters	Square Inches	0.155
Square Meters	Square Feet	10.764
Square Meters	Square Yards	1.196
Square Kilometers	Square Miles	0.386
Square Hectometers	Acres	2.471
Cubic Meters	Cubic Feet	35.315
Cubic Meters	Cubic Yards	1.308
Milliliters	Fluid Ounces	0.034
Liters	Pints	2.113
Liters	Quarts	1.057
Liters	Gallons	0.264
Grams	Ounces	0.035
Kilograms	Pounds	2.205
Metric Tons	Short Tons	1.102
Newton Meters	Pound Feet	0.738
Kilopascals	Pounds per Square Inch	0.145
Kilometers per Liter	Miles per Gallon	2.354
Kilometers per Hour	Miles per Hour	0.621

